

# **S3C24A0A**

**32-BIT RISC  
MICROPROCESSOR  
USER'S MANUAL**

**Revision 0.4  
(Preliminary)**



**ELECTRONICS**

# Important Notice

The information in this publication has been carefully checked and is believed to be entirely accurate at the time of publication. Samsung assumes no responsibility, however, for possible errors or omissions, or for any consequences resulting from the use of the information contained herein.

Samsung reserves the right to make changes in its products or product specifications with the intent to improve function or design at any time and without notice and is not required to update this documentation to reflect such changes.

This publication does not convey to a purchaser of semiconductor devices described herein any license under the patent rights of Samsung or others.

Samsung makes no warranty, representation, or guarantee regarding the suitability of its products for any particular purpose, nor does Samsung assume any liability arising out of the application or use of any product or circuit and specifically disclaims any and all liability, including without limitation any consequential or incidental damages.

**S3C24A0A 32-Bit RISC Microprocessor  
User's Manual, Revision 0.4  
Publication Number: 20-S3-CS3C24A0A-112004**

© 2004 Samsung Electronics

All rights reserved. No part of this publication may be reproduced, stored in a retrieval system, or transmitted in any form or by any means, electric or mechanical, by photocopying, recording, or otherwise, without the prior written consent of Samsung Electronics.

*Samsung Electronics' microcontroller business has been awarded full ISO-14001 certification (BVQ1 Certificate No. 9330). All semiconductor products are designed and manufactured in accordance with the highest quality standards and objectives.*

Samsung Electronics Co., Ltd.  
San #24 Nongseo-Ri, Giheung- Eup  
Yongin-City, Gyeonggi-Do, Korea  
C.P.O. Box #37, Suwon 449-900

TEL: (82)-(031)-209-1490  
FAX: (82) (331) 209-1909  
Home-Page URL: [Http://www.samsungsemi.com/](http://www.samsungsemi.com/)

Printed in the Republic of Korea

"Typical" parameters can and do vary in different applications. All operating parameters, including "Typicals" must be validated for each customer application by the customer's technical experts.

Samsung products are not designed, intended, or authorized for use as components in systems intended for surgical implant into the body, for other applications intended to support or sustain life, or for any other application in which the failure of the Samsung product could create a situation where personal injury or death may occur.

Should the Buyer purchase or use a Samsung product for any such unintended or unauthorized application, the Buyer shall indemnify and hold Samsung and its officers, employees, subsidiaries, affiliates, and distributors harmless against all claims, costs, damages, expenses, and reasonable attorney fees arising out of, either directly or indirectly, any claim of personal injury or death that may be associated with such unintended or unauthorized use, even if such claim alleges that Samsung was negligent regarding the design or manufacture of said product.

# Table of Contents

## Chapter 1 Product Overview

Architectural Overview .....	1-1
Features .....	1-2
Microprocessor and Overall Architecture .....	1-2
Memory Subsystem .....	1-2
General Peripherals .....	1-3
Serial Communication .....	1-3
Parallel Communication .....	1-4
Image and Video Processing .....	1-4
Display Control .....	1-6
Input Devices .....	1-6
Storage Devices .....	1-7
System Management .....	1-7
Electrical Characteristics .....	1-7
Package .....	1-7
Pin Assignment .....	1-9
Pin Descriptions .....	1-30
I/O Signal Descriptions .....	1-30
Address MAP .....	1-38
Address Space Assignment Overview .....	1-38
Device Specific Address Space .....	1-39
Internal Registers .....	1-42
Important Notes About S3C24A0A Special Registers .....	1-62

## Chapter 2 SRAM Controller

Overview .....	2-1
Feature .....	2-2
Block Diagram .....	2-2
Function Description .....	2-3
Programmable Access Cycle Write to Read Waveform .....	2-5
Special Function Registers .....	2-6
Srom Bus Width & Wait Contrl Register(SROM_BW) .....	2-6
Srom Bank Control Register (SROM_BC: XrCSn0 ~ XrCSn2) .....	2-7

## Table of Contents (Continued)

### Chapter 3 SDRAM Controller

Overview .....	3-1
Selection of SDRAM .....	3-2
Selection of SDRAM .....	3-2
SELF Refresh .....	3-2
SDRAM Initialization Sequence .....	3-3
SDRAM Configuration Register .....	3-6
SDRAM Control Register .....	3-7
Refresh Control Register .....	3-8

### Chapter 4 NAND Flash Controller

Overview .....	4-1
Features .....	4-1
Pin Configuration .....	4-2
Block Diagram .....	4-3
Boot Loader Function .....	4-4
Auto Load Mode .....	4-6
Auto Load Programming Guide .....	4-6
Auto Store Mode .....	4-7
Auto Store Programming Guide .....	4-7
Software Mode .....	4-8
Stepping Stone (4K-Byte SRAM) .....	4-9
Error Correction Code .....	4-9
ECC Module Features .....	4-10
ECC Programming Guide .....	4-10
NAND Flash Memory Configurations .....	4-11
NAND Flash Controller Special Registers .....	4-13
Configuration Register .....	4-13
Control Register .....	4-14
Command Register .....	4-15
Address Register .....	4-15
Main Data Area ECC0 Register .....	4-16
Main Data Area ECC1 Register .....	4-16
Main Data Area ECC2 Register .....	4-16
Main Data Area ECC3 Register .....	4-17
Spare Area ECC0 Register .....	4-17
Spare Area ECC1 Register .....	4-17
Control Status Register .....	4-18
ECC0 Status Register .....	4-19
ECC1 Status Register .....	4-19
Main Data Area ECC0 Status Register .....	4-20
Main Data Area ECC1 Status Register .....	4-20
Spare Area ECC Status Register .....	4-20
Start Block Address Register .....	4-21
END Block Address Register .....	4-21

## Table of Contents (Continued)

### Chapter 5 Bus Matrix

Overview.....	5-1
Special Function Registers .....	5-2
SROMC/NFLASHC Arbiter Priority Register (Priority 0) .....	5-2
SDRAMC Arbiter Priority Register (Priority 1) .....	5-2

### Chapter 6 Interrupt Controller

Overview.....	6-1
Functional Description.....	6-2
F-Bit and I-Bit Of PSR (Program Status Register) .....	6-2
Interrupt Mode .....	6-2
Interrupt Pending Register.....	6-2
Interrupt Mask Register .....	6-2
Interrupt Sources .....	6-3
Interrupt Priority Generating Block .....	6-4
Vectored Interrupt Mode (Only for IRQ) .....	6-5
Source Pending Register (SRCPND).....	6-7
Interrupt Mode Register (INTMOD) .....	6-9
Interrupt Mask Register (INTMSK) .....	6-11
Priority Register (PRIORITY).....	6-13
Interrupt Pending Register (INTIPND).....	6-14
Interrupt Offset Register (INTOFFSET).....	6-16
Sub Source Pending Register (SUBSRCPND).....	6-17
Interrupt Sub Mask Register (INTSUBMSK) .....	6-18
Vectored Interrupt Mode Register (VECT_INT_MODE) .....	6-19
Vector Address Register (VAR).....	6-19

## Table of Contents (Continued)

### Chapter 7 PWM Timer

Overview .....	7-1
Feature .....	7-1
PWM Timer Operation .....	7-3
Prescaler & Divider .....	7-3
Basic Timer Operation .....	7-3
Auto-Reload & Double Buffering .....	7-4
TIMER Initialization Using Manual Update Bit and Inverter Bit .....	7-4
Example of a Timer Operation .....	7-5
PWM (Pulse Width Modulation) .....	7-6
Output Level Control .....	7-7
DEAD Zone Generator .....	7-8
DMA Request Mode .....	7-9
PWM Timer Control Registers .....	7-10
Timer Configuration Register 0 (TCFG0) .....	7-10
Timer Configuration Register 1 (TCFG1) .....	7-11
Timer Control Register (TCON) .....	7-12
Timer 0 Count Observation Register (TCNTO0) .....	7-13
Timer 1 Count Buffer Register & Compare Buffer Register (TCNTB1, TCMPB1) .....	7-14
Timer 1 Count Observation Register (TCNTO1) .....	7-14
Timer 2 Count Buffer Register & Compare Buffer Register (TCNTB2, TCMPB2) .....	7-15
Timer 2 Count Observation Register (TCNTO2) .....	7-15
Timer 3 Count Buffer Register & Compare Buffer Register (TCNTB3, TCMPB3) .....	7-16
Timer 3 Count Observation Register (TCNTO3) .....	7-16
Timer 4 Count Buffer Register (TCNTB4) .....	7-17
Timer 4 Count Observation Register (TCNTO4) .....	7-17

### Chapter 8 Watchdog Timer

Overview .....	8-1
Features .....	8-1
Watchdog Timer Operation .....	8-2
WTDAT & WTCNT .....	8-2
Consideration of Debugging Environment .....	8-2
Watchdog Timer Special Registers .....	8-3
Watchdog Timer Control Register (WTCN) .....	8-3
Watchdog Timer Data Register (WTDAT) .....	8-4
Watchdog Timer Count Register (WTCNT) .....	8-4

## Table of Contents (Continued)

### Chapter 9 DMA

Overview.....	9-1
DMA Request Sources .....	9-1
DMA Operation.....	9-2
External DMA DREQ/DACK Protocol.....	9-2
Examples of Possible Cases .....	9-5
DMA Special Registers.....	9-6
DMA Initial Source Register (DISRC).....	9-6
DMA Initial Source Control Register (DISRCC) .....	9-6
DMA Initial Destination Register (DIDST) .....	9-7
DMA Initial Destination Control Register (DIDSTC) .....	9-7
DMA Control Register (DCON).....	9-8
DMA Status Register (DSTAT).....	9-10
DMA Current Source Register (DCSRC) .....	9-10
Current Destination Register (DCDST) .....	9-11
DMA Mask Trigger Register (DMASKTRIG) .....	9-12

## Table of Contents (Continued)

### Chapter 10      RTC (Real Time Clock)

Overview .....	10-1
Feature .....	10-1
Real Time Clock Operation .....	10-2
Leap Year Generator .....	10-2
Read/Write Registers .....	10-2
Backup Battery Operation .....	10-2
ALARM Function .....	10-3
TICK Time Interrupt .....	10-3
Round Reset Function .....	10-3
32.768kHz X-Tal Connection Example .....	10-3
Real Time Clock Special Registers .....	10-4
Real Time Clock Control Register (RTCCON) .....	10-4
TICK Time Count Register (TICNT) .....	10-4
RTC ALARM Control Register (RTCALM) .....	10-5
ALARM Second Data Register (ALMSEC) .....	10-6
ALARM Min Data Register (ALMMIN) .....	10-6
ALARM Hour Data Register (ALMHOUR) .....	10-6
ALARM Date Data Register (ALMDATE) .....	10-7
ALARM Mon Data Register (ALMMON) .....	10-7
ALARM Year Data Register (ALMYEAR) .....	10-7
BCD Second Register (BCDSEC) .....	10-8
BCD Minute Register (BCDMIN) .....	10-8
BCD Hour Register (BCDHOURL) .....	10-9
BCD Date Register (BCDDATE) .....	10-9
BCD Day Register (BCDDAY) .....	10-9
BCD Month Register (BCDMON) .....	10-10
BCD Year Register (BCDYEAR) .....	10-10



## Table of Contents (Continued)

### Chapter 11      **UART**

Overview.....	11-1
Features.....	11-1
Block Diagram .....	11-2
Uart Operation .....	11-3
Uart Special Registers.....	11-10
Uart Line Control Register .....	11-10
Uart Control Register.....	11-11
Uart FIFO Control Register.....	11-13
Uart Modem Control Register.....	11-14
Uart Tx/Rx Status Register .....	11-15
Uart Error Status Register .....	11-16
Uart FIFO Status Register .....	11-17
Uart Modem Status Register .....	11-18
Uart Transmit Buffer Register(Holding Register & FIFO Register) .....	11-19
Uart Receive Buffer Register (Holding Register & FIFO Register) .....	11-19
Uart Baud Rate Divisor Register .....	11-20
Uart Baud Rate Divisor Register .....	11-20

### Chapter 12      **IrDA Controller**

Overview.....	12-1
Feature .....	12-1
Block Diagram .....	12-2
External Interface Signals.....	12-2
Function Description.....	12-3
Core Initialization Procedure .....	12-9
Special Function Registers .....	12-10
IrDA Control Register (IrDA_CNT) .....	12-10
IrDA Mode Definition Register(IrDA_MDR) .....	12-11
IrDA Interrupt / DMA Configuration Register (IrDA_CNF).....	12-11
IrDA Interupt Enable Register (IrDA_IER) .....	12-12
IrDA Interupt Identification Register (IrDA_IIR) .....	12-13
IrDA Line Status Register (IrDA_LSR) .....	12-14
IrDA FIFO Control Register (IrDA_FCR).....	12-15
IrDA Preamble Length Register (IrDA_PLR).....	12-16
IrDA Total Number of Data Bytes Remained in Rx FIFO (IrDA_RXNO).....	12-17
IrDA Transmit Frame-Length Register Low (IrDA_TXFLH) .....	12-17
IrDA Transmit Frame-Length Register High (IrDA_TXFLH).....	12-17
IrDA Receiver Frame-Length Register Low (IrDA_RXFLH) .....	12-18
IrDA Receiver Frame-Length Register High (IrDA_RXFLH).....	12-18

# Table of Contents (Continued)

## Chapter 13 IIC-Bus Interface

Overview .....	13-1
The IIC-Bus Interface .....	13-2
Start and Stop Conditions .....	13-2
Data Transfer Format .....	13-4
ACK Signal Transmission .....	13-5
Read-Write Operation .....	13-6
Bus Arbitration Procedures .....	13-6
Abort Conditions .....	13-6
Configuring the IIC-Bus .....	13-6
Flowcharts of the Operations in Each Mode .....	13-7
IIC-Bus Interface Special Registers .....	13-11
Multi-Master IIC-Bus Control Register (IICCON) .....	13-11
Multi-Master IIC-Bus Control/Status Register (IICSTAT) .....	13-12
Multi-Master IIC-Bus Address Register (IICADD) .....	13-13
Multi-Master IIC-Bus Transmit/Receive Data Shift Register (IICDS) .....	13-13
Multi-Master IIC-Bus Sdaout Delay Register (SDADLY) .....	13-13

## Chapter 14 IIS-Bus Interface

Overview .....	14-1
Features .....	14-1
Block Diagram .....	14-1
Functional Descriptions .....	14-2
Transmit or Receive Only Mode .....	14-2
Dma Transfer .....	14-2
Transmit and Receive Mode .....	14-2
Audio Serial Interface Format .....	14-3
IIS-Bus Format .....	14-3
MSB(Left) Justified .....	14-3
Sampling Frequency and Master Clock .....	14-4
IIS-Bus Interface Special Registers .....	14-5
IIS Control Register (IISCON) .....	14-5
IIS Mode Register (IISMOD) .....	14-6
IIS Prescaler Register (IISPSR) .....	14-7
IIS FIFO Control Register (IISFCON) .....	14-7
IIS FIFO Register (IISFIFO) .....	14-8

## Table of Contents (Continued)

### Chapter 15 SPI Interface

Overview.....	15-1
Features.....	15-1
Block Diagram .....	15-2
SPI Operation .....	15-3
SPI Special Registers.....	15-6
SPI Control Register .....	15-6
SPI Status Register .....	15-7
SPI Pin Control Register.....	15-8
SPI Baud Rate Prescaler Register .....	15-9
SPI Tx Data Register.....	15-9
SPI Rx Data Register.....	15-9

### Chapter 16 AC97 Controller

Overview.....	16-1
Feature .....	16-1
AC97 Controller Operation.....	16-2
Block Diagram .....	16-2
Internal Data Path.....	16-3
Operation Flow Chart .....	16-4
AC-link Digital Interface protocol.....	16-5
AC-link Output Frame (SDATA_OUT).....	16-6
AC-link Input Frame (SDATA_IN).....	16-6
AC97 Powerdown.....	16-7
AC97 Controller Special Registers.....	16-9
AC97 Global Control Register (AC_GLBCTRL).....	16-9
AC97 Global Status Register (AC_GLBSTAT).....	16-10
AC97 Codec Command Register (AC_CODEC_CMD) .....	16-11
AC97 Codec Status Register (AC_CODEC_STAT).....	16-11
AC97 PCM Out/In Channel FIFO Address Register (AC_PCMADDR) .....	16-11
AC97 MIC in Channel FIFO Address Register (AC_MICADDR) .....	16-12
AC97 PCM Out/In Channel FIFO Data Register (AC_PCMDATA).....	16-12
AC97 MIC in Channel FIFO Data Register (AC_MICDATA).....	16-12

## Table of Contents (Continued)

### Chapter 17 USB Host Controller

Overview .....	17-1
USB Host Controller Special Registers .....	17-2
OHCI Registers for USB Host Controller .....	17-2

### Chapter 18 USB Device

Overview .....	18-1
Feature .....	18-1
USB Device Special Registers .....	18-3
FUNC_ADDR_REG .....	18-5
Power Management Register (PWR_REG) .....	18-6
Interrupt Register (EP_INT_REG, USB_INT_REG) .....	18-7
Interrupt Enable Register (EP_INT_EN_REG, USB_INT_REG) .....	18-9
Frame Number Register (FRAME_NUM1_REG, FRAME_NUM2_REG) .....	18-10
Index Register (INDEX_REG) .....	18-11
End Point0 Control Status Register (EP0_CSR) .....	18-12
End Point in Control Status Register (IN_CSR1_REG, IN_CSR2_REG) .....	18-13
End Point Out Control Status Register (OUT_CSR1_REG, OUT_CSR2_REG) .....	18-15
End Point FIFO Register (EPN_FIFO_REG) .....	18-17
Max Packet Register (MAXP_REG) .....	18-17
End Point Out Write Count Register (OUT_FIFO_CNT1_REG, OUT_FIFO_CNT2_REG) .....	18-18
DMA Interface Control Register (EPN_DMA_CON) .....	18-19
DMA Unit Counter Register (EPN_DMA_UNIT) .....	18-20
DMA FIFO Counter Register (EPN_DMA_FIFO) .....	18-21
DMA Total Transfer Counter Register (EPN_DMA_TTC_L, EPN_DMA_TTC_M, EPN_DMA_TTC_H) .....	18-22

## Table of Contents (Continued)

### Chapter 19 MODEM Interface

Overview.....	19-1
Features.....	19-2
Hardware Interface.....	19-2
Signal Description.....	19-2
Interrupt Ports.....	19-2
Address Mapping.....	19-3
Timing Diagram.....	19-4
Software Interface.....	19-5
Modem Interface Special Registers.....	19-6
Interrupt Request to AP Register (INT2AP).....	19-6
Interrupt Request to Modem Register (INT2MDM).....	19-6

### Chapter 20 General Purpose I/O Ports

Overview.....	20-1
Port Control Descriptions.....	20-3
Gpio Port Configuration Register For Normal Mode (GPCON_U, GPCON_M, GPCON_L).....	20-3
Gpio Port Data Register For Normal Mode (GPDAT).....	20-3
Gpio Port Pull-Pu Control Register for Normal Mode (GPPU).....	20-3
External Interrupt Control Register (Extintcn/ Eintfltn/ Eintmask/ Eintpend).....	20-3
Peripheral Port Pull-Up Control Register for Normal Mode (PERIPU).....	20-3
Alive Control Register (ALIVECON).....	20-4
Gpio Output Control Register for Sleep Mode (GPOEN_SLEEP).....	20-4
Gpio Pull-Up Control Register for Sleep Mode (GPPU_SLEEP).....	20-4
Peripheral Port Output Data Register for Sleep Mode (PERIDAT_SLEEPN).....	20-4
Peripheral Port Output Control Register for Sleep Mode (PERIOEN_SLEEPN).....	20-4
Peripheral Port Pull-Up Control Register for Sleep Mode (PERIPU_SLEEP).....	20-4
Reset Count Compare Register (RstCnt).....	20-4
General Purpose RAM Array (GPRAMn).....	20-4
I/O Port Control Register.....	20-5
GPIO Upper Port Control Register (GPCON_U).....	20-5
Gpio Middle Port Control Register (GPCON_M).....	20-6
Gpio Lower Port Control Register (GPCON_L).....	20-7
Gpio Port Data Register (GPDAT).....	20-8
Gpio Port Pull Up Resister Control Register (GPPU).....	20-8
External Interrupt Control Register (EXTINTC0).....	20-9

# Table of Contents (Continued)

## Chapter 20 General Purpose I/O Ports (Continued)

External Interrupt Control Register (EXTINTC1) .....	20-10
External Interrupt Control Register (EXTINTC2) .....	20-11
External Interrupt Filter Control Register (EINTFLTn) .....	20-12
External Interrupt Mask Register (EINTMASK) .....	20-13
External Interrupt Pending Register (EINTPEND) .....	20-14
Peripheral Port Pull up Control Register (PERIPU) .....	20-15
Alive Control Register (ALIVECON) .....	20-16
GPIO Output Data Register (GPDAT_SLEEP) .....	20-17
GPIO Output Control Register for Sleep Mode (GPOEN_SLEEP) .....	20-17
GPIO Pull up Control Register for Sleep Mode (GPPU_SLEEP) .....	20-17
Peripheral Port Output Data Register for Sleep Mode (PERIDAT_SLEEP0) .....	20-18
Peripheral Port Output Data Register for Sleep Mode (PERIDAT_SLEEP1) .....	20-19
Peripheral Port Output Control Register for Sleep Mode (PERIOEN_SLEEP0) .....	20-20
Peripheral Port Output Control Register for Sleep Mode (PERIOEN_SLEEP1) .....	20-21
Peripheral Port Pull up Control Register for Sleep Mode (PERIPU_SLEEP) .....	20-22
Reset Count Compare Register (RstCnt) .....	20-23
General Purpose RAM Array (GPRAMn) .....	20-24

## Chapter 21 Camera Interface

Overview .....	21-1
Features .....	21-2
External Interface .....	21-2
Signal Description .....	21-2
Timing Diagram .....	21-3
External Connection Guide .....	21-5
8-Bit Mode .....	21-5
16-Bit Mode .....	21-5
Camera Interface Operation .....	21-6
Two DMA Ports .....	21-6
Clock DOMAIN .....	21-7
Frame Memory Hierarchy .....	21-8
Memory Storing Method .....	21-9
Timing Diagram for Register Setting .....	21-10
Timing Diagram for Last IRQ .....	21-11
Software Interface .....	21-11

## Table of Contents (Continued)

### Chapter 21 Camera Interface (Continued)

Camera Interface Special Registers .....	21-12
Source Format Register .....	21-12
Window Option Register .....	21-13
Global Control Register .....	21-14
Y1 Start Address Register .....	21-14
Y2 Start Address Register .....	21-14
Y3 Start Address Register .....	21-15
Y4 Start Address Register .....	21-15
CB1 Start Address Register .....	21-15
CB2 Start Address Register .....	21-15
CB3 Start Address Register .....	21-16
CB4 Start Address Register .....	21-16
CR1 Start Address Register .....	21-16
CR2 Start Address Register .....	21-16
CR3 Start Address Register .....	21-17
CR4 Start Address Register .....	21-17
Codec Target Format Register .....	21-18
Codec DMA Control Register .....	21-19
Register Setting Guide for Codec Scaler and Preview Scaler .....	21-19
Codec Pre-Scaler Control Register 1 .....	21-22
Codec Pre-Scaler Control Register 2 .....	21-22
Codec Main-Scaler Control Register .....	21-22
Codec DMA Target Area Register .....	21-23
Codec Status Register .....	21-23
RGB1 Start Address Register .....	21-24
RGB2 Start Address Register .....	21-24
RGB3 Start Address Register .....	21-24
RGB4 Start Address Register .....	21-24
Preview Target Format Register .....	21-25
Preview DMA Control Register .....	21-25
Preview Pre-Scaler Control Register 1 .....	21-26
Preview Pre-Scaler Control Register 2 .....	21-26
Preview Main-Scaler Control Register .....	21-26
Preview DMA Target Area Register .....	21-27
Preview Status Register .....	21-27
Image Capture Enable Register .....	21-27

## Table of Contents (Continued)

### Chapter 22 MPEG-4 Video Codec

Overview .....	22-1
Feature .....	22-1
Block Diagram .....	22-2

### Chapter 23 MPEG-4 Motion Estimation

Overview .....	23-1
Feature .....	23-1
MPEG-4 Motion Estimation Operation .....	23-2
Block Diagram .....	23-2
Operation Flow .....	23-3
Result Data .....	23-4
MPEG-4 Motion Estimation Special Registers .....	23-5
Current Frame Start Address Register (ME_CFSA) .....	23-5
Previous Frame Start Address Register (ME_PFSA) .....	23-5
Motion Vector Start Address Register (ME_MVSA) .....	23-5
Command Register (ME_CMND) .....	23-6
Status & S/W Reset Register (ME_STAT_SWR) .....	23-7
Configuration Register (ME_CNFG) .....	23-8
Image Format Register (ME_IMGfmt) .....	23-8



## Table of Contents (Continued)

### Chapter 24 MPEG-4 Motion Compensation

Overview.....	24-1
Feature .....	24-1
MPEG-4 Motion Compensation Operation .....	24-2
Block Diagram .....	24-2
Operation Flow .....	24-3
Configuration of QCIF/CIF Frame .....	24-4
MPEG-4 Motion Compensation Special Registers .....	24-6
Previous Frame Y Start Address Register for the Encoder (MC_PFYSA_ENC).....	24-6
MCED Frame Y Start Address Register for the Encoder (MC_MFYSA_ENC).....	24-6
Previous Frame Y Start Address Register for the Decoder (MC_PFYSA_DEC).....	24-6
MCED Frame Y Start Address Register for the Decoder (MC_MFYSA_DEC).....	24-6
Previous Frame Cb Start Address Register for the Encoder (MC_PFCbSA_ENC) .....	24-7
Previous Frame Cr Start Address Register for the Encoder (MC_PFCrSA_ENC).....	24-7
MCED Frame Cb Start Address Register for the Encoder (MC_MFCbSA_ENC).....	24-7
MCED Frame Cr Start Address Register for the Encoder (MC_MFCrSA_ENC).....	24-7
Previous Frame Cb Start Address Register for the Decoder (MC_PFCbSA_DEC) .....	24-8
Previous Frame Cr Start Address Register for the Decoder (MC_PFCrSA_DEC).....	24-8
MCED Frame Cb Start Address Register for the Decoder (MC_MFCbSA_DEC).....	24-8
MCED Frame Cr Start Address Register for the Decoder (MC_MFCrSA_DEC).....	24-8
Motion Vector Start Address Register for the Encoder (MC_MVSA_ENC).....	24-9
Motion Vector Start Address Register for the Decoder (MC_MVSA_DEC).....	24-9
Command Register (MC_CMND).....	24-10
Status & S/W Reset Register (MC_STAT_SWR).....	24-11
Configuration Register (MC_CNFG) .....	24-12
Image Format Register (MC_IMGfmt) .....	24-12

## Table of Contents (Continued)

### Chapter 25      MPEG-4 DCTQ

Overview .....	25-1
Features .....	25-2
Timing Diagram.....	25-2
Separated Clock Domain .....	25-3
DCT .....	25-3
IDCT.....	25-3
Quantisation .....	25-4
DEQuantisation.....	25-4
Frame Memory Map.....	25-5
Q-Information .....	25-6
Bit Format.....	25-7
Transposed Coefficeint Output .....	25-8
Software Interface.....	25-8
MPEG-4 DCTQ Special Registers.....	25-9
Current Frame Y Start Address Register.....	25-9
Current Frame Cb Start Address Register.....	25-9
Current Frame Cr Start Address Register .....	25-9
Reference Frame Y Start Address Register .....	25-10
Reference Frame Cb Start Address Register.....	25-10
Reference Frame Cr Start Address Register.....	25-10
Dctqed Frame Y Start Address Register .....	25-10
Dctqed Frame Cb Start Address Register .....	25-11
Dctqed Frame Cr Start Address Register .....	25-11
Quantisation Factor Start Address Register .....	25-11
Image Size Register.....	25-11
SHQ Register .....	25-12
Control Register .....	25-13

### Chapter 26      VLX

Overview .....	26-1
Feature .....	26-1
MPEG-4 VLX (Variable Length Coding, Decoding) Operation.....	26-2
MPEG-4 VLX (Variable Length Coding, Decoding) Operation.....	26-2
VLC .....	26-2
Entropy Coder.....	26-4
VLD .....	26-6
VLX (VLC and VLD) Special Registers .....	26-10
VLX Common SFR .....	26-10
Frame Start Addr.....	26-11
VLX Control Register (VLX_CON).....	26-12
VLD Control Register (VLD_CON) .....	26-13
VLX Output Register 1 (VLX_CON 1) – Read Only .....	26-14
VLX Output Register 2 (VLX_CON 2) – Read Only .....	26-14

## Table of Contents (Continued)

### Chapter 27 Post Processor

Overview.....	27-1
Overall Features .....	27-2
A Source and Destination Image Data Format .....	27-3
Image Size and Scale Ratio .....	27-6
DMA Operation of Source and Destination Image.....	27-8
Starting and Terminating of Post Processor .....	27-11
Register File Lists.....	27-12
Pre-Scale Image Size Register .....	27-13
Source Image Size Register.....	27-14
Destination Image Size Register .....	27-15
DMA Start Address Register .....	27-15
DMA End Address Register.....	27-16
Offset Register.....	27-16

### Chapter 28 LCD Controller

Overview.....	28-1
Features.....	28-1
External Interface Signal .....	28-2
Block Diagram .....	28-3
Timing Controller Operation .....	28-4
Video Operation .....	28-5
OSD (On-Screen Display): Overlay.....	28-5
Color-Key Function .....	28-6
Dual Buffer .....	28-7
256 Palette Usage (TFT) .....	28-12
Virtual Display.....	28-15
Register Description.....	28-16
Memory Map.....	28-16

# Table of Contents (Continued)

## Chapter 29 Key PAD I/F

Overview .....	29-1
Keypad Control Register .....	29-2
Keypad Control Registers (KEYDAT, KEYPUP) .....	29-2
Keypad Interrupt Control Register .....	29-2
Debouncing Filter .....	29-3
Keypad Filter Control Register ( KEYFLT ).....	29-3
Keypad Manual Scan Control Register (YMAN).....	29-4

## Chapter 30 ADC & Touch Screen Interface

Overview .....	30-1
Features .....	30-1
ADC & Touch Screen Interface Operation .....	30-2
Block Diagram.....	30-2
Example for Touch Screen .....	30-3
Function Descriptions .....	30-4
Function Descriptions .....	30-4
ADC and Touch Screen Interface Special Registers .....	30-7
ADC Control Register (ADCCON) .....	30-7
ADC Touch Screen Control Register (ADCTSC) .....	30-8
ADC Start Delay Register (ADCPLY) .....	30-9
ADC Conversion Data Register (ADCDA) .....	30-10
ADC Conversion Data Register (ADCDB) .....	30-11

## Table of Contents (Continued)

### Chapter 31 Secure Digital Interface

Overview.....	31-1
Feature .....	31-1
Block Diagram .....	31-2
SDI Operation.....	31-3
SDIO Operation.....	31-4
SDI Special Registers .....	31-5
SDI Control Register (SDICON).....	31-5
SDI Baud Rate Prescaler Register (SDIPRE).....	31-6
SDI Command Argument Register (SDICARG).....	31-6
SDI Command Control Register (SDICCON).....	31-6
SDI Command Status Register (SDICSTA) .....	31-7
SDI Response Register0 (SDIRSP0) .....	31-7
SDI Response Register1 (SDIRSP1) .....	31-7
SDI Response Register2 (SDIRSP2).....	31-8
SDI Response Register3 (SDIRSP3).....	31-8
SDI Data / Busy Timer Register (SDIDTIMER).....	31-8
SDI Block Size Register (SDIBSIZE).....	31-8
SDI Data Control Register (SDIDCON).....	31-9
SDI Data Remain Counter Register (SDIDCNT).....	31-10
SDI Data Status Register (SDIDSTA) .....	31-11
SDI FIFO Status Register (SDIFSTA) .....	31-12
SDI Interrupt Mask Register (SDIIMSK).....	31-13
SDI Data Register (SDIDATn).....	31-14

### Chapter 32 Memory Stick

Overview.....	32-1
Features.....	32-1
Memory Stick Protocol.....	32-2
Mandatory Hardware Configuration .....	32-2
Host Block Pin Description .....	32-3
Memory Stick Special Registers .....	32-4
Prescaler Control (MSPRE) Register .....	32-4
FIFO Interrupt Control (MSFINTCON) Register .....	32-4
Transfer Protocol Command (TP_CMD) Register .....	32-5
Control and Status (CTRLSTA) Register .....	32-6
Data FIFO (DAT_FIFO) Register.....	32-7
Interrupt Control and Status (INTCTRLSTA) Register .....	32-7
INS Port Control (INSCON) Register .....	32-8
Auto Command/POL Control (ACMD_CON) Register .....	32-8
Auto Transfer Protocol Command (ATP_CMD) Register.....	32-8

# Table of Contents (Continued)

## Chapter 33 Clock & Power Management

Overview .....	33-1
Function Description .....	33-2
Power Saving Modes .....	33-9
Clock Generator & Power Management Special Register .....	33-13
Lock Time Count Register (LOCKTIME) .....	33-13
X-Tal Oscillation Wait Register (XTALWSET) .....	33-13
PII Control Register (MPLLCON, UPLLCON) .....	33-14
Clock Control Register (CLKCON) .....	33-15
Clock Source Control Register (CLKSRC) .....	33-17
Clock Divider Control Register (CLKDIVN) .....	33-18
Power Management Control Register (PWRMAN).....	33-18
Softreset Control Register (SOFTRESET) .....	33-19

## Chapter 34 Mechanical Data

Package Dimensions .....	34-1
--------------------------	------

# List of Figures

Figure Number	Title	Page Number
1-1	An Overall Block Diagram of the S3C24A0A .....	1-8
1-2	337-Pin FBGA Pin Assignment .....	1-9
1-3	Address map.....	1-38
2-1	SRAM Controller Address Mapping .....	2-1
2-2	SRAM Controller Block Diagram.....	2-2
2-3	Memory Interface Block Diagram .....	2-3
2-4	XrWAITn Pin Operation .....	2-4
2-5	Programmable Access Cycle .....	2-5
3-1	Memory Interface with 16-bit SDRAM (4Mx16, 4banks).....	3-4
3-2	Memory Interface with 16-bit SDRAM (4Mx16 × 2ea, 4banks).....	3-4
3-3	SDRAM Timing Diagram .....	3-5
4-1	NAND Flash Controller Block Diagram .....	4-3
4-2	NAND Flash Controller Boot Loader Block Diagram.....	4-4
4-3	NAND Flash Controller Operation Mode Block Diagram .....	4-5
4-4	Auto Mode Timing Diagram (TACLS = 1, TWRPH0 = 0, TWRPH1 = 0) .....	4-5
4-5	NAND Flash Controller Auto Load Timing Diagram (TWRPH0 = 0, TWRPH1 = 0) .....	4-6
4-6	NAND Flash Controller Auto Store Timing Diagram (TWRPH0 = 0, TWRPH1 = 0).....	4-7
4-7	8-bit NAND Flash Memory Interface .....	4-11
4-8	Two 8-bit NAND Flash Memory Interface.....	4-11
4-9	16-bit NAND Flash Memory Interface .....	4-12
5-1	Configuration of MATRIX and Memory Sub-System.....	5-1
6-1	Priority Generating Block.....	6-4
7-1	16-bit PWM Timer Block Diagram .....	7-2
7-2	Timer operations.....	7-3
7-3	Example of Double Buffering Feature .....	7-4
7-4	Example of a Timer Operation.....	7-5
7-5	Example of PWM .....	7-6
7-6	Inverter On/Off .....	7-7
7-7	The Wave Form When a Dead Zone Feature is Enabled.....	7-8
7-8	The Timer4 DMA Mode Operation .....	7-9

## List of Figures (Continued)

Figure Number	Title	Page Number
8-1	Watchdog Timer Block Diagram .....	8-2
9-1	Basic DMA Timing Diagram .....	9-3
9-2	Demand/Handshake Mode Comparison .....	9-3
9-3	Burst 4 Transfer Size .....	9-4
9-4	Single service, Demand Mode, Single Transfer Size .....	9-5
9-5	Single service, Handshake Mode, Single Transfer Size .....	9-5
9-6	Whole service, Handshake Mode, Single Transfer Size .....	9-5
10-1	Real Time Clock Block Diagram .....	10-2
11-1	UART Block Diagram (with FIFO).....	11-2
11-2	UART AFC Interface .....	11-3
11-3	Example showing UART Receiving 5 Characters with 2 Errors.....	11-6
11-4	IrDA Function Block Diagram .....	11-8
11-5	Serial I/O Frame Timing Diagram (Normal UART).....	11-9
11-6	Infrared Transmit Mode Frame Timing Diagram .....	11-9
11-7	Infrared Receive Mode Frame Timing Diagram .....	11-9
11-8	nCTS and Delta CTS Timing Diagram.....	11-18
12-1	Block Diagram.....	12-2
12-2	Fir Modulation Process .....	12-4
12-3	Fir Demodulation Process .....	12-5
12-4	Pulse Modulation in MIR Mode.....	12-6
12-5	Mir Modulation Process .....	12-7
12-6	Mir Demodulation Process.....	12-8
12-7	General Program Flowchart.....	12-9
13-1	IIC-Bus Block Diagram.....	13-2
13-2	Start and Stop Condition.....	13-3
13-3	IIC-Bus Interface Data Format .....	13-4
13-4	Data Transfer on the IIC-Bus .....	13-5
13-5	Acknowledge on the IIC-Bus .....	13-5
13-6	Operations for Master / Transmitter Mode.....	13-7
13-7	Operations for Master / Receiver Mode.....	13-8
13-8	Operations for Slave / Transmitter Mode.....	13-9
13-9	Operations for Slave / Receiver Mode.....	13-10



## List of Figures (Continued)

Figure Number	Title	Page Number
14-1	IIS-Bus Block Diagram .....	14-1
14-2	IIS-Bus and MSB(Left)-justified Data Interface Formats .....	14-4
15-1	SPI Block Diagram .....	15-2
15-2	SPI Transfer Format .....	15-4
16-1	AC97 Block Diagram .....	16-2
16-2	Internal Data Path .....	16-3
16-3	AC97 Operation Flow Chart .....	16-4
16-4	Bi-directional AC-link Frame with Slot Assignments .....	16-5
16-5	AC-link Output Frame .....	16-6
16-6	AC-link Input Frame .....	16-6
16-7	AC97 Powerdown Timing .....	16-7
16-8	AC97 Power down/Power up Flow .....	16-8
17-1	USB Host Controller Block Diagram .....	17-1
18-1	USB Device Block Diagram .....	18-2
19-1	Modem Interface Overview .....	19-1
19-2	Modem Interface Address Mapping .....	19-3
19-3	Modem Interface Write Timing Diagram .....	19-4
19-4	Modem Interface Read Timing Diagram .....	19-5
21-1	Camera Interface Overview .....	21-1
21-2	ITU-R BT 601 Input Timing Diagram .....	21-3
21-3	ITU-R BT 656 Input Timing Diagram .....	21-3
21-4	IO Connection Guide .....	21-5
21-5	Two DMA Ports .....	21-6
21-6	Clock Generation .....	21-7
21-7	Ping-pong Memory Hierarchy .....	21-8
21-8	Memory Storing Style .....	21-9
21-9	Timing Diagram for Register Setting .....	21-10
21-10	Timing Diagram for Last IRQ .....	21-11
21-11	Window Offset Scheme .....	21-13
21-12	Image Mirror and Rotation .....	21-18
21-13	Scaling scheme .....	21-20

## List of Figures (Continued)

Figure Number	Title	Page Number
22-1	MPEG-4 Video CODEC Block Diagram .....	22-2
23-1	MPEG-4 Motion Estimation Block Diagram .....	23-2
23-2	Memory Map of Y (Luminance) Image for Current and Previous Frames .....	23-3
23-3	Motion Estimation Result Data .....	23-4
24-1	MPEG-4 Motion Compensation Block Diagram .....	24-2
24-2	Y/Cb/Cr Image Memory Map of Original and Padded Frames .....	24-3
24-3	Y/Cb/Cr Configuration for QCIF/CIF Original Frame .....	24-4
24-4	Y/Cb/Cr Configuration for QCIF/CIF Padded Frame .....	24-5
24-5	Motion Vector Configuration for QCIF/CIF Image .....	24-5
25-1	DCTQ Overview .....	25-1
25-2	DCTQ Operation Timing Diagram .....	25-2
25-3	DCTQ clock domain .....	25-3
25-4	DCTQ Frame Memory Map in QCIF Case .....	25-5
25-5	Q-Information Structure .....	25-6
25-6	DCTQ Bit-Format .....	25-7
25-7	Transposed Coefficient Output for MB .....	25-8
26-1	VLX Top Interface Block Diagram .....	26-2
26-2	ZigZag Scanning Method .....	26-3
26-3	Previous Neighboring Blocks Used in DC Prediction .....	26-4
26-4	VLC output bit stream format .....	26-5
26-5	VLC Start, Busy, And Interrupt Signal Timing Diagram .....	26-6
26-6	VLD Bit Stream H/W and S/W Interface Format .....	26-6
26-7	External Memory Amount in VLD Mode .....	26-7
26-8	VLD Output Coefficient Format .....	26-7
26-9	MSB is First Bit Value in Output Bit Stream .....	26-8
26-10	VLD Flow Chart and S/W and H/W Processing Partition .....	26-9
26-11	Start Signal, Busy Signal and Interrupt Signal in VLD Mode .....	26-9

## List of Figures (Continued)

Figure Number	Title	Page Number
27-1	Block Diagram of Post Processor.....	27-1
27-2	Data Format Stored in External Memory.....	27-4
27-3	Byte and Half-Word Organization.....	27-4
27-4	Sampling Position of YCbCr420 and YCbCr422 Format (X: Luma Sample and O: Chroma Sample).....	27-5
27-5	Source Destination Image Size.....	27-6
27-6	Start and End Address Set According to Memory Allocation Type.....	27-8
27-7	Offset for (a) Source Image for Zoom In/Out Operation and (b) Destination Image for PIP Applications.....	27-10
27-8	Start and Termination of the Operation of Post Processor.....	27-11
28-1	LCD Controller Block Diagram.....	28-3
28-2	Clock Selection.....	28-4
28-3	OSD Procedure.....	28-6
28-4	Blending and Color Key Function of OSD.....	28-7
28-5	16BPP Display Types.....	28-13
28-6	TFT LCD Timing Example.....	28-14
28-7	Example of Scrolling in Virtual Display.....	28-15
29-1	Key Matrix Interface Guide.....	29-1
30-1	ADC and Touch Screen Interface Functional Block Diagram.....	30-2
30-2	Example of ADC and Touch Screen Interface.....	30-3
31-1	SDI Block Diagram.....	31-2
32-1	Memory Stick Write Packet.....	32-2
32-2	Memory Stick Read Packet.....	32-2
33-1	Clock Generator Block Diagram.....	33-2
33-2	PLL (Phase-Locked Loop) Block Diagram.....	33-3
33-3	Power-On Reset Sequence.....	33-5
33-4	The Case that Changes Slow Clock by Setting PMS Value.....	33-6
33-5	The Clock Distribution Block Diagram.....	33-8
33-6	Entering STOP Mode and Exiting STOP mode (Wake-up).....	33-10
33-7	Power mode state diagram.....	33-11
34-1	337-FBGA-1313 Package Dimension 1 (Top View).....	34-1
34-2	337-FBGA-1313 Package Dimension 2 (Bottom View).....	34-2



# List of Tables

Table Number	Title	Page Number
1-1	337-Pin FBGA Pin Assignments – Pin Number Order .....	1-10
1-2	337-Pin FBGA Pin Assignments.....	1-14
3-1	Supported SDRAM Configuration .....	3-2
4-1	Advance NAND Flash Controller Configuration (word means 16-bit in this table).....	4-2
4-2	2K Byte Main Area ECC Parity Code Assignment Table .....	4-9
4-3	16 Byte SPARE AREA ECC Parity Code Assignment Table .....	4-9
9-1	DMA Request Sources for Each Channel .....	9-1
11-1	Interrupts in Connection with FIFO.....	11-5
14-1	CODEC Clock (IISCDCLK = 256 or 384fs) .....	14-4
14-2	Usable Serial Bit Clock Frequency (IISCLK = 16 or 32 or 48fs) .....	14-4
16-1	AC97 Block Diagram .....	16-2
16-2	Internal Data Path.....	16-3
16-3	AC97 Operation Flow Chart .....	16-4
16-4	Bi-directional AC-link Frame with Slot Assignments .....	16-5
16-5	AC-link Output Frame .....	16-6
16-6	AC-link Input Frame.....	16-6
16-7	AC97 Powerdown Timing .....	16-7
16-8	AC97 Power down/Power up Flow .....	16-8
19-1	Modem Interface Signal Description .....	19-2
19-2	Interrupt Ports And Interrupt-Request/Clear Conditions .....	19-2
19-3	Modem Interface Write Timing .....	19-4
19-4	Modem Interface Read Timing .....	19-5
20-1	S3C24A0A Port Configuration Overview.....	20-2
21-1	Camera Interface Signal Description.....	21-2
21-2	Video Timing Reference Codes of ITU-656 Format.....	21-4

## List of Tables (Continued)

Table Number	Title	Page Number
23-1	Example of Sizes of Y Image and Offset for QCIF and CIF .....	23-3
24-1	Sizes of Y/Cb/Cr Image and Offset for QCIF and CIF .....	24-3
27-1	Mode Configuration for Video/Graphic Source Format and the Corresponding Data Format .....	27-3
28-1	Relation Between XvVCLK and CLKVAL (TFT, Freq. of Video Clock Source = 60 MHz) .....	28-5
28-2	6:6:6 Palette Data Format .....	28-12
28-3	5:6:5 Palette Data Format .....	28-12
28-4	5:5:5:1 Palette Data Format .....	28-12
30-1	Condition of Touch Screen Panel Pads in Separate X/Y Position Conversion Mode .....	30-4
30-2	Condition of Touch Screen Panel Pads in Auto (Sequential) X/Y Position Conversion Mode 30-5	
30-3	Condition of Touch Screen Panel Pads in Waiting for Interrupt Mode .....	30-5
33-1	Clock Source Selection for the Internal PLLs and Clock Generation Logic .....	33-2
33-2	Recommended operation conditions .....	33-4
33-3	DC Electrical Characteristics .....	33-4
33-4	AC Electrical Characteristics .....	33-4
33-5	The Status of PLL and ARMCLK After Wake-Up .....	33-11
33-6	Power Saving Mode Entering/Exiting condition .....	33-12
33-7	PLL value selection table .....	33-14

# 1

## PRODUCT OVERVIEW

### ARCHITECTURAL OVERVIEW

The S3C24A0A is a 16/32-bit RISC microprocessor, designed to provide a cost-effective, low power, and high performance micro-controller solution for mobile phones and general applications. To provide a sufficient H/W performance for the 2.5G & 3G communication services, the S3C24A0A adopts dual-32-bit bus architecture and includes many powerful hardware accelerators for the motion video processing, serial communications, and etc. For the real time video conferencing, an optimized MPEG4 H/W Encoder/Decoder is integrated.

To reduce total system cost and enhance overall functionality, the S3C24A0A also includes following components: separate 16KB Instruction and 16KB Data Cache, MMU to handle virtual memory management, LCD controller (TFT), Camera Interface, MPEG-4 ME, MC, DCTQ, NAND Flash Boot loader, System Manager (power management & etc.), SDRAM controller, 2-ch UART, 4-ch DMA, 4-ch Timers, General I/O Ports, IIC-BUS interface, USB Host, SD Host & Multi-Media Card Interface, Memory Stick Interface, PLL for clock generation & etc. The S3C24A0A can be used as a most powerful Application Processor for mobiles phones. For this application, the S3C24A0A has a Modem Interface to communicate with various Modem Chips.

The S3C24A0A is developed using an ARM926EJ-S core, advanced 0.13um CMOS standard cells and memory compilers. Its low-power, simple, elegant and fully static-design scheme is particularly suitable for cost-sensitive and power-sensitive applications. Also, the S3C24A0A adopts a de-facto standard bus architecture – the AMBA (Advanced Microcontroller Bus Architecture).

One of the outstanding features of the S3C24A0A is its CPU core, a 16/32-bit ARM926EJ-S RISC processor designed by ARM, Ltd. The ARM926EJ-S is a single chip MCU and Java enabled microprocessor. The ARM926EJ-S also implements the MMU, the AMBA BUS, and the Harvard cache architecture with separate 16KB instruction and 16KB data caches, each cache with an 8-word line length.

By providing a complete set of common system peripherals, the S3C24A0A minimizes overall system costs and eliminates the need to configure additional components.

## FEATURES

This section will explain the features of the S3C24A0A. Figure 1-1 is an overall block diagram of the S3C24A0A.

### MICROPROCESSOR AND OVERALL ARCHITECTURE

- SoC (System-on-Chip) for mobile phones and general embedded applications.
- 16/32-Bit RISC architecture and powerful instruction set with ARM926EJ-S CPU core.
- ARM's Jazelle Java technology enhanced ARM architecture MMU to support WinCE, Symbian and Linux
- Instruction cache, data cache, write buffer and Physical address TAG RAM to reduce the effect of main memory bandwidth and latency on performance
- 4 way set-associative cache with I-Cache (16KB) and D-Cache (16KB).
- 8-words per line with one valid bit and two dirty bits per line
- Pseudo random or round robin replacement algorithm.
- Write through or write back cache operation to update the main memory.
- The write buffer can hold 16 words of data and four addresses.
- ARM926EJ-S core supports the ARM debug architecture
- Internal AMBA (Advanced Microcontroller Bus Architecture) (AMBA2.0, AHB/APB)
- Dual AHB bus for high-performance processing (AHB-I & AHB-S)

### MEMORY SUBSYSTEM

- High bandwidth Memory subsystem with two access channels (accesses from two AHB buses) and three-channel memory ports
- Double the bandwidth with the simultaneous access capability
- ROM/SRAM/NOR-Flash/NAND-Flash channel
- One SDRAM channels
- Up to 1GB Address space
- Low-power SDRAM interface support : Mobile SDRAM function
  - DS: Driver Strength Control
  - TCSR: Temperature Compensated Self-Refresh Control
  - PASR: Partial Array Self-Refresh Control
- NAND Flash Boot Loader with the ECC circuitry to support booting from NAND Flash
  - 4KB Stepping Stone
  - Support 1G, 2G bit NAND Flash



## GENERAL PERIPHERALS

- Interrupt Controller
  - 61 Interrupt sources  
(1 Watch Dog Timer, 5 Timer, 6 UART, 18 External Interrupts, 4 DMA, 2 RTC, 3 ADC, 1 I2C, 1 AC97, 1 NAND Flash, 1 IrDA, 1 Memory Stick, 2 SPI, 1 SDI, 2 USB (Host and Device), 1 Keypad, 1 Modem Interface, 2 Camera Interface, 4 MPEG, 2 LCD, 1 Battery Fault, 1 Post)
  - Level/Edge mode on external interrupt source.
  - Programmable polarity of edge and level.
  - Supports FIQ (Fast Interrupt request) for very urgent interrupt request.
- Timer with PWM (Pulse Width Modulation)
  - 4-ch 16-bit Timer with PWM / 1-ch 16-bit internal timer with DMA-based or interrupt-based operation
  - Programmable duty cycle, frequency, and polarity
  - Dead-zone generation.
  - Support external clock source.
- 16-bit Watchdog Timer.
  - Interrupt request or system reset at time-out.
- 4-ch DMA controller.
  - Support memory to memory, IO to memory, memory to IO, and IO to IO
  - Burst transfer mode to enhance the transfer rate.
- RTC (Real Time Clock)
  - Full clock feature: msec, sec, min, hour, day, date, week, month, year.
  - 32.768 KHz operation
  - Alarm interrupt
  - Time-tick interrupt

## SERIAL COMMUNICATION

- UART
  - 2-channel UART with DMA-based or interrupt-based operation
  - Supports 5-bit, 6-bit, 7-bit, or 8-bit serial data transmit/receive
  - Supports external clock for the UART operation (XuCLK)
  - Programmable baud rate
  - Supports IrDA 1.0
  - Loop back mode for testing
  - Each channel has internal 64-byte Tx FIFO and 64-byte Rx FIFO
- IrDA
  - Support IrDA 1.1 (1.152Mbps and 4Mbps)
  - Support FIFO operation in the MIR and FIR mode
  - Configurable FIFO Size (16-byte or 64-byte)
  - Support Back-to-Back Transactions
  - Support Software Selection Temic-IBM or HP Transceiver
  - Support Little-endian access
- IIC-Bus Interface
  - 1-ch Multi-Master IIC-Bus
  - Serial, 8-bit oriented and bi-directional data transfers can be made at up to 100 Kbit/s in the standard mode

- IIS-Bus Interface
  - 1-ch IIS-bus for the audio-codec interface with DMA-based operation
  - Serial, 8/16-bit per channel data transfers
  - 128 Bytes (64-Byte + 64-Byte) FIFO for receive/transmit
  - Supports IIS format and MSB-justified data format
- SPI Interface
  - 2-ch Serial Peripheral Interface Protocol version 2.11 compatible
  - 2x8 bits Shift register for receive/transmit.
  - DMA-based or interrupt-based operation.
- AC97 Audio-CODEC Interface
  - 48kHz 16-bit sampling
  - 1-ch stereo PCM inputs / 1-ch stereo PCM outputs / 1-ch MIC input
- USB Host
  - 2-port USB Host
  - Complies with OHCI Rev. 1.0
  - Compatible with the USB Specification version 1.1
- USB Device
  - 1-port USB Device
  - 5 End-points for USB Device
  - Compatible with the USB Specification version 1.1

## PARALLEL COMMUNICATION

- Modem Chip Interface
  - 8-bit Asynchronous SRAM interface-style interface
  - On-chip 2KB dual-ported SRAM buffer
  - Interrupt Request for Data Exchange
  - Programmable Interrupt Port Address
- 32-bit GPIO
  - Fully configurable 32-bit GPIO

## IMAGE AND VIDEO PROCESSING

- Camera Interface
  - ITU601/ITU656 YCbCr 4:2:2 8/16-bit mode
  - Image down scaling capability for variable applications
  - Digital Zoom-In
  - Image X, Y-flip, 180 rotation
  - Input Image Window Cut
  - Two master for dedicated DMA operation
  - Programmable burst length for DMA operation
  - Programmable polarity of video sync signals
  - Wide horizontal line buffer (maximum 2048 pixel)
  - Up to 4M pixel resolution support for scaled image (image preview or motion video capturing) and 16M pixel for unscaled image (JPEG)
  - Format conversion from YCrCb 4:2:2 to 4:2:0 for codec, and to RGB 4:4:4 for preview

- Hardware Accelerated MPEG4 Video Encoding/Decoding
  - A AHB Interface
  - Realtime MPEG-4 Video Encoding & Decoding
  - Up to Simple Profile at Level 3 (352x288 at 30fps)
  - Supports H.263 Base Line
- MPEG-4 ME (Motion Estimation)
  - Highly optimized hard-wired engine
  - Unrestricted Mode and Advanced Prediction Mode (4MV)
  - Use the advanced MRMCS algorithm
  - Half-pel search
  - Programmable Image size up to 2048x2048
  - Padding for Macro-block basis
  - Search Range: [-16, 15.5]
  - Intra/Inter Mode Decision MC (Motion Compensation)
- MC (Motion Compensation)
  - Highly optimized hard-wired engine
  - Unrestricted Mode and Advanced Prediction Mode (4MV)
  - Half-pel search
  - Programmable Image size up to 2048x2048
  - Dedicated DMA
  - Macroblock-based Pading
  - Search Range: [-64, 63.5]
- DCTQ
  - DCT/IDCT/Q/IQ operations
  - AMBA AHB Interface
  - Support MPEG-4 Simple Profile Level 3 / H.263 Base-Line
  - Support programmable image size up to 4096x4096
  - Macroblock-based processing
  - Rate Control by Qp Information
  - Local DMA
  - Support MPEG-4 Encoding / Decoding
  - Support JPEG DCT / IDCT Operation
  - Operation unit : 1MB(MacroBlock) ~ 1 Frame
- VLX
  - VLC/VLD operations
  - AMBA AHB Interface
  - Support MPEG4 Simple Profile Level 3/ H.263. Baseline
  - Macro block-based processing
  - Dedicated DMA
  - Only DCTQ coefficient VLC/VLD operation
  - Only DC prediction operation in VLC

- Post Processor
  - Dedicate DMA with Offset Address
  - 3 Channel Scaling Pipelines for Video/Graphis Signal
  - Input Format: YCbCr4:2:0, YCbCr4:2:2, or RGB 16b/24b
  - Output Format: RGB 16b/24b
  - Programmable Image Size (Source up to 4096x4096, Destination up to 2048x2048)
  - Programmable Scale Ratio (Up-scale: up to Max. Destination Size, Down-scale: ~>1/64 in X & Y)
  - Format Conversion for Video Signal (YCbCr4:2:0 or YCbCr4:2:2)
  - Color Space Conversion (YCbCr2RGB)
  - Separate Processing Clock from AHB Interface Clock

## DISPLAY CONTROL

- TFT LCD Interface
  - 18-bit Parallel or 6bit\*3 Interface
  - 1/2/4/8-bpp Palletized or 8/16/18-bpp Non-Palletized Color-TFF support
  - Supports 640x480, 320x240, 176x192 and others
  - Up to 16 Mbyte virtual screen size
  - Supports Multiple Virtual Display Screen (Supports Hardware Horizontal/Vertical Scrolling)
  - Programmable timing control for different display panels
  - Dual Buffer
- OSD (On Screen Display)
  - Realtime overlay plane multiplexing
  - Programmable OSD window positioning
  - Per-pixel alpha blending for 18-bpp OSD images
  - Fixed alpha-value for 8-/16-/18-bpp OSD image
  - 56-level alpha blending
  - 24-bit color key support
  - Dual buffer

## INPUT DEVICES

- Keypad Interface
  - Provides internal debouncing filter
  - 5-input, 5-output pins for key scan in/out
- A/D Converter and Touch Screen Interface
  - 8-ch multiplexed ADC
  - Max. 500K samples/sec and 10-bit resolution

## STORAGE DEVICES

- SD Host
  - Compatible with SD Memory Card Protocol version 1.0
  - Compatible with SDIO Card Protocol version 1.0
  - 64 Bytes FIFO for Tx/Rx
  - DMA based or Interrupt based operation
  - Compatible with Multimedia Card Protocol version 2.11
- Memory Stick Host
  - Memory Stick version 1.3 compliant

## SYSTEM MANAGEMENT

- Little Endian format support
- System operating clock generation
  - Two on-chip PLLs, MPLL & UPLL
  - MPLL generates the system reference clock, [200MHz@1.3V](#)
  - UPLL generates clocks for the USB Host/Device, IrDA and Camera
- Power Management
  - Clock-off control for individual components
  - Various power-down modes are available such as IDLE, STOP and SLEEP
  - Wake-up by one of external interrupts or by the RTC alarm interrupt, etc.

## ELECTRICAL CHARACTERISTICS

- Operating Conditions
  - Supply Voltage for Logic Core: 1.3V  $\pm$  0.05V
  - External Memory Interface: 1.9V / 2.5V / 3.3V
  - External I/O Interface: 3.3V
- Operational Frequency
  - Max. 200MHz@1.3V

## PACKAGE

- 337-pin FBGA (0.5mm pitch, 13mm x 13mm)

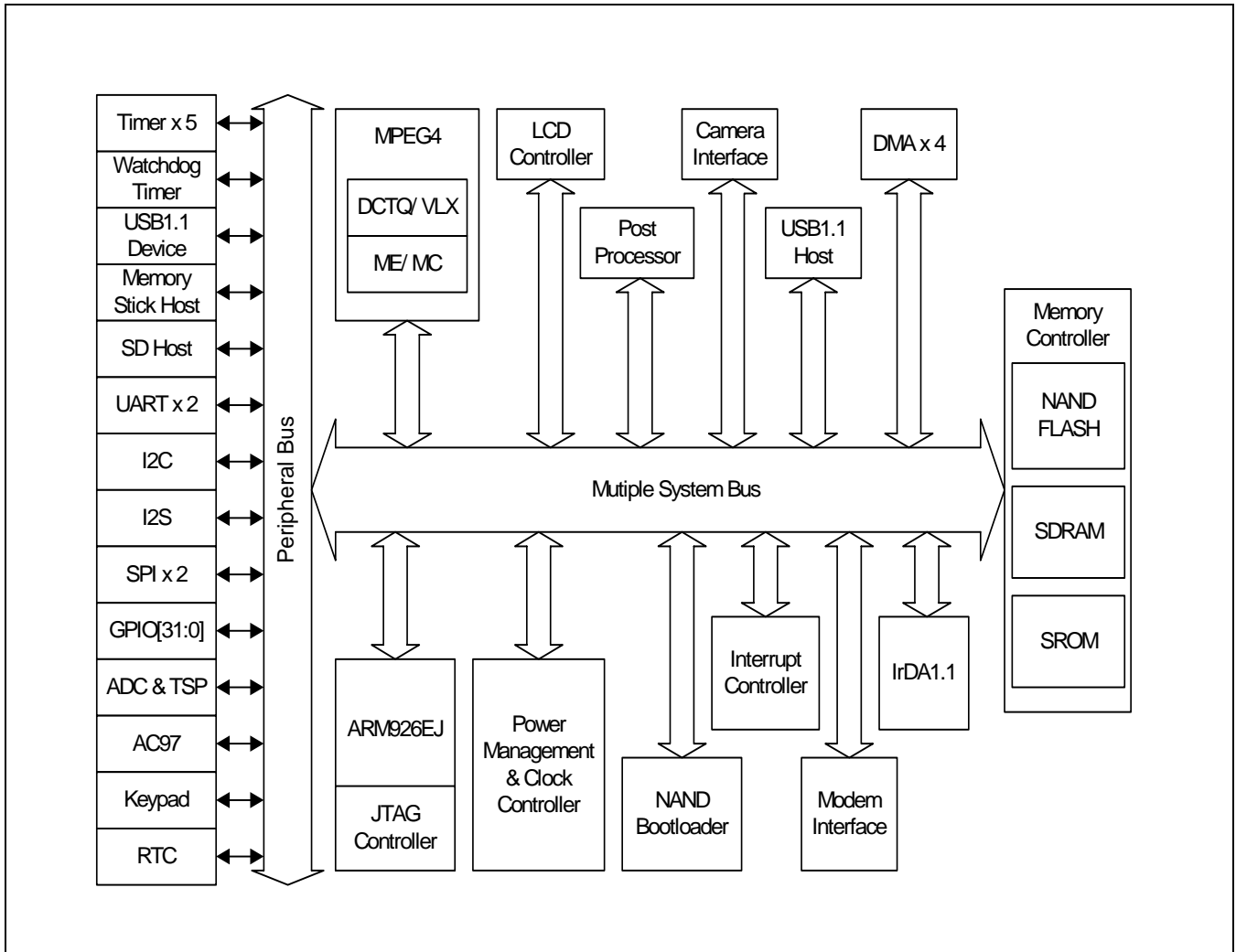

Figure 1-1. An Overall Block Diagram of the S3C24A0A

PIN ASSIGNMENT

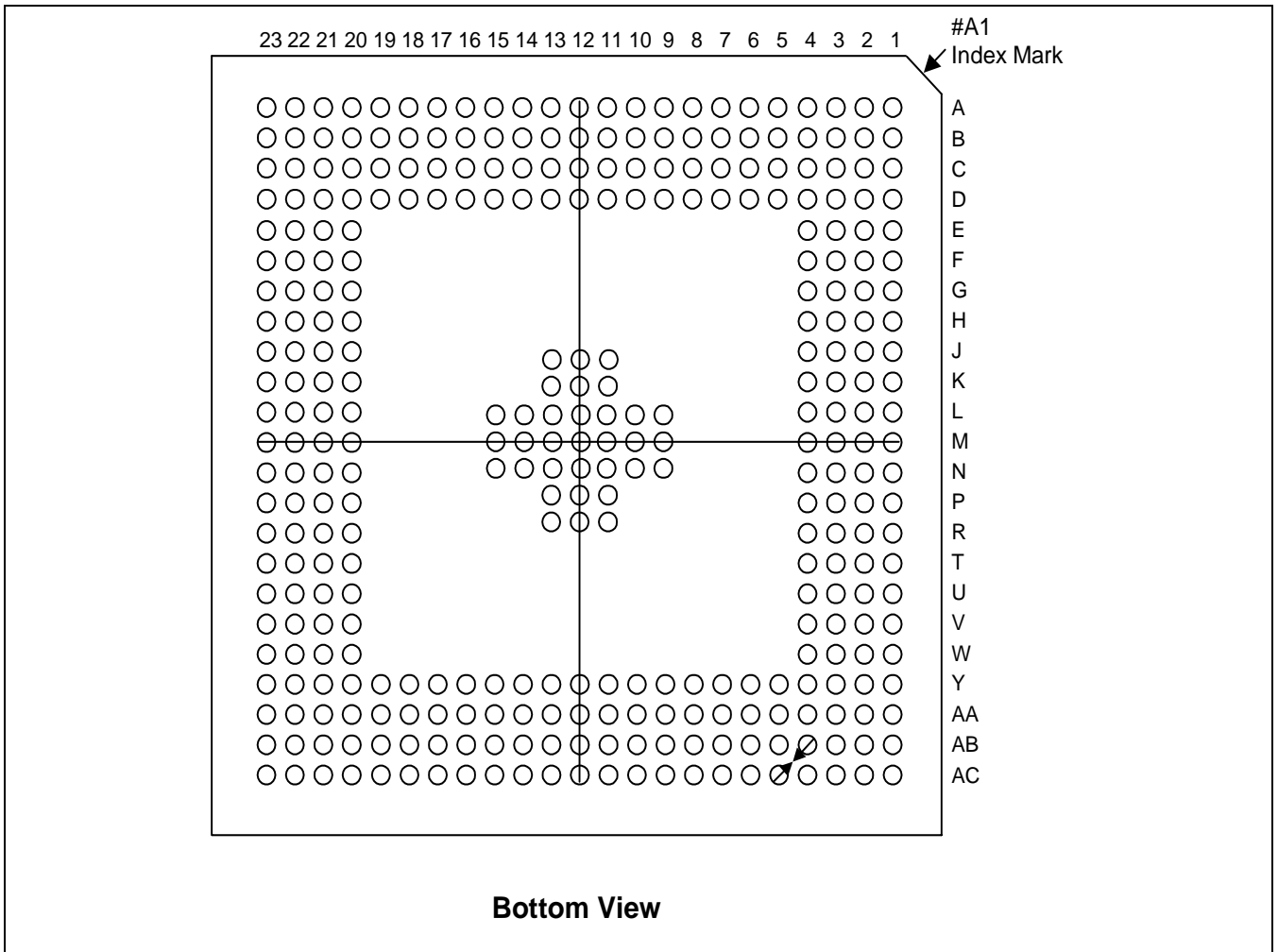

Figure 1-2. 337-Pin FBGA Pin Assignment

Table 1-1. 337-Pin FBGA Pin Assignments – Pin Number Order

Pin Number	Pin Name	Pin Number	Pin Name	Pin Number	Pin Name
A01	XCIYDATA[4]	B11	XRDATA[1]	C21	XRADDR [21]
A02	VSSpadIO	B12	XRDATA[3]	C22	XFNFPS
A03	XCICDATA[0]	B13	XRDATA[7]	C23	XFNFADV
A04	XCIYDATA[7]	B14	XRADDR[5]	D01	XJTDO
A05	XCIPCLK	B15	XRNWBE[0]	D02	XJTDI
A06	XVVD[5]	B16	XRWEN	D03	XVVD[2]
A07	XVVD[7]	B17	XRCSN[2]	D04	XCIRSTN
A08	XVCLK	B18	XRDATA[14]	D05	XCIYDATA[5]
A09	XVDEN	B19	XRADDR[11]	D06	XCIVSYNC
A10	XCICDATA[7]	B20	XRADDR[15]	D07	XVVD[13]
A11	XRDATA[0]	B21	XRADDR[22]	D08	XVVD[14]
A12	XRDATA[5]	B22	XFALE	D09	XCICDATA[5]
A13	XRADDR [3]	B23	XFNFACYC	D10	XJRTCK
A14	XRADDR [7]	C01	XJTMS	D11	XVVSUNC
A15	XRNWBE[1]	C02	XJTRSTN	D12	XVVD[19]
A16	XRDATA[8]	C03	XCICLK	D13	XVVD[22]
A17	XRDATA[13]	C04	XCICDATA[1]	D14	XRADDR [4]
A18	XRADDR [10]	C05	XVVD[4]	D15	XRADDR [2]
A19	XRADDR [16]	C06	XCIHREF	D16	XRADDR [0]
A20	XRADDR [17]	C07	XCICDATA[4]	D17	XRADDR [14]
A21	XRADDR[20]	C08	XCICDATA[6]	D18	XRADDR [19]
A22	XRADDR [23]	C09	XVHSUNC	D19	XFCLE
A23	XFRNB[0]	C10	XVVD[20]	D20	XRADDR [8]
B01	XJTCK	C11	XVVD[23]	D21	XRADDR [12]
B02	XCIYDATA[0]	C12	VDDarm	D22	XFNFBW
B03	XCIYDATA[2]	C13	XRDATA[6]	D23	XRADDR [25]
B04	XCIYDATA[6]	C14	XRADDR[1]	E01	XGPIO[31]
B05	XCICDATA[2]	C15	XRADDR [6]	E02	X2CSDA
B06	XCICDATA[3]	C16	XRWAITN	E03	X2CSCL
B07	XVVD[11]	C17	XRCSN[1]	E04	XCIYDATA[1]
B08	XVVD[15]	C18	XRDATA[10]	E20	XFRNB[1]
B09	XVVD[18]	C19	XRDATA[12]	E21	XRADDR [24]
B10	XVVD[21]	C20	XRADDR [9]	E22	XPDATA[2]



Table 1-1. 337-Pin FBGA Pin Assignments – Pin Number Order (Continued)

Pin Number	Pin Name	Pin Number	Pin Name	Pin Number	Pin Name
E23	XPDATA[1]	J21	VDDlogic	M09	VSSpadIO
F01	XGPIO[28]	J22	XPDQM[3]	M10	VDDalive
F02	XGPIO[29]	J23	XPDATA[8]	M11	VSS
F03	XGPIO[30]	K01	XGPIO[11]	M12	VSS
F04	XCIYDATA[3]	K02	XGPIO[14]	M13	VSS
F20	XRADDR [18]	K03	XGPIO[16]	M14	VDDlogic
F21	XPDATA[0]	K04	XVVD[12]	M15	VSSpadSDRAM
F22	XPDATA[6]	K11	VDDpadIO	M20	XPADDR[2]
F23	XPDATA[3]	K12	VSS	M21	XPDATA[15]
G01	XGPIO[24]	K13	VSSpadFlash	M22	XPADDR[1]
G02	XGPIO[26]	K20	XRDATA[11]	M23	XPADDR[3]
G03	XGPIO[27]	K21	XPDATA[9]	N01	X97SYNC
G04	XVVD[3]	K22	XPDATA[10]	N02	X97RESETN
G20	XRADDR [13]	K23	XPDATA[11]	N03	XGPIO[4]
G21	XPDATA[5]	L01	XGPIO[7]	N04	XGPIO[8]
G22	XPDQM[0]	L02	XGPIO[10]	N09	VDDlogic
G23	XPDATA[7]	L03	XGPIO[12]	N10	VDDpadIO
H01	XGPIO[20]	L04	XGPIO[21]	N11	VSS
H02	XGPIO[23]	L09	VDDarm	N12	VSS
H03	XGPIO[22]	L10	VDDarm	N13	VSS
H04	XVVD[6]	L11	VSS	N14	VSSpadSDRAM
H20	XPDATA[4]	L12	VSS	N15	VDDpadSDRAM
H21	VDDpadSDRAM	L13	VSS	N20	XRDATA[9]
H22	XPDQM[1]	L14	VDDpadFlash	N21	XPADDR[4]
H23	XPDQM[2]	L15	VSSpadSDRAM	N22	XPADDR[5]
J01	XGPIO[17]	L20	XPDATA[14]	N23	XPADDR[6]
J02	XGPIO[18]	L21	XPDATA[12]	P01	XURTSN
J03	XGPIO[25]	L22	XPDATA[13]	P02	X97SDO
J04	XVVD[10]	L23	XPADDR[0]	P03	X97BITCLK
J11	VSSpadIO	M01	XGPIO[0]	P04	XGPIO[5]
J12	VSSpadFlash	M02	XGPIO[6]	P11	VSSpadIO
J13	VDDpadFlash	M03	VDDpadIO	P12	VDDalive

Table 1-1. 337-Pin FBGA Pin Assignments – Pin Number Order (Continued)

Pin Number	Pin Name	Pin Number	Pin Name	Pin Number	Pin Name
J20	XRDATA[15]	M04	XGPIO[19]	P13	VSSpadSDRAM
P20	XRCSN[0]	V03	XGTMODE[3]	Y20	VDDpadSDRAM
P21	XPDATA[16]	V04	XUCLK	Y21	XPDATA[25]
P22	XPADDR[7]	V20	XRDATA[2]	Y22	XPDATA[27]
P23	XPDATA[18]	V21	XPDATA[29]	Y23	XPDATA[26]
R01	XGTMODE[2]	V22	XPWEN	AA01	XRTCXTI
R02	XURXD	V23	XPCASN	AA02	XGREFCLKSEL[0]
R03	XGPIO[2]	W01	XGTMODE[1]	AA03	XGPWROFFN
R04	XGPIO[15]	W02	XSPIMISO	AA04	XADCAIN[5]
R11	VDDlogic	W03	XSPISSIN[0]	AA05	XADCAVREF
R12	VDDpadModem	W04	X2SCLK	AA06	XADCAIN[2]
R13	VSSpadSDRAM	W20	VDDpadSDRAM	AA07	VSSadc
R20	XROEN	W21	VDDlogic	AA08	VDDMpll
R21	XPDATA[17]	W22	XPCSN[0]	AA09	XSRESETN
R22	XPDATA[19]	W23	XPCSN[1]	AA10	XSXTOUT
R23	XPCLK	Y01	XSWRESETN	AA11	XUSDP[0]
T01	X2SCDCLK	Y02	XGTMODE[0]	AA12	XUSDN[0]
T02	XUCTSN	Y03	XSPICLK	AA13	XMSBS
T03	X97SDI	Y04	X2SDI	AA14	XMIWEN
T04	XGPIO[13]	Y05	XGBATFLTN	AA15	XMIADR[8]
T20	XPDATA[24]	Y06	XGPIO[1]	AA16	XMIADR[6]
T21	XPDATA[20]	Y07	XGPIO[3]	AA17	XMIDATA[6]
T22	XPDATA[21]	Y08	VDD15	AA18	VDDlogic
T23	XPDATA[23]	Y09	XSRSTOUTN	AA19	XMIDATA[2]
U01	X2SDO	Y10	XUDDP	AA20	XMIADR[0]
U02	X2SLRCK	Y11	XSDDAT[3]	AA21	VDDpadSDRAM
U03	XUTXD	Y12	VDD20(VDDpadUSB)	AA22	XPDATA[31]
U04	XGPIO[9]	Y13	XMSSDIO	AA23	XPDATA[28]
U20	XRDATA[4]	Y14	XMSPi	AB01	VDDrtc
U21	XPDATA[22]	Y15	XMICSN	AB02	XADCAIN[7]
U22	XPCKE	Y16	XMIADR[10]	AB03	XRTCXTO
U23	XPRASN	Y17	XPADDR[13]	AB04	XGREFCLKSEL[1]

Table 1-1. 337-Pin FBGA Pin Assignments – Pin Number Order (Continued)

Pin Number	Pin Name	Pin Number	Pin Name	Pin Number	Pin Name
V01	XSPIMOSI	Y18	XMIADR[4]	AB05	XADCAIN[0]
V02	XSPISSIN[1]	Y19	XMIADR[2]	AB06	VDDadc
AB07	VSSMpll	AB21	XPADDR[11]	AC12	XSDDAT[2]
AB08	XSUPLLCAP	AB22	XPDATA[30]	AC13	XSDDAT[0]
AB09	XSEXTCLK	AB23	XPADDR[8]	AC14	XMIADR[9]
AB10	XUSDP[1]	AC01	VSSrtc	AC15	XMIADR[5]
AB11	XUDDN	AC02	XADCAIN[6]	AC16	XMIDATA[5]
AB12	XSDDAT[1]	AC03	XADCAIN[4]	AC17	XMIDATA[3]
AB13	VSSpadUSB	AC04	XADCAIN[3]	AC18	XMIDATA[1]
AB14	XMIOEN	AC05	XADCAIN[1]	AC19	XMIADR[3]
AB15	XMIADR[7]	AC06	XSMPLLCAP	AC20	XPADDR[14]
AB16	XMIDATA[7]	AC07	VSSUpll	AC21	XPADDR[12]
AB17	XMIDATA[4]	AC08	XGMONHCLK	AC22	XPADDR[10]
AB18	XMIIRQN	AC09	XSXTIN	AC23	XPADDR[9]
AB19	XMIDATA[0]	AC10	XUSDN[1]		
AB20	XMIADR[1]	AC11	XMSSCLKO		

Table 1-2. 337-Pin FBGA Pin Assignments

Pin Number	Name	Default Function	I/O	I/O state@ Reset mode (Data/En/PullupEn) En(L)=>output PullupEn(L)=>PullUp	I/O State@ SLEEP Mode	I/O State@ STOP Mode	Cell Type (S3C24A0A)
AA7	VSSadc	VSSadc	P	P	P	P	P
AB7	VSSMpll	VSSMpll	P	P	P	P	P
AC7	VSSUpII	VSSUpII	P	P	P	P	P
AB13	VSSpadUSB	VSSpadUSB	P	P	P	P	P
AC1	VSSrtc	VSSrtc	P	P	P	P	P
AA18	VDDlogic	VDDlogic	P	P	P	P	P
J21	VDDlogic	VDDlogic	P	P	P	P	P
M14	VDDlogic	VDDlogic	P	P	P	P	P
N9	VDDlogic	VDDlogic	P	P	P	P	P
R11	VDDlogic	VDDlogic	P	P	P	P	P
W21	VDDlogic	VDDlogic	P	P	P	P	P
K11	VDDpadIO	VDDpadIO	P	P	P	P	P
M3	VDDpadIO	VDDpadIO	P	P	P	P	P
N10	VDDpadIO	VDDpadIO	P	P	P	P	P
R12	VDDpadModem	VDDpadModem	P	P	P	P	P
C12	VDDarm	VDDarm	P	P	P	P	P
L10	VDDarm	VDDarm	P	P	P	P	P
L9	VDDarm	VDDarm	P	P	P	P	P
AA21	VDDpadSDRAM	VDDpadSDRAM	P	P	P	P	P
H21	VDDpadSDRAM	VDDpadSDRAM	P	P	P	P	P
N14	VSSpadSDRAM	VSSpadSDRAM	P	P	P	P	P
N15	VDDpadSDRAM	VDDpadSDRAM	P	P	P	P	P
W20	VDDpadSDRAM	VDDpadSDRAM	P	P	P	P	P
Y20	VDDpadSDRAM	VDDpadSDRAM	P	P	P	P	P
J13	VDDpadFlash	VDDpadFlash	P	P	P	P	P
L14	VDDpadFlash	VDDpadFlash	P	P	P	P	P
M10	VDDalive	VDDalive	P	P	P	P	P
P12	VDDalive	VDDalive	P	P	P	P	P
AB1	VDDrtc	VDDrtc	P	P	P	P	P
AB6	VDDadc	VDDadc	P	P	P	P	P
AA8	VDDMpll	VDDMpll	P	P	P	P	P
Y8	VDDupII	VDDupII	P	P	P	P	P

Table 1-2. 337-Pin FBGA Pin Assignments (Continued)

Pin Number	Name	Default Function	I/O	I/O state@ Reset mode (Data/En/PullupEn) En(L)=>output PullupEn(L)=>PullUp	I/O State@ SLEEP Mode	I/O State@ STOP Mode	Cell Type (S3C24A0A)
Y12	VDDpadUSB	VDDpadUSB	P	P	P	P	P
K12	VSS	VSS	P	P	P	P	P
L11	VSS	VSS	P	P	P	P	P
L12	VSS	VSS	P	P	P	P	P
L13	VSS	VSS	P	P	P	P	P
M11	VSS	VSS	P	P	P	P	P
M12	VSS	VSS	P	P	P	P	P
M13	VSS	VSS	P	P	P	P	P
N11	VSS	VSS	P	P	P	P	P
N12	VSS	VSS	P	P	P	P	P
N13	VSS	VSS	P	P	P	P	P
A2	VSSpadIO	VSSpadIO	P	P	P	P	P
J11	VSSpadIO	VSSpadIO	P	P	P	P	P
M9	VSSpadIO	VSSpadIO	P	P	P	P	P
P11	VSSpadIO	VSSpadIO	P	P	P	P	P
L15	VSSpadSDRAM	VSSpadSDRAM	P	P	P	P	P
M15	VSSpadSDRAM	VSSpadSDRAM	P	P	P	P	P
P13	VSSpadSDRAM	VSSpadSDRAM	P	P	P	P	P
R13	VSSpadSDRAM	VSSpadSDRAM	P	P	P	P	P
J12	VSSpadFlash	VSSpadFlash	P	P	P	P	P
K13	VSSpadFlash	VSSpadFlash	P	P	P	P	P
E3	X2cSCL	X2cSCL	I/O	I/H	L or I	H	phbsud8sm
E2	X2cSDA	X2cSDA	I/O	I/H	L or I	H	phbsud8sm
T1	X2sCDCLK	X2sCDCLK	O	H or L/L	Hi-z or H or L	H	phot8
W4	X2sCLK	X2sCLK	I/O	L/L/L	H or L or I	L	phbsu100ct8sm
Y4	X2sDI	X2sDI	I	I	–	–	phis
U1	X2sDO	X2sDO	O	L/L	Hi-z or H or L	L	phot8
U2	X2sLRCK	X2sLRCK	I/O	H/L/L	H or L or I	Pre	phbsu100ct8sm
P3	X97BITCLK	X97BITCLK	I	I	–	–	phis

Table 1-2. 337-Pin FBGA Pin Assignments (Continued)

Pin Number	Name	Default Function	I/O	I/O state@ Reset mode (Data/En/PullupEn) En(L)=>output PullupEn(L)=>PullUp	I/O State@ SLEEP Mode	I/O State@ STOP Mode	Cell Type (S3C24A0A)
N2	X97RESETn	X97RESETn	O	L/L	Hi-z or H or L	H	phot8
T3	X97SDI	X97SDI	I	I	–	–	phis
P2	X97SDO	X97SDO	O	L/L	Hi-z or H or L	L	phot8
N1	X97SYNC	X97SYNC	O	L/L	Hi-z or H or L	L	phot8
AB5	XadcAIN[0]	XadcAIN[0]	Ain	I	–	–	phiar10 _abb
AC5	XadcAIN[1]	XadcAIN[1]	Ain	I	–	–	phiar10 _abb
AA6	XadcAIN[2]	XadcAIN[2]	Ain	I	–	–	phiar10 _abb

Table 1-2. 337-Pin FBGA Pin Assignments (Continued)

Pin Number	Name	Default Function	I/O	I/O state@ Reset mode (Data/En/PullupEn) En(L)=>output PullupEn(L)=>PullUp	I/O State@ SLEEP Mode	I/O State@ STOP Mode	Cell Type (S3C24A0A)
AC4	XadcAIN[3]	XadcAIN[3]	Ain	I	–	–	phiar10_abb
AC3	XadcAIN[4]	XadcAIN[4]	Ain	I	–	–	phiar10_abb
AA4	XadcAIN[5]	XadcAIN[5]	Ain	I	–	–	phiar10_abb
AC2	XadcAIN[6]	XadcAIN[6]	Ain	I	–	–	phiar10_abb
AB2	XadcAIN[7]	XadcAIN[7]	Ain	I	–	–	phiar10_abb
AA5	XadcAVREF	XadcAVREF	Ain	I	–	–	phia_abb
A3	XciCDATA[0]	XciCDATA[0]	I	I/H/L	–	–	phbsu100ct8sm
C4	XciCDATA[1]	XciCDATA[1]	I	I/H/L	–	–	phbsu100ct8sm
B5	XciCDATA[2]	XciCDATA[2]	I	I/H/L	–	–	phbsu100ct8sm
B6	XciCDATA[3]	XciCDATA[3]	I	I/H/L	–	–	phbsu100ct8sm
C7	XciCDATA[4]	XciCDATA[4]	I	I/H/L	–	–	phbsu100ct8sm
D9	XciCDATA[5]	XciCDATA[5]	I	I/H/L	–	–	phbsu100ct8sm
C8	XciCDATA[6]	XciCDATA[6]	I	I/H/L	–	–	phbsu100ct8sm
A10	XciCDATA[7]	XciCDATA[7]	I	I/H/L	–	–	phbsu100ct8sm
C3	XciCLK	XciCLK	O	L/L	Hi-z or H or L	L	phot12sm
C6	XciHREF	XciHREF	I	I	–	–	phis
A5	XciPCLK	XciPCLK	I	I	–	–	phis
D4	XciRSTn	XciRSTn	O	L/L	Hi-z or H or L	Pre	phot8
D6	XciVSYNC	XciVSYNC	I	I	–	–	phis
B2	XciYDATA[0]	XciYDATA[0]	I	I	–	–	phis
E4	XciYDATA[1]	XciYDATA[1]	I	I	–	–	phis
B3	XciYDATA[2]	XciYDATA[2]	I	I	–	–	phis
F4	XciYDATA[3]	XciYDATA[3]	I	I	–	–	phis
A1	XciYDATA[4]	XciYDATA[4]	I	I	–	–	phis
D5	XciYDATA[5]	XciYDATA[5]	I	I	–	–	phis
B4	XciYDATA[6]	XciYDATA[6]	I	I	–	–	phis
A4	XciYDATA[7]	XciYDATA[7]	I	I	–	–	phis
B22	XfALE	XfALE	O	L/L	Hi-z or H or L	L	phot8
D19	XfCLE	XfCLE	O	L/L	Hi-z or H or L	L	phot8

Table 1-2. 337-Pin FBGA Pin Assignments (Continued)

Pin Number	Name	Default Function	I/O	I/O state@ Reset mode (Data/En/ PullupEn) En(L)=>output PullupEn(L)=>PullUp	I/O State@ SLEEP Mode	I/O State@ STOP Mode	Cell Type (S3C24A0A)
B23	XfNFACYC	XfNFACYC	I	I	–	–	phis
C23	XfNFADV	XfNFADV	I	I	–	–	phis
D22	XfNFBW	XfNFBW	I	I	–	–	phis
C22	XfNFPS	XfNFPS	I	I	–	–	phis
A23	XfRnB[0]	XfRnB[0]	I	I	–	–	phisu
E20	XfRnB[1]	XfRnB[1]	I	I	–	–	phisu
Y5	XgBATFLT	XgBATFLT	I	H	–	–	phis
AC8	XgMONHCLK	XgMONHCLK	O	L/L	Hi-z or H or L	L	phot8
M1	XgpIO[0]/EINT0	XgpIO[0]	I/O	I/H/L	H or L or I	–	phbsu100ct8sm
Y6	XgpIO[1]/EINT1/ PWM_ECLK	XgpIO[1]	I/O	I/H/L	H or L or I	–	phbsu100ct8sm
L2	XgpIO[10]/YMON	XgpIO[10]	I/O	I/H/L	H or L or I	–	phbsu100ct8sm
K1	XgpIO[11]/EINT11 /YPON	XgpIO[11]	I/O	I/H/L	H or L or I	–	phbsu100ct8sm
L3	XgpIO[12]/EINT12/ XMON	XgpIO[12]	I/O	I/H/L	H or L or I	–	phbsu100ct8sm
T4	XgpIO[13]/EINT13/ XPON	XgpIO[13]	I/O	I/H/L	H or L or I	–	phbsu100ct8sm
K2	XgpIO[14]/EINT14/ RTC_ALMINT	XgpIO[14]	I/O	I/H/L	H or L or I	–	phbsu100ct8sm
R4	XgpIO[15]/EINT15/ XspiMOSI	XgpIO[15]	I/O	I/H/L	H or L or I	–	phbsu100ct8sm
K3	XgpIO[16]/EINT16/ XspiMISO	XgpIO[16]	I/O	I/H/L	H or L or I	–	phbsu100ct8sm
J1	XgpIO[17]/EINT17/ XspiCLK	XgpIO[17]	I/O	I/H/L	H or L or I	–	phbsu100ct8sm
J2	XgpIO[18]/EINT18/ XkpROW0	XgpIO[18]	I/O	I/H/L	H or L or I	–	phbsu100ct8sm
M4	XgpIO[19]/PWM_ ECLK/XkpROW1	XgpIO[19]	I/O	I/H/L	H or L or I	–	phbsu100ct8sm
R3	XgpIO[2]/EINT2/ PWM_TOUT0	XgpIO[2]	I/O	I/H/L	H or L or I	–	phbsu100ct8sm
H1	XgpIO[20]/PWM_ TOUT0/ XkpROW2	XgpIO[20]	I/O	I/H/L	H or L or I	–	phbsu100ct8sm



Table 1-2. 337-Pin FBGA Pin Assignments (Continued)

Pin Number	Name	Default Function	I/O	I/O state@ Reset mode (Data/En/PullupEn) En(L)=>output PullupEn(L)=> PullUp	I/O State@ SLEEP Mode	I/O State@ STOP Mode	Cell Type (S3C24A0A)
L4	XgpIO[21]/PWM_TO UT1/XkpROW3	XgpIO[21]	I/O	I/H/L	H or L or I	–	phbsu100ct8sm
H3	XgpIO[22]/PWM_TO UT2/XkpROW4	XgpIO[22]	I/O	I/H/L	H or L or I	–	phbsu100ct8sm
H2	XgpIO[23]/PWM_TO UT3/XkpCOL0	XgpIO[23]	I/O	I/H/L	H or L or I	–	phbsu100ct8sm
G1	XgpIO[24]/EXTDMA_REQ0/XkpCOL1	XgpIO[24]	I/O	I/H/L	H or L or I	–	phbsu100ct8sm
J3	XgpIO[25]/EXTDMA_REQ1/XkpCOL2	XgpIO[25]	I/O	I/H/L	H or L or I	–	phbsu100ct8sm
G2	XgpIO[26]/EXTDMA_ACK0/XkpCOL3	XgpIO[26]	I/O	I/H/L	H or L or I	–	phbsu100ct8sm
G3	XgpIO[27]/EXTDMA_ACK1/XkpCOL4	XgpIO[27]	I/O	I/H/L	H or L or I	–	phbsu100ct8sm
F1	XgpIO[28]/XuCTSn1/RTC_ALMINT	XgpIO[28]	I/O	I/H/L	H or L or I	–	phbsu100ct8sm
F2	XgpIO[29]/XuRTSn1/IrDA_SDBW	XgpIO[29]	I/O	I/H/L	H or L or I	–	phbsu100ct8sm
Y7	XgpIO[3]/EINT3/PWM_TOUT1	XgpIO[3]	I/O	I/H/L	H or L or I	–	phbsu100ct8sm
F3	XgpIO[30]/XuTXD1/IrDA_TXD	XgpIO[30]	I/O	I/H/L	H or L or I	–	phbsu100ct8sm
E1	XgpIO[31]/XuRXD1/IrDA_RXD	XgpIO[31]	I/O	I/H/L	H or L or I	–	phbsu100ct8sm
N3	XgpIO[4]/EINT4/PWM_TOUT2	XgpIO[4]	I/O	I/H/L	H or L or I	–	phbsu100ct8sm
P4	XgpIO[5]/EINT5/PWM_TOUT3	XgpIO[5]	I/O	I/H/L	H or L or I	–	phbsu100ct8sm
M2	XgpIO[6]/EINT6	XgpIO[6]	I/O	I/H/L	H or L or I	–	phbsu100ct8sm
L1	XgpIO[7]/EINT7	XgpIO[7]	I/O	I/H/L	H or L or I	–	phbsu100ct8sm
N4	XgpIO[8]/EINT8	XgpIO[8]	I/O	I/H/L	H or L or I	–	phbsu100ct8sm
U4	XgpIO[9]/EINT9	XgpIO[9]	I/O	I/H/L	H or L or I	–	phbsu100ct8sm
AA3	XgPWROFFn	XgPWROFFn	O	H	L	H	phob8

Table 1-2. 337-Pin FBGA Pin Assignments (Continued)

Pin Number	Name	Default Function	I/O	I/O state@ Reset mode (Data/En/PullupEn) En(L)=>output PullupEn(L)=>PullUp	I/O State@ SLEEP Mode	I/O State@ STOP Mode	Cell Type (S3C24A0A)
AA2	XgREFCLKSEL[0]	XgREFCLKSEL[0]	I	H	–	–	phis
AB4	XgREFCLKSEL[1]	XgREFCLKSEL[1]	I	H	–	–	phis
Y2	XgTMODE[0]	XgTMODE[0]	I	I	–	–	phis
W1	XgTMODE[1]	XgTMODE[1]	I	I	–	–	phis
R1	XgTMODE[2]	XgTMODE[2]	I	I	–	–	phis
V3	XgTMODE[3]	XgTMODE[3]	I	I	–	–	phis
D10	XjRTCK	XjRTCK	O	L	–	–	phob8
B1	XjTCK	XjTCK	I	I	–	–	phis
D2	XjTDI	XjTDI	I	I	–	–	phisu
D1	XjTDO	XjTDO	O	I/H	Hi-z or H or L	Hi-z	phot8
C1	XjTMS	XjTMS	I	I	–	–	phisu
C2	XjTRSTn	XjTRSTn	I	I	–	–	phisu
AA20	XmiADR[0]	XmiADR[0]	I	I/H/L	–	–	phbsu100ct8sm
AB20	XmiADR[1]	XmiADR[1]	I	I/H/L	–	–	phbsu100ct8sm
Y16	XmiADR[10]	XmiADR[10]	I	I/H/L	–	–	phbsu100ct8sm
Y19	XmiADR[2]	XmiADR[2]	I	I/H/L	–	–	phbsu100ct8sm
AC19	XmiADR[3]	XmiADR[3]	I	I/H/L	–	–	phbsu100ct8sm
Y18	XmiADR[4]	XmiADR[4]	I	I/H/L	–	–	phbsu100ct8sm
AC15	XmiADR[5]	XmiADR[5]	I	I/H/L	–	–	phbsu100ct8sm
AA16	XmiADR[6]	XmiADR[6]	I	I/H/L	–	–	phbsu100ct8sm
AB15	XmiADR[7]	XmiADR[7]	I	I/H/L	–	–	phbsu100ct8sm
AA15	XmiADR[8]	XmiADR[8]	I	I/H/L	–	–	phbsu100ct8sm
AC14	XmiADR[9]	XmiADR[9]	I	I/H/L	–	–	phbsu100ct8sm
Y15	XmiCSn	XmiCSn	I	I	–	–	phisu
AB19	XmiDATA[0]	XmiDATA[0]	I/O	I/H/L	H or L or I	–	phbsu100ct8sm
AC18	XmiDATA[1]	XmiDATA[1]	I/O	I/H/L	H or L or I	–	phbsu100ct8sm
AA19	XmiDATA[2]	XmiDATA[2]	I/O	I/H/L	H or L or I	–	phbsu100ct8sm
AC17	XmiDATA[3]	XmiDATA[3]	I/O	I/H/L	H or L or I	–	phbsu100ct8sm
AB17	XmiDATA[4]	XmiDATA[4]	I/O	I/H/L	H or L or I	–	phbsu100ct8sm
AC16	XmiDATA[5]	XmiDATA[5]	I/O	I/H/L	H or L or I	–	phbsu100ct8sm
AA17	XmiDATA[6]	XmiDATA[6]	I/O	I/H/L	H or L or I	–	phbsu100ct8sm
AB16	XmiDATA[7]	XmiDATA[7]	I/O	I/H/L	H or L or I	–	phbsu100ct8sm

Table 1-2. 337-Pin FBGA Pin Assignments (Continued)

Pin Number	Name	Default Function	I/O	I/O state@ Reset mode (Data/En/PullupEn) En(L)=>output PullupEn(L)=>PullUp	I/O State@ SLEEP Mode	I/O State@ STOP Mode	Cell Type (S3C24A0A)
AB18	XmiIRQn	XmiIRQn	O	H/L	Hi-z or H or L	H	phot8
AB14	XmiOEn	XmiOEn	I	I	–	–	phisu
AA14	XmiWEn	XmiWEn	I	I	–	–	phisu
AA13	XmsBS	XmsBS	O	L/L	Hi-z or H or L	L	phot8
Y14	XmsPI	XmsPI	I	I	–	–	phis
AC11	XmsSCLKO	XmsSCLKO	O	H/L	Hi-z or H or L	H	phot8
Y13	XmsSDIO	XmsSDIO	I/O	I/H/L	H or L or I	–	phbsu100ct12sm
L23	XpADDR[0]	XpADDR[0]	O	L/L	Hi-z or H or L	Pre	phot12sm
M22	XpADDR[1]	XpADDR[1]	O	L/L	Hi-z or H or L	Pre	phot12sm
AC22	XpADDR[10]	XpADDR[10]	O	L/L	Hi-z or H or L	Pre	phot12sm
AB21	XpADDR[11]	XpADDR[11]	O	L/L	Hi-z or H or L	Pre	phot12sm
AC21	XpADDR[12]	XpADDR[12]	O	L/L	Hi-z or H or L	Pre	phot12sm
Y17	XpADDR[13]	XpADDR[13]	O	L/L	Hi-z or H or L	Pre	phot12sm
AC20	XpADDR[14]	XpADDR[14]	O	L/L	Hi-z or H or L	Pre	phot12sm
M20	XpADDR[2]	XpADDR[2]	O	L/L	Hi-z or H or L	Pre	phot12sm
M23	XpADDR[3]	XpADDR[3]	O	L/L	Hi-z or H or L	Pre	phot12sm
N21	XpADDR[4]	XpADDR[4]	O	L/L	Hi-z or H or L	Pre	phot12sm
N22	XpADDR[5]	XpADDR[5]	O	L/L	Hi-z or H or L	Pre	phot12sm
N23	XpADDR[6]	XpADDR[6]	O	L/L	Hi-z or H or L	Pre	phot12sm
P22	XpADDR[7]	XpADDR[7]	O	L/L	Hi-z or H or L	Pre	phot12sm
AB23	XpADDR[8]	XpADDR[8]	O	L/L	Hi-z or H or L	Pre	phot12sm
AC23	XpADDR[9]	XpADDR[9]	O	L/L	Hi-z or H or L	Pre	phot12sm
V23	XpCASn	XpCASn	O	H/L	Hi-z or H or L	Pre	phot12sm
U22	XpCKE	XpCKE	O	L/L	Hi-z or H or L	L	phot12sm

Table 1-2. 337-Pin FBGA Pin Assignments (Continued)

Pin Number	Name	Default Function	I/O	I/O state@ Reset mode (Data/En/PullupEn) En(L)=>output PullupEn(L)=>PullUp	I/O State@ SLEEP Mode	I/O State@ STOP Mode	Cell Type (S3C24A0A)
W22	XpCSN[0]	XpCSN[0]	O	H/L	Hi-z or H or L	H	phot12sm
W23	XpCSN[1]	XpCSN[1]	O	H/L	Hi-z or H or L	H	phot12sm
F21	XpDATA[0]	XpDATA[0]	I/O	I/H/L	H or L or I	–	phbsu100ct12sm
E23	XpDATA[1]	XpDATA[1]	I/O	I/H/L	H or L or I	–	phbsu100ct12sm
K22	XpDATA[10]	XpDATA[10]	I/O	I/H/L	H or L or I	–	phbsu100ct12sm
K23	XpDATA[11]	XpDATA[11]	I/O	I/H/L	H or L or I	–	phbsu100ct12sm
L21	XpDATA[12]	XpDATA[12]	I/O	I/H/L	H or L or I	–	phbsu100ct12sm
L22	XpDATA[13]	XpDATA[13]	I/O	I/H/L	H or L or I	–	phbsu100ct12sm
L20	XpDATA[14]	XpDATA[14]	I/O	I/H/L	H or L or I	–	phbsu100ct12sm
M21	XpDATA[15]	XpDATA[15]	I/O	I/H/L	H or L or I	–	phbsu100ct12sm
P21	XpDATA[16]	XpDATA[16]	I/O	I/H/L	H or L or I	–	phbsu100ct12sm
R21	XpDATA[17]	XpDATA[17]	I/O	I/H/L	H or L or I	–	phbsu100ct12sm
P23	XpDATA[18]	XpDATA[18]	I/O	I/H/L	H or L or I	–	phbsu100ct12sm
R22	XpDATA[19]	XpDATA[19]	I/O	I/H/L	H or L or I	–	phbsu100ct12sm
E22	XpDATA[2]	XpDATA[2]	I/O	I/H/L	H or L or I	–	phbsu100ct12sm
T21	XpDATA[20]	XpDATA[20]	I/O	I/H/L	H or L or I	–	phbsu100ct12sm
T22	XpDATA[21]	XpDATA[21]	I/O	I/H/L	H or L or I	–	phbsu100ct12sm
U21	XpDATA[22]	XpDATA[22]	I/O	I/H/L	H or L or I	–	phbsu100ct12sm
T23	XpDATA[23]	XpDATA[23]	I/O	I/H/L	H or L or I	–	phbsu100ct12sm
T20	XpDATA[24]	XpDATA[24]	I/O	I/H/L	H or L or I	–	phbsu100ct12sm
Y21	XpDATA[25]	XpDATA[25]	I/O	I/H/L	H or L or I	–	phbsu100ct12sm
Y23	XpDATA[26]	XpDATA[26]	I/O	I/H/L	H or L or I	–	phbsu100ct12sm
Y22	XpDATA[27]	XpDATA[27]	I/O	I/H/L	H or L or I	–	phbsu100ct12sm

Table 1-2. 337-Pin FBGA Pin Assignments (Continued)

Pin Number	Name	Default Function	I/O	I/O state@ Reset mode (Data/En/PullupEn) En(L)=>output PullupEn(L)=>PullUp	I/O State@ SLEEP Mode	I/O State@ STOP Mode	Cell Type (S3C24A0A)
AA23	XpDATA[28]	XpDATA[28]	I/O	I/H/L	H or L or I	–	phbsu100ct12sm
V21	XpDATA[29]	XpDATA[29]	I/O	I/H/L	H or L or I	–	phbsu100ct12sm
F23	XpDATA[3]	XpDATA[3]	I/O	I/H/L	H or L or I	–	phbsu100ct12sm
AB22	XpDATA[30]	XpDATA[30]	I/O	I/H/L	H or L or I	–	phbsu100ct12sm
AA22	XpDATA[31]	XpDATA[31]	I/O	I/H/L	H or L or I	–	phbsu100ct12sm
H20	XpDATA[4]	XpDATA[4]	I/O	I/H/L	H or L or I	–	phbsu100ct12sm
G21	XpDATA[5]	XpDATA[5]	I/O	I/H/L	H or L or I	–	phbsu100ct12sm
F22	XpDATA[6]	XpDATA[6]	I/O	I/H/L	H or L or I	–	phbsu100ct12sm
G23	XpDATA[7]	XpDATA[7]	I/O	I/H/L	H or L or I	–	phbsu100ct12sm
J23	XpDATA[8]	XpDATA[8]	I/O	I/H/L	H or L or I	–	phbsu100ct12sm
K21	XpDATA[9]	XpDATA[9]	I/O	I/H/L	H or L or I	–	phbsu100ct12sm
G22	XpDQM[0]	XpDQM[0]	O	H/L	Hi-z or H or L	–	phot12sm
H22	XpDQM[1]	XpDQM[1]	O	H/L	Hi-z or H or L	–	phot12sm
H23	XpDQM[2]	XpDQM[2]	O	H/L	Hi-z or H or L	–	phot12sm
J22	XpDQM[3]	XpDQM[3]	O	H/L	Hi-z or H or L	–	phot12sm
U23	XpRASn	XpRASn	O	H/L	Hi-z or H or L	–	phot12sm
R23	XpSCLK	XpSCLK	I/O	H or L /L	H or L or I	L	phbst12sm
V22	XpWEn	XpWEn	O	H/L	Hi-z or H or L	H	phot12sm
D16	XrADDR[0]	XrADDR[0]	O	L/L	Hi-z or H or L	Pre	phot8
C14	XrADDR[1]	XrADDR[1]	O	L/L	Hi-z or H or L	Pre	phot8
A18	XrADDR[10]	XrADDR[10]	O	L/L	Hi-z or H or L	Pre	phot8
B19	XrADDR[11]	XrADDR[11]	O	L/L	Hi-z or H or L	Pre	phot8
D21	XrADDR[12]	XrADDR[12]	O	L/L	Hi-z or H or L	Pre	phot8

Table 1-2. 337-Pin FBGA Pin Assignments (Continued)

Pin Number	Name	Default Function	I/O	I/O state@ Reset mode (Data/En/PullupEn) En(L)=>output PullupEn(L)=>PullUp	I/O State@ SLEEP Mode	I/O State@ STOP Mode	Cell Type (S3C24A0A)
G20	XrADDR[13]	XrADDR[13]	O	L/L	Hi-z or H or L	Pre	phot8
D17	XrADDR[14]	XrADDR[14]	O	L/L	Hi-z or H or L	Pre	phot8
B20	XrADDR[15]	XrADDR[15]	O	L/L	Hi-z or H or L	Pre	phot8
A19	XrADDR[16]	XrADDR[16]	O	L/L	Hi-z or H or L	Pre	phot8
A20	XrADDR[17]	XrADDR[17]	O	L/L	Hi-z or H or L	Pre	phot8
D15	XrADDR[2]	XrADDR[2]	O	L/L	Hi-z or H or L	Pre	phot8
A13	XrADDR[3]	XrADDR[3]	O	L/L	Hi-z or H or L	Pre	phot8
D14	XrADDR[4]	XrADDR[4]	O	L/L	Hi-z or H or L	Pre	phot8
B14	XrADDR[5]	XrADDR[5]	O	L/L	Hi-z or H or L	Pre	phot8
C15	XrADDR[6]	XrADDR[6]	O	L/L	Hi-z or H or L	Pre	phot8
A14	XrADDR[7]	XrADDR[7]	O	L/L	Hi-z or H or L	Pre	phot8
D20	XrADDR[8]	XrADDR[8]	O	L/L	Hi-z or H or L	Pre	phot8
C20	XrADDR [9]	XrADDR [9]	O	L/L	Hi-z or H or L	Pre	phot8
F20	XrADDR[18]	XrADDR[18]	O	L/L/H	Hi-z or H or L	Pre	phbsu100ct8sm
D18	XrADDR[19]	XrADDR[19]	O	L/L/H	Hi-z or H or L	Pre	phbsu100ct8sm
A21	XrADDR[20]	XrADDR[20]	O	L/L/H	Hi-z or H or L	Pre	phbsu100ct8sm
C21	XrADDR[21]	XrADDR[21]	O	L/L/H	Hi-z or H or L	Pre	phbsu100ct8sm
B21	XrADDR[22]	XrADDR[22]	O	L/L/H	Hi-z or H or L	Pre	phbsu100ct8sm
A22	XrADDR[23]	XrADDR[23]	O	L/L/H	Hi-z or H or L	Pre	phbsu100ct8sm
E21	XrADDR[24]	XrADDR[24]	O	L/L/H	Hi-z or H or L	Pre	phbsu100ct8sm
D23	XrADDR[25]	XrADDR[25]	O	L/L/H	Hi-z or H or L	Pre	phbsu100ct8sm
P20	XrCSn[0]	XrCSn[0]	O	H/L	Hi-z or H or L	Pre	phot8

Table 1-2. 337-Pin FBGA Pin Assignments (Continued)

Pin Number	Name	Default Function	I/O	I/O state@ Reset mode (Data/En/PullupEn) En(L)=>output PullupEn(L)=>PullUp	I/O State@ SLEEP Mode	I/O State@ STOP Mode	Cell Type (S3C24A0A)
C17	XrCSn[1]	XrCSn[1]	O	H/L	Hi-z or H or L	Pre	phot8
B17	XrCSn[2]	XrCSn[2]	O	H/L	Hi-z or H or L	Pre	phot8
A11	XrDATA[0]	XrDATA[0]	I/O	I/H/L	H or L or I	–	phbsu100ct8sm
B11	XrDATA[1]	XrDATA[1]	I/O	I/H/L	H or L or I	–	phbsu100ct8sm
C18	XrDATA[10]	XrDATA[10]	I/O	I/H/L	H or L or I	–	phbsu100ct8sm
K20	XrDATA[11]	XrDATA[11]	I/O	I/H/L	H or L or I	–	phbsu100ct8sm
C19	XrDATA[12]	XrDATA[12]	I/O	I/H/L	H or L or I	–	phbsu100ct8sm
A17	XrDATA[13]	XrDATA[13]	I/O	I/H/L	H or L or I	–	phbsu100ct8sm
B18	XrDATA[14]	XrDATA[14]	I/O	I/H/L	H or L or I	–	phbsu100ct8sm
J20	XrDATA[15]	XrDATA[15]	I/O	I/H/L	H or L or I	–	phbsu100ct8sm
V20	XrDATA[2]	XrDATA[2]	I/O	I/H/L	H or L or I	–	phbsu100ct8sm
B12	XrDATA[3]	XrDATA[3]	I/O	I/H/L	H or L or I	–	phbsu100ct8sm
U20	XrDATA[4]	XrDATA[4]	I/O	I/H/L	H or L or I	–	phbsu100ct8sm
A12	XrDATA[5]	XrDATA[5]	I/O	I/H/L	H or L or I	–	phbsu100ct8sm
C13	XrDATA[6]	XrDATA[6]	I/O	I/H/L	H or L or I	–	phbsu100ct8sm
B13	XrDATA[7]	XrDATA[7]	I/O	I/H/L	H or L or I	–	phbsu100ct8sm
A16	XrDATA[8]	XrDATA[8]	I/O	I/H/L	H or L or I	–	phbsu100ct8sm
N20	XrDATA[9]	XrDATA[9]	I/O	I/H/L	H or L or I	–	phbsu100ct8sm
B15	XrnWBE[0]	XrnWBE[0]	O	H/L	Hi-z or H or L	Pre	phot8
A15	XrnWBE[1]	XrnWBE[1]	O	H/L	Hi-z or H or L	Pre	phot8
R20	XrOEn	XrOEn	O	H/L	Hi-z or H or L	H	phot8

Table 1-2. 337-Pin FBGA Pin Assignments (Continued)

Pin Number	Name	Default Function	I/O	I/O state@ Reset mode (Data/En/PullupEn) En(L)=>output PullupEn(L)=>PullUp	I/O State@ SLEEP Mode	I/O State@ STOP Mode	Cell Type (S3C24A0A)
AA1	XrtcXTI	XrtcXTI	Ain	L	–	–	rtc_osc
AB3	XrtcXTO	XrtcXTO	Aout	X	–	–	rtc_osc
C16	XrWAITn	XrWAITn	I	I	–	–	phis
B16	XrWEn	XrWEn	O	H/L	Hi-z or H or L	H	phot8
AC13	XsdDAT[0]	XsdDAT[0]	I/O	I/H/L	H or L or I	–	phbsu100ct12sm
AB12	XsdDAT[1]	XsdDAT[1]	I/O	I/H/L	H or L or I	–	phbsu100ct12sm
AC12	XsdDAT[2]	XsdDAT[2]	I/O	I/H/L	H or L or I	–	phbsu100ct12sm
Y11	XsdDAT[3]	XsdDAT[3]	I/O	I/H/L	H or L or I	–	phbsu100ct12sm
AB9	XsEXTCLK	XsEXTCLK	I	I	–	–	phis
AC6	XsMPLLCAP	XsMPLLCAP	Aout	X	–	–	Phoar50_abb
Y3	XspiCLK	XspiCLK	I/O	I/H/L	H or L or I	–	phtbsu100ct8sm
W2	XspiMISO	XspiMISO	I/O	H/L/L	H or L or I	H	phtbsu100ct8sm
V1	XspiMOSI	XspiMOSI	I/O	I/H/L	H or L or I	–	phtbsu100ct8sm
W3	XspiSSIn[0]	XspiSSIn[0]	I	I	–	–	phisu
V2	XspiSSIn[1]	XspiSSIn[1]	I	I	–	–	phisu
AA9	XsRESETn	XsRESETn	I	L	–	–	phisu
Y9	XsRSTOUTn	XsRSTOUTn	O	L	Hi-z or H or L	H	phot8
AB8	XsUPLLCAP	XsUPLLCAP	Aout	X	–	–	Phoar50_abb
Y1	XsWRESETn	XsWRESETn	I	L	–	–	phisu
AC9	XsXTIN	XsXTIN	I	H or L	–	–	phsoscsm26_schmitt
AA10	XsXTOUT	XsXTOUT	O	H or L	–	–	phsoscsm26_schmitt
V4	XuCLK	XuCLK	I	I	–	–	phis
T2	XuCTS <sub>n</sub>	XuCTS <sub>n</sub>	I	I	–	–	phis
AB11	XudDN	XudDN	I/O	I	H or L or I	–	pbusb1
Y10	XudDP	XudDP	I/O	I	H or L or I	–	pbusb1
P1	XuRTS <sub>n</sub>	XuRTS <sub>n</sub>	O	H/L	Hi-z or H or L	H	phot8
R2	XuRXD	XuRXD	I	I	–	–	phisu
AA12	XusDN[0]	XusDN[0]	I/O	X	H or L or I	–	pbusb1



Table 1-2. 337-Pin FBGA Pin Assignments (Continued)

Pin Number	Name	Default Function	I/O	I/O state@ Reset mode (Data/En/PullupEn) En(L)=>output PullupEn(L)=>PullUp	I/O State@ SLEEP Mode	I/O State@ STOP Mode	Cell Type (S3C24A0A)
AC10	XusDN[1]	XusDN[1]	I/O	X	H or L or I	–	pbusb1
AA11	XusDP[0]	XusDP[0]	I/O	X	H or L or I	–	pbusb1
AB10	XusDP[1]	XusDP[1]	I/O	X	H or L or I	–	pbusb1
U3	XuTXD	XuTXD	O	H/L	Hi-z or H or L	H	phot8
A9	XvDEN	XvDEN	O	L/L	Hi-z or H or L	L	phot8
C9	XvHSYNC	XvHSYNC	O	L/L	Hi-z or H or L	Pre	phot8
A8	XvVCLK	XvVCLK	O	H or L /L	Hi-z or H or L	L	phot12sm
J4	XvVD[6]	XvVD[6]	O	L/L	H or L or I	Pre	phot12sm
B7	XvVD[7]	XvVD[7]	O	L/L	H or L or I	Pre	phot12sm
K4	XvVD[8]	XvVD[8]	O	L/L	H or L or I	Pre	phot12sm
D7	XvVD[9]	XvVD[9]	O	L/L	H or L or I	Pre	phot12sm
D8	XvVD[10]	XvVD[10]	O	L/L	H or L or I	Pre	phot12sm
B8	XvVD[11]	XvVD[11]	O	L/L	H or L or I	Pre	phot12sm
B9	XvVD[12]	XvVD[12]	O	L/L	H or L or I	Pre	phot12sm
D12	XvVD[13]	XvVD[13]	O	L/L	H or L or I	Pre	phot12sm
D3	XvVD[0]	XvVD[0]	O	L/L	H or L or I	Pre	phot12sm
C10	XvVD[14]	XvVD[14]	O	L/L	H or L or I	Pre	phot12sm
B10	XvVD[15]	XvVD[15]	O	L/L	H or L or I	Pre	phot12sm
D13	XvVD[16]	XvVD[16]	O	L/L	H or L or I	Pre	phot12sm
C11	XvVD[17]	XvVD[17]	O	L/L	H or L or I	Pre	phot12sm
G4	XvVD[1]	XvVD[1]	O	L/L	H or L or I	Pre	phot12sm

Table 1-2. 337-Pin FBGA Pin Assignments (Continued)

Pin Number	Name	Default Function	I/O	I/O state@ Reset mode (Data/En/PullupEn) En(L)=>output PullupEn(L)=>PullUp	I/O State@ SLEEP Mode	I/O State@ STOP Mode	Cell Type (S3C24A0A)
C5	XvVD[2]	XvVD[2]	O	L/L	H or L or I	Pre	phot12sm
A6	XvVD[3]	XvVD[3]	O	L/L	H or L or I	Pre	phot12sm
H4	XvVD[4]	XvVD[4]	O	L/L	H or L or I	Pre	phot12sm
A7	XvVD[5]	XvVD[5]	O	L/L	H or L or I	Pre	phot12sm
D11	XvVSYNC	XvVSYNC	O	L/L	Hi-z or H or L	L	phot8

**NOTES:**

1. '-' mark indicates the unchanged pin state
2. Hi-z or Pre means Hi-z or Previous value
3. P, I and O mean power, input and output respectively
4. AI/AO means analog input/output

The table below shows I/O types and the descriptions.

I/O Type	Descriptions
vdd12ih	1.2V Vdd for alive
vdd12ih_core	1.2V Vdd for internal logic
vdd33oph	3.3V Vdd for external logic
vdd33th_abb	3.3V Vdd for analog circuit
vdd30th_rtc	3.3V Vdd for rtc circuit
vdd33th_abb	3.3V Vdd for pll circuit
Vss	Vss
Phis	Input pad, LVCMOS schmitt-trigger level
Phisu	Input pad, schmitt-trigger level, pull-up
Phisd	Input pad, schmitt-trigger level, pull-down
Pbusb	USB pad
phot8	Output pad, tri-state, lo=8mA
phob8	Output pad, lo=8mA
phot12sm	Output pad, tri-state, medium slew rate, lo=12mA
phbst12sm	Bi-directional pad, LVCMOS schmitt-trigger, pull-up resistor with control, tri-state, lo=12mA
pbusb1	USB pad
Rtc-osc	rtc X-tal
phob1-abb	Analog pad
phiar10_abb	Analog input pad with 10-ohm resistor
phia_abb	Analog input pad
phsosc26_shmitt	Oscillator cell with enable and feedback resistor
phbsu100ct8sm	Bi-directional pad, LVCMOS schmitt-trigger, 100Kohm pull-up resistor with control, tri-state, lo=8mA
phbsu100ct12sm	Bi-directional pad, LVCMOS schmitt-trigger, 100Kohm pull-up resistor with control, tri-state, lo=12mA
phbsud8sm	Bi-directional pad, schmitt-trigger, pull-up resistor with, open-drain control, lo=8mA

**NOTE:** phbsu100ct8sm means a bi-directional pad, but this means input pad so long as phbsu100ct8sm is used for XciCDATA[7:0]

## PIN DESCRIPTIONS

### I/O SIGNAL DESCRIPTIONS

#### External Memory Interface

- Shared Memory Bus (ROM/SRAM/NOR Flash/NAND Flash/External Bus)

Signal	I/O	Description
XrADDR[25:0]	O	XrADDR[25:0] (Address Bus for shared memory) outputs the memory address of the corresponding bank .
XrDATA[15:0]	IO	XrDATA[15:0] (Data Bus) inputs data during memory read and outputs data during memory write. The bus width is programmable among 8/16-bit.
XrCSn[2:0]	O	XrCSn[2:0] (Chip Select) are activated when the address of a memory is within the address region of each bank. The number of access cycles and the bank size can be programmed.
XrWEn	O	XrWEn (Write Enable) indicates that the current bus cycle is a write cycle.
XrOEn	O	XrOEn (Output Enable) indicates that the current bus cycle is a read cycle.
XrWAITn	I	XrWAITn requests to prolong a current bus cycle. As long as XrWAITn n is L, the current bus cycle cannot be completed.
XrnWBE[1:0]	O	Write Byte Enable
XfCLE	O	Nand Flash Command Latch Enable
XfALE	O	Nand Flash Address Latch Enable
XfNFPS	I	Nand Flash Page Size (0:256HWord, 1:512Byte) or Advanced Page size(0:1K Hword , 1:2K Byte)
XfNFBW	I	Nand Flash Bus Width (0:8-bit, 1:16-bit)
XfNFACYC	I	Nand Flash Address Step (0:3-step, 1:4-step) or Advanced Address step(0:4-step, 1:5-step)
XfNFADV	I	To Support advanced 2G Nand Flash
XfRnB[1:0]	I	Nand Flash Ready and Busy

- SDRAM BUS

Signal	I/O	Description
XpCSN[1:0]	O	SDRAM Chip Select
XpCASn	O	SDRAM Column Address Strobe
XpRASn	O	SDRAM Row Address Strobe
XpWEn	O	SDRAM Write Enable
XpCKE	O	SDRAM Clock Enable
XpDQM[3:0]	O	SDRAM Data Mask
XpSCLK	IO	SDRAM Clock
XpADDR[14:0]	O	SDRAM Address bus
XpDATA[31:0]	O	SDRAM Data bus

**Serial Communication**

## • UART

Signal	I/O	Description
XuCLK	I	UART 0 clock signal
XuRXD0	I	UART 0 receives data input
XuCTSn0	I	UART 0 clear to send input signal
XuTXD0	O	UART 0 transmits data output
XuRTSn0	O	UART 0 request to send output signal

## • IIC Bus

Signal	I/O	Description
X2cSDA	IO	IIC-bus data
X2cSCL	IO	IIC-bus clock

## • IIS Bus

Signal	I/O	Description
X2sLRCK	IO	IIS-bus channel select clock
X2sDO	O	IIS-bus serial data output
X2sDI	I	IIS-bus serial data input
X2sCLK	IO	IIS-bus serial clock
X2sCDCLK	O	CODEC system clock

## • SPI Bus

Signal	I/O	Description
XspiSSIn[1:0]	I	SPI chip select(only for slave mode)
XspiCLK	IO	SPI clock for channel 0
XspiMISO	IO	XspiMISO is the master data input line, when SPI is configured as a master. When SPI is configured as a slave, these pins reverse its role. For channel 0
XspiMOSI	IO	XspiMOSI is the master data output line, when SPI is configured as a master. When SPI is configured as a slave, these pins reverse its role. For channel 0

- AC97

Signal	I/O	Description
X97BITCLK	I	AC-Link bit clock(12.288MHz) from AC97 Codec
X97SDI	I	AC-link Serial Data input from AC97 Codec
X97RESETn	O	AC-link Reset to Codec
X97SYNC	O	AC-link Frame Synchronization (Sampling Frequency 48kHz) from AC97 Controller
X97SDO	O	AC-link Serial Data output to AC97 Codec

- USB Host

Signal	I/O	Description
XusDN[1:0]	IO	DATA(-) from USB host
XusDP[1:0]	IO	DATA(+) from USB host

- USB Device

Signal	I/O	Description
XudDN	IO	DATA(-) for USB peripheral device
XudDP	IO	DATA(+) for USB peripheral device

**Parallel Communication**

- GPIO

Signal	I/O	Description
XgpIO[31:0]	IO	General input/output ports

- Modem Interface (8-bit Parallel)

Signal	I/O	Description
XmiCSn	I	Chip select, driven by the Modem chip
XmiWEn	I	Write enable, driven by the Modem chip
XmiOEn	I	Read enable, driven by the Modem chip
XmiADR[10:0]	I	Address bus, driven by the Modem chip
XmiDATA[7:0]	IO	Data bus, driven by the Modem chip
XmiIRQn	O	Interrupt request to the Modem chip

**Image/Video Processing**

- Camera Interface

Signal	I/O	Description
XciPCLK	I	Pixel Clock, driven by the Camera processor
XciVSYNC	I	Vertical Sync, driven by the Camera processor
XciHREF	I	Horizontal Sync, driven by the Camera processor
XciCDATA[7:0]	I	Pixel Data for CbCr in 16-bit mode, driven by the Camera processor
XciYDATA[7:0]	I	Pixel Data for YCbCr in 8-bit mode or for Y in 16-bit mode, driven by the Camera processor
XciCLK	O	Master Clock to the Camera processor
XciRSTn	O	Software Reset to the Camera processor

**Display Control**

- TFT LCD Display Interface

Signal	I/O	Description
XvVD[17:0]	O	LCD pixel data output ports
XvVCLK	O	Pixel clock signal
XvVSYNC	O	Vertical synchronous signal
XvHSYNC	O	Horizontal synchronous signal
XvDEN	O	Data enable signal

**Input Devices**

- Analog-to-Digital Converter and Touch Screen Interface

Signal	I/O	Description
XadcAVREF	AI	ADC reference top
XadcAIN[7:0]	AI	ADC analog input

**Storage Devices**

- Secure Digital (SD) and Memory Stick Interface

Signal	I/O	Description
XsdDAT[3:0]	IO	SD/MMC card receive/transmit Data
XmsPI	I	Input port used for insertion/extraction detect of Memory stick
XmsSDIO	IO	SD/MMC card command signal port (default). If MemoryStick card enable, Memory stick Serial data in/out port
XmsSCLKO	O	SD/MMC card Clock (default). If MemoryStick card enable, MemoryStick Clock
XmsBS	O	MemoryStick Serial bus control signal

**System Management**

- Reset

Signal	I/O	Description
XsRESETn	I	XsRESETn suspends any operation in progress and places S3C24A0A into a known reset state. For a reset, XsRESETn must be held to L level for at least 4 External clock after the processor power has been stabilized.
XsWRESETn	I	System Warm Reset. Reset the whole system while preserves the SDRAM contents
XsRSTOUTn	O	For external device reset control (XsRSTOUTn = XsRESETn & nWDTRST & SW_RESET & XsWRESETn)

- Clock

Signal	I/O	Description
XsMPLLCAP	AO	Loop filter capacitor for main clock.
XsUPLLCAP	AO	Loop filter capacitor for USB clock.
XrtcXTI	AI	32.768KHz crystal input for RTC.
XrtcXTO	AO	32.768KHz crystal output for RTC.
XsXTIN	I	Crystal Input for internal osc circuit.
XsXTOUT	O	Crystal Input for internal osc circuit.
XsEXTCLK	I	External clock source.





**Power -Supply Groups**

- VDD

Signal	I/O	Description
XxVDDlogic	P	Core logic VDD (1.2V) for internal logic
XxVDDalive	P	S3C24A0A reset block and port status register VDD (1.2V). It should be always supplied whether in normal mode or in Stop and Sleep mode.
XxVDDarm	P	Core logic VDD (1.2V) for CPU
XxVDDMpll	P	S3C24A0A MPLL analog and digital VDD (1.2 V).
XxVDDUpll	P	S3C24A0A UPLL analog and digital VDD (1.2V)
XxVDDpadIO	P	S3C24A0A I/O port VDD (3.3V)
XxVDDpadSDRAM	P	S3C24A0A SDRAM memory IO VDD (3.3V)
XxVDDpadFlash	P	S3C24A0A NFLASH memory IO VDD (3.3V)
XxVDDpadUSB	P	S3C24A0A USB IO VDD (3.3V)
XrtcVDD	P	RTC VDD (3.3V) (Although RTC function is not used, this pin should be connected to power)
XadcVDD	P	S3C24A0A ADC VDD(3.3V)
XxVDDpadModem	P	S3C24A0A MODEM IO VDD (3.3V)

- VSS

Signal	I/O	Description
VSS	P	Core logic VSS for internal logic
		VSS for S3C24A0A reset block and port status register
		Core logic VSS for CPU
		S3C24A0A I/O port VSS
XxVSSpadSDRAM	P	S3C24A0A SDRAM memory IO VSS
XxVSSpadFlash	P	S3C24A0A Flash memory IO VSS
XxVSSpadUSB	P	S3C24A0A USB IO VSS
XxVSSMpll	P	S3C24A0A MPLL analog and digital VSS.
XxVSSUpll	P	S3C24A0A UPLL analog and digital VSS
XrtcVSS	P	RTC VSS
XadcVSS	P	S3C24A0A ADC VSS

**NOTES:**

- I/O means input/output.
- AI/AO means analog input/output.
- P means power.

ADDRESS MAP

ADDRESS SPACE ASSIGNMENT OVERVIEW

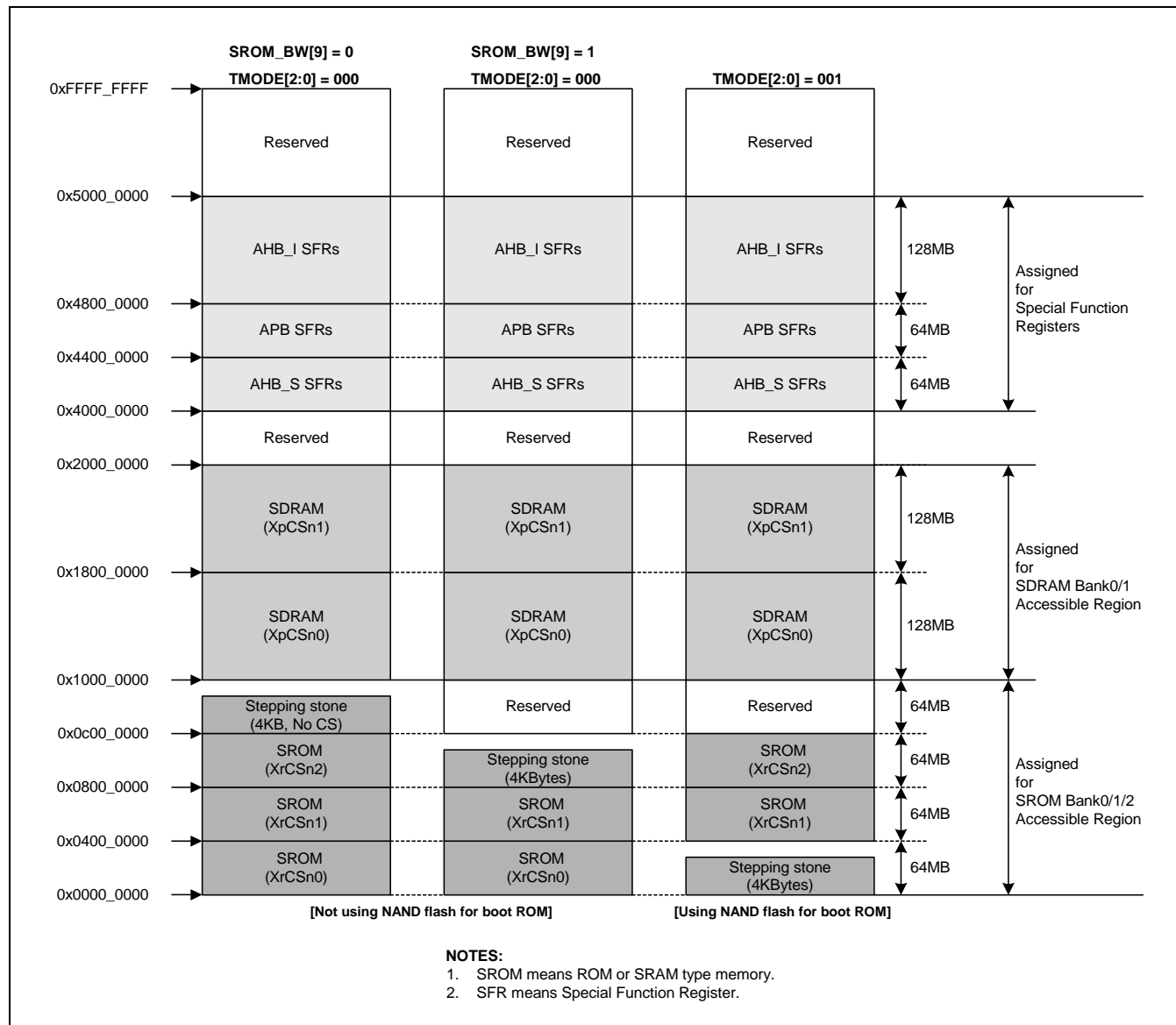

Figure 1-3. Address Map

**DEVICE SPECIFIC ADDRESS SPACE**

- AHB\_S (System-side AHB Bus) Devices: Base = 0x4000\_0000 (just above 1GB), Size = 64MB
  - Physical Address = Base Address + Device Offset + Register Offset

Device Offset	Size (MB)	Group	Device	Note
0x00_0_0000	1	AHB_S	SystemCtrl	
0x01_0_0000	1	AHB_S	Reserved	
0x02_0_0000	1	AHB_S	INTC	
0x03_0_0000	1	AHB_S	Reserved	
0x04_0_0000	1	AHB_S	DMA 0	
0x05_0_0000	1	AHB_S	DMA 1	
0x06_0_0000	1	AHB_S	DMA 2	
0x07_0_0000	1	AHB_S	DMA 3	
0x08_0_0000	4	AHB_S	Reserved	
0x0C_0_0000	1	AHB_S	MemCtrl	
0x0D_0_0000	3	AHB_S	Reserved	
0x10_0_0000	1	AHB_S	USB Host	
0x11_0_0000	1	AHB_S	Modem IF0	
0x12_0_0000	6	AHB_S	Reserved	
0x18_0_0000	1	AHB_S	IrDA	
0x19_0_0000	7	AHB_S	Reserved	
0x20_0_0000	16	AHB_S	EXT AHB	
0x30_0_0000	16	AHB_S	Reserved	
0x40_0_0000	64	AHB_S	APB devices	Through AHB to APB Bridge
0x80_0_0000	128	AHB_S	AHB_I devices	Through AHB to AHB Bridge

- APB Devices: Base = 0x4000\_0000

Device Offset	Size (MB)	Group	Device	Note
0x40_0_0000	1	APB	PWM Timer	
0x41_0_0000	1	APB	Watch Dog Timer	
0x42_0_0000	1	APB	RTC	
0x43_0_0000	1	APB	Reserved	
0x44_0_0000	1	APB	UART	
0x45_0_0000	1	APB	SPI	
0x46_0_0000	1	APB	I2C	
0x47_0_0000	1	APB	I2S	
0x48_0_0000	1	APB	GPIO	
0x49_0_0000	1	APB	KEYPAD Interface	
0x4A_0_0000	1	APB	USB Device	
0x4B_0_0000	5	APB	Reserved	
0x50_0_0000	1	APB	AC97	
0x51_0_0000	7	APB	Reserved	
0x58_0_0000	1	APB	ADC/Touch Screen	
0x59_0_0000	7	APB	Reserved	
0x60_0_0000	1	APB	SD/MMC	
0x61_0_0000	1	APB	Memory Stick	
0x62_0_0000	14	APB	Reserved	
0x70_0_0000	16	APB	Reserved	

- AHB\_I (the AHB Bus for the Image Subsystem) Devices: Base = 0x4000\_0000

Offset (Hex)	Size (MB)	Group	Device	Note
0x80_0_0000	4	AHB_I	Camera Inteface	
0x84_0_0000	4	AHB_I	Reserved	
0x88_0_0000	4	AHB_I	ME	
0x8C_0_0000	4	AHB_I	MC	
0x90_0_0000	4	AHB_I	DCT/Q	
0x94_0_0000	12	AHB_I	Reserved	
0xA0_0_0000	1	AHB_I	Display Controller	
0xA1_0_0000	1	AHB_I	Video POST Processor	
0xA2_0_0000	4	AHB_I	Reserved	
0xA4_0_0000	10	AHB_I	VLX	
0xB0_0_0000	16	AHB_I	Reserved	
0xC0_0_0000	16	AHB_I	Reserved	
0xD0_0_0000	16	AHB_I	Reserved	
0xE0_0_0000	16	AHB_I	Reserved	
0xF0_0_0000	16	AHB_I	Reserved	

**INTERNAL REGISTERS**

The base of all devices internal registers = 0x4000\_0000

**External Memory Interface**

- NAND Flash Controller

Register Name	Offset	Acc. Unit	Read/Write	Function
NFCONF	0x0C0_0000	W	R/W	NAND flash configuration
NFCONT	0x0C0_0004			NAND flash control
NFCMMD	0x0C0_0008			NAND flash command
NFADDR	0x0C0_000C			NAND flash address
NFDATA	0x0C0_0010			NAND flash data
NFMECCDATA0	0x0C0_0014			NAND flash main area ECC data reg.0
NFMECCDATA1	0x0C0_0018			NAND flash main area ECC data reg.1
NFMECCDATA2	0x0C0_001C			NAND flash main area ECC data reg.2
NFMECCDATA3	0x0C0_0020			NAND flash main area ECC data reg.3
NFSECCDATA0	0x0C0_0024			NAND flash spare area ECC data reg.1
NFSECCDATA1	0x0C0_0028			NAND flash spare area ECC data reg.2
NFSTAT	0x0C0_002C		R	NAND flash status
NFESTAT0	0x0C0_0030			NAND flash ECC status 0 for I/O[7:0]
NFESTAT1	0x0C0_0034			NAND flash ECC status 1 for I/O[15:8]
NFMECC0	0x0C0_0038			NAND flash main area ECC reg.0
NFMECC1	0x0C0_003C			NAND flash main area ECC reg.1
NFSECC	0x0C0_0040			NAND flash spare area ECC reg.
NFSBLK	0x0C0_0044			R/W
NFEBLK	0x0C0_0048		NAND flash end block address	



- SROM Controller

Register Name	Offset	Acc. Unit	Read/Write	Function
SROM_BW	0x0C2_0000	W	R/W	SROM bus width & wait control
SROM_BC0	0x0C2_0004			SROM bank0 Control register
SROM_BC1	0x0C2_0008			SROM bank1 Control register
SROM_BC2	0x0C2_000C			SROM bank2 Control register

- SDRAM Controller

Register Name	Offset	Acc. Unit	Read/Write	Function
SDRAM_BANKCFG	0x0C4_0000	W	R/W	SDRAM configuration
SDRAM_BANKCON	0x0C4_0004			SDRAM control
SDRAM_REFRESH	0x0C4_0008			SDRAM refresh control

- BUS Matrix

Register Name	Offset	Acc. Unit	Read/Write	Function
PRIORITY0	0x0CE_0000	W	R/W	Priority control for SROMC/NFLASHC
PRIORITY1	0x0CE_0004			Priority control for SDRAMC

### General Peripherals

- Interrupt Controller

Register Name	Offset	Acc. Unit	Read/Write	Function		
SRCPND	0x020_0000	W	R/W	Interrupt request status		
INTMOD	0x020_0004			Interrupt mode control		
INTMSK	0x020_0008			Interrupt mask control		
PRIORITY	0x020_000C			IRQ priority control		
INTPND	0x020_0010		R	R	Interrupt request status	
INTOFFSET	0x020_0014				Interrupt request source offset	
SUBSRCPND	0x020_0018			R/W	R	Sub source pending
INTSUBMSK	0x020_001C					Interrupt sub mask
VECINTMOD	0x020_0020					Vectored interrupt mode
VECADDR	0x020_0024			R/W	R	Vectored mode address
NVECADDR	0x020_0028				Non-vectored mode address	
VAR	0x020_002C				R	Vector address register

- Timer with PWM (Pulse Width Modulation)

Register Name	Offset	Acc. Unit	Read/Write	Function
TCFG0	0x400_0000	W	R/W	Timer configuration
TCFG1	0x400_0004			Timer configuration
TCON	0x400_0008			Timer control
TCNTB0	0x400_000C			Timer count buffer 0
TCMPB0	0x400_0010			Timer compare buffer 0
TCNTO0	0x400_0014			R
TCNTB1	0x400_0018		R/W	Timer count buffer 1
TCMPB1	0x400_001C			Timer compare buffer 1
TCNTO1	0x400_0020		R	Timer count observation 1
TCNTB2	0x400_0024		R/W	Timer count buffer 2
TCMPB2	0x400_0028			Timer compare buffer 2
TCNTO2	0x400_002C		R	Timer count observation 2
TCNTB3	0x400_0030		R/W	Timer count buffer 3
TCMPB3	0x400_0034			Timer compare buffer 3
TCNTO3	0x400_0038		R	Timer count observation 3
TCNTB4	0x400_003C		R/W	Timer count buffer 4
TCNTO4	0x400_0040	R	Timer count observation 4	

- 16-bit Watchdog Timer.

Register Name	Offset	Acc. Unit	Read/Write	Function
WTCON	0x410_0000	W	R/W	Watch-dog timer mode
WTDAT	0x410_0004			Watch-dog timer data
WTCNT	0x410_0008			Watch-dog timer count

- 4-ch DMA controller.

Register Name	Offset	Acc. Unit	Read/Write	Function
DISRC0	0x040_0000	W	R/W	DMA 0 initial source
DISRCC0	0x040_0004			DMA 0 initial source control
DIDST0	0x040_0008			DMA 0 initial destination
DIDSTC0	0x040_000C			DMA 0 initial destination control
DCON0	0x040_0010			DMA 0 control
DSTAT0	0x040_0014			R
DCSRC0	0x040_0018	DMA 0 current source		
DCDST0	0x040_001C	DMA 0 current destination		
DMASKTRIG0	0x040_0020	W	R/W	DMA 0 mask trigger
DISRC1	0x050_0000			DMA 1 initial source
DISRCC1	0x050_0004			DMA 1 initial source control
DIDST1	0x050_0008			DMA 1 initial destination
DIDSTC1	0x050_000C			DMA 1 initial destination control
DCON1	0x050_0010			DMA 1 control
DSTAT1	0x050_0014	R	DMA 1 count	
DCSRC1	0x050_0018		DMA 1 current source	
DCDST1	0x050_001C		DMA 1 current destination	
DMASKTRIG1	0x050_0020	W	R/W	DMA 1 mask trigger
DISRC2	0x060_0000			DMA 2 initial source
DISRCC2	0x060_0004			DMA 2 initial source control
DIDST2	0x060_0008			DMA 2 initial destination
DIDSTC2	0x060_000C			DMA 2 initial destination control
DCON2	0x060_0010			DMA 2 control
DSTAT2	0x060_0014	R	DMA 2 count	
DCSRC2	0x060_0018		DMA 2 current source	
DCDST2	0x060_001C		DMA 2 current destination	
DMASKTRIG2	0x060_0020	W	R/W	DMA 2 mask trigger
DISRC3	0x070_0000			DMA 3 initial source
DISRCC3	0x070_0004			DMA 3 initial source control
DIDST3	0x070_0008			DMA 3 initial destination
DIDSTC3	0x070_000C			DMA 3 initial destination control
DCON3	0x070_0010			DMA 3 control
DSTAT3	0x070_0014	R	DMA 3 count	
DCSRC3	0x070_0018		DMA 3 current source	
DCDST3	0x070_001C		DMA 3 current destination	
DMASKTRIG3	0x070_0020	W	R/W	DMA 3 mask trigger

- RTC (Real Time Clock)

Register Name	Offset	Acc. Unit	Read/Write	Function
RTCCON	0x420_0040	B	R/W	RTC control
TICINT	0x420_0044			Tick time count
RTCALM	0x420_0050			RTC alarm control
ALMSEC	0x420_0054			Alarm second
ALMMIN	0x420_0058			Alarm minute
ALMHOUR	0x420_005C			Alarm hour
ALMDATE	0x420_0060			Alarm day
ALMMON	0x420_0064			Alarm month
ALMYEAR	0x420_0068			Alarm year
RTCRST	0x420_006C			RTC round reset
BCDSEC	0x420_0070			BCD second
BCDMIN	0x420_0074			BCD minute
BCDHOUR	0x420_0078			BCD hour
BCDDATE	0x420_007C			BCD day
BCDDAY	0x420_0080			BCD date
BCDMON	0x420_0084			BCD month
BCDYEAR	0x420_0088	BCD year		

**Serial Communication**

## • UART

Register Name	Offset	Acc. Unit	Read/Write	Function
ULCON0	0x440_0000	W	R/W	UART 0 line control
UCON0	0x440_0004			UART 0 control
UFCON0	0x440_0008			UART 0 FIFO control
UMCON0	0x440_000C			UART 0 modem control
UTRSTAT0	0x440_0010		R	UART 0 Tx/Rx status
UERSTAT0	0x440_0014			UART 0 Rx error status
UFSTAT0	0x440_0018			UART 0 FIFO status
UMSTAT0	0x440_001C			UART 0 modem status
UTXH0	0x440_0020	B	W	UART 0 transmission hold
URXH0	0x440_0024		R	UART 0 receive buffer
UBRDIV0	0x440_0028	W	R/W	UART 0 baud rate divisor
ULCON1	0x440_4000	W	R/W	UART 1 line control
UCON1	0x440_4004			UART 1 control
UFCON1	0x440_4008			UART 1 FIFO control
UMCON1	0x440_400C			UART 1 modem control
UTRSTAT1	0x440_4010		R	UART 1 Tx/Rx status
UERSTAT1	0x440_4014			UART 1 Rx error status
UFSTAT1	0x440_4018			UART 1 FIFO status
UMSTAT1	0x440_401C			UART 1 modem status
UTXH1	0x440_4020	B	W	UART 1 transmission hold
URXH1	0x440_4024		R	UART 1 receive buffer
UBRDIV1	0x440_4028	W	R/W	UART 1 baud rate divisor

• IIC-Bus Interface

Register Name	Offset	Acc. Unit	Read/Write	Function
IICCON	0x460_0000	W	R/W	IIC control
IICSTAT	0x460_0004			IIC status
IICADD	0x460_0008			IIC address
IICDS	0x460_000C			IIC data shift
IICSDADLY	0x460_0010	1-bit		SDA output delay

• IIS-Bus Interface

Register Name	Offset	Acc. Unit	Read/Write	Function
IISCON	0x470_0000	W	R/W	IIS control
IISMOD	0x470_0004	W		IIS mode
IISPSR	0x470_0008	W		IIS prescaler
IISFCON	0x470_000C	W		IIS FIFO control
IISFIFO	0x470_0010	HW		IIS FIFO entry

• SPI Interface

Register Name	Offset	Acc. Unit	Read/Write	Function
SPCON0	0x450_0000	W	R/W	SPI channel 0 control
SPSTA0	0x450_0004		R	SPI channel 0 status
SPPIN0	0x450_0008		R/W	SPI channel 0 pin control
SPPRE0	0x450_000C			SPI channel 0 baud rate prescaler
SPTDAT0	0x450_0010			SPI channel 0 Tx data
SPRDAT0	0x450_0014		R	SPI channel 0 Rx data
SPCON1	0x450_0020		R/W	SPI channel 1 control
SPSTA1	0x450_0024		R	SPI channel 1 status
SPPIN1	0x450_0028		R/W	SPI channel 1 pin control
SPPRE1	0x450_002C			SPI channel 1 baud rate prescaler
SPTDAT1	0x450_0030			SPI channel 1 Tx data
SPRDAT1	0x450_0034		R	SPI channel 1 Rx data

- AC97 Audio-CODEC Interface

Register Name	Offset	Acc. Unit	Read/ Write	Function
AC_GLBCTRL	0x500_0000	W	R/W	AC97 global control
AC_GLBSTAT	0x500_0004		R	AC97 global status
AC_CODEEC_CMD	0x500_0008		R/W	AC97 codec command
AC_CODEEC_STAT	0x500_000C		R	AC97 codec status
AC_PCM_ADDR	0x500_0010		R	AC97 PCM out/in channel FIFO address
AC_MICADDR	0x500_0014		R	AC97 MIC in channel FIFO address
AC_PCMDATA	0x500_0018		R/W	AC97 PCM out/in channel FIFO data
AC_MICDATA	0x500_001C		R/W	AC97 MIC in channel FIFO data

- USB Host

Register Name	Offset	Acc. Unit	Read/ Write	Function
HcRevision	0x100_0000	W		Control and status group
HcControl	0x100_0004			
HcCommonStatus	0x100_0008			
HcInterruptStatus	0x100_000C			
HcInterruptEnable	0x100_0010			
HcInterruptDisable	0x100_0014			
HcHCCA	0x100_0018			Memory pointer group
HcPeriodCurrentED	0x100_001C			
HcControlHeadED	0x100_0020			
HcControlCurrentED	0x100_0024			
HcBulkHeadED	0x100_0028			
HcBulkCurrentED	0x100_002C			
HcDoneHead	0x100_0030			Frame counter group
HcRmInterval	0x100_0034			
HcFmRemaining	0x100_0038			
HcFmNumber	0x100_003C			
HcPeriodicStart	0x100_0040			
HcLSThreshold	0x100_0044			
HcRhDescriptorA	0x100_0048	Root HUB group		
HcRhDescriptorB	0x100_004C			
HcRhStatus	0x100_0050			
HcRhPortStatus1	0x100_0054			
HcRhPortStatus2	0x100_0058			

• USB Device

Register Name	Offset	Acc. Unit	Read/Write	Function
FUNC_ADDR_REG	0x4A0_0140	B	R/W	Function address
PWR_REG	0x4A0_0144			Power management
EP_INT_REG	0x4A0_0148			EP interrupt pending and clear
USB_INT_REG	0x4A0_0158			USB interrupt pending and clear
EP_INT_EN_REG	0x4A0_015C			Interrupt enable
USB_INT_EN_REG	0x4A0_016C			Interrupt enable
FRAME_NUM1_REG	0x4A0_0170		R	Frame number lower byte
INDEX_REG	0x4A0_0178		R/W	Register index
EP0_CSR	0x4A0_0184			Endpoint 0 status
IN_CSR1_REG	0x4A0_0184			In endpoint control status
IN_CSR2_REG	0x4A0_0188			In endpoint control status
MAXP_REG	0x4A0_0180			Endpoint max packet
OUT_CSR1_REG	0x4A0_0190			Out endpoint control status
OUT_CSR2_REG	0x4A0_0194			Out endpoint control status
OUT_FIFO_CNT1_REG	0x4A0_0198			R
OUT_FIFO_CNT2_REG	0x4A0_019C		Endpoint out write count	
EP0_FIFO	0x4A0_01C0	R/W	Endpoint 0 FIFO	
EP1_FIFO	0x4A0_01C4		Endpoint 1 FIFO	
EP2_FIFO	0x4A0_01C8		Endpoint 2 FIFO	
EP3_FIFO	0x4A0_01CC		Endpoint 3 FIFO	
EP4_FIFO	0x4A0_01D0		Endpoint 4 FIFO	
EP1_DMA_CON	0x4A0_0200		EP1 DMA interface control	
EP1_DMA_UNIT	0x4A0_0204		EP1 DMA Tx unit counter	
EP1_DMA_FIFO	0x4A0_0208		EP1 DMA Tx FIFO counter	
EP1_DMA_TTC_L	0x4A0_020C		EP1 DMA total Tx counter	
EP1_DMA_TTC_M	0x4A0_0210		EP1 DMA total Tx counter	
EP1_DMA_TTC_H	0x4A0_0214		EP1 DMA total Tx counter	
EP2_DMA_CON	0x4A0_0218		B	R/W
EP2_DMA_UNIT	0x4A0_021C	EP2 DMA Tx Unit counter		
EP2_DMA_FIFO	0x4A0_0220	EP2 DMA Tx FIFO counter		
EP2_DMA_TTC_L	0x4A0_0224	EP2 DMA total Tx counter		
EP2_DMA_TTC_M	0x4A0_0228	EP2 DMA total Tx counter		
EP2_DMA_TTC_H	0x4A0_022C	EP2 DMA total Tx counter		
EP3_DMA_CON	0x4A0_0240	EP3 DMA interface control		



- USB Device (Continued)

Register Name	Offset	Acc. Unit	Read/Write	Function
EP3_DMA_UNIT	0x4A0_0244			EP3 DMA Tx unit counter
EP3_DMA_FIFO	0x4A0_0248			EP3 DMA Tx FIFO counter
EP3_DMA_TTC_L	0x4A0_024C			EP3 DMA total Tx counter
EP3_DMA_TTC_M	0x4A0_0250			EP3 DMA total Tx counter
EP3_DMA_TTC_H	0x4A0_0254			EP3 DMA total Tx counter
EP4_DMA_CON	0x4A0_0258			EP4 DMA interface control
EP4_DMA_UNIT	0x4A0_025C			EP4 DMA Tx Unit counter
EP4_DMA_FIFO	0x4A0_0260			EP4 DMA Tx FIFO counter
EP4_DMA_TTC_L	0x4A0_0264			EP4 DMA total Tx counter
EP4_DMA_TTC_M	0x4A0_0268			EP4 DMA total Tx counter
EP4_DMA_TTC_H	0x4A0_026C			EP4 DMA total Tx counter

• IrDA

Register Name	Offset	Acc. Unit	Read/Write	Function
IrDA_CNT	0x180_0000	W	R/W	IrDA control
IrDA_MDR	0x180_0004			IrDA mode definition
IrDA_CNF	0x180_0008			IrDA interrupt / DMA configuration
IrDA_IER	0x180_000C			IrDA interrupt enable
IrDA_IIR	0x180_0010		R	IrDA interrupt identification
IrDA_LSR	0x180_0014		IrDA line status	
IrDA_FCR	0x180_0018		R/W	IrDA FIFO control
IrDA_PLR	0x180_001C			IrDA preamble length
IrDA_RBR	0x180_0020			IrDA receiver & transmitter buffer
IrDA_TXNO	0x180_0024		R	The total number of data bytes remained in Tx FIFO
IrDA_RXNO	0x180_0028			The total number of data bytes remained in Rx FIFO
IrDA_TXFLL	0x180_002C		R/W	IrDA transmit frame-length register low
IrDA_TXFLH	0x180_0030			IrDA transmit frame-length register high
IrDA_RXFLL	0x180_0034			IrDA receive frame-length register low
IrDA_RXFLH	0x180_0038			IrDA receive frame-length register high

### Parallel Communication

- Modem Interface

Register Name	Offset	Acc. Unit	Read/Write	Function
INT2AP	0x118_0000	W	R/W	Interrupt request to AP register
INT2MDM	0x118_0004			Interrupt request to modem register

- GPIO

Register Name	Offset	Acc. Unit	Read/Write	Function
GPCON_U	0x480_0000	W	R/W	GPIO ports configuration register
GPCON_M	0x480_0004			GPIO ports configuration register
GPCON_L	0x480_0008			GPIO ports configuration register
GPDAT	0x480_000C			GPIO ports data register
GPPU	0x480_0010			GPIO ports pull-up control register
EXTINTC0	0x480_0018			External interrupt control register 0
EXTINTC1	0x480_001C			External interrupt control register 1
EXTINTC2	0x480_0020			External interrupt control register 2
EINTFLT0	0x480_0024			External interrupt filter control register 0
EINTFLT1	0x480_0028			External interrupt filter control register 1
EINTMASK	0x480_0034			External interrupt mask register
EINTPEND	0x480_0038			External interrupt pending register
PERIPU	0x480_0040			Peri. ports pull-up control register
ALIVECON	0x480_0044			Alive control register
GPDAT_SLEEP	0x480_0048			GPIO output data for sleep mode
GPOEN_SLEEP	0x480_004C			GPIO output enable control for sleep mode
GPPU_SLEEP	0x480_0050			GPIO pull-up control register for sleep mode
PERIDAT_SLEEP0	0x480_0054			Peri. ports output data control register 0 for sleep mode
PERIDAT_SLEEP1	0x480_0058			Peri. ports output data control register 1 for sleep mode
PERIOEN_SLEEP0	0x480_005C			Peri. ports output control register 0 for sleep mode
PERIOEN_SLEEP1	0x480_0060			Peri. ports output control register 1 for sleep mode
PERIPU_SLEEP	0x480_0064			Peri. ports pull-up control register for sleep mode
RSTCNT	0x480_0068			Reset count compare register
GPRAM0~15	0x480_0080~0x480_00BC			General purpose RAM array



## Image/Video Processing

- Camera Interface

Register Name	Offset	Acc. Unit	Read/Write	Function	
CISRCFMT	0x800_0000	W	R/W	Input source format	
CIWDOFST	0x800_0004			Window offset register	
CIGCTRL	0x800_0008			Global control register	
CICOYSA1	0x800_0018			Y 1 <sup>st</sup> frame start address for codec DMA	
CICOYSA2	0x800_001C			Y 2 <sup>nd</sup> frame start address for codec DMA	
CICOYSA3	0x800_0020			Y 3 <sup>rd</sup> frame start address for codec DMA	
CICOYSA4	0x800_0024			Y 4 <sup>th</sup> frame start address for codec DMA	
CICOCBSA1	0x800_0028			Cb 1 <sup>st</sup> frame start address for codec DMA	
CICOCBSA2	0x800_002C			Cb 2 <sup>nd</sup> frame start address for codec DMA	
CICOCBSA3	0x800_0030			Cb 3 <sup>rd</sup> frame start address for codec DMA	
CICOCBSA4	0x800_0034			Cb 4 <sup>th</sup> frame start address for codec DMA	
CICOCRSA1	0x800_0038			Cr 1 <sup>st</sup> frame start address for codec DMA	
CICOCRSA2	0x800_003C			Cr 2 <sup>nd</sup> frame start address for codec DMA	
CICOCRSA3	0x800_0040			Cr 3 <sup>rd</sup> frame start address for codec DMA	
CICOCRSA4	0x800_0044			Cr 4 <sup>th</sup> frame start address for codec DMA	
CICOTRGFMT	0x800_0048			Target image format of codec DMA	
CICOCTRL	0x800_004C			Codec DMA control related	
CICOSCPRERATIO	0x800_0050			Codec pre-scaler ratio control	
CICOSCPREDST	0x800_0054			Codec pre-scaler destination format	
CICOSCCTRL	0x800_0058			Codec main-scaler control	
CICOTAREA	0x800_005C			Codec pre-scaler destination format	
CICOSTATUS	0x800_0064			R	Codec path status
CIPRCLRSA1	0x800_006C			R/W	RGB 1 <sup>st</sup> frame start address for preview DMA
CIPRCLRSA2	0x800_0070				RGB 2 <sup>nd</sup> frame start address for preview DMA
CIPRCLRSA3	0x800_0074				RGB 3 <sup>rd</sup> frame start address for preview DMA
CIPRCLRSA4	0x800_0078				RGB 4 <sup>th</sup> frame start address for preview DMA
CIPRTRGFMT	0x800_007C				Target image format of preview DMA
CIPRCTRL	0x800_0080				Preview DMA control related
CIPRSCPRERATIO	0x800_0084				Preview pre-scaler ratio control
CIPRSCPREDST	0x800_0088	Preview pre-scaler destination format			
CIPRSCCTRL	0x800_008C	Preview main-scaler control			
CIPRTAREA	0x800_0090	Preview pre-scaler destination format			
CIPRSTATUS	0x800_0098	R	Preview path status		
CIIMGCPPT	0x800_00A0	R/W	Image capture enable command		

- Video POST

Register Name	Offset	Acc. Unit	Read/Write	Function
MODE	0xA10_0000	W	R/W	Mode Register [9:0]
PreScale_Ratio	0xA10_0004			Pre-Scale ratio for vertical and horizontal.
PreScaleImgSize	0xA10_0008			Pre-Scaled image size
SRCImgSize	0xA10_000C			Source image size
MainScale_H_Ratio	0xA10_0010			Main scale ratio along to horizontal direction
MainScale_V_Ratio	0xA10_0014			Main scale ratio along to vertical direction
DSTImgSize	0xA10_0018			Destination image size
PreScale_SHFactor	0xA10_001C			Pre-scale shift factor
ADDRStart_Y	0xA10_0020			DMA Start address for Y or RGB component
ADDRStart_Cb	0xA10_0024			DMA Start address for Cb component
ADDRStart_Cr	0xA10_0028			DMA Start address for Cr component
ADDRStart_RGB	0xA10_002C			DMA Start address for RGB component
ADDREnd_Y	0xA10_0030			DMA End address for Y or RGB component
ADDREnd_Cb	0xA10_0034			DMA End address for Cb component
ADDREnd_Cr	0xA10_0038			DMA End address for Cr component
ADDREnd_RGB	0xA10_003C			DMA End address for RGB component
Offset_Y	0xA10_0040			Offset of Y component for fetching source image
Offset_Cb	0xA10_0044			Offset of Cb component for fetching source image
Offset_Cr	0xA10_0048			Offset of Cr component for fetching source image
Offset_RGB	0xA10_004C	Offset of RGB component for restoring destination image		

- ME

Register Name	Offset	Acc. Unit	Read/Write	Function
ME_CFSA	0x880_0000	W	R/W	Current Frame Start Address Register
ME_PFSA	0x880_0004			Previous Frame Start Address Register
ME_MVSA	0x880_0008			Motion Vector Start Address Register
ME_CMND	0x880_000C			Command Register
ME_STAT_SWR	0x880_0010			Status & S/W Reset Register
ME_CNFG	0x880_0014			Configuration Register
ME_IMGfmt	0x880_0018			Image Format Register

• MC

Register Name	Offset	Acc. Unit	Read/Write	Function
MC_PFYSA_ENC	0x8C0_0000	W	R/W	Previous frame Y start address register for the encoder
MC_CFYSA_ENC	0x8C0_0004			MCed frame Y start address register for the encoder
MC_PFYSA_DEC	0x8C0_0008			Previous frame Y start address register for the decoder
MC_CFYSA_DEC	0x8C0_000C			MCed frame Y start address register for the decoder
MC_PFCbSA_ENC	0x8C0_0010			Previous frame Cb start address register for the encoder
MC_PFCrSA_ENC	0x8C0_0014			Previous frame Cr start address register for the encoder
MC_CFCbSA_ENC	0x8C0_0018			MCed frame Cb start address register for the encoder
MC_CFCrSA_ENC	0x8C0_001C			MCed frame Cr start address register for the encoder
MC_PFCbSA_DEC	0x8C0_0020			Previous frame Cb start address register for the decoder
MC_PFCrSA_DEC	0x8C0_0024			Previous frame Cr start address register for the decoder
MC_CFCbSA_DEC	0x8C0_0028			MCed frame Cb start address register for the decoder
MC_CFCrSA_DEC	0x8C0_002C			MCed frame Cr start address register for the decoder
MC_MVSA_ENC	0x8C0_0030			Motion vector start address register for the encoder
MC_MVSA_DEC	0x8C0_0034			Motion vector start address register for the decoder
MC_CMND	0x8C0_0038			Command register
MC_STAT_SWR	0x8C0_003C			Status & S/W reset register
MC_CNFG	0x8C0_0040			Configuration register
MC_IMGfmt	0x8C0_0044			Image format register



- DCTQ

Register Name	Offset	Acc. Unit	Read/Write	Function
SAYCF	0x900_0000	W	R/W	Current frame luminance start address
SACBCF	0x900_0004			Current frame Cb start address
SACRCF	0x900_0008			Current frame Cr start address
SAYRF	0x900_000C			Reconstruction frame luminance start address
SACBRF	0x900_0010			Reconstruction frame Cb start address
SACRRF	0x900_0014			Reconstruction frame Cr start address
SAYDQF	0x900_0018			DCTQed frame luminance start address
SACBDQF	0x900_001C			DCTQed frame Cb start address
SACRDQF	0x900_0020			DCTQed frame Cr start address
SAQP	0x900_0024			Qp start address
IMGSIZE	0x900_0028			Image horizontal and vertical pixel number
SHQ	0x900_002C			Short header quantization mode
DCTQCTRL	0x900_0034			Control register

- VLX

Register Name	Offset	Acc. Unit	Read/Write	Function	
VLX_COMMON1	0x940_0000	W	R/W	VLX common control register1	
VLX_FRAMESTARTY	0x940_0004			Y coeff. start address	
VLX_FRAMESTARTCB	0x940_0008			Cb coeff. frame start address	
VLX_FRAMESTARTCR	0x940_000C			Cr coeff. frame start address	
VLC_CON1	0x940_0010			Control register in VLC mode	
VLC_CON2	0x940_0014			Reserved	
VLC_CON3	0x940_0018			VLC result external address	
VLC_CON4	0x940_001C			Reserved	
VLD_CON1	0x940_0020			Control register in VLD mode	
VLD_CON2	0x940_0024			VLCed bit stream start address	
VLD_CON3	0x940_0028			Reserved	
VLX_OUT1	0x940_002C			R	VLX output information register 1
VLX_OUT2	0x940_0030				VLX output information register 2

**Display Control**

- TFT LCD Controller

Register	Offset	Acc. Unit	R/W	Function
LCDCON1	0xA00_0000	W	R/W	LCD control 1
LCDCON2	0xA00_0004		R/W	LCD control 2
LCDTCON1	0xA00_0008		R/W	LCD time control 1
LCDTCON2	0xA00_000C		R/W	LCD time control 2
LCDTCON3	0xA00_0010		R/W	LCD time control 3
LCDOSD1	0xA00_0014		R/W	LCD OSD control register
LCDOSD2	0xA00_0018		R/W	Foreground image(OSD Image) left top position set
LCDOSD3	0xA00_001C		R/W	Foreground image(OSD Image) right bottom position set
LCDSADDRB1	0xA00_0020		R/W	frame buffer start address 1 (background buffer 1)
LCDSADDRB2	0xA00_0024		R/W	Frame buffer start address 2 (background buffer 2)
LCDSADDRF1	0xA00_0028		R/W	Frame buffer start address 1 (foreground buffer 1)
LCDSADDRF2	0xA00_002C		R/W	Frame buffer start address 2 (foreground buffer 2)
LCDEADDRB1	0xA00_0030		R/W	Frame buffer end address 1 (background buffer 1)
LCDEADDRB2	0xA00_0034		R/W	Frame buffer end address 2 (background buffer 2)
LCDEADDRF1	0xA00_0038		R/W	Frame buffer end address 1 (foreground buffer 1)
LCDEADDRF2	0xA00_003C		R/W	Frame buffer end address 2 (foreground buffer 2)
LCDVSCRB1	0xA00_0040		R/W	Virtual screen offsize and pagewidth (Background buffer 1)
LCDVSCRB2	0xA00_0044		R/W	Virtual screen offsize and pagewidth (Background buffer 2)
LCDVSCRF1	0xA00_0048		R/W	Virtual screen offsize and pagewidth (Foreground buffer 1)
LCDVSCRF2	0xA00_004C		R/W	Virtual screen offsize and pagewidth (Foreground buffer 2)
LCDINTCON	0xA00_0050		R/W	LCD Interrupt Control
LCDKEYCON	0xA00_0054		R/W	Color key control 1
LCDKEYVAL	0xA00_0058		R/W	Color key control 2
LCDBGCON	0xA00_005C		R/W	Back-ground color Control
LCDFGCON	0xA00_0060		R/W	Fore-ground color Control
LCDDITHCON	0xA00_0064		R/W	LCD dithering control for active matrix

**Input Devices**

- Keypad Interface

Register Name	Offset	Acc. Unit	Read/Write	Function
KEYDAT	0x490_0000	W	R/W	The data register for KEYPAD input
KEYINTC	0x490_0004			KEYPAD input ports interrupt control
KEYFLT0	0x490_0008			KEY PAD input filter control
KEYFLT1	0x490_000C			KEY PAD input filter control
KEYMAN	0x490_0010			KEYPAD manual scan control

- Analog-to-Digital Converter and Touch Screen Interface

Register Name	Offset	Acc. Unit	Read/Write	Function
ADCCON	0x580_0000	W	R/W	ADC control
ADCTSC	0x580_0004			ADC touch screen control
ADCPLY	0x580_0008			ADC start or interval delay
ADCDAV	0x580_000C		R	ADC conversion data register X
ADCDAV	0x580_0010			ADC conversion data register Y

**Storage Devices**

- SD and SDIO / MMC

Register Name	Offset	Acc. Unit	Read/Write	Function
SDICON	0x600_0000	W	R/W	SDI control
SDIPRE	0x600_0004			SDI buad rate prescaler
SDICARG	0x600_0008			SDI command argument
SDICCON	0x600_000C			SDI command control
SDICSTA	0x600_0010		R/(C)	SDI command status
SDIRSP0	0x600_0014		R	SDI response
SDIRSP1	0x600_0018			SDI response
SDIRSP2	0x600_001C			SDI response
SDIRSP3	0x600_0020			SDI response
SDIDTIMER	0x600_0024		R/W	SDI data / busy timer
SDIBSIZE	0x600_0028			SDI block size
SDIDCON	0x600_002C	W	R/W	SDI data control
SDIDCNT	0x600_0030		R	SDI data remain counter
SDIDSTA	0x600_0034		R/(C)	SDI data status
SDIFSTA	0x600_0038		R/(C)	SDI FIFO status
SDIIMSK	0x600_003C		R/W	SDI interrupt mask
SDIDAT0	0x600_0040	B, HW, W	R/W	SDI data0
SDIDAT1	0x600_0044	W		SDI data1
SDIDAT2	0x600_0048			SDI data2
SDIDAT3	0x600_004C			SDI data3

- Memory Stick

Register Name	Offset	Acc. Unit	Read/Write	Function
MSPRE	0x610_0000	W	R/W	Prescaler control
MSFINTCON	0x610_0004			FIFO interrupt control
TP_CMD	0x610_8000			Transfer protocol command
CTRL_STA	0x610_8004			Command and status
DAT_FIFO	0x610_8008			Data FIFO
INTCTRL_STA	0x610_800C			Interrupt control and status
INS_CON	0x610_8010			INS port control
ACMD_CON	0x610_8014			Auto command and polarity control
ATP_CMD	0x610_8018			Auto transfer protocol command

### System Management

- PLL Clock Control and Power Management

Register Name	Offset	Acc. Unit	Read/Write	Function
LOCKTIME	0x000_0000	W	R/W	PLL lock time counter
OSCWSET	0x000_0004			OSC settle-down wait time setting
MPLLCON	0x000_0010			MPLL configuration
UPLLCON	0x000_0014			UPLL configuration
CLKCON	0x000_0020			Clock generator control
CLKSRC	0x000_0024			Slow clock control
CLKDIVN	0x000_0028			Clock divider control
PWRMAN	0x000_0030			Power management
SOFTRESET	0x000_0038			Software reset

### IMPORTANT NOTES ABOUT S3C24A0A SPECIAL REGISTERS

1. The special registers have to be accessed by the recommended access unit.
2. All registers except ADC registers, RTC registers and UART registers must be read/written in word unit (32bit) at little/big endian.
3. It is very important that the ADC registers, RTC registers and UART registers be read/written by the specified access unit and the specified address. Moreover, one must carefully consider which endian mode is used.
4. W : 32-bit register, which must be accessed by LDR/STR or int type pointer (int \*).  
HW : 16-bit register, which must be accessed by LDRH/STRH or short int type pointer (short int \*).  
B : 8-bit register, which must be accessed by LDRB/STRB or char type pointer (char int \*).

# 2 SROM CONTROLLER

## OVERVIEW

S3C24A0A support external 16-bit bus for NAND Flash/ NOR Flash/ PROM/ SRAM external memory. It's not shared with SDRAM bus and support up to 3 Bank for one controller. From now on, we will refer this controller as SROM Controller.

Below figure show the Address Map configuration of S3C24A0A SROM Controller. S3C24A0A SROM Controller has 3 kinds of configuration. If user want to use NAND boot loader, it'll be selected the third configuration which stepping stone (SRAM 4KB) is on the 0x00000000. And If user want to use ROM type boot, it'll be selected the first or second configuration by selecting SFR (Special Function Register) of SROM Controller. In this case user can use NAND Flash Memory for other usage. At the first configuration, Stepping Stone is used just for buffer of any master.

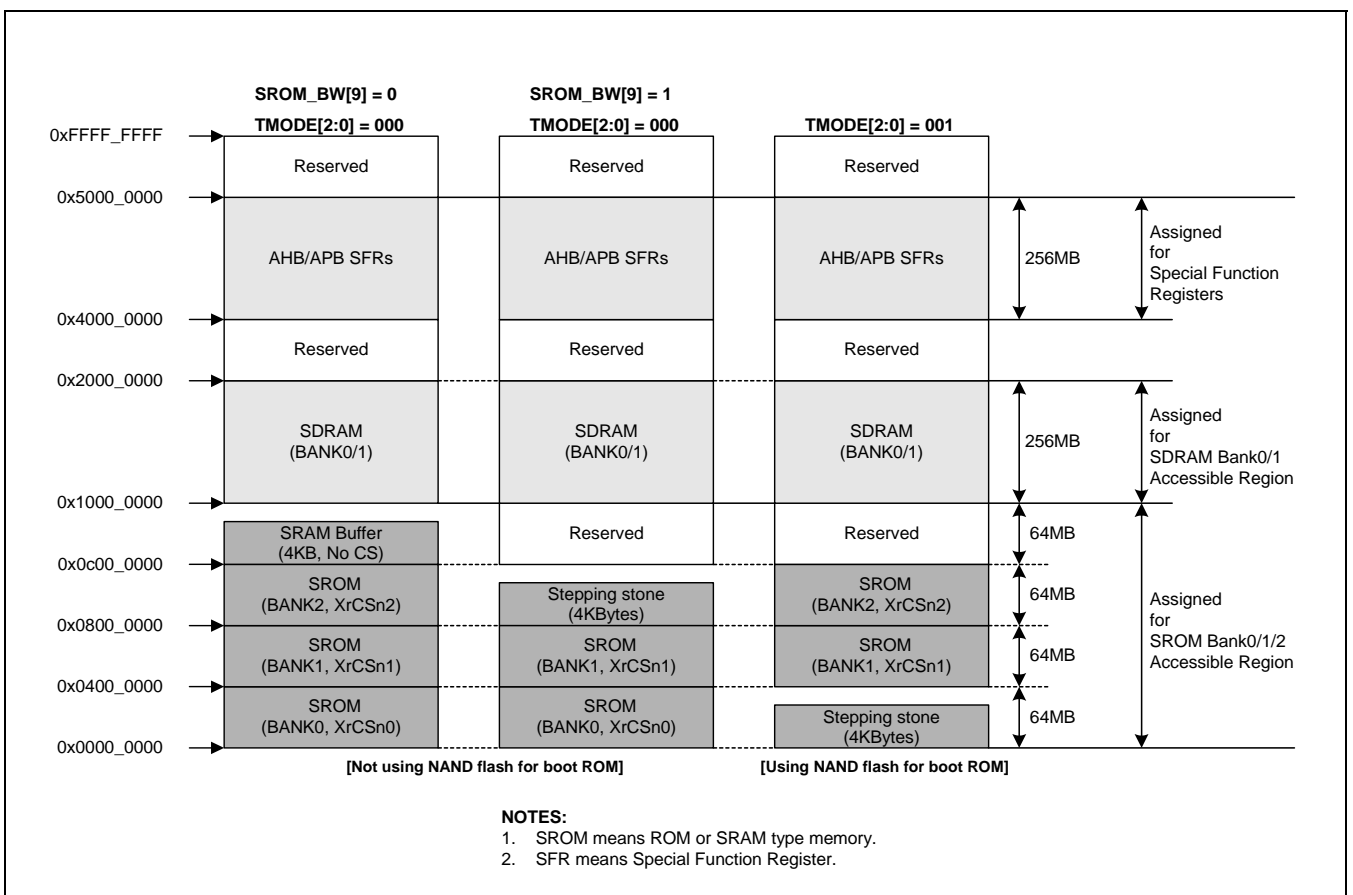

Figure 2-1. SROM Controller Address Mapping

## FEATURE

- Supports SRAM, various ROMs and NOR flash memory
- Supports only 8 or 16-bit data bus
- Address space : Up to 64MB per Bank
- Supports 3 banks (XrCSn[2:0])  
 Boot by NAND Flash Memory : XrCSn0's owner is not SROM Controller but NAND Controller.  
 Boot by other Memory (Nor Flash or ROM): XrCSn2's owner is either SROM Controller or NAND Controller  
 (User can choose it by setting SFR).
- Fixed memory bank start address
- External wait to extend the bus cycle
- Support byte, half-word and word access for external memory

## BLOCK DIAGRAM

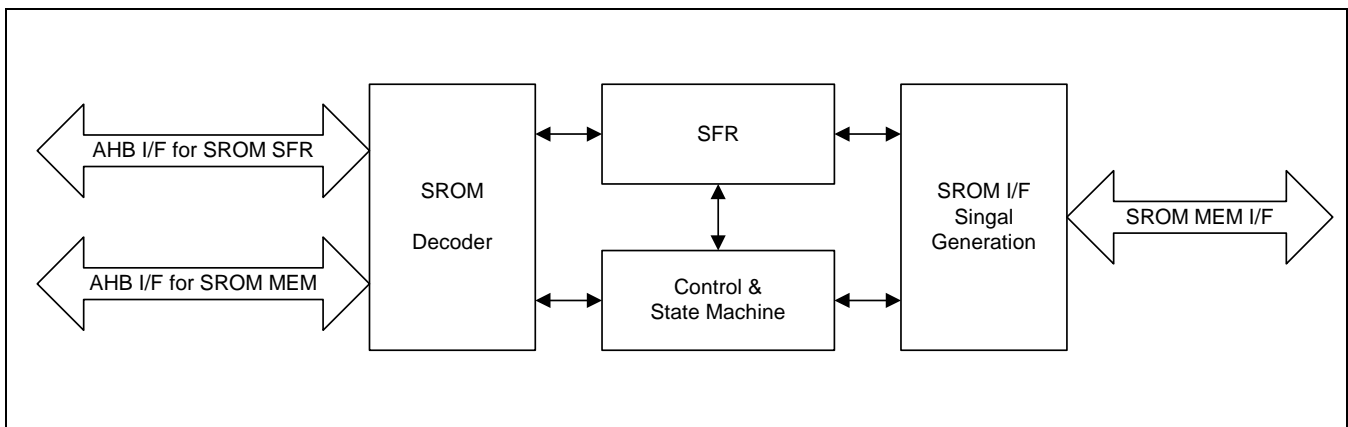
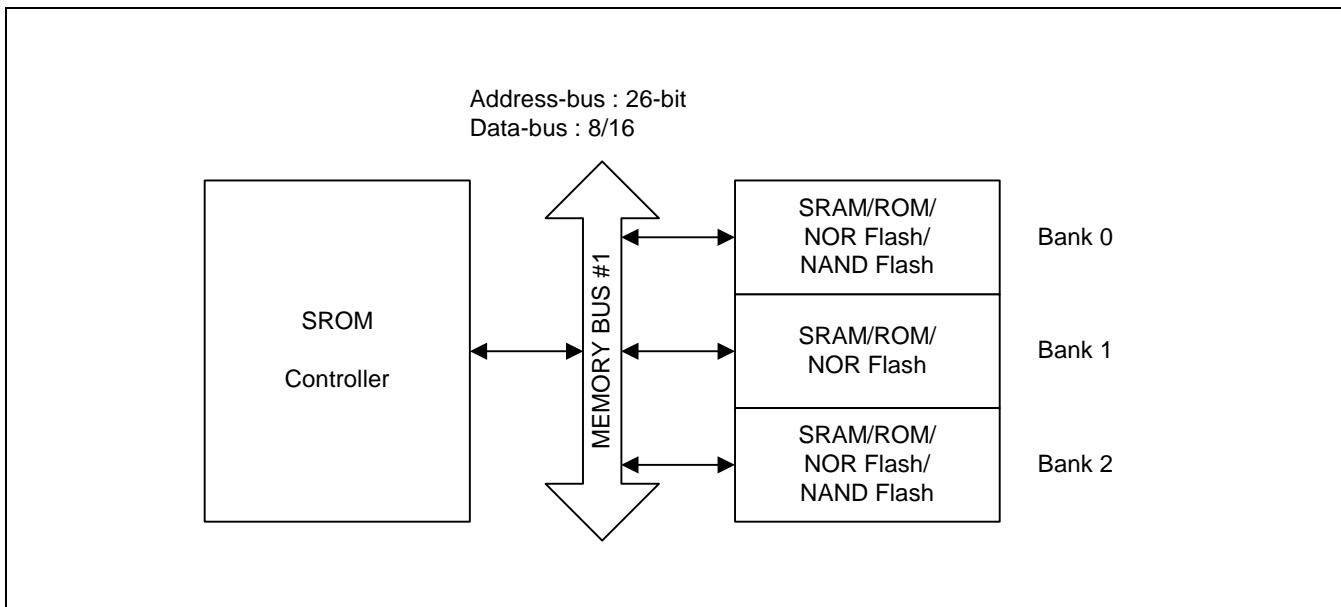

Figure 2-2. SROM Controller Block Diagram

**FUNCTION DESCRIPTION**

SROM Controller support SROM interface for Bank0 to Bank2. In case of NAND boot, SROM controller can't control Bank0 because of its mastership is on NAND Flash Controller. In case of ROM boot, as it mentioned before, it is possible that Bank2's master is NAND Flash Controller by setting of users.



**Figure 2-3. Memory Interface Block Diagram**



**XrWAITn Pin Operation**

If the WAIT corresponding to each memory bank is enabled, the XrOEn duration should be prolonged by the external XrWAITn pin while the memory bank is active. XrWAITn is checked from Tacc-1. The XrOEn will be deasserted at the next clock after sampling XrWAITn is high. The XrWEn signal have the same relation with XrOEn.

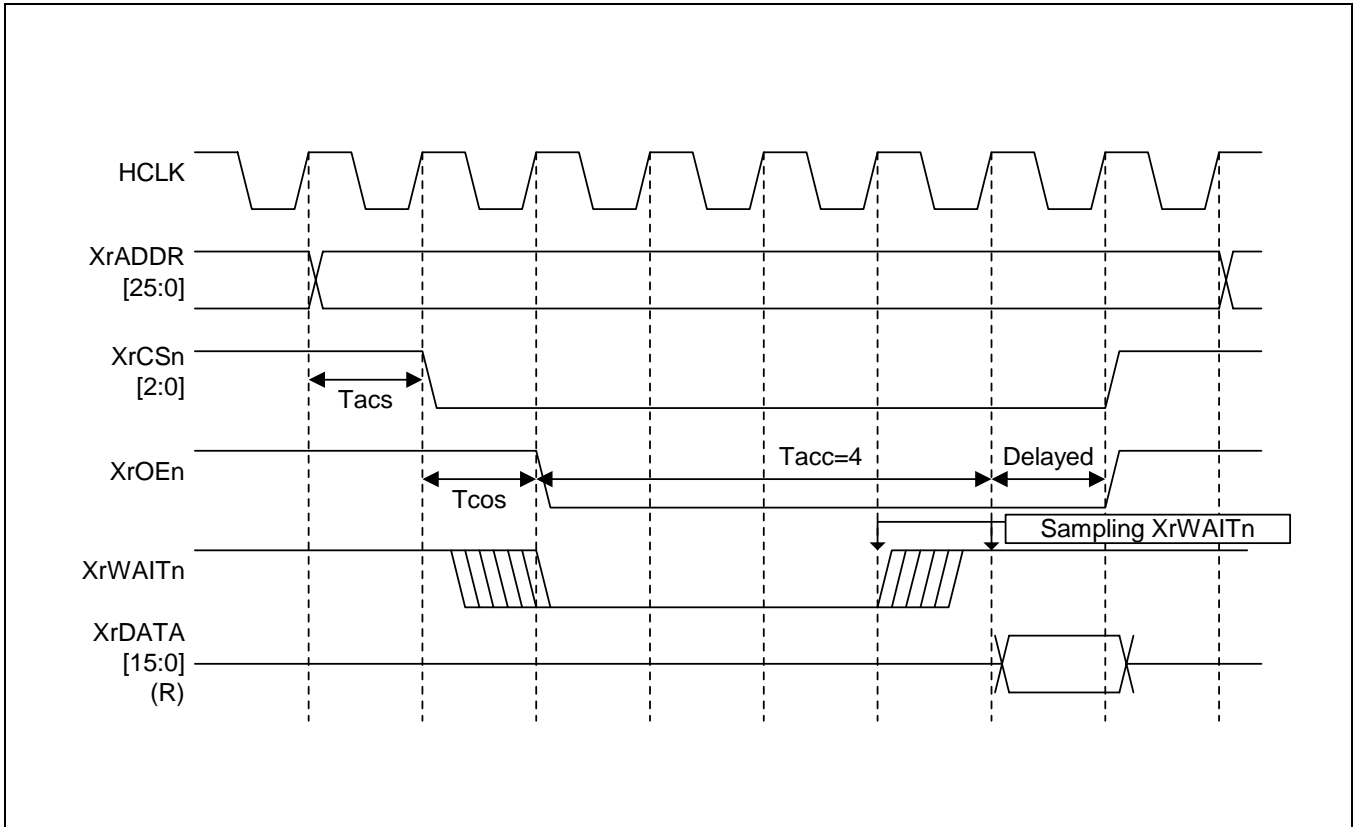

Figure 2-4. XrWAITn Pin Operation

PROGRAMMABLE ACCESS CYCLE WRITE TO READ WAVEFORM

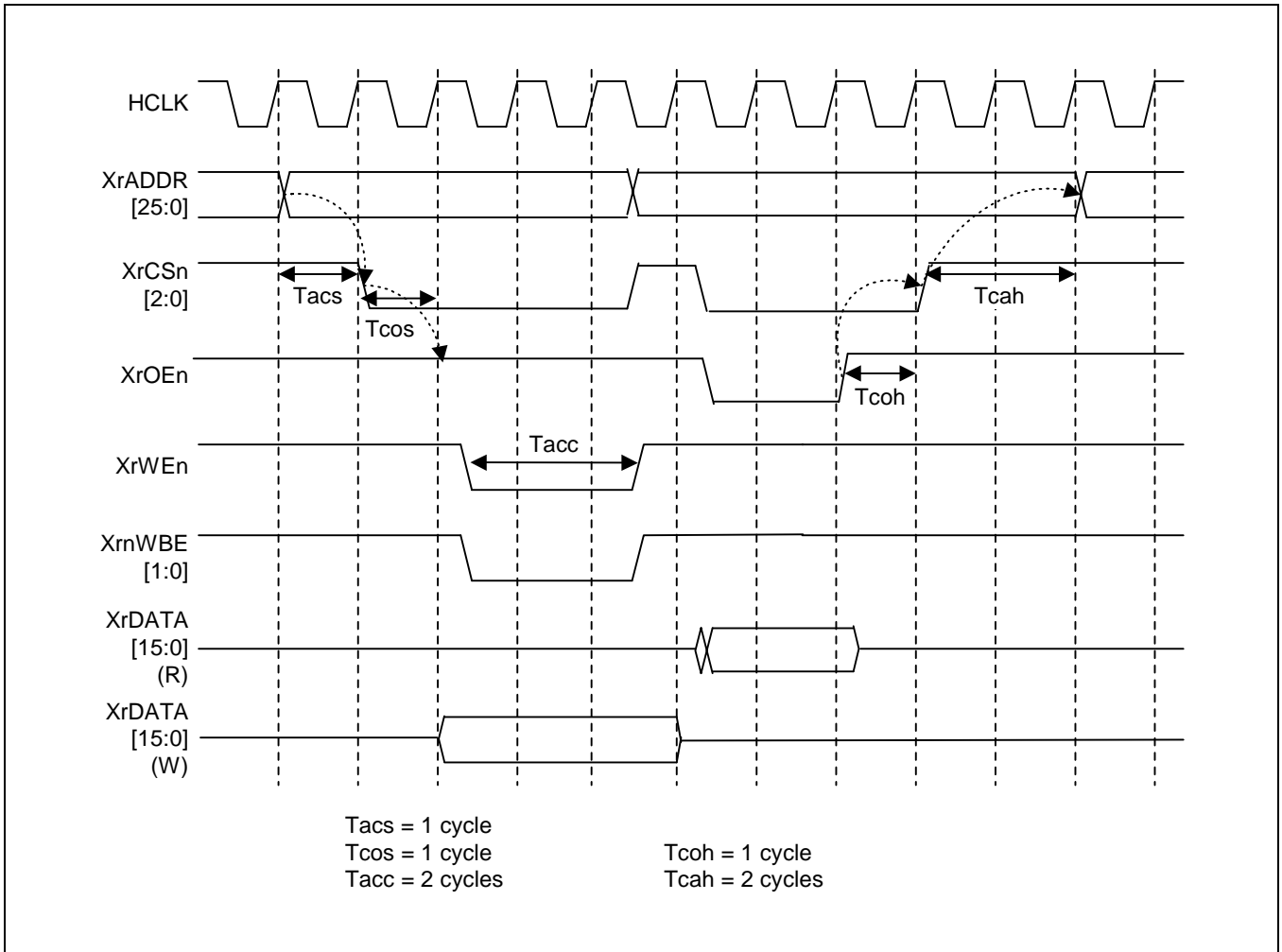

Figure 2-5. Programmable Access Cycle

## SPECIAL FUNCTION REGISTERS

## SROM BUS WIDTH &amp; WAIT CONTRL REGISTER(SROM\_BW)

Register	Address	R/W	Description	Reset Value
SROM_BW	0x40C20000	R/W	SROM Bus width & wait control	0x000x

SROM_BW	Bit	Description	Initial State
Reserved	[15:9]	Reserved	0x00
BankNum	[9]	0 = XrCSn2's owner is SROM Controller (In this case Stepping Stone is just used as 4KB SRAM buffer) 1 = XrCSn2's owner is NAND Flash Controller	0x00
ST2	[8]	This bit determines SRAM for using UB/LB for bank2 0 = Not using UB/LB (XrnWBE[1:0] is dedicated nWBE[1:0]) 1 = Using UB/LB (XrnWBE[1:0] is dedicated nBE[1:0])	0
WS2	[7]	This bit determines WAIT status for bank2 0 = WAIT disable                      1 = WAIT enable	0
DW2	[6]	Indicates data bus width for bank2 0 = 8-bit                                  1 = 16-bit	0
ST1	[5]	This bit determines SRAM for using UB/LB for bank1 0 = Not using UB/LB (XrnWBE[1:0] is dedicated nWBE[1:0]) 1 = Using UB/LB (XrnWBE[1:0] is dedicated nBE[1:0])	0
WS1	[4]	This bit determines WAIT status for bank1 0 = WAIT disable                      1 = WAIT enable	0
DW1	[3]	Indicates data bus width for bank1 0 = 8-bit                                  1 = 16-bit	0
ST0	[2]	This bit determines SRAM for using UB/LB for bank0 0 = Not using UB/LB (XrnWBE[1:0] is dedicated nWBE[1:0]) 1 = Using UB/LB (XrnWBE[1:0] is dedicated nBE[1:0])	0
WS0	[1]	This bit determines WAIT status for bank0 0 = WAIT disable                      1 = WAIT enable	0
DW0	[0]	Indicates data bus width for bank0 (read only) 0 = 8-bit                                  1 = 16-bit	H/W Set

\* DW0 is read only. The value is written by external configuration pin (XfNFBW)

## SRAM BANK CONTROL REGISTER (SRAM\_BC: XrCSn0 ~ XrCSn2)

Register	Address	R/W	Description	Reset Value
SRAM_BC0	0x40C20004	R/W	SRAM Bank0 control register	0x0700
SRAM_BC1	0x40C20008	R/W	SRAM Bank1 control register	0x0700
SRAM_BC2	0x40C2000C	R/W	SRAM Bank2 control register	0x0700

SRAM_BCn	Bit	Description	Initial State
Tacs	[15:14]	Address set-up before XrCSn[2:0] 00 = 0 clock            01 = 2 clock 10 = 4 clocks            11 = 8 clocks	00
Tcos	[13:12]	Chip selection set-up XrOEn 00 = 0 clock            01 = 2 clock 10 = 4 clocks            11 = 8 clocks	00
Reserved	[11]	Reserved	0
Tacc	[10:8]	Access cycle 000 = 2 clock            001 = 3 clocks 010 = 4 clocks            011 = 10 clocks 100 = 12 clocks            101 = 14 clocks 110 = 16 clock            111 = 20 clocks	111
Tcoh	[7:6]	Chip selection hold on XrOEn 00 = 0 clock            01 = 2 clock 10 = 4 clocks            11 = 8 clocks	00
Tcah	[5:4]	Address holding time after XrCSn[2:0] 00 = 0 clock            01 = 2 clock 10 = 4 clocks            11 = 8 clocks	00
Reserved	[3:0]	Reserved	0000

# 3 SDRAM CONTROLLER

## OVERVIEW

The S3C24A0A SDRAM Controller has the following features:

- SDRAM
  - Supports 16-bit or 32-bit data bus
  - Supports 2 banks: XpCSN[1:0]
  - 16-bit Refresh Timer
  - Self Refresh Mode
  - Programmable CAS Latency
  - Provide Write buffer (4word size x2)
  - Provide long burst(INCR8, 16 & WRAP8, 16) transfer
  - Provide Power Down Mode
  - Support mobile SDRAM
  - Support extended MRS set (EMRS)
  - DS, TSCR, PASR

## SELECTION OF SDRAM

We recommend to select one of the SDRAM configurations in Table 3-1. And, each two banks should have same bus width.

**Table 3-1. Supported SDRAM Configuration**

Total Size	Bus Width	Base Component	Memory Configuration	Bank Address
4MB	x32	16Mb	(512Kbit x 16bit x 2Bank) x 2ea	A13
8MB		64Mb	(512K x 32 x 4) x 1	A[14:13]
		16Mb	(1M x 8 x 2) x 4	A13
16MB		128Mb	(1M x 32 x 4) x 1	A[14:13]
		64Mb	(1M x 16 x 4) x 2	A[14:13]
32MB		256Mb	(2M x 32 x 4) x 1	A[14:13]
		128Mb	(2M x 16 x 4) x 2	A[14:13]
		64Mb	(2M x 8 x 4) x 4	A[14:13]
64MB		256Mb	(4M x 16 x 4) x 2	A[14:13]
		128Mb	(4M x 8 x 4) x 4	A[14:13]
		512Mb	(4M x 32 x 4) x 1	A[14:13]
128MB		256Mb	(8M x 8 x 4) x 4	A[14:13]
	512Mb	(8M x 16 x 4) x 2	A[14:13]	
2MB	x16	16Mb	(512K x 16 x 2) x 1	A13
4MB		16Mb	(1M x 8 x 2) x 2	A13
8MB		64Mb	(1M x 16 x 4) x 1	A[14:13]
16MB		128Mb	(2M x 16 x 4) x 1	A[14:13]
		64Mb	(2M x 8 x 4) x 2	A[14:13]
32MB		256Mb	(4M x 16 x 4) x 1	A[14:13]
		128Mb	(4M x 8 x 4) x 2	A[14:13]
64MB		256Mb	(8M x 8 x 4) x 2	A[14:13]
		512Mb	(8M x 16 x 4) x 1	A[14:13]

## SELF REFRESH

The S3C24A0A provides the auto refresh and self refresh command to sustain the contents of SDRAM. The auto refresh is issued to SDRAM periodically when refresh timer is expired. The self refresh is entered and exited by request of on-chip power manager.

**SDRAM INITIALIZATION SEQUENCE**

On power-on reset, software must initialize the memory controller and each of the SDRAM connected to the controller. Refer to the SDRAM data sheet for the start up procedure, and examples sequence is given below:

1. Wait 200us to allow SDRAM power and clock stabilize.
2. Program the INIT[1:0] to '01b'. This automatically issues a PALL(pre-charge all) command to the SDRAM.
3. Write '0x20' into the refresh timer register. This provides a refresh cycle every 32-clock cycles.
4. Wait for a time period equivalent to 128-clock cycles (4 refresh cycles).
5. Program the normal operational value into the refresh timer..
6. Program the configuration registers to their normal operation values.
7. Program the INIT[1:0] to '10b'. This automatically issues a MRS command to the SDRAM.
8. Mobile only Program the INIT[1:0] to '11b'. This automatically issues a EMRS command to the SDRAM.
9. Program the INIT[1:0] to '00b'. The controller enters the normal mode.
10. The SDRAM is now ready for normal operation.

**NOTE**

If you issue MRS after issuing EMRS, EMRS value will be reset. So you have to issue EMRS after issuing MRS.

SDRAM Memory Interface Examples

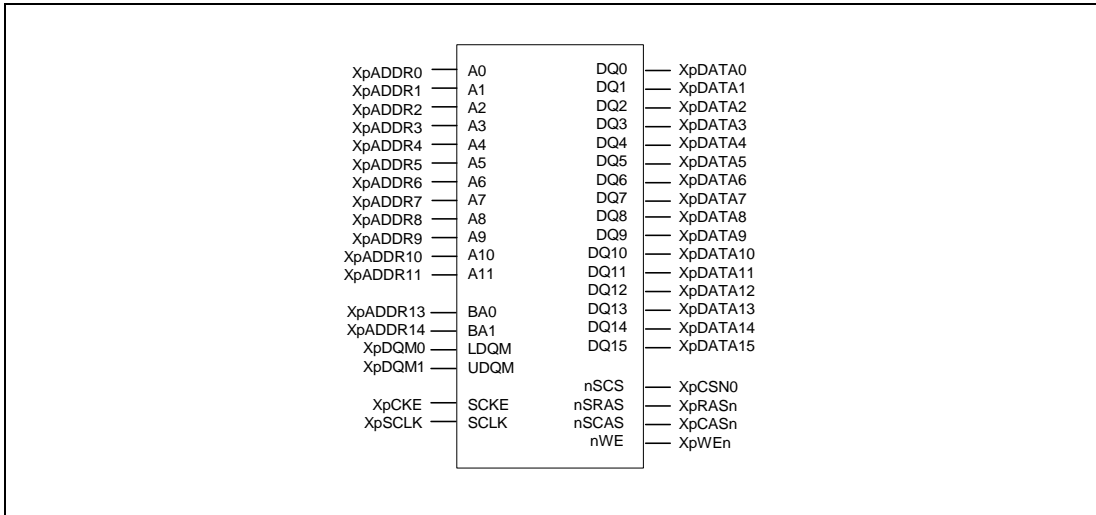

Figure 3-1. Memory Interface with 16-bit SDRAM (4Mx16, 4banks)

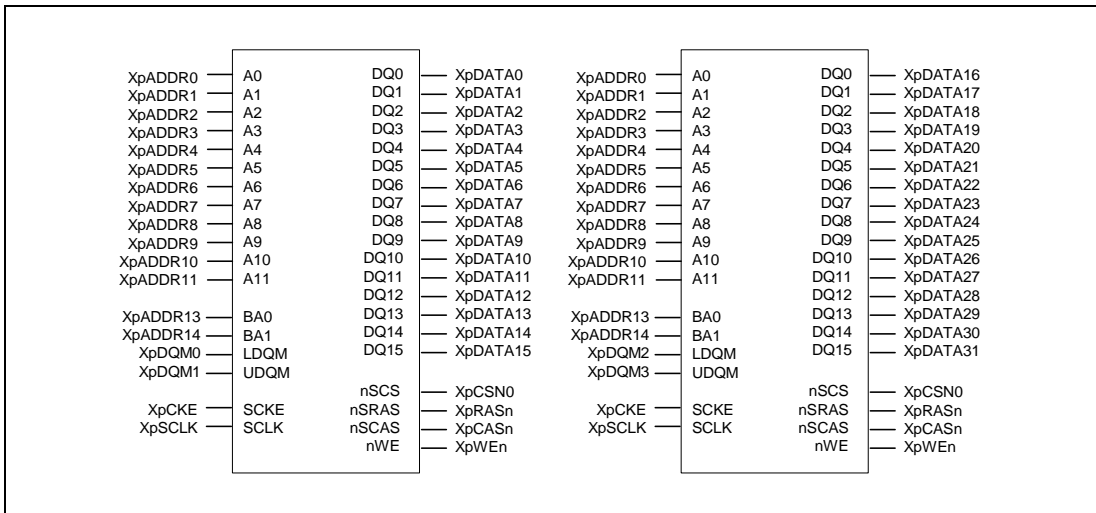

Figure 3-2. Memory Interface with 16-bit SDRAM (4Mx16 x 2ea, 4banks)



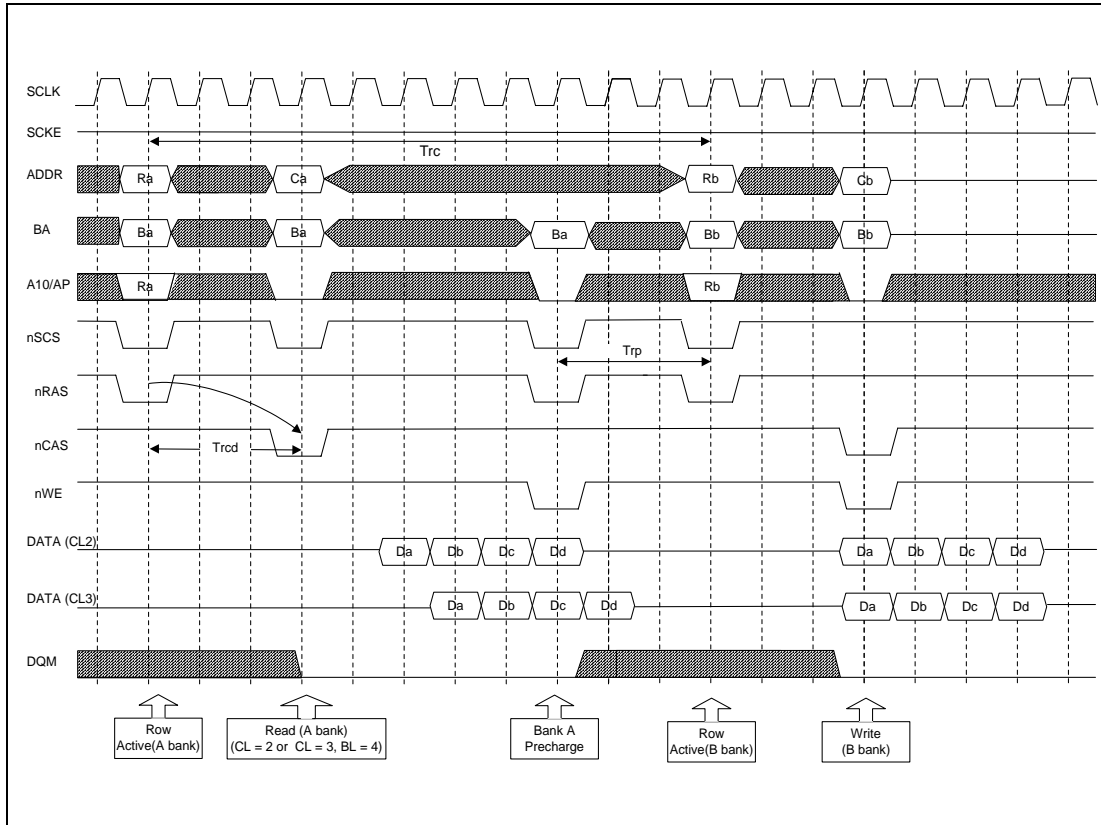

Figure 3-3. SDRAM Timing Diagram

## SDRAM CONFIGURATION REGISTER

Register	Address	R/W	Description	Reset Value
SDRAM_BANKCFG	0x40C40000	R/W	Port 1 SDRAM configuration register	0x9f0c

SDRAM_BANKCFG	Bit	Description	Initial State
DS	[30:29]	Driver Strength Control 00 = Full            01 = Half 10 = Weak            11 = RFU <b>Note:</b> DS bit fields are only for mobile SDRAM.	00b
TCSR	[28:27]	Temperature compensated self refresh control 00 = 46 ~ 70 °C    01 = 16 ~ 45 °C 10 = -25 ~ 15 °C   11 = 71 ~ 85 °C <b>Note:</b> TCSR bit fields are only for mobile SDRAM.	00b
PASR	[26:24]	Partial array self refresh control 000 = 4banks    001 = 2banks    010 = 1banks 011 = Reserved   100 = Reserved   101 = Reserved 110 = Reserved   111 = Reserved <b>Note:</b> PASR bit fields are only for mobile SDRAM.	00b
Reserved	[23:21]	Reserved	
PWRDN	[20]	0 = Not support SDRAM power down control 1 = Support SDRAM power down control	0
Tras	[19:16]	Row active time 0000=1-clock   0001=2-clock   0010=3-clock   0011=4-clock 0100=5-clock   0101=6-clock   0110=7-clock   0111=8-clock 1000=9-clock   1001=10-clock   1010=11-clock   1011=12-clock 1100=13-clock   1101=14-clock   1110=15-clock   1111=16-clock	1001b
Trc	[15:12]	Row cycle time 0000=1-clock   0001=2-clock   0010=3-clock   0011=4-clock 0100=5-clock   0101=6-clock   0110=7-clock   0111=8-clock 1000=9-clock   1001=10-clock   1010=11-clock   1011=12-clock 1100=13-clock   1101=14-clock   1110=15-clock   1111=16-clock	1001b
Trcd	[11:10]	RAS to CAS delay 00 = 1-clock    01 = 2-clock    10 = 3-clock    11 = 4-clock	11b
Trp	[9:8]	Row pre-charge time 00 = 1-clock    01 = 2-clock    10 = 3-clock    11 = 4-clock	11b
DENSITY1	[7:6]	SDRAM base component density of bank 1 00 = 16Mbit    01 = 64Mbit 10 = 128Mbit   11 = 256Mbit and 512Mbit	00b
DENSITY0	[5:4]	SDRAM base component density of bank 0 00 = 16Mbit    01 = 64Mbit 10 = 128Mbit   11 = 256Mbit and 512Mbit	00b

## SDRAM CONFIGURATION REGISTER (Continued)

SDRAM_BANKCFG	Bit	Description	Initial State
CL	[3:2]	CAS latency 00 = Reserved 01 = 1-clock 10 = 2-clock 11 = 3-clock	11b
P	[1]	Auto pre-charge control 0 = enable auto pre-charge 1 = disable auto pre-charge	10b
DW	[0]	Determine data bus width 0 = 32-bit 1 = 16-bit	00b

**NOTE:** SDRAM\_BANKCFG register should not be written when the SDRAM controller is busy. The controller status bit, BUSY in SDRAM\_BANKCON register, can be used to check if the controller is idle.

## SDRAM CONTROL REGISTER

Register	Address	R/W	Description	Reset Value
SDRAM_BANKCON	0x40C40004	R/W	Port 1 SDRAM control register	0x00

SDRAM_BANKCON	Bit	Description	Initial State
Reserved	[31:4]	Reserved	0b
BUSY	[3]	SDRAM controller status bit (read only) 0 = IDLE 1 = BUSY	0b
WBUF	[2]	Write buffer control 0 = Disable 1 = Enable <b>Note:</b> Write buffer mentioned above is in SDRAM controller. If write buffer is disabled, data is written to the external SDRAM memory immediately. If write buffer is enabled, data is flushed to the external SDRAM memory when write buffer is full.	0b
INIT	[1:0]	SDRAM initialization control 00 = Normal operation 01 = Issue PALL command 10 = Issue MRS command 11 = Issue EMRS command <b>Note:</b> EMRS command is only for mobile SDRAM.	00b

## REFRESH CONTROL REGISTER

Register	Address	R/W	Description	Reset Value
SDRAM_REFRESH	0x40C40008	R/W	SDRAM refresh control register	0x0020

SDRAM_REFRESH	Bit	Description	Initial State
REFCYC	[15:0]	SDRAM refresh cycle. <b>Example:</b> Refresh period is 15.6us, and HCLK is 66MHz. The value of REFCYC is as follows: $REFCYC = 15.6 \times 10^{-6} \times 66 \times 10^6 = 1029$	100000b

# 4 NAND FLASH CONTROLLER

## OVERVIEW

In recent times NOR flash memory gets high in price while an SDRAM and a NAND flash memory get moderate, motivating some users to execute the boot code on a NAND flash and execute the main code on an SDRAM.

S3C24A0A boot code can be executed on an external NAND flash memory. In order to support NAND flash boot loader, the S3C24A0A is equipped with an internal SRAM buffer called 'Steppingstone'. When booting, the first 4 KBytes of the NAND flash memory will be loaded into Steppingstone and the boot code loaded into Steppingstone will be executed.

Generally, the boot code will copy NAND flash content to SDRAM. Using hardware ECC, the NAND flash data validity will be checked. Upon the completion of the copy, the main program will be executed on the SDRAM.

## FEATURES

- Support up to 2Gbit Nand Flash Memory.
- Support 256/512/1K/2K byte page, 3,4 or 5 address cycle NAND Flash memory
- Auto boot mode: The boot code is transferred into Steppingstone during reset. After the transfer, the boot code will be executed on the Steppingstone.
- Auto load mode: Support automatically one or more page load from Flash Memory to Steppingstone
- Auto store mode: Support automatically one page store to Flash Memory from Steppingstone
- Software mode: User can directly access NAND flash memory, for example this feature can be used in read/erase/program NAND flash memory
- Memory bus interface: 8 / 16-bit NAND flash memory interface bus
- Hardware ECC generation, detection and indication (Software correction)
- SFR I/F: Support Little Endian Mode, Byte/half word/word access
- SteppingStone I/F: Support Little Endian, Byte/half word/word access
- The Steppingstone 4-KB internal SRAM buffer can be used for another purpose after NAND flash booting



## PIN CONFIGURATION

The following is the configuration of NAND Flash Controller of S3C24A0A. Users can select configuration of NAND Flash Memory according to the table below. There are some differences between conventional NAND Flash Memory and New Advance Flash Memory. So users have to select the configuration properly.

**Table 4-1. Advance NAND Flash Controller Configuration (word means 16-bit in this table)**

Advance Flash	Page Size	Bus Width	Real Page Size	Organization
0	0	0	256Byte	–
		1	256Word	16bit × 1
	1	0	512Byte	8bit × 1
		1	1KByte	8bit × 2
1	0	0	1KByte	–
		1	1KWord	16bit × 1
	1	0	2KByte	8bit × 1
		1	4KByte	8bit × 2

Advance Flash	Address Cycle	Real Cycle
0	0	3cycle (256M)
	1	4cycle (512M)
1	0	4cycle (1G)
	1	5cycle (2G)

**BLOCK DIAGRAM**

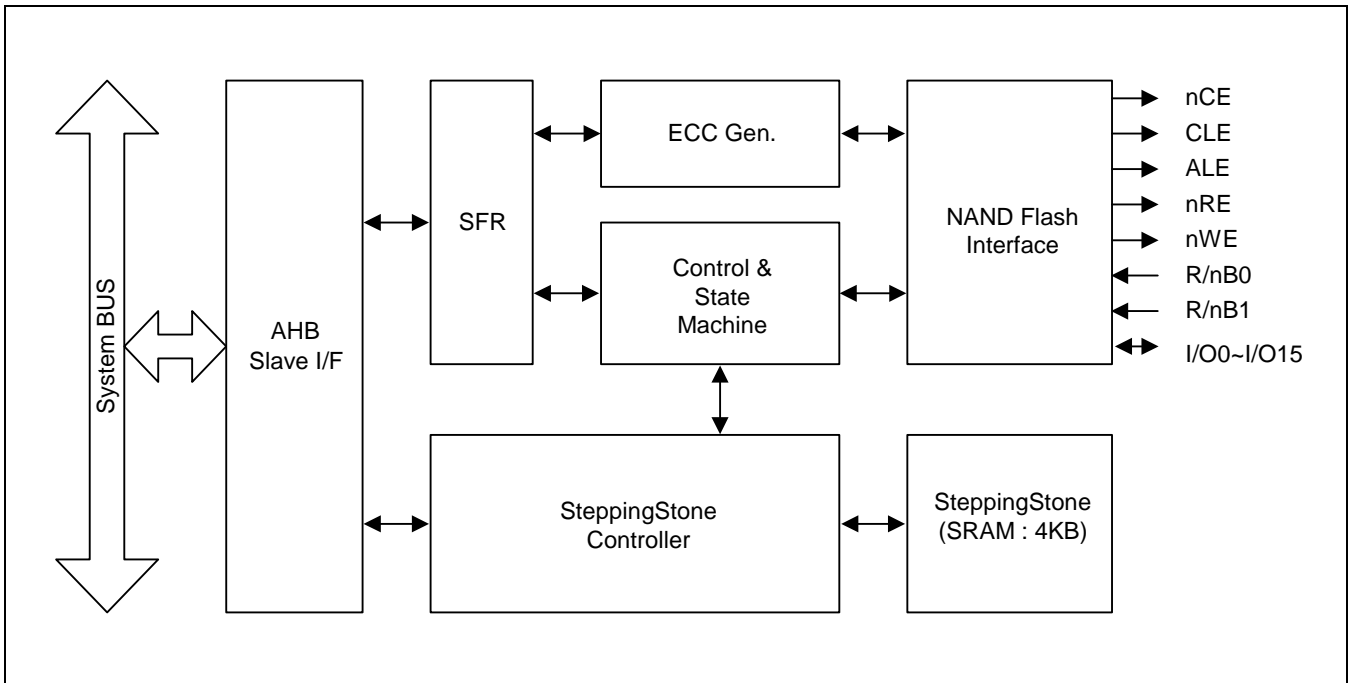

**Figure 4-1. NAND Flash Controller Block Diagram**

## BOOT LOADER FUNCTION

When power-on or system reset is occurred, the NAND Flash controller loads automatically the 4-KBytes boot loader codes. After loading the boot loader codes, the boot loader code is executed on the steppingstone.

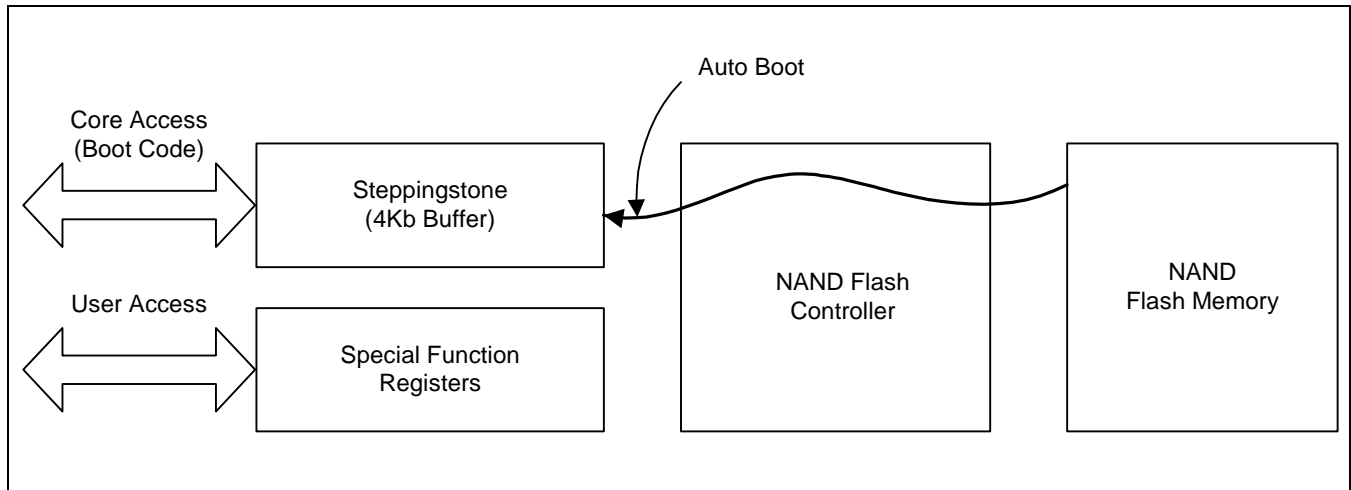
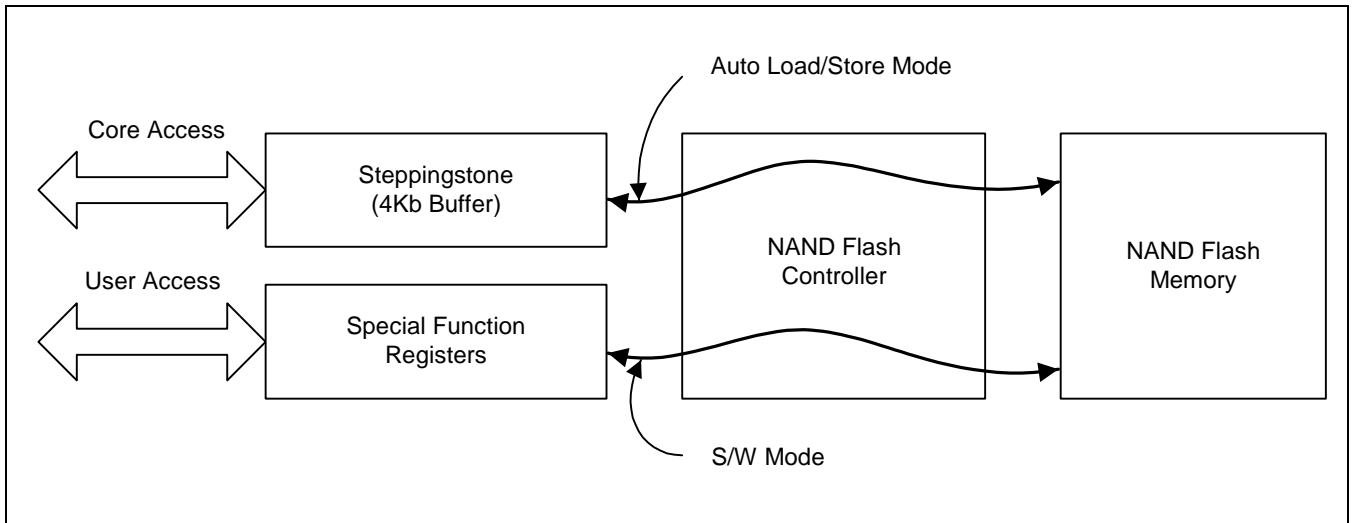

Figure 4-2. NAND Flash Controller Boot Loader Block Diagram



**OPERATION MODE**



**Figure 4-3. NAND Flash Controller Operation Mode Block Diagram**

Figure 4-3 describes all operation modes of the NAND Flash controller. The NAND Flash controller controls the Auto load and store page(s) by using the steppingstone automatically in auto load or store mode. In software mode, you can access the NAND Flash Memory directly using the command, address and data register.

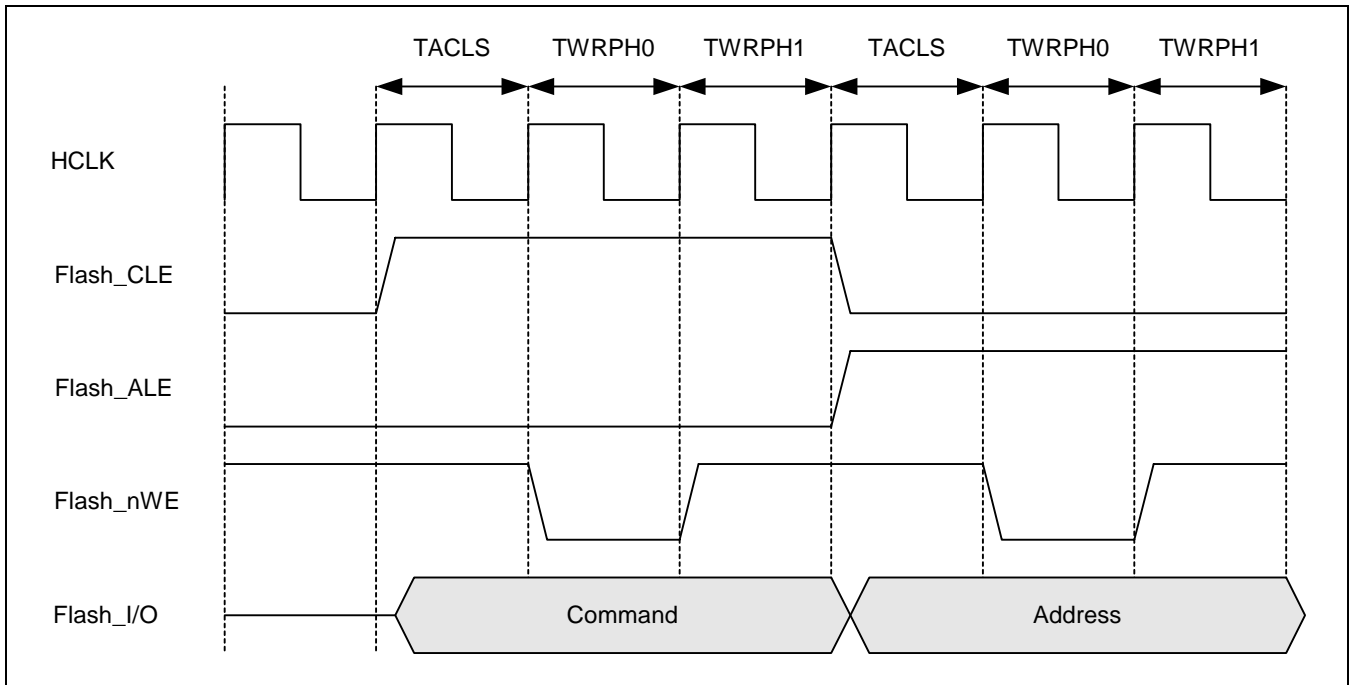

**Figure 4-4. Auto Mode Timing Diagram (TACLS = 1, TWRPH0 = 0, TWRPH1 = 0)**

## AUTO LOAD MODE

Auto load function supports automatically load the page(s) of the NAND Flash Memory to steppingstone up to 4KBytes. You can specify the load start address of the steppingstone and how many pages are loaded.

### AUTO LOAD PROGRAMMING GUIDE

1. Set command (read command), address (of the page you read), and configuration and control value.
2. Set the MODE bit of the controller register to 0b01(auto load start)
3. Once you set the MODE bit to auto mode, the NAND Flash controller automatically load the page(s) you specify from the NAND Flash Memory.
4. When auto loading is completed, the MODE is reset to 0b00 and the LoadDone bit of the status register is set. Also you can know this event by using auto load done interrupt

#### NOTE

The NAND Flash Controller only load main area data (256 or 512 bytes), not the spare area data. So you need to access the spare area, you have to use the software mode (refer to the Software mode).

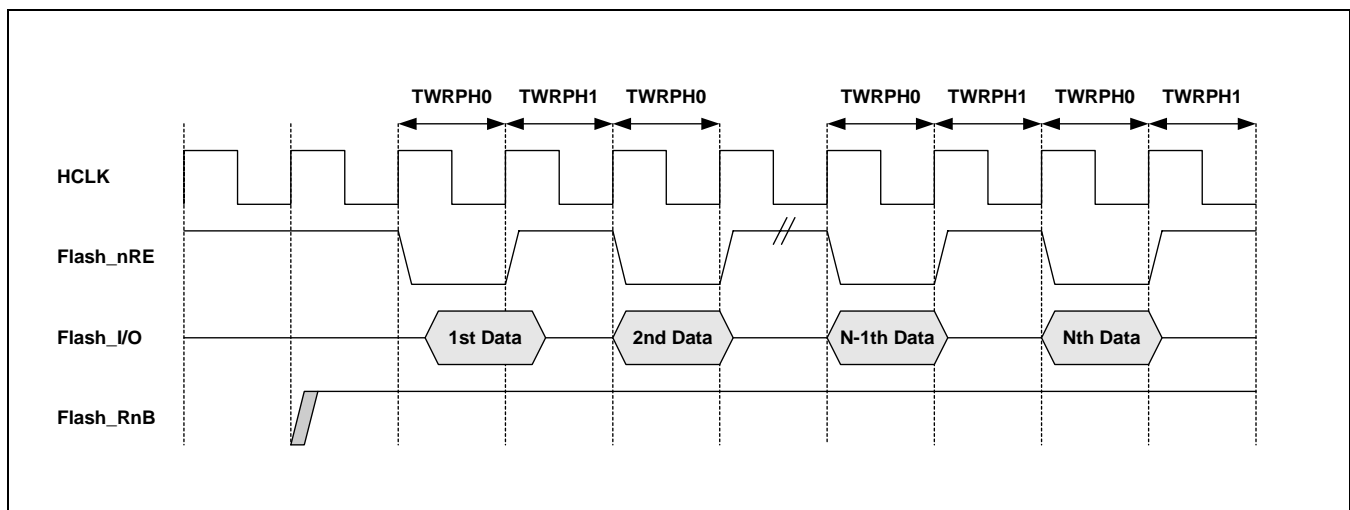

Figure 4-5. NAND Flash Controller Auto Load Timing Diagram (TWRPH0 = 0, TWRPH1 = 0)

## AUTO STORE MODE

Auto store function supports automatically store a page from the steppingstone to the NAND Flash Memory. You can specify the store start address of the steppingstone. In auto store mode, only one page store is supported.

### AUTO STORE PROGRAMMING GUIDE

1. Set command (1<sup>st</sup> program command), address (of the page you store), configuration and control value.
2. Set MODE bit of the controller register to 0b10(auto store start)
3. Once you set MODE bit to the auto store mode, the NAND Flash controller automatically store a page to the NAND Flash Memory.
4. When auto storing is completed, the MODE is reset to 0b00 and the StoreDone bit of the status register is set. Also you can know this event by using auto store done interrupt

### NOTE

The NAND Flash Controller can only store main area data (256 or 512 bytes), not the spare area data. So you need to access the spare area, you have to use the software mode (refer to the Software mode).

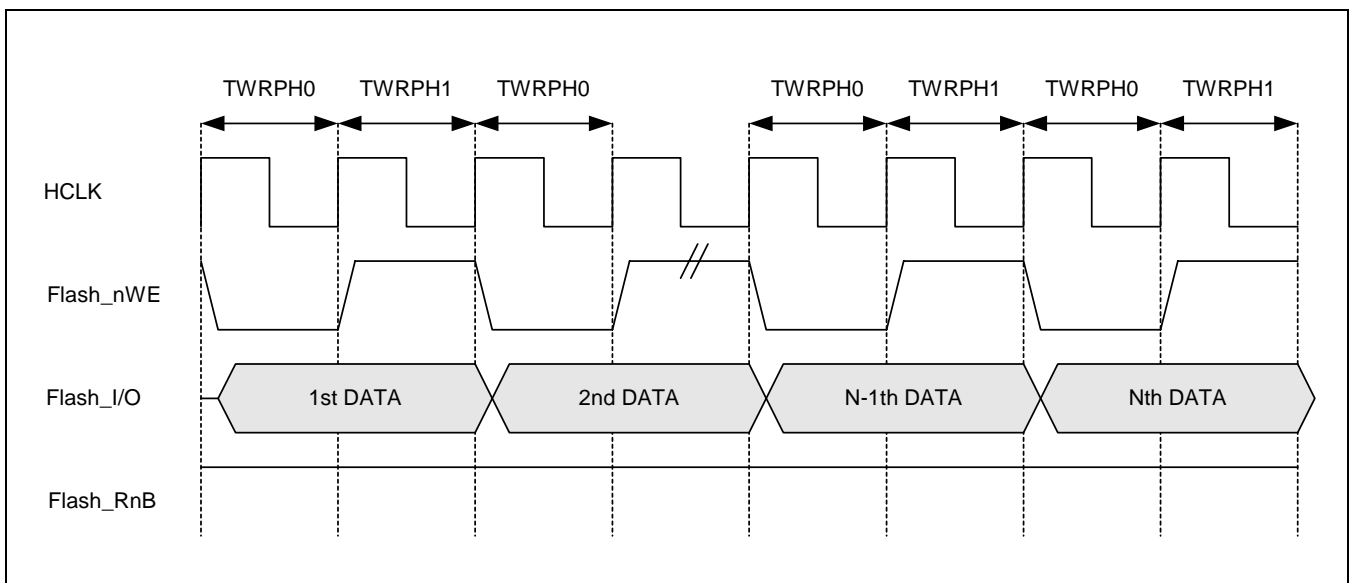

Figure 4-6. NAND Flash Controller Auto Store Timing Diagram (TWRPH0 = 0, TWRPH1 = 0)

## SOFTWARE MODE

In the software mode, you can fully access the NAND Flash controller. The NAND Flash Controller supports direct access interface with the NAND Flash Controller.

1. The writing to the command register = the NAND Flash Memory command cycle
2. The writing to the address register = the NAND Flash Memory the address cycle
3. The writing to the data register = write data to the NAND Flash Memory (write cycle)
4. The reading from the data register = read data from the NAND Flash Memory (read cycle)
5. The reading main ECC registers and Spare ECC registers = read data from the NAND Flash Memory

### NOTE

In the software mode, you have check the Flash\_RnB status input pin by using polling or interrupt.

## STEPPING STONE (4K-BYTE SRAM)

The NAND Flash controller uses Steppingstone as the buffer in the auto load and store mode. Also you can use this area for another purpose, if you don't use auto load and store function.

For the best performance, if you need to move the content of the NAND Flash Memory to SDRAM, We recommend that you use DMA burst transfer(source address : Steppingstone, destination address : SDRAM). The NAND Flash Controller supports that the NAND Flash controller and other masters can access the steppingstone concurrently.

For example, 1K-byte of the steppingstone area have valid data, and the NAND Flash Controller is moving data from the NAND Flash Memory to Steppingstone(Area : 1K ~ 4K-Byte). You can move 0 ~ 1K-Byte data to the other memory area using DMA burst transfer(DMA burst tranfer is the best solution for the high speed).

## ERROR CORRECTION CODE

NAND Flash controller has four ECC (Error Correction Code) modules. The two ECC modules (one for data[7:0] and the other for data[15:8]) can be used for (up to) 2048 bytes ECC Parity code generation, and the others(one for data[7:0] and the other for data[15:8]) can be used for (up to) 16 bytes ECC Parity code generation.

- 28bit ECC Parity Code = 22bit Line parity + 6bit Column Parity
- 14bit ECC Parity Code = 8bit Line parity + 6bit Column Parity

**Table 4-2. 2K Byte Main Area ECC Parity Code Assignment Table**

	DATA7	DATA6	DATA5	DATA4	DATA3	DATA2	DATA1	DATA0
<b>ECC0</b>	P64	P64'	P32	P32'	P16	P16'	P8	P8'
<b>ECC1</b>	P1024	P1024'	P512	P512'	P256	P256'	P128	P128'
<b>ECC2</b>	P4	P4'	P2	P2'	P1	P1'	P2048	P2048'
<b>ECC3</b>	P8192	P8192'	P4096	P4096'	0	0	0	0

**Table 4-3. 16 Byte SPARE AREA ECC Parity Code Assignment Table**

	DATA7	DATA6	DATA5	DATA4	DATA3	DATA2	DATA1	DATA0
<b>ECC0</b>	P16	P16'	P8	P8'	P4	P4'	P2	P2'
<b>ECC1</b>	P1	P1'	P64	P64'	P32	P32'	0	0

**ECC MODULE FEATURES**

1. In auto load & auto store mode, ECC module generates automatically ECC parity code.
2. In software mode, ECC generation is controlled by the ECC Lock (MainECCLock, SpareECCLock) bit of the Control register.

**ECC PROGRAMMING GUIDE**

1. In auto store mode  
In auto store mode, ECC module generates automatically ECC parity code for main data (256 or 512 bytes), not for spare area data. After auto store is completed, you may need to recode the ECC parity code generated to the spare area of NAND Flash Memory. In this case, you just do read the first, second and third ECC status registers and writes to the spare area.
2. In auto load mode  
In auto load mode, ECC module also generates automatically ECC parity code for main data. After auto load is completed, you may need to check that the content of NAND flash memory have no bit error. In this case, you just do read the first, second and third ECC value from the spare area through the main data area ecc0, ecc1 and ecc2 register.
3. In Software mode
  - A. In software mode, ECC module generates ECC parity code for all read / write data. So you have to reset ECC value before read or write data using the InitECC bit of the Control register and have to set the MainECCLock bit of the control register to '0'. MainECCLock and SpareECCLock bit control whether ECC Parity code is generated or not.
  - B. After you reset ECC parity code. Whenever you read or write data, the ECC modules generate ECC parity code on this data.
  - C. After you finished read or write all page data. Set the MainECCLock bit to '1'. ECC Parity code is locked and the value of the ECC status register isn't changed. From now as described in auto store & load mode, you can use these values to record to the spare area or check the bit error.

### NAND FLASH MEMORY CONFIGURATIONS

Figure 4-7 ~ Figure 4-9 describe the configuration of NAND flash memory. If you use NAND flash memory as a boot memory, you can use one of these memory configurations. But if you use NAND flash memory as an I/O memory not a boot memory, you have to connect nGCS[0] signal to Boot ROM memory. In these cases you can use NF\_RnB[1] signal which is used as a selection signal of NAND flash memory. Also the NF\_RnB[1] is internally fixed 'H'.

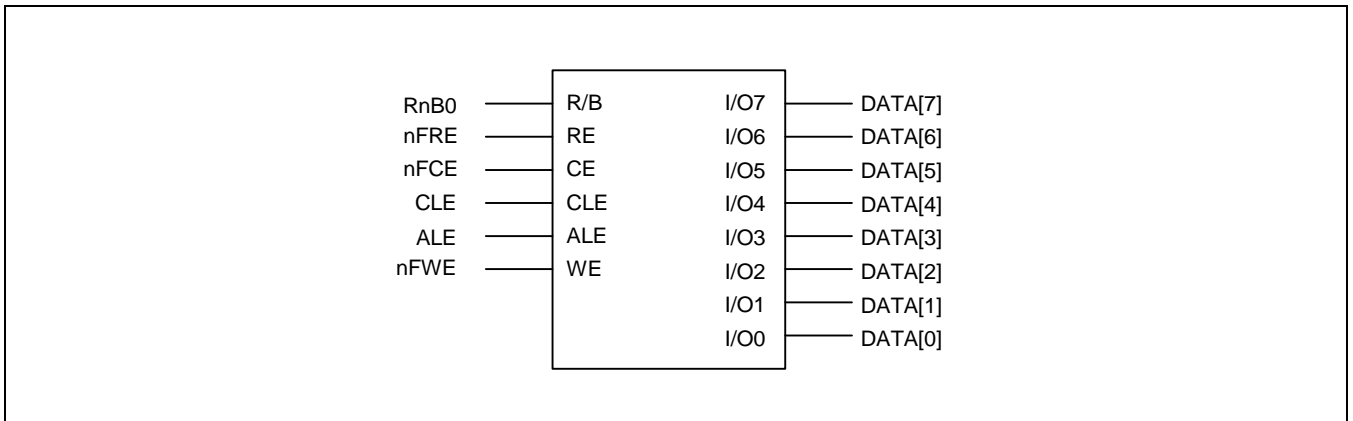

Figure 4-7. 8-bit NAND Flash Memory Interface

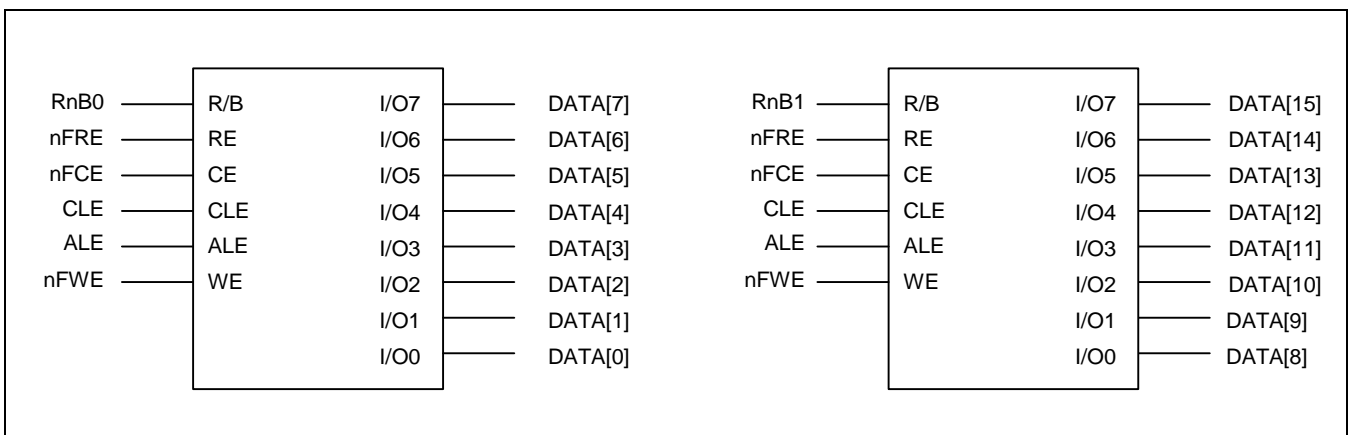

Figure 4-8. Two 8-bit NAND Flash Memory Interface

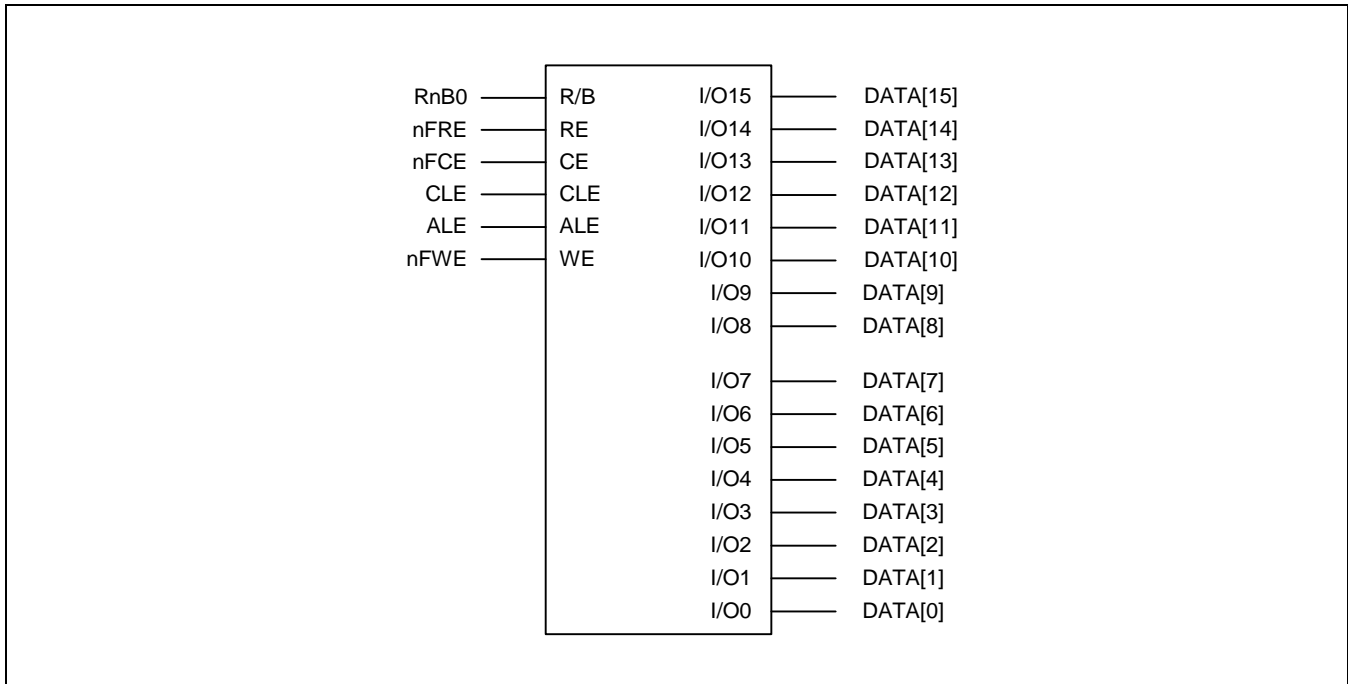

Figure 4-9. 16-bit NAND Flash Memory Interface



## NAND FLASH CONTROLLER SPECIAL REGISTERS

### CONFIGURATION REGISTER

Register	Address	R/W	Description	Reset Value
NFCNF	0x40C00000	R/W	NAND flash configuration register	0x00XF100X

NFCNF	Bit	Description	Initial State
Reserved	[23]	Reserved	00
Advance Flash	[22]	Supports 1G & 2G Advance Flash Memory This bit indicates whether external memory is new version or not	H/W Set
TCEH	[21:16]	nCE High Hold Time to break the sequential read cycle used only boot loader & auto load function Duration = HCLK × (TCEH+1)	0x3F
Reserved	[15]	Reserved	0
TACLS	[14:12]	CLE & ALE duration setting value (0~7) Duration = HCLK × TACLS	001
Reserved	[11]	Reserved	0
TWRPH0	[10:8]	TWRPH0 duration setting value (0~7) Duration = HCLK × ( TWRPH0+1 )	110
X16 Device	[7]	0 = External flash memories are not X16 device 1 = External flash memory is X16 device (READ ONLY)	0
TWRPH1	[6:4]	TWRPH1 duration Setting Value (0~7) Duration = HCLK × ( TWRPH1+1 )	110
Hardware nCE	[3]	Hardware Flash_nCE control 0 = Do not supports Flash_nCE control (Manual set) 1 = Supports Flash_nCE control	1
Bus Width	[2]	NAND Flash Memory I/O bus width 0 = 8-bit bus (RnB0) 1 = 16-bit bus (RnB0 and RnB1)	H/W Set
Page Size	[1]	Auto load page size of NAND Flash Memory 0 = 256/1K half word,           1 = 512/2K Bytes,	H/W Set
Address Cycle	[0]	Address cycle of NAND flash memory 0 = 3/4 address cycle           1 = 4/5 address cycle	H/W Set

## CONTROL REGISTER

Register	Address	R/W	Description	Reset Value
NFCONT	0x40C00004	R/W	NAND flash control register	0x0384

NFCONT	Bit	Description	Initial State
LdStrAddr	[27:16]	The address of the steppingstone to read or write when auto loading or storing <b>Note:</b> The bit [17:16] are fixed to zero.	0x00
EnbIllegalAccINT	[15]	Illegal access interrupt control 0 = Disable interrupt                      1 = Enable interrupt	0
EnbLoadINT	[14]	In Auto load, Data load completion interrupt control 0 = Disable interrupt                      1 = Enable interrupt	0
EnbStoreINT	[13]	In Auto store, Data store completion interrupt control 0 = Disable interrupt                      1 = Enable interrupt	0
EnbRnBINT	[12]	RnB status input signal transition interrupt control 0 = Disable RnB interrupt                1 = Enable RnB interrupt	0
RnB_TransMode	[11]	RnB transition detection configuration 0 = Detect low to high                    1 = Detect high to low	0
SpareECCLock	[10]	Lock Spare area ECC generation 0 = Unlock                                    1 = Lock	1
MainECCLock	[9]	Lock Main data area ECC generation 0 = Unlock                                    1 = Lock	1
InitECC	[8]	Initialize ECC decoder/encoder(Write-only) 0 = 1 = Initialize ECC decoder/encoder	0
Reg_nCE	[7]	NAND Flash Memory Flash_nCE control 0 = NAND flash chip enable(Active low) 1 = NAND flash chip disable (After AUTO Load / Store, nCE will be inactive) <b>Note:</b> It is controlled automatically in Auto Load / Store mode. You must control this value in Software mode. But if HW_nCE is set to 1, also controlled by H/W.	1
LoadPageSize	[6:4]	Auto load page size configuration (0 ~ 7) Size = Setting value + 1	000
Lock-tight	[3]	Lock-tight configuration 0 = Disable                                    1 = Enable <b>Note:</b> Once you set this bit to 1, you can't clear this. In this state, you can only read.	0
Lock	[2]	Lock configuration 0 = Disable                                    1 = Enable	1
Mode	[1:0]	NAND Flash controller operating mode selection 00 = Disable all mode                    01 = Auto load mode 10 = Auto store mode                    11 = Software Mode	00

**COMMAND REGISTER**

Register	Address	R/W	Description	Reset Value
NFCMMD	0x40C00008	R/W	NAND flash command set register	0x00

NFCMMD	Bit	Description	Initial State
NFCMMD1	[15:8]	NAND flash memory 2 <sup>nd</sup> command value	–
NFCMMD0	[7:0]	NAND flash memory command value	0x00

**NOTE:** When you use Advance Flash memory, it has 2<sup>nd</sup> cycle read command (h30). So If you want to do auto load you have to set the value at the REG\_CMMMD1.

**ADDRESS REGISTER**

Register	Address	R/W	Description	Reset Value
NFADDR	0x40C0000C	R/W	NAND flash address set register	0x0000XX00

NFADDR	Bit	Description	Initial State
NFADDR3	[31:24]	NAND flash memory address value3 (This value is only used at 4 <sup>th</sup> or 5 <sup>th</sup> address cycle)	0x00
NFADDR 2	[23:16]	NAND flash memory address value2	0x00
NFADDR 1	[15:8]	NAND flash memory address value1	0xXX
NFADDR 0	[7:0]	NAND flash memory address value0 In Software mode, only this value is used for Flash_IO	0x00

**NOTE:** Advance Flash's 1<sup>st</sup> and 2<sup>nd</sup> address is always column address. It means you don't need to care about 1<sup>st</sup> and 2<sup>nd</sup> address. So, When you want to do auto load or store, you can set the address from REG\_ADDR1 to REG\_ADDR2 for 4 cycle address memory and from REG\_ADDR1 to REG\_ADDR3 for 5 cycle address memory.

**DATA REGISTER**

Register	Address	R/W	Description	Reset Value
NFDATA	0x40C00010	R/W	NAND Flash data register	0xXXXX

NF_DATA	Bit	Description	Initial State
NFDATA1	[15:8]	NAND Flash read/program data value for I/O[15:8]	0xXX
NFDATA0	[7:0]	NAND Flash read/program data value for I/O[7:0] In case of write: Programming data In case of read: Reading data. These values are only used in Software mode.	0xXX



## MAIN DATA AREA ECC0 REGISTER

Register	Address	R/W	Description	Reset Value
NFMECCDATA0	0x40C00014	R/W	NAND Flash ECC register for main data read	0x00000000

NFMECCDATA0	Bit	Description	Initial State
ECCData0_1	[15:8]	1 <sup>st</sup> ECC for I/O[15:8]	0x00
ECCData0_0	[7:0]	1 <sup>st</sup> ECC for I/O[ 7:0] <b>Note:</b> In Software mode, Read this register when you need to read 1 <sup>st</sup> ECC value from NAND flash memory	0x00

## MAIN DATA AREA ECC1 REGISTER

Register	Address	R/W	Description	Reset Value
NFMECCDATA1	0x40C00018	R/W	NAND Flash ECC register for main data read	0x00000000

NFMECCDATA1	Bit	Description	Initial State
ECCData1_1	[15:8]	2 <sup>nd</sup> ECC for I/O[15:8]	0x00
ECCData1_0	[7:0]	2 <sup>nd</sup> ECC for I/O[ 7:0] <b>Note:</b> In Software mode, Read this register when you need to read 2 <sup>nd</sup> ECC value from NAND flash memory	0x00

## MAIN DATA AREA ECC2 REGISTER

Register	Address	R/W	Description	Reset Value
NFMECCDATA2	0x40C0001C	R/W	NAND Flash ECC register for main data read	0x00000000

NFMECCDATA2	Bit	Description	Initial State
ECCData2_1	[15:8]	3 <sup>rd</sup> ECC for I/O[15:8]	0x00
ECCData2_0	[7:0]	3 <sup>rd</sup> ECC for I/O[ 7:0] <b>Note:</b> In Software mode, Read this register when you need to read 3 <sup>rd</sup> ECC value from NAND flash memory	0x00

**MAIN DATA AREA ECC3 REGISTER**

Register	Address	R/W	Description	Reset Value
NFMECCDATA3	0x40C00020	R/W	NAND Flash ECC register for main data read (Advance Flash memory have 4byte ECC code )	0x00000000

NFMECCDATA3	Bit	Description	Initial State
ECCData3_1	[15:8]	4 <sup>th</sup> ECC for I/O[15:8]	0x00
ECCData3_0	[7:0]	4 <sup>th</sup> ECC for I/O[ 7:0] <b>Note:</b> In Software mode, Read this register when you need to read 4 <sup>th</sup> ECC value from NAND flash memory	0x00

**SPARE AREA ECC0 REGISTER**

Register	Address	R/W	Description	Reset Value
NFSECCDATA0	0x40C00024	R/W	NAND Flash ECC register for spare area data read	0x00000000

NFSECCDATA0	Bit	Description	Initial State
SPARE ECCData0_1	[15:8]	1 <sup>st</sup> ECC for I/O[15:8]	0x00
SPARE ECCData0_0	[7:0]	1 <sup>st</sup> ECC for I/O[ 7:0] <b>Note:</b> In Software mode, Read this register when you need to read 1 <sup>st</sup> ECC value from NAND flash memory	0x00

**SPARE AREA ECC1 REGISTER**

Register	Address	R/W	Description	Reset Value
NFSECCDATA1	0x40000028	R/W	NAND Flash ECC register for spare area data read	0x00000000

NFSECCDATA1	Bit	Description	Initial State
SPARE ECCData1_1	[15:8]	2 <sup>nd</sup> ECC for I/O[15:8]	0x00
SPARE ECCData1_0	[7:0]	2 <sup>nd</sup> ECC for I/O[ 7:0] <b>Note:</b> In Software mode, Read this register when you need to read 2 <sup>nd</sup> ECC value from NAND flash memory	0x00



## CONTROL STATUS REGISTER

Register	Address	R/W	Description	Reset Value
NFSTAT	0x40C0002C	R/W	NAND Flash operation status register	0xXX00

NFSTAT	Bit	Description	Initial State
IllegalAccess	[16]	Once Lock or Lock-tight is enabled, The illegal access (program, erase ...) to the memory makes this bit set. To clear this value write '1' 0 = Illegal access is not detected 1 = Illegal access is detected	0
AutoLoadDone	[15]	When Auto load operation is completed, this value set and issue interrupt if enabled. To clear this value write '1' 0 = Auto load completion is not detected 1 = Auto load completion is detected	0
AutoStoreDone	[14]	When Auto store operation is completed, this value set and issue interrupt if enabled. To clear this value write '1' 0 = Auto store completion is not detected 1 = Auto store completion is detected	0
RnB_TransDetect	[13]	When RnB transition is occurred, this value set and issue interrupt if enabled. To clear this value write '1' 0 = RnB transition is not detected 1 = RnB transition is detected	0
Flash_nCE	[12]	The status of Flash_nCE output pin (Read-only)	1
Flash_RnB1	[11]	The status of Flash_RnB1 input pin (Read-only) 0 = NAND Flash memory busy 1 = NAND Flash memory ready to operate	X
Flash_RnB0	[10]	The status of Flash_RnB0 input pin (Read-only) 0 = NAND Flash memory busy 1 = NAND Flash memory ready to operate	X
STON_A2	[9:0]	SteppingStone access address (Read-only)  This address indicates which part of the memory is accessed by the NAND Flash controller and is valid in auto load / store mode	0x00

**ECC0 STATUS REGISTER**

Register	Address	R/W	Description	Reset Value
NFESTAT0	0x40C00030	R/W	NAND Flash ECC Status register for I/O [7:0]	0x00000000

NFESTAT0	Bit	Description	Initial State
SErrorDataNo	[24:21]	In spare area, Indicates which number data is error	00
SErrorBitNo	[20:18]	In spare area, Indicates which bit is error	000
MErrorDataNo	[17:7]	In main data area, Indicates which number data is error	0x00
MErrorBitNo	[6:4]	In main data area, Indicates which bit is error	000
SpareError	[3:2]	Indicates whether spare area bit fail error occurred 00 = No Error            01 = 1-bit error(correctable) 10 = Multiple error    11 = ECC area error	00
MainError	[1:0]	Indicates whether main data area bit fail error occurred 00 = No Error            01 = 1-bit error(correctable) 10 = Multiple error    11 = ECC area error	00

**NOTE:** The above values are only valid when both NFMECCDATAN (NFSECCDATAN) and NFMECCN (NFSECC) have valid value.

**ECC1 STATUS REGISTER**

Register	Address	R/W	Description	Reset Value
NFESTAT1	0x40C00034	R/W	NAND Flash ECC Status register for I/O [15:8]	0x00000000

NFESTAT1	Bit	Description	Initial State
SErrorDataNo	[24:21]	In spare area, Indicates which number data is error	00
SErrorBitNo	[20:18]	In spare area, Indicates which bit is error	000
MErrorDataNo	[17:7]	In main data area, Indicates which number data is error	0x00
MErrorBitNo	[6:4]	In main data area, Indicates which bit is error	000
SpareError	[3:2]	Indicates whether spare area bit fail error occurred 00 = No Error            01 = 1-bit error(correctable) 10 = Multiple error    11 = ECC area error	00
MainError	[1:0]	Indicates whether main data area bit fail error occurred 00 = No Error            01 = 1-bit error(correctable) 10 = Multiple error    11 = ECC area error	00

**NOTE:** The above values are only valid when both NFMECCDATAN(NFSECCDATAN) and NFMECCN(NFSECC) have valid value.



**MAIN DATA AREA ECC0 STATUS REGISTER**

Register	Address	R/W	Description	Reset Value
NFMECC0	0x40C00038	R	NAND Flash ECC register for I/O [7:0]	0xFFFFFFFF

NFMECC0	Bit	Description	Initial State
MECC0_3	[31:24]	ECC: Error Correction Code #3	0xFF
MECC0_2	[23:16]	ECC: Error Correction Code #2	0xFF
MECC0_1	[15:8]	ECC: Error Correction Code #1	0xFF
MECC0_0	[7:0]	ECC: Error Correction Code #0	0xFF

**MAIN DATA AREA ECC1 STATUS REGISTER**

Register	Address	R/W	Description	Reset Value
NFMECC1	0x40C0003C	R	NAND Flash ECC register for data[15:8]	0xFFFFFFFF

NFMECC1	Bit	Description	Initial State
MECC1_3	[31:24]	ECC: Error Correction Code #3	0xFF
MECC1_2	[23:16]	ECC: Error Correction Code #2	0xFF
MECC1_1	[15:8]	ECC: Error Correction Code #1	0xFF
MECC1_0	[7:0]	ECC: Error Correction Code #0	0xFF

**SPARE AREA ECC STATUS REGISTER**

Register	Address	R/W	Description	Reset Value
NFSECC	0x40C00040	R	NAND Flash ECC register for I/O [15:0]	0xFFFFFFFF

NFSECC	Bit	Description	Initial State
SECC1_1	[31:24]	Spare area ECC1 Status for I/O[15:8]	0xFF
SECC1_0	[23:16]	Spare area ECC0 Status for I/O[15:8]	0xFF
SECC0_1	[15:8]	Spare area ECC1 Status for I/O[7:0]	0xFF
SECC0_0	[7:0]	Spare area ECC0 Status for I/O[7:0]	0xFF



**START BLOCK ADDRESS REGISTER**

Register	Address	R/W	Description	Reset Value
NFSBLK	0x40C00044	R/W	NAND Flash programmable start block address	0x000000

NFSBLK	Bit	Description	Initial State
SBLK_ADDR2	[23:16]	The 3 <sup>rd</sup> block address of the block erase operation	0x00
SBLK_ADDR1	[15:8]	The 2 <sup>nd</sup> block address of the block erase operation	0x00
SBLK_ADDR0	[7:0]	The 1 <sup>st</sup> block address of the block erase operation (Only bit [7:5] are valid when External Memory is old version and Only bit [7:6] are valid when External Memory is new version)	0x00

**NOTE:** Advance Flash's block Address starts from 3 address cycle. So Block address register only need 3Byte'

**END BLOCK ADDRESS REGISTER**

Register	Address	R/W	Description	Reset Value
NFEBLK	0x40C00048	R/W	NAND Flash programmable end block address	0x000000

NFEBLK	Bit	Description	Initial State
EBLK_ADDR2	[23:16]	The 3 <sup>rd</sup> block address of the block erase operation	0x00
EBLK_ADDR1	[15:8]	The 2 <sup>nd</sup> block address of the block erase operation	0x00
EBLK_ADDR0	[7:0]	The 1 <sup>st</sup> block address of the block erase operation (Only bit [7:5] are valid when External Memory is old version and Only bit [7:6] are valid when External Memory is new version)	0x00

**NOTE:** Advance Flash's block Address starts from 3 address cycle. So Block address register only need 3Byte'

## NOTES

# 5 BUS MATRIX

## OVERVIEW

S3C24A0A MATRIX provides the interface between dual AHB bus and Memory sub-system. It is used for achieving high system performance by accessing various kinds of memory (SDRAM, SRAM, Flash Memory, ROM etc) from different AHB bus (one is for system and the other is for image) at the same time. S3C24A0A have two MATRIX cores because it has two memory ports, and each MATRIX can select the priority between rotation type and fixed type. User can select which one is excellent for improving system performance.

Figure 5-1 shows the configuration of MATRIX and Memory sub-system of S3C24A0A. It also shows the model of external memory. Both AHB bus can access all MATRIX core and MATRIX core is dedicated each memory port respectively. So it can operate separately at the same time. It's a key of MATRIX.

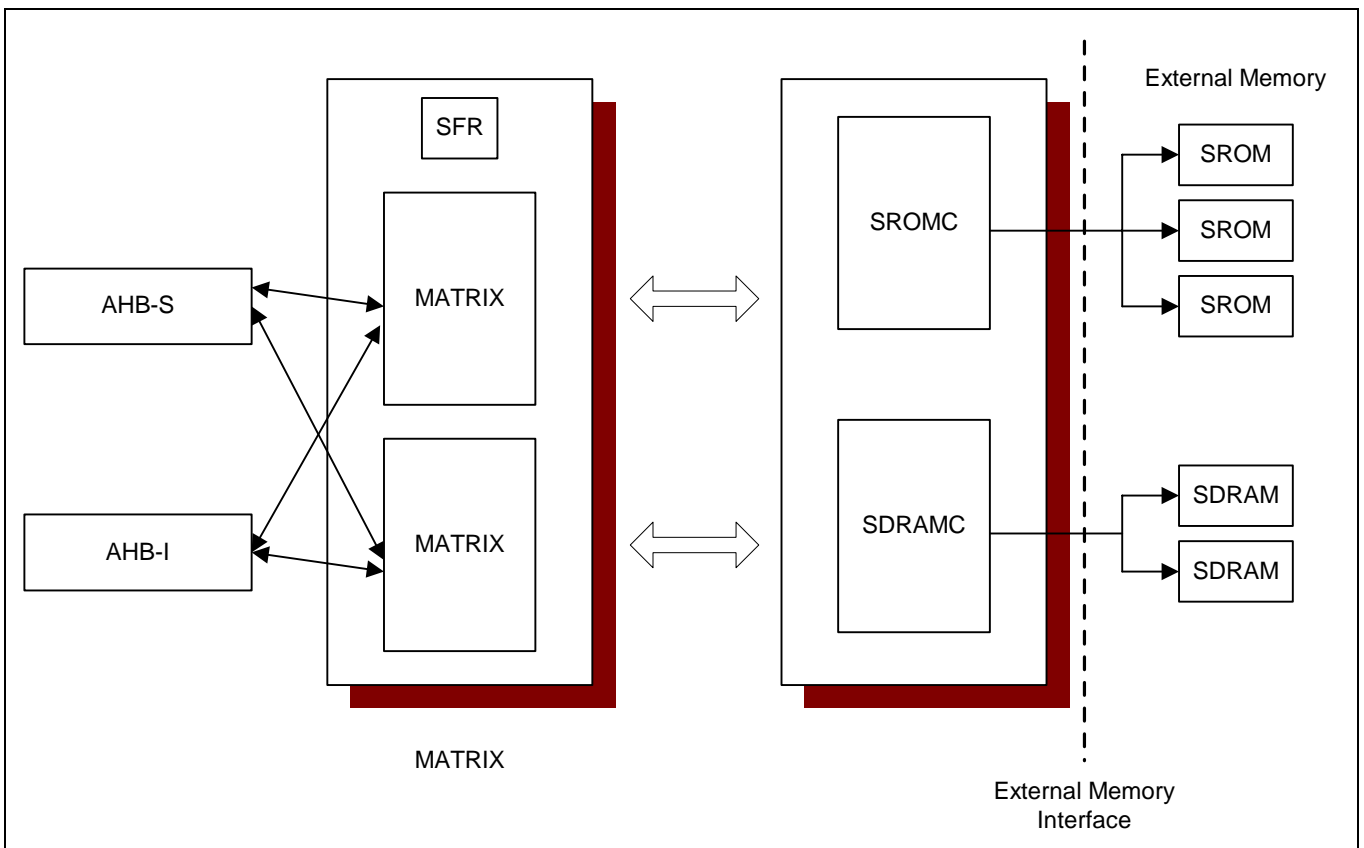

Figure 5-1. Configuration of MATRIX and Memory Sub-System

## BUS PRIORITY MAP

The bus arbitration logic determines the priorities of bus masters. It supports a combination of rotation priority mode and fixed priority mode.

Priority Order in AHB_S	AHB_S Components	AHB_I Components	Priority Order in AHB_I
0 (Rotation Priority)	DMA 0	Display Controller	0
	DMA 1	Camera-Codec Path	1
	DMA 2	Camera-Preview Path	2
	DMA 3	MPEG-4 ME	3
1	USB Host	MPEG-4 MC	4 (Rotation Priority)
2	ARM926EJ D-cache	MPEG-4 DCT/Q	
3	ARM926EJ I-cache	MPEG-4 VLX	
		Video Post-processor	
		AHB_S Master (AHB_I access of ARM926EJ)	5

**SPECIAL FUNCTION REGISTERS****SROMC/NFLASHC ARBITER PRIORITY REGISTER (PRIORITY 0)**

Register	Address	R/W	Description	Reset Value
PRIORITY0	0X40CE0000	R/W	Priority control register	0x0000_0000

PRIORITY0	Bit	Description	Initial State
FIX_PRI_TYP	[1]	Priority type 0 = Provide higher priority to S-Bus when user set fixed priority 1 = Provide higher priority to I-Bus when user set fixed priority	0
PRI_TYP	[0]	Priority type 0 = Fixed priority                      1 = Rotating priority	0

**SDRAMC ARBITER PRIORITY REGISTER (PRIORITY 1)**

Register	Address	R/W	Description	Reset Value
PRIORITY1	0X40CE0004	R/W	Priority control register	0x0000_0000

PRIORITY1	Bit	Description	Initial State
FIX_PRI_TYP	[1]	Priority type 0 = Provide higher priority to S-Bus when user set fixed priority 1 = Provide higher priority to I-Bus when user set fixed priority	0
PRI_TYP	[0]	Priority type 0 = Fixed priority                      1 = Rotating priority	0

# 6

## INTERRUPT CONTROLLER

### OVERVIEW

The interrupt controller in S3C24A0A receives the requests for interrupt services from 61 interrupt sources. These interrupt sources are provided by internal peripherals such as a DMA controller, UART and IIC, etc. Among these interrupt sources; the UART0 and UART1 error interrupts are 'OR'ed to the interrupt controller. And, two interrupts from a Display/Post processor, two interrupts from Timer3/Timer4, and four interrupts from DMA controller are individually 'OR'ed to the interrupt controller. Also, the IrDA/Memory stick interrupts, two interrupts from ADC/PENUP/PENDN are individually 'OR'ed to the interrupt controller.

The role of the interrupt controller is to ask for the FIQ or IRQ interrupt requests to the ARM926EJ core after the arbitration process when there are multiple interrupt requests from internal peripherals and external interrupt request pins.

The arbitration process is performed by the hardware priority logic and the result is written to the interrupt pending register and user's notice that registers to know which interrupt has been requested.

## FUNCTIONAL DESCRIPTION

### F-BIT AND I-BIT OF PSR (PROGRAM STATUS REGISTER)

If the F-bit of PSR (program status register in ARM926EJ CPU) is set to 1, the CPU does not accept the FIQ (fast interrupt request) from the interrupt controller. If I-bit of PSR (program status register in ARM926EJ CPU) is set to 1, the CPU does not accept the IRQ (interrupt request) from the interrupt controller. So, to enable the interrupt reception, the F-bit or I-bit of PSR has to be cleared to 0 and also the corresponding bit of INTMSK has to be set to 0.

### INTERRUPT MODE

ARM926EJ has 2 types of interrupt mode, FIQ or IRQ. All the interrupt sources determine the mode of interrupt to be used at interrupt request.

### INTERRUPT PENDING REGISTER

S3C24A0A has two interrupt pending registers. The one is source pending register (SRCPND), the other is interrupt pending register (INTPND). These pending registers indicate whether an interrupt request is pending or not. When the interrupt sources request interrupt service the corresponding bits of SRCPND register are set to 1, at the same time the only one bit of INTPND register is set to 1 automatically after arbitration process. If interrupts are masked, the corresponding bits of SRCPND register are set to 1, but the bit of INTPND register is not changed. Once the pending bit of INTPND register is set, then the interrupt service routine starts whenever the I-flag or F-flag is cleared to 0. The SRCPND and INTPND registers can be read and written, so the service routine must clear the pending condition by writing a 1 to the corresponding bit in SRCPND register first and then clear the pending condition in INTPND registers same method.

### INTERRUPT MASK REGISTER

This indicates that an interrupt has been disabled if the corresponding mask bit is 1. If an interrupt mask bit of INTMSK is 0, the interrupt will be serviced normally. If the corresponding mask bit is 1 and the interrupt is generated, the source pending bit will be set.

## INTERRUPT SOURCES

Interrupt controller supports 61 interrupt sources as shown in below table.

Among the 32 interrupt sources, each interrupt source corresponding to INT\_ADC, INT\_PCM\_MSTICK, INT\_AC97\_NFLASH, INT\_DMA\_PBUS, INT\_DMA\_GBUS, INT\_DMA\_MBUS, INT\_UART0, INT\_UART1, and INT\_CAMPRO is an 'OR'ed interrupt which combines multiple sub-interrupt sources connected to the corresponding interrupt sources, and provides a single interrupt source to interrupt controller.

Sources	Descriptions	Arbiter Group
INT_ADC_PENUP_DOWN	ADC EOC/Pen up/Pen down interrupt	ARB5
INT_RTC	RTC alarm interrupt	ARB5
INT_VLX_SPI1	SPI1 interrupt	ARB5
INT_IrDA_MSTICK	IrDA/MSTICK interrupt	ARB5
INT_IIC	IIC interrupt	ARB4
INT_USBH	USB host interrupt	ARB4
INT_USBD	USB device interrupt	ARB4
INT_AC97_NFLASH	AC97/NFLASH interrupt	ARB4
INT_UART1	UART1 interrupt ( ERR, RXD, TXD)	ARB4
INT_SPI0	SPI0 interrupt	ARB4
INT_SDI	SDI interrupt	ARB3
INT_DMA	DMA channels for S-bus interrupt	ARB3
INT_MODEM	MODEM interface interrupt	ARB3
INT_CAMIF_PREVIEW	Camera interface interrupt	ARB3
INT_UART0	UART0 interrupt ( ERR, RXD, TXD)	ARB3
INT_WDT_BATFLT	WDT/BATFLT interrupt	ARB3
INT_CAMIF_CODEC	Camera interface interrupt	ARB2
INT_LCD_POST	LCD/POST interrupt	ARB2
INT_TIMER3, 4	Timer3/4 interrupt	ARB2
INT_TIMER2	Timer2 interrupt	ARB2
INT_TIMER1	Timer1 interrupt	ARB2
INT_TIMER0	Timer0 interrupt	ARB2
INT_KEYPAD	Keypad interrupt	ARB1
INT_ME	ME interrupt	ARB1
INT_MC	MC interrupt	ARB1
INT_DCTQ	DCTQ interrupt	ARB1
INT_TIC	RTC Time tick interrupt	ARB1
EINT15_18	External interrupt 15-18	ARB1
EINT11_14	External interrupt 11-14	ARB0
EINT7_10	External interrupt 7-10	ARB0
EINT3_6	External interrupt 3-6	ARB0
EINT0_2	External interrupt 0-2	ARB0



**INTERRUPT PRIORITY GENERATING BLOCK**

The priority logic for 32 interrupt requests is composed of seven rotation based arbiters: six first-level arbiters and one second-level arbiter as shown in the following Figure.

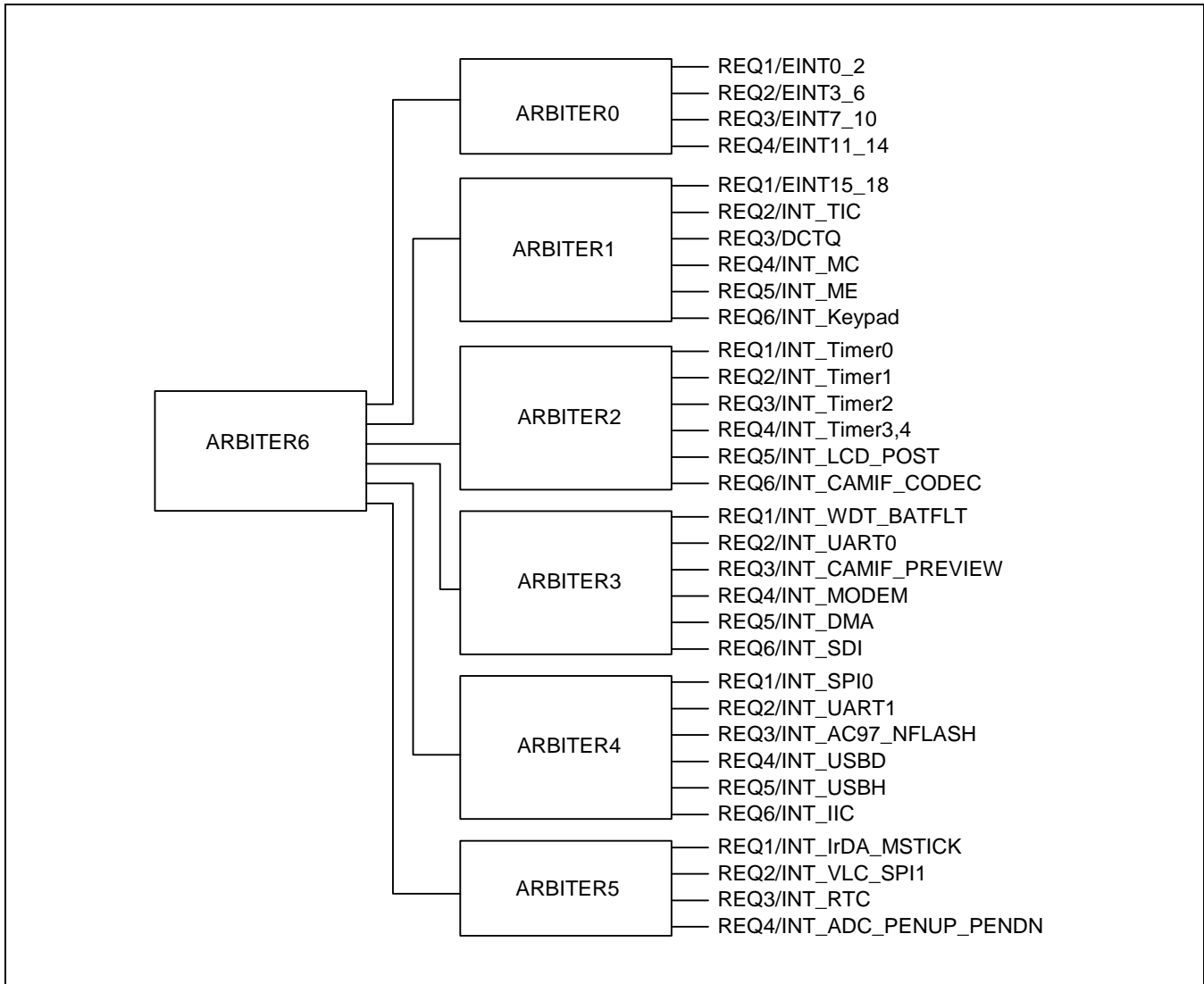

**Figure 6-1. Priority Generating Block**

### Interrupt Priority

Each arbiter can handle six interrupt requests based on the one bit arbiter mode control (ARB\_MODE) and two bits of selection control signals (ARB\_SEL) as follows:

- If ARB\_SEL bits are 00b, the priority order is REQ0, REQ1, REQ2, REQ3, REQ4, and REQ5.
- If ARB\_SEL bits are 01b, the priority order is REQ0, REQ2, REQ3, REQ4, REQ1, and REQ5.
- If ARB\_SEL bits are 10b, the priority order is REQ0, REQ3, REQ4, REQ1, REQ2, and REQ5.
- If ARB\_SEL bits are 11b, the priority order is REQ0, REQ4, REQ1, REQ2, REQ3, and REQ5.

Note that REQ0 of an arbiter is always the highest priority, and REQ5 is the lowest one. In addition, by changing the ARB\_SEL bits, we can rotate the priority of REQ1 - REQ4.

Here, if ARB\_MODE bit is set to 0, ARB\_SEL bits are not automatically changed, thus the arbiter operates in the fixed priority mode. (Note that even in this mode, we can change the priority by manually changing the ARB\_SEL bits.). On the other hand, if ARB\_MODE bit is 1, ARB\_SEL bits are changed in rotation fashion, e.g., if REQ1 is serviced, ARB\_SEL bits are changed to 01b automatically so as to make REQ1 the lowest priority one. The detailed rule of ARB\_SEL change is as follows.

- If REQ0 or REQ5 is serviced, ARB\_SEL bits are not changed at all.
- If REQ1 is serviced, ARB\_SEL bits are changed to 01b.
- If REQ2 is serviced, ARB\_SEL bits are changed to 10b.
- If REQ3 is serviced, ARB\_SEL bits are changed to 11b.
- If REQ4 is serviced, ARB\_SEL bits are changed to 00b.

### VECTORED INTERRUPT MODE (ONLY FOR IRQ)

S3C24A0A has a vectored interrupt mode, to reduce the interrupt latency time.

If ARM926EJ receives the IRQ interrupt request from the interrupt controller, it executes an instruction at

0x00000018. The LDR instruction which loads to PC the address written in Vector Address Register, one of special function registers in Interrupt controller, is located at 0x00000018. That is,

```
@0x0000_0018 : LDR PC, [VAR]
```

where, VAR is the special function register at 0x4020\_002c of interrupt controller.

The LDR instruction lets the program counter be the vector table address corresponding to each interrupt source. The user program code must locate the branch instruction, which branches to the corresponding ISR (interrupt service routine) at each vector table address.

For example, If TIMER1 is IRQ, the LDR instruction at 0x00000018 which lets PC be 0x0000004c, is executed . 0x0000004c is automatically written to Vector Address Register by hardware logic.



And the branch instruction, which jumps to the ISR, is located at 0x0000004c.

Vector Number	Vector Name	Interrupt Vector Address
0	EINT0_2	0x0000_0020
1	EINT3_6	0x0000_0024
2	EINT7_10	0x0000_0028
3	EINT11_14	0x0000_002c
4	EINT15_18	0x0000_0030
5	INT_TICK	0x0000_0034
6	INT_DCTQ	0x0000_0038
7	INT_MC	0x0000_003c
8	INT_ME	0x0000_0040
9	INT_KEYPAD	0x0000_0044
10	INT_TIMER0	0x0000_0048
11	INT_TIMER1	0x0000_004c
12	INT_TIMER2	0x0000_0050
13	INT_TIMER3,4	0x0000_0054
14	INT_LCD_POST	0x0000_0058
15	INT_CAMIF_CODEC	0x0000_005c
16	INT_WDT_BATFLT	0x0000_0060
17	INT_UART0	0x0000_0064
18	INT_CAMIF_PREVIEW	0x0000_0068
19	INT_MODEM	0x0000_006c
20	INT_DMA	0x0000_0070
21	INT_SDI	0x0000_0074
22	INT_SPI0	0x0000_0078
23	INT_UART1	0x0000_007c
24	INT_AC97_NFLASH	0x0000_0080
25	INT_USBD	0x0000_0084
26	INT_USBH	0x0000_0088
27	INT_IIC	0x0000_008c
28	INT_IrDA_MSTICK	0x0000_0090
29	INT_VLX_SPI1	0x0000_0094
30	INT_RTC	0x0000_0098
31	INT_ADC_PENUP_DOWN	0x0000_009c

## SPECIAL FUNCTION REGISTERS

There are five control registers in the interrupt controller: source pending register, interrupt mode register, mask register, priority register, and interrupt pending register.

All the interrupt requests from the interrupt sources are first registered in the source pending register. They are divided into two groups based on the interrupt mode register, i.e., one FIQ request and the remaining IRQ requests. Arbitration process is performed for the multiple IRQ requests based on the priority register.

### SOURCE PENDING REGISTER (SRCPND)

SRCPND register is composed of 32 bits each of which is related to an interrupt source. Each bit is set to 1 if the corresponding interrupt source generates the interrupt request and waits for the interrupt to be serviced. By reading this register, we can see the interrupt sources waiting for their requests to be serviced. Note that each bit of SRCPND register is automatically set by the interrupt sources regardless of the masking bits in the INTMASK register. In addition, it is not affected by the priority logic of interrupt controller.

In the interrupt service routine for a specific interrupt source, the corresponding bit of SRCPND register has to be cleared to get the interrupt request from the same source correctly. If you return from the ISR without clearing the bit, interrupt controller operates as if another interrupt request comes in from the same source. In other words, if a specific bit of SRCPND register is set to 1, it is always considered as a valid interrupt request waiting to be serviced.

The specific time to clear the corresponding bit depends on the user's requirement. The bottom line is that if you want to receive another valid request from the same source you should clear the corresponding bit first, and then enable the interrupt.

You can clear a specific bit of SRCPND register by writing a data to this register. It clears only the bit positions of SRCPND corresponding to those set to one in the data. The bit positions corresponding to those that are set to 0 in the data remains as they are with no change.

Register	Address	R/W	Description	Reset Value
SRCPND	0X40200000	R/W	Indicates the interrupt request status. 0 = The interrupt has not been requested 1 = The interrupt source has asserted the interrupt request	0x00000000

**NOTE:** When the user clear a interrupt pending, specific bit of SRCPND and INTPND, has to clear the bit of SRCPND

SRCPND	Bit	Description	Initial State
INT_ADC_PENUP_DOWN	[31]	0 = Not requested, 1 = Requested (SUBSRCPND)	0
INT_RTC	[30]	0 = Not requested, 1 = Requested	0
INT_VLX_SPI1	[29]	0 = Not requested, 1 = Requested (SUBSRCPND)	0
INT_IrDA_MSTICK	[28]	0 = Not requested, 1 = Requested (SUBSRCPND)	0
INT_IIC	[27]	0 = Not requested, 1 = Requested	0
INT_USBH	[26]	0 = Not requested, 1 = Requested	0
INT_USBD	[25]	0 = Not requested, 1 = Requested	0
INT_AC97_NFLASH	[24]	0 = Not requested, 1 = Requested (SUBSRCPND)	0
INT_UART1	[23]	0 = Not requested, 1 = Requested (SUBSRCPND)	0
INT_SPI0	[22]	0 = Not requested, 1 = Requested	0
INT_SDI	[21]	0 = Not requested, 1 = Requested	0
INT_DMA	[20]	0 = Not requested, 1 = Requested (SUBSRCPND)	0
INT_MODEM	[19]	0 = Not requested, 1 = Requested	0
INT_CAMIF_PREVIEW	[18]	0 = Not requested, 1 = Requested	0
INT_UART0	[17]	0 = Not requested, 1 = Requested (SUBSRCPND)	0
INT_WDT_BATFLT	[16]	0 = Not requested, 1 = Requested (SUBSRCPND)	0
INT_CAMIF_CODEC	[15]	0 = Not requested, 1 = Requested	0
INT_LCD_POST	[14]	0 = Not requested, 1 = Requested (SUBSRCPND)	0
INT_TIMER3, 4	[13]	0 = Not requested, 1 = Requested (SUBSRCPND)	0
INT_TIMER2	[12]	0 = Not requested, 1 = Requested	0
INT_TIMER1	[11]	0 = Not requested, 1 = Requested	0
INT_TIMER0	[10]	0 = Not requested, 1 = Requested	0
INT_KEYPAD	[9]	0 = Not requested, 1 = Requested	0
INT_ME	[8]	0 = Not requested, 1 = Requested	0
INT_MC	[7]	0 = Not requested, 1 = Requested	0
INT_DCTQ	[6]	0 = Not requested, 1 = Requested	0
INT_TIC	[5]	0 = Not requested, 1 = Requested	0
EINT15_18	[4]	0 = Not requested, 1 = Requested	0
EINT11_14	[3]	0 = Not requested, 1 = Requested	0
EINT7_10	[2]	0 = Not requested, 1 = Requested	0
EINT3_6	[1]	0 = Not requested, 1 = Requested	0
EINT0_2	[0]	0 = Not requested, 1 = Requested	0

**INTERRUPT MODE REGISTER (INTMOD)**

This register is composed of 32 bits each of which is related to an interrupt source. If a specific bit is set to 1, the corresponding interrupt is processed in the FIQ (fast interrupt) mode. Otherwise, it is processed in the IRQ mode (normal interrupt).

Note that at most only one interrupt source can be serviced in the FIQ mode in the interrupt controller. (You should use the FIQ mode only for the urgent interrupt.) Thus, only one bit of INTMOD can be set to 1 at most.

This register is write-only one, thus it cannot be read out.

Register	Address	R/W	Description	Reset Value
INTMOD	0X40200004	R/W	Interrupt mode register. 0 = IRQ mode      1 = FIQ mode	0x00000000

**NOTE:** If an interrupt mode is set to FIQ mode in INTMOD register, FIQ interrupt will not affect INTPND and INTOFFSET registers. The INTPND and INTOFFSET registers are valid only for IRQ mode interrupt source.

INTMOD	Bit	Description	Initial State
INT_ADC_PENUP_DOWN	[31]	0 = IRQ, 1 = FIQ	0
INT_RTC	[30]	0 = IRQ, 1 = FIQ	0
INT_VLX_SPI1	[29]	0 = IRQ, 1 = FIQ	0
INT_IrDA_MSTICK	[28]	0 = IRQ, 1 = FIQ	0
INT_IIC	[27]	0 = IRQ, 1 = FIQ	0
INT_USBH	[26]	0 = IRQ, 1 = FIQ	0
INT_USBD	[25]	0 = IRQ, 1 = FIQ	0
INT_AC97_NFLASH	[24]	0 = IRQ, 1 = FIQ	0
INT_UART1	[23]	0 = IRQ, 1 = FIQ	0
INT_SPI0	[22]	0 = IRQ, 1 = FIQ	0
INT_SDI	[21]	0 = IRQ, 1 = FIQ	0
INT_DMA	[20]	0 = IRQ, 1 = FIQ	0
INT_MODEM	[19]	0 = IRQ, 1 = FIQ	0
INT_CAMIF_PREVIEW	[18]	0 = IRQ, 1 = FIQ	0
INT_UART0	[17]	0 = IRQ, 1 = FIQ	0
INT_WDT_BATFLT	[16]	0 = IRQ, 1 = FIQ	0
INT_CAMIF_CODEC	[15]	0 = IRQ, 1 = FIQ	0
INT_LCD_POST	[14]	0 = IRQ, 1 = FIQ	0
INT_TIMER3,4	[13]	0 = IRQ, 1 = FIQ	0
INT_TIMER2	[12]	0 = IRQ, 1 = FIQ	0
INT_TIMER1	[11]	0 = IRQ, 1 = FIQ	0
INT_TIMER0	[10]	0 = IRQ, 1 = FIQ	0
INT_KEYPAD	[9]	0 = IRQ, 1 = FIQ	0
INT_ME	[8]	0 = IRQ, 1 = FIQ	0
INT_MC	[7]	0 = IRQ, 1 = FIQ	0
INT_DCTQ	[6]	0 = IRQ, 1 = FIQ	0
INT_TIC	[5]	0 = IRQ, 1 = FIQ	0
EINT15_18	[4]	0 = IRQ, 1 = FIQ	0
EINT11_14	[3]	0 = IRQ, 1 = FIQ	0
EINT7_10	[2]	0 = IRQ, 1 = FIQ	0
EINT3_6	[1]	0 = IRQ, 1 = FIQ	0
EINT0_2	[0]	0 = IRQ, 1 = FIQ	0

**INTERRUPT MASK REGISTER (INTMSK)**

Each of the 32 bits in the interrupt mask register is related to an interrupt source. If you set a specific bit to 1, the interrupt request from the corresponding interrupt source is not serviced by the CPU. (Note that even in such a case, the corresponding bit of SRCPND register is set to 1). If the mask bit is 0, the interrupt request can be serviced.

Register	Address	R/W	Description	Reset Value
INTMSK	0X40200008	R/W	Determines which interrupt source is masked. The masked interrupt source will not be serviced. 0 = Interrupt service is available 1 = Interrupt service is masked	0xffffffff



INTMSK	Bit	Description	Initial State
INT_ADC_PENUP_DOWN	[31]	0 = Service available, 1 = Masked	1
INT_RTC	[30]	0 = Service available, 1 = Masked	1
INT_VLX_SPI1	[29]	0 = Service available, 1 = Masked	1
INT_IrDA_MSTICK	[28]	0 = Service available, 1 = Masked	1
INT_IIC	[27]	0 = Service available, 1 = Masked	1
INT_USBH	[26]	0 = Service available, 1 = Masked	1
INT_USBD	[25]	0 = Service available, 1 = Masked	1
INT_AC97_NFLASH	[24]	0 = Service available, 1 = Masked	1
INT_UART1	[23]	0 = Service available, 1 = Masked	1
INT_SPI0	[22]	0 = Service available, 1 = Masked	1
INT_SDI	[21]	0 = Service available, 1 = Masked	1
INT_DMA	[20]	0 = Service available, 1 = Masked	1
INT_MODEM	[19]	0 = Service available, 1 = Masked	1
INT_CAMIF_PREVIEW	[18]	0 = Service available, 1 = Masked	1
INT_UART0	[17]	0 = Service available, 1 = Masked	1
INT_WDT_BATFLT	[16]	0 = Service available, 1 = Masked	1
INT_CAMIF_CODEC	[15]	0 = Service available, 1 = Masked	1
INT_LCD_POST	[14]	0 = Service available, 1 = Masked	1
INT_TIMER3, 4	[13]	0 = Service available, 1 = Masked	1
INT_TIMER2	[12]	0 = Service available, 1 = Masked	1
INT_TIMER1	[11]	0 = Service available, 1 = Masked	1
INT_TIMER0	[10]	0 = Service available, 1 = Masked	1
INT_KEYPAD	[9]	0 = Service available, 1 = Masked	1
INT_ME	[8]	0 = Service available, 1 = Masked	1
INT_MC	[7]	0 = Service available, 1 = Masked	1
INT_DCTQ	[6]	0 = Service available, 1 = Masked	1
INT_TIC	[5]	0 = Service available, 1 = Masked	1
EINT15_18	[4]	0 = Service available, 1 = Masked	1
EINT11_14	[3]	0 = Service available, 1 = Masked	1
EINT7_10	[2]	0 = Service available, 1 = Masked	1
EINT3_6	[1]	0 = Service available, 1 = Masked	1
EINT0_2	[0]	0 = Service available, 1 = Masked	1

## PRIORITY REGISTER (PRIORITY)

Register	Address	R/W	Description	Reset Value
PRIORITY	0X4020000C	R/W	IRQ priority control register	0x7f

PRIORITY	Bit	Description	Initial State
ARB_SEL6	[20:19]	Arbiter 6 group priority order set 00 = REQ 0-1-2-3-4-5      01 = REQ 0-2-3-4-1-5 10 = REQ 0-3-4-1-2-5      11 = REQ 0-4-1-2-3-5	0
ARB_SEL5	[18:17]	Arbiter 5 group priority order set 00 = REQ 1-2-3-4      01 = REQ 2-3-4-1 10 = REQ 3-4-1-2      11 = REQ 4-1-2-3	0
ARB_SEL4	[16:15]	Arbiter 4 group priority order set 00 = REQ 0-1-2-3-4-5      01 = REQ 0-2-3-4-1-5 10 = REQ 0-3-4-1-2-5      11 = REQ 0-4-1-2-3-5	0
ARB_SEL3	[14:13]	Arbiter 3 group priority order set 00 = REQ 0-1-2-3-4-5      01 = REQ 0-2-3-4-1-5 10 = REQ 0-3-4-1-2-5      11 = REQ 0-4-1-2-3-5	0
ARB_SEL2	[12:11]	Arbiter 2 group priority order set 00 = REQ 0-1-2-3-4-5      01 = REQ 0-2-3-4-1-5 10 = REQ 0-3-4-1-2-5      11 = REQ 0-4-1-2-3-5	0
ARB_SEL1	[10:9]	Arbiter 1 group priority order set 00 = REQ 0-1-2-3-4-5      01 = REQ 0-2-3-4-1-5 10 = REQ 0-3-4-1-2-5      11 = REQ 0-4-1-2-3-5	0
ARB_SEL0	[8:7]	Arbiter 0 group priority order set 00 = REQ 1-2-3-4      01 = REQ 2-3-4-1 10 = REQ 3-4-1-2      11 = REQ 4-1-2-3	0
ARB_MODE6	[6]	Arbiter 6 group priority rotate enable 0 = Priority does not rotate, 1 = Priority rotate enable	1
ARB_MODE5	[5]	Arbiter 5 group priority rotate enable 0 = Priority does not rotate, 1 = Priority rotate enable	1
ARB_MODE4	[4]	Arbiter 4 group priority rotate enable 0 = Priority does not rotate, 1 = Priority rotate enable	1
ARB_MODE3	[3]	Arbiter 3 group priority rotate enable 0 = Priority does not rotate, 1 = Priority rotate enable	1
ARB_MODE2	[2]	Arbiter 2 group priority rotate enable 0 = Priority does not rotate, 1 = Priority rotate enable	1
ARB_MODE1	[1]	Arbiter 1 group priority rotate enable 0 = Priority does not rotate, 1 = Priority rotate enable	1
ARB_MODE0	[0]	Arbiter 0 group priority rotate enable 0 = Priority does not rotate, 1 = Priority rotate enable	1

**INTERRUPT PENDING REGISTER (INTIPND)**

Each of the 32 bits in the interrupt pending register shows whether the corresponding interrupt request is the highest priority one that is unmasked and waits for the interrupt to be serviced. Since INTPND is located after the priority logic, only one bit can be set to 1 at most, and that is the very interrupt request generating IRQ to CPU. In interrupt service routine for IRQ, you can read this register to determine the interrupt source to be serviced among 32 sources.

Like the SRCPND, this register has to be cleared in the interrupt service routine after clearing SRCPND register. We can clear a specific bit of INTPND register by writing a data to this register. It clears only the bit positions of INTPND corresponding to those set to one in the data. The bit positions corresponding to those that are set to 0 in the data remains as they are with no change.

Register	Address	R/W	Description	Reset Value
INTPND	0X40200010	R/W	Indicates the interrupt request status. 0 = The interrupt has not been requested 1 = The interrupt source has asserted the interrupt request	0x00000000

**NOTE:** If the FIQ mode interrupt is occurred, the corresponding bit of INTPND will not be turned on. Because the INTPND register is available only for IRQ mode interrupt.

INTPND	Bit	Description	Initial State
INT_ADC_PENUP_DOWN	[31]	0 = Not requested, 1 = Requested	0
INT_RTC	[30]	0 = Not requested, 1 = Requested	0
INT_VLX_SPI1	[29]	0 = Not requested, 1 = Requested	0
INT_IrDA_MSTICK	[28]	0 = Not requested, 1 = Requested	0
INT_IIC	[27]	0 = Not requested, 1 = Requested	0
INT_USBH	[26]	0 = Not requested, 1 = Requested	0
INT_USBD	[25]	0 = Not requested, 1 = Requested	0
INT_AC97_NFLASH	[24]	0 = Not requested, 1 = Requested	0
INT_UART1	[23]	0 = Not requested, 1 = Requested	0
INT_SPI0	[22]	0 = Not requested, 1 = Requested	0
INT_SDI	[21]	0 = Not requested, 1 = Requested	0
INT_DMA	[20]	0 = Not requested, 1 = Requested	0
INT_MODEM	[19]	0 = Not requested, 1 = Requested	0
INT_CAMIF_PREVIEW	[18]	0 = Not requested, 1 = Requested	0
INT_UART0	[17]	0 = Not requested, 1 = Requested	0
INT_WDT_BATFLT	[16]	0 = Not requested, 1 = Requested	0
INT_CAMIF_CODEC	[15]	0 = Not requested, 1 = Requested	0
INT_LCD_POST	[14]	0 = Not requested, 1 = Requested	0
INT_TIMER3,4	[13]	0 = Not requested, 1 = Requested	0
INT_TIMER2	[12]	0 = Not requested, 1 = Requested	0
INT_TIMER1	[11]	0 = Not requested, 1 = Requested	0
INT_TIMER0	[10]	0 = Not requested, 1 = Requested	0
INT_KEYPAD	[9]	0 = Not requested, 1 = Requested	0
INT_ME	[8]	0 = Not requested, 1 = Requested	0
INT_MC	[7]	0 = Not requested, 1 = Requested	0
INT_DCTQ	[6]	0 = Not requested, 1 = Requested	0
INT_TIC	[5]	0 = Not requested, 1 = Requested	0
EINT15_18	[4]	0 = Not requested, 1 = Requested	0
EINT11_14	[3]	0 = Not requested, 1 = Requested	0
EINT7_10	[2]	0 = Not requested, 1 = Requested	0
EINT3_6	[1]	0 = Not requested, 1 = Requested	0
EINT0_2	[0]	0 = Not requested, 1 = Requested	0

**INTERRUPT OFFSET REGISTER (INTOFFSET)**

The number in the interrupt offset register shows which interrupt request of IRQ mode is in the INTPND register. This bit can be cleared automatically by clearing SRCPND and INTPND.

Register	Address	R/W	Description	Reset Value
INTOFFSET	0X40200014	R	Indicates the IRQ interrupt request source	0x00000000

INT Source	The OFFSET Value	INT Source	The OFFSET Value
INT_ADC_PENUP_DOWN	31	INT_CAMIF_CODEC	15
INT_RTC	30	INT_LCD_POST	14
INT_VLX_SPI1	29	INT_TIMER3,4	13
INT_IrDA_MSTICK	28	INT_TIMER2	12
INT_IIC	27	INT_TIMER1	11
INT_USBH	26	INT_TIMER0	10
INT_USBD	25	INT_KEYPAD	9
INT_AC97_NFLASH	24	INT_ME	8
INT_UART1	23	INT_MC	7
INT_SPI0	22	INT_DCTQ	6
INT_SDI	21	INT_TIC	5
INT_DMA	20	EINT15_18	4
INT_MODEM	19	EINT11_14	3
INT_CAMIF_PREVIEW	18	EINT7_10	2
INT_UART0	17	EINT3_6	1
INT_WDT_BATFLT	16	EINT0_2	0

**NOTE:** If the FIQ mode interrupt is occurred, the INTOFFSET will not be affected. Because the INTOFFSET register is available only for IRQ mode interrupt.

**SUB SOURCE PENDING REGISTER (SUBSRCPND)**

You can clear a specific bit of SUBSRCPND register by writing a data to this register. It clears only the bit positions of the SUBSRCPND corresponding to those set to one in the data. The bit positions corresponding to those that are set to 0 in the data remains as they are with no change.

Register	Address	R/W	Description	Reset Value
SUBSRCPND	0X402000018	R/W	Indicates the interrupt request status. 0 = The interrupt has not been requested 1 = The interrupt source has asserted the interrupt request	0x00000000

SUBSRCPND	Bit	Description	Initial State
Reserved	[31:29]	–	–
INT_DMA3	[28]	0 = Not requested, 1 = Requested	0
INT_DMA2	[27]	0 = Not requested, 1 = Requested	0
INT_DMA1	[26]	0 = Not requested, 1 = Requested	0
INT_DMA0	[25]	0 = Not requested, 1 = Requested	0
INT_VLX	[24]	0 = Not requested, 1 = Requested	0
INT_SPI1	[23]	0 = Not requested, 1 = Requested	0
INT_AC97	[22]	0 = Not requested, 1 = Requested	0
INT_NFLASH	[21]	0 = Not requested, 1 = Requested	0
INT_DISP_FRAME	[20]	0 = Not requested, 1 = Requested	0
INT_ADC	[19]	0 = Not requested, 1 = Requested	0
INT_PENDN	[18]	0 = Not requested, 1 = Requested	0
INT_PENUP	[17]	0 = Not requested, 1 = Requested	0
INT_DISP_FIFO	[16]	0 = Not requested, 1 = Requested	0
INT_POST	[15]	0 = Not requested, 1 = Requested	0
INT_BATFLT	[14]	0 = Not requested, 1 = Requested	0
INT_WDT	[13]	0 = Not requested, 1 = Requested	0
INT_TIMER4	[12]	0 = Not requested, 1 = Requested	0
INT_TIMER3	[11]	0 = Not requested, 1 = Requested	0
Reserved	[10:8]	–	–
INT_MSTICK	[7]	0 = Not requested, 1 = Requested	0
INT_IrDA	[6]	0 = Not requested, 1 = Requested	0
INT_ERR1	[5]	0 = Not requested, 1 = Requested	0
INT_TXD1	[4]	0 = Not requested, 1 = Requested	0
INT_RXD1	[3]	0 = Not requested, 1 = Requested	0
INT_ERR0	[2]	0 = Not requested, 1 = Requested	0
INT_TXD0	[1]	0 = Not requested, 1 = Requested	0
INT_RXD0	[0]	0 = Not requested, 1 = Requested	0

**INTERRUPT SUB MASK REGISTER (INTSUBMSK)**

Each of the 32 bits in the interrupt mask register is related to an interrupt source. If you set a specific bit to 1, the interrupt request from the corresponding interrupt source is not serviced by the CPU. (Note that even in such a case, the corresponding bit of SUBSRCPND register is set to 1). If the mask bit is 0, the interrupt request can be serviced.

Register	Address	R/W	Description	Reset Value
INTSUBMSK	0X4020001C	R/W	Determines which interrupt source is masked. The masked interrupt source will not be serviced. 0 = Interrupt service is available 1 = Interrupt service is masked	0x1ffffff

INTSUBMSK	Bit	Description	Initial State
reserved	[31:29]	–	–
INT_DMA3	[28]	0 = Service available, 1 = Masked	1
INT_DMA2	[27]	0 = Service available, 1 = Masked	1
INT_DMA1	[26]	0 = Service available, 1 = Masked	1
INT_DMA0	[25]	0 = Service available, 1 = Masked	1
INT_VLX	[24]	0 = Service available, 1 = Masked	1
INT_SPI1	[23]	0 = Service available, 1 = Masked	1
INT_AC97	[22]	0 = Service available, 1 = Masked	1
INT_NFLASH	[21]	0 = Service available, 1 = Masked	1
INT_DISP_FRAME	[20]	0 = Service available, 1 = Masked	1
INT_ADC	[19]	0 = Service available, 1 = Masked	1
INT_PENDN	[18]	0 = Service available, 1 = Masked	1
INT_PENUP	[17]	0 = Service available, 1 = Masked	1
INT_DISP_FIFO	[16]	0 = Service available, 1 = Masked	1
INT_POST	[15]	0 = Service available, 1 = Masked	1
INT_BATFLT	[14]	0 = Service available, 1 = Masked	1
INT_WDT	[13]	0 = Service available, 1 = Masked	1
INT_TIMER4	[12]	0 = Service available, 1 = Masked	1
INT_TIMER3	[11]	0 = Service available, 1 = Masked	1
Reserved	[10:8]	–	–
INT_MSTICK	[7]	0 = Service available, 1 = Masked	–
INT_IrDA	[6]	0 = Service available, 1 = Masked	–
INT_ERR1	[5]	0 = Service available, 1 = Masked	1
INT_TXD1	[4]	0 = Service available, 1 = Masked	1
INT_RXD1	[3]	0 = Service available, 1 = Masked	1
INT_ERR0	[2]	0 = Service available, 1 = Masked	1
INT_TXD0	[1]	0 = Service available, 1 = Masked	1
INT_RXD0	[0]	0 = Service available, 1 = Masked	1

**VECTORED INTERRUPT MODE REGISTER (VECT\_INT\_MODE)**

This register is used to indicate if the vectored interrupt mode is enabled. If you set a bit[0] to 1, the vectored interrupt mode will be enabled.

Register	Address	R/W	Description	Reset Value
VECT_INT_MODE	0X40200020	R/W	Indicates if the vectored interrupt mode is enabled. 0 = Nonvectored interrupt mode 1 = Vectored interrupt mode	0x00000000

VECT_INT_MODE	Bit	Description	Initial State
reserved	[31:1]	–	–
Vect_int_mode	[0]	0 = Vectored interrupt mode disable 1 = Vectored interrupt mode enable	0

**VECTOR ADDRESS REGISTER (VAR)**

This register is used to provide the interrupt vector address to which the program controls branches. If IRQ occurs, the LDR instruction at 0x0000\_0018 let PC is the value written in this register.

If VECT\_INT\_MODE[0] is set to '0', the address in NONVECT\_ADDR is passed to this register, and if VECT\_INT\_MODE[0] is set to '1', the address in VECT\_ADDR is passed to this register.

Register	Address	R/W	Description	Reset Value
VAR	0X4020002C	R	Provides the interrupt vector address	–

VAR	Bit	Description	Initial State
Var	[31:0]	Provides the interrupt vector address	–



## NOTES

# 7

## PWM TIMER

### OVERVIEW

The S3C24A0A has five 16-bit timers. The timer 0, 1, 2, 3 have PWM function (Pulse Width Modulation). Timer 4 has an internal timer only with no output pins. Timer 0 has a dead-zone generator, which is used with a large current device.

Timer 0 and timer 1 share an 8-bit prescaler, timers 2, 3 and 4 share the other 8-bit prescaler. Each timer has a clock-divider which has 4 different divided signals (1/2, 1/4, 1/8, 1/16). Each timer block receives its own clock signals from the clock-divider, which receives the clock from the corresponding 8-bit prescaler. The 8-bit prescaler is programmable and divides the PCLK according to the loading value, which is stored in TCFG0 and TCFG1 registers.

The timer count buffer register (TCNTBn) has an initial value which is loaded into the down-counter when the timer is enabled. The timer compare buffer register (TCMPBn) has an initial value which is loaded into the compare register to be compared with the down-counter value. This double buffering feature of TCNTBn and TCMPBn makes the timer generate a stable output when the frequency and duty ratio are changed.

Each timer has its own 16-bit down counter, which is driven by the timer clock. When the down counter reaches zero, the timer interrupt request is generated to inform the CPU that the timer operation has been completed. When the timer counter reaches zero, the value of corresponding TCNTBn is automatically loaded into the down counter to continue the next operation. However, if the timer stops, for example, by clearing the timer enable bit of TCONn during the timer running mode, the value of TCNTBn will not be reloaded into the counter.

The value of TCMPBn is used for PWM (pulse width modulation). The timer control logic changes the output level when the down-counter value matches the value of the compare register in the timer control logic. Therefore, the compare register determines the turn-on time(or turn-off time) of an PWM output.

### FEATURE

- Five 16-bit timers
- Two 8-bit prescalers & Two 4-bit divider
- Programmable duty control of output waveform (PWM)
- Auto-reload mode or one-shot pulse mode
- Dead-zone generator



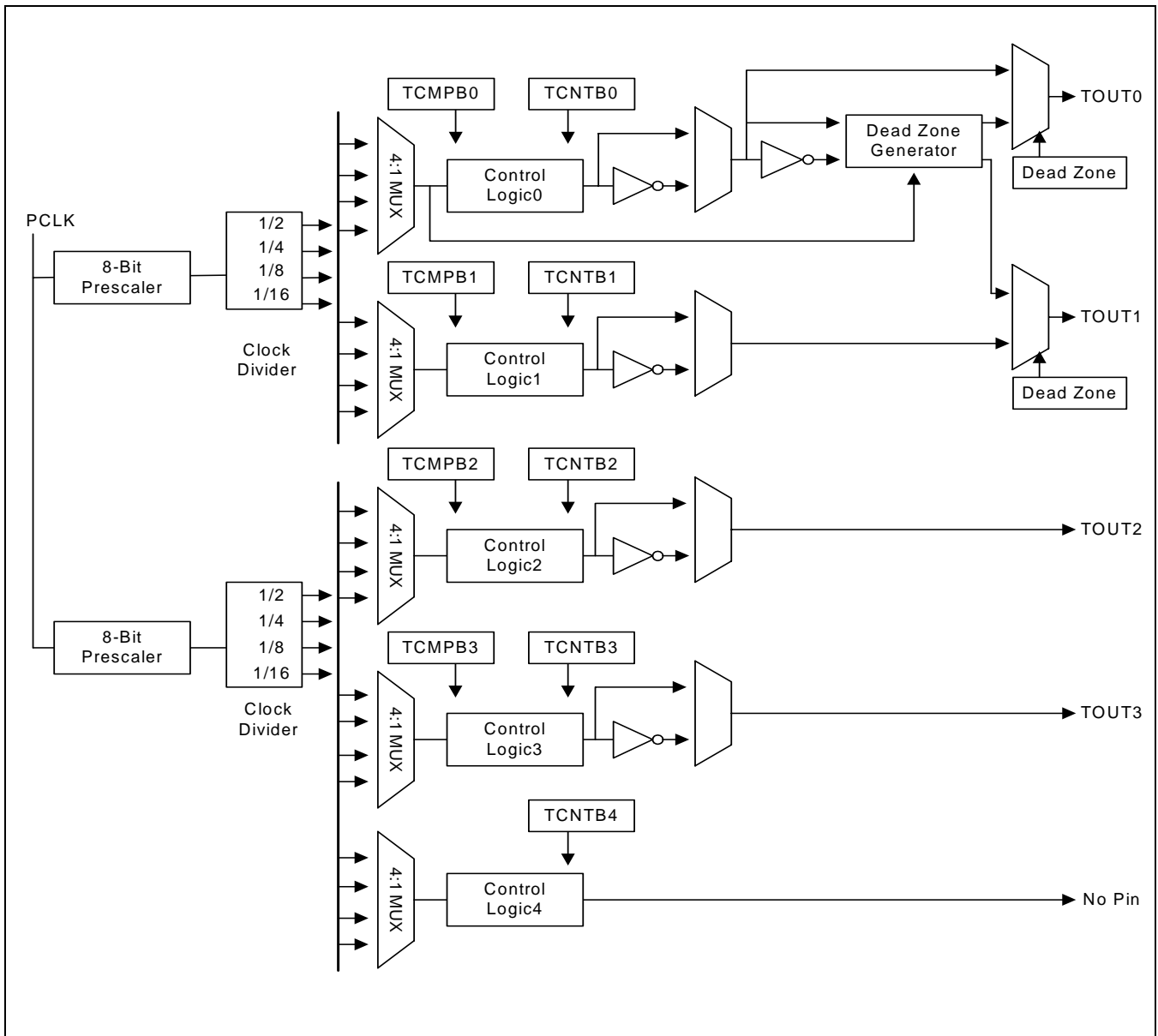

Figure 7-1. 16-bit PWM Timer Block Diagram

## PWM TIMER OPERATION

### PRESCALER & DIVIDER

An 8-bit prescaler and 4-bit divider has the following output frequencies:

4-bit Divider Settings	Minimum Resolution (prescaler = 0)	Maximum Resolution (prescaler = 255)	Maximum Interval (TCNTBn = 65535)
1/2 ( PCLK = 55 MHz )	0.0363 us (27.5000 MHz )	9.3090 us (107.4219 kHz )	0.6100 sec
1/4 ( PCLK = 55 MHz )	0.0727 us (13.7500 MHz )	18.6181 us (53.7109 kHz )	1.2201 sec
1/8 ( PCLK = 55 MHz )	0.1454us ( 6.8750 MHz )	37.2363 us (26.8554 kHz )	2.4403 sec
1/16 ( PCLK = 55 MHz )	0.2909 us ( 3.4375 MHz )	74.4729 us (13.4277 kHz )	4.8806 sec

### BASIC TIMER OPERATION

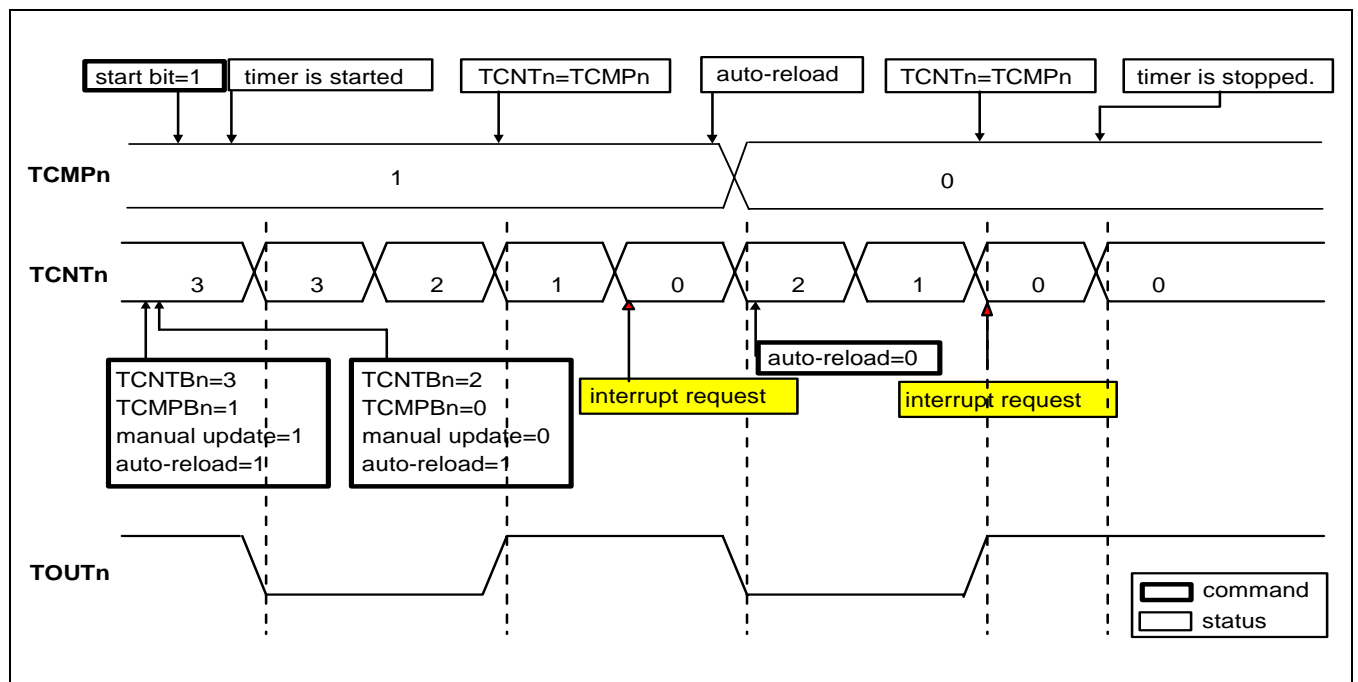

Figure 7-2. Timer operations

A timer (except the timer ch-5) has TCNTBn, TCNTn, TCMPBn and TCMPn. TCNTBn and TCMPBn are loaded into TCNTn and TCMPn when the timer reaches 0. When TCNTn reaches 0, the interrupt request will occur if the interrupt is enabled. (TCNTn and TCMPn are the names of the internal registers. The TCNTn register can be read from the TCNTOn register)



### AUTO-RELOAD & DOUBLE BUFFERING

S3C24A0A PWM Timers have a double buffering feature, which can change the reload value for the next timer operation without stopping the current timer operation. So, although the new timer value is set, a current timer operation is completed successfully.

The timer value can be written into TCNTBn (Timer Count Buffer register) and the current counter value of the timer can be read from TCNTOn (Timer Count Observation register). If TCNTBn is read, the read value is not the current state of the counter but the reload value for the next timer duration.

The auto-reload is the operation, which copies the TCNTBn into TCNTn when TCNTn reaches 0. The value, written into TCNTBn, is loaded to TCNTn only when the TCNTn reaches to 0 and auto-reload is enabled. If the TCNTn is 0 and the auto-reload bit is 0, the TCNTn does not operate any further.

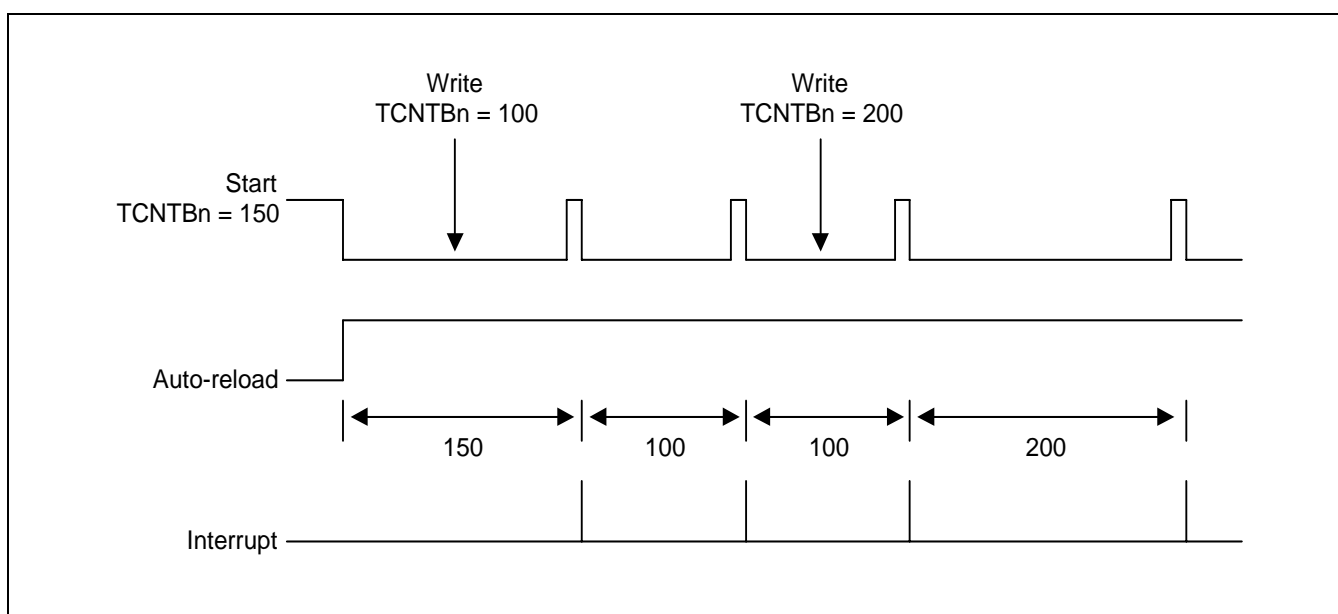

Figure 7-3. Example of Double Buffering Feature

### TIMER INITIALIZATION USING MANUAL UPDATE BIT AND INVERTER BIT

Because an auto-reload operation of the timer occurs when the down counter reaches to 0, a starting value of the TCNTn has to be defined by the user at first. In this case, the starting value has to be loaded by the manual update bit. The sequence of starting a timer is as follows;

1. Write the initial value into TCNTBn and TCMPBn
2. Set the manual update bit of the corresponding timer. It is recommended to configure the inverter on/off bit. (whether use inverter or not)
3. Set start bit of corresponding timer to start the timer (At the same time, clear the manual update bit).

Also, if the timer is stopped by force, the TCNTn retains the counter value and is not reloaded from TCNTBn. If new value has to be set, manual update has to be done.

**NOTE**

Whenever TOUT inverter on/off bit is changed, the TOUTn logic value will be changed whether or not the timer runs. Therefore, it is desirable that the inverter on/off bit is configured with the manual update bit.

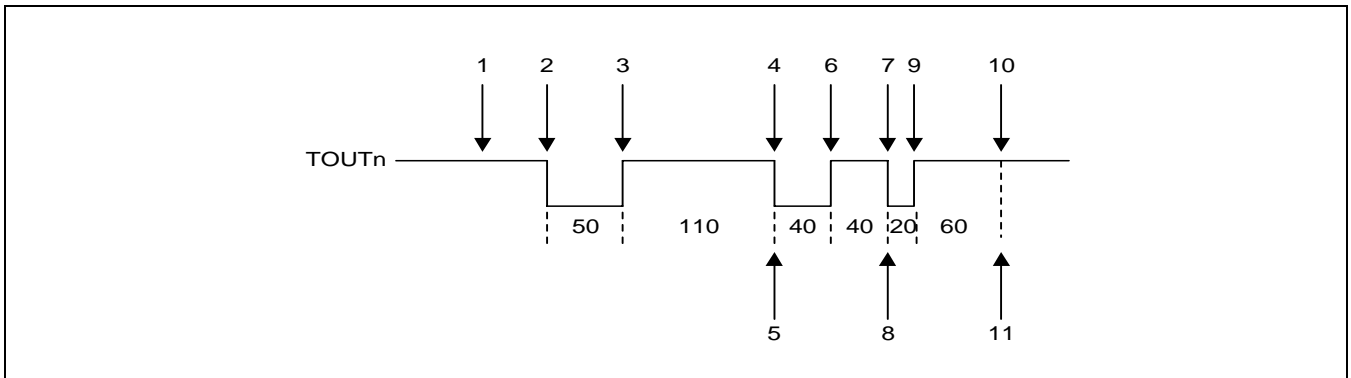
**EXAMPLE OF A TIMER OPERATION**

**Figure 7-4. Example of a Timer Operation**

The result of the following procedure is shown in Figure21-4;

1. Enable the auto-reload feature. Set the TCNTBn as 160 (50+110) and the TCMPBn as 110. Set the manual update bit and configure the inverter bit(on/off). The manual update bit sets TCNTn and TCMPn to the values of TCNTBn and TCMPBn, respectively.  
And then, set TCNTBn and TCMPBn as 80 (40+40) and 40, respectively, to determine the next reload value.
2. Set the start bit, provided that manual\_update is 0 and inverter is off and auto-reload is on. The timer starts counting down after latency time within the timer resolution.
3. When TCNTn has the same value with TCMPn, the logic level of TOUTn is changed from low to high.
4. When TCNTn reaches 0, the interrupt request is generated and TCNTBn value is loaded into a temporary register. At the next timer tick, TCNTn is reloaded with the temporary register value(TCNTBn).
5. In the ISR(Interrupt Service Routine), the TCNTBn and TCMPBn are set as 80 (20+60) and 60, respectively, which is used for the next duration.
6. When TCNTn has the same value as TCMPn, the logic level of TOUTn is changed from low to high.
7. When TCNTn reaches 0, TCNTn is reloaded automatically with TCNTBn. At the same time, the interrupt request is generated.
8. In the ISR (Interrupt Service Routine), auto-reload and interrupt request are disabled to stop the timer.
9. When the value of TCNTn is same as TCMPn, the logic level of TOUTn is changed from low to high.
10. Even when TCNTn reaches to 0, TCNTn is not any more reloaded and the timer is stopped because auto-reload has been disabled.
11. No interrupt request is generated.

**PWM (PULSE WIDTH MODULATION)**

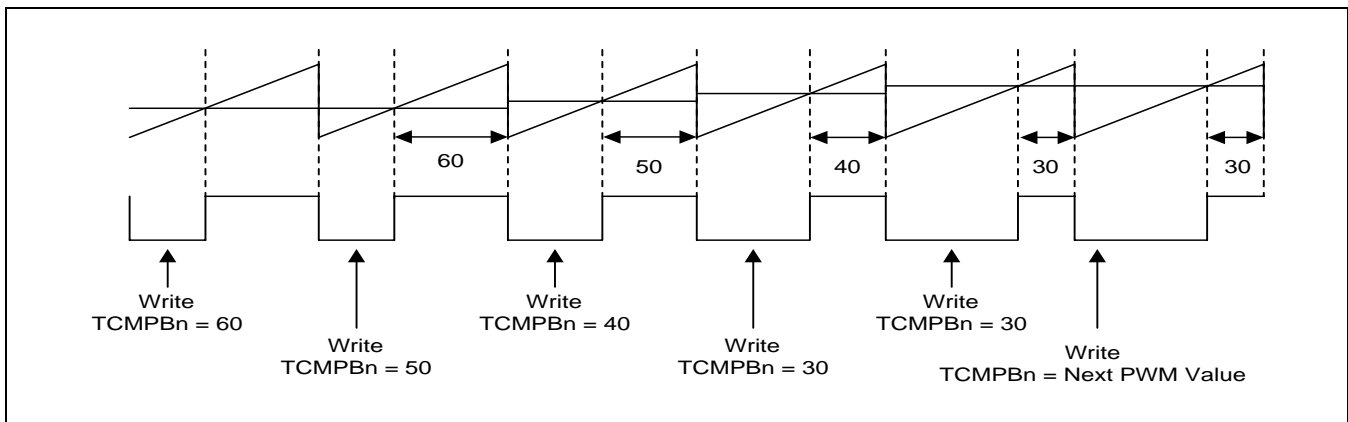

**Figure 7-5. Example of PWM**

PWM feature can be implemented by using the TCMPBn. PWM frequency is determined by TCNTBn. A PWM value is determined by TCMPBn in Figure 7-5.

For a higher PWM value, decrease the TCMPBn value. For a lower PWM value, increase the TCMPBn value. If an output inverter is enabled, the increment/decrement may be reversed.

Because of the double buffering feature, TCMPBn, for a next PWM cycle, can be written at any point in the current PWM cycle by ISR or something else

## OUTPUT LEVEL CONTROL

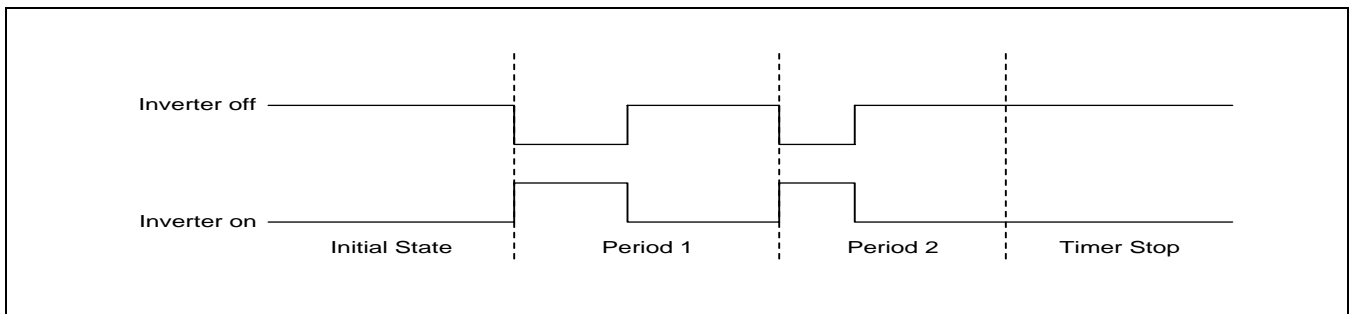

Figure 7-6. Inverter On/Off

The following methods can be used to maintain TOUT as high or low.(assume the inverter is off)

1. Turn off the auto-reload bit. And then, TOUTn goes to high level and the timer is stopped after TCNTn reaches to 0. This method is recommended.
2. Stop the timer by clearing the timer start/stop bit to 0. If  $TCNTn \leq TCMPn$ , the output level is high. If  $TCNTn > TCMPn$ , the output level is low.
3. TOUTn can be inverted by the inverter on/off bit in TCON. The inverter removes the additional circuit to adjust the output level.



**DEAD ZONE GENERATOR**

The dead zone is for the PWM control in a power device. This feature is used to insert the time gap between a turn-off of a switching device and a turn on of another switching device. This time gap prohibits the two switching devices turning on simultaneously, even for a very short time.

TOUT0 is the PWM output. nTOUT0 is the inversion of the TOUT0. If the dead zone is enabled, the output wave form of TOUT0 and nTOUT0 will be TOUT0\_DZ and nTOUT0\_DZ, respectively. nTOUT0\_DZ is routed to the TOUT1 pin.

In the dead zone interval, TOUT0\_DZ and nTOUT0\_DZ can never be turned on simultaneously.

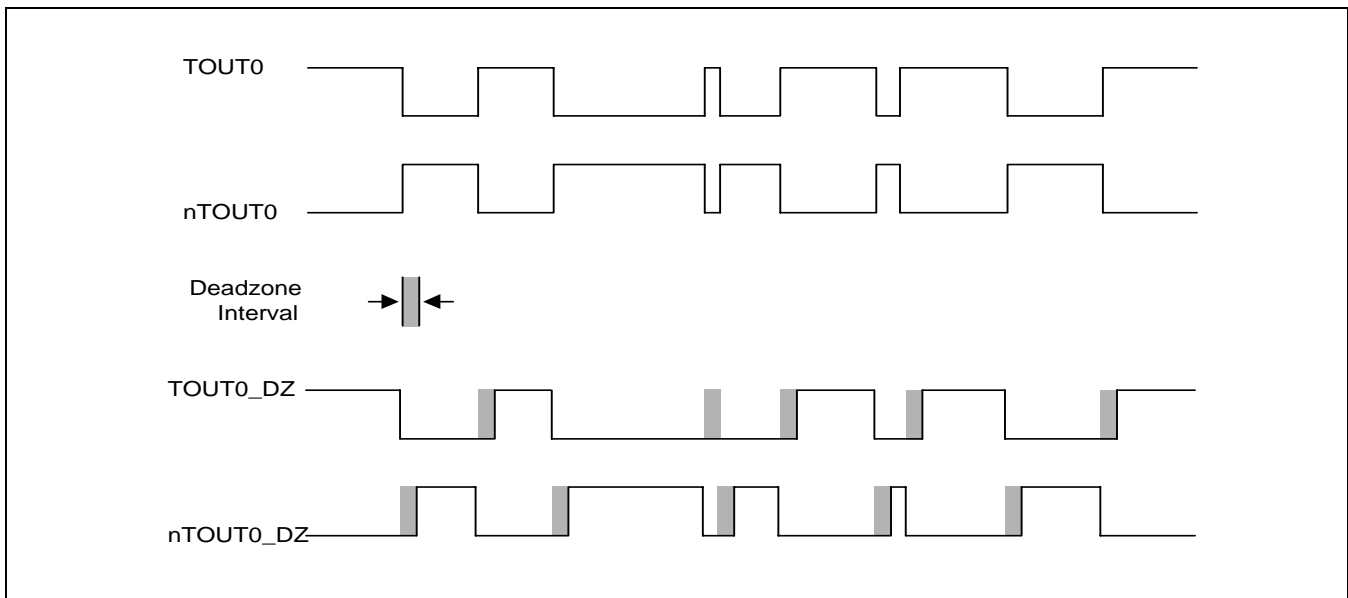

**Figure 7-7. The Wave Form When a Dead Zone Feature is Enabled**

## DMA REQUEST MODE

The PWM timer can generate a DMA request at every specific times. The timer keeps DMA request signal (nDMA\_REQ) low until the timer receives the ACK signal. When the timer receives the ACK signal, it makes the request signal inactive. The timer, which generates the DMA request, is determined by setting DMA mode bits(in TCFG1 register). If one of timers is configured as DMA request mode, that timer does not generate an interrupt request. The others can generate interrupt normally.

DMA mode configuration and DMA / interrupt operation

DMA Mode	DMA Request	Timer0 INT	Timer1 INT	Timer2 INT	Timer3 INT	Timer4 INT
0000	No select	ON	ON	ON	ON	ON
0001	Timer0	OFF	ON	ON	ON	ON
0010	Timer1	ON	OFF	ON	ON	ON
0011	Timer2	ON	ON	OFF	ON	ON
0100	Timer3	ON	ON	ON	OFF	ON
0101	Timer4	ON	ON	ON	ON	OFF
0110	No select	ON	ON	ON	ON	ON

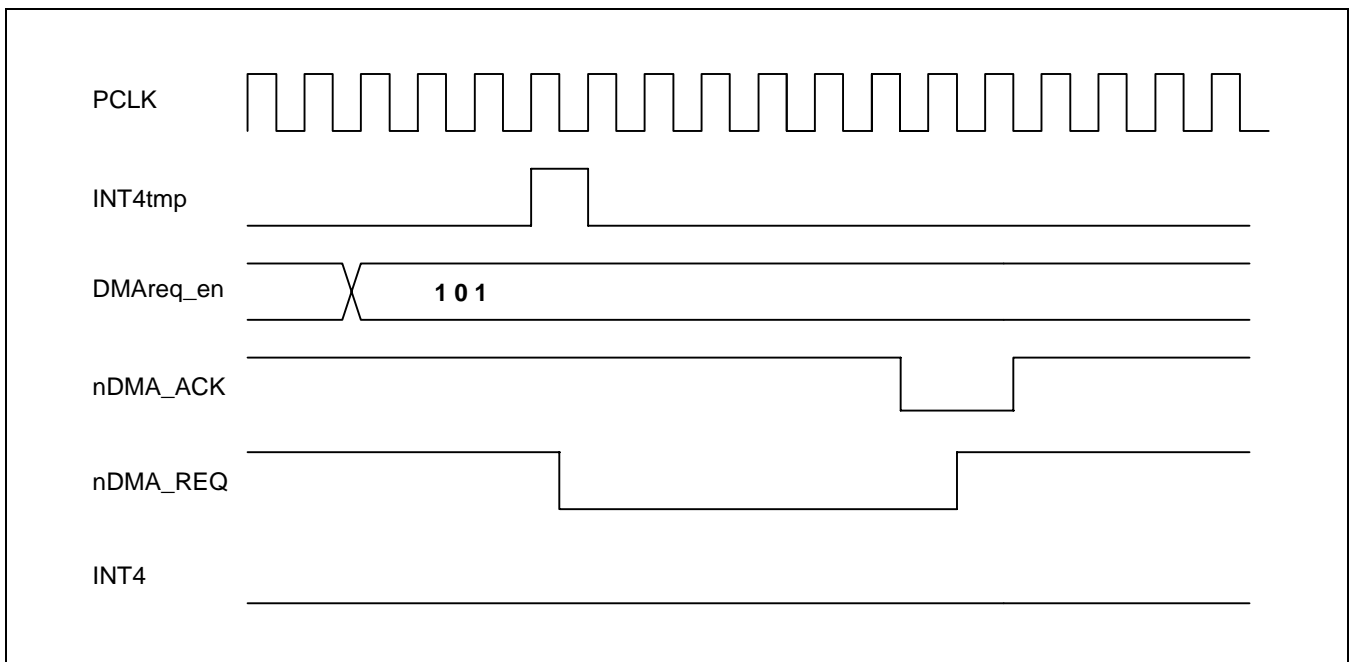

Figure 7-8. The Timer4 DMA Mode Operation

## PWM TIMER CONTROL REGISTERS

### TIMER CONFIGURATION REGISTER0 (TCFG0)

Timer input clock Frequency =  $PCLK / \{prescaler\ value + 1\} / \{divider\ value\}$   
 {prescaler value} = 0 ~ 255  
 {divider value} = 2, 4, 8, 16

Register	Address	R/W	Description	Reset Value
TCFG0	0x44000000	R/W	Configures the two 8-bit prescalers	0x00000000

TCFG0	Bit	Description	Initial State
Reserved	[31:24]	–	0x00
Dead zone length	[23:16]	These 8 bits determine the dead zone length. The 1 unit time of the dead zone length is equal to the 1 unit time of timer 0.	0x00
Prescaler 1	[15:8]	These 8 bits determine prescaler value for Timer 2, 3 and 4	0x00
Prescaler 0	[7:0]	These 8 bits determine prescaler value for Timer 0 and 1	0x00

**TIMER CONFIGURATION REGISTER1 (TCFG1)**

Register	Address	R/W	Description	Reset Value
TCFG1	0x44000004	R/W	5-MUX & DMA mode selecton register	0x00000000

TCFG1	Bit	Description	Initial State
Reserved	[31:24]	–	00000000
DMA mode	[23:20]	Select DMA request channel 0000 = No select(All interrupt) 0001 = Timer0 0010 = Timer1 0011 = Timer2 0100 = Timer3 0101 = Timer4 0110 = Reserved	0000
MUX 4	[19:16]	Select MUX input for PWM Timer 4. 0000 = 1/2 0001 = 1/4 0010 = 1/8 0011 = 1/16	0000
MUX 3	[15:12]	Select MUX input for PWM Timer 3. 0000 = 1/2 0001 = 1/4 0010 = 1/8 0011 = 1/16	0000
MUX 2	[11:8]	Select MUX input for PWM Timer 2. 0000 = 1/2 0001 = 1/4 0010 = 1/8 0011 = 1/16	0000
MUX 1	[7:4]	Select MUX input for PWM Timer 1. 0000 = 1/2 0001 = 1/4 0010 = 1/8 0011 = 1/16	0000
MUX 0	[3:0]	Select MUX input for PWM Timer 0. 0000 = 1/2 0001 = 1/4 0010 = 1/8 0011 = 1/16	0000



## TIMER CONTROL REGISTER (TCON)

Register	Address	R/W	Description	Reset Value
TCON	0x44000008	R/W	Timer control register	0x00000000

TCON	Bit	Description	initial state
Timer 4 auto reload on/off	[22]	This bit determines auto reload on/off for Timer 4. 0 = One-shot      1 = Interval mode (auto reload)	0
Timer 4 manual update <sup>(note)</sup>	[21]	This bit determines the manual update for Timer 4. 0 = No operation      1 = Update TCNTB4	0
Timer 4 start/stop	[20]	This bit determines start/stop for Timer 4. 0 = Stop      1 = Start for Timer 4	0
Timer 3 auto reload on/off	[19]	This bit determines auto reload on/off for Timer 3. 0 = One-shot      1 = Interval mode (auto reload)	0
Timer 3 output inverter on/off	[18]	This bit determines output inverter on/off for Timer3. 0 = Inverter off      1 = Inverter on for TOUT3	0
Timer 3 manual update <sup>(note)</sup>	[17]	This bit determine manual update for Timer 3. 0 = No operation      1 = Update TCNTB3, TCMPB3	0
Timer 3 start/stop	[16]	This bit determines start/stop for Timer 3. 0 = Stop      1 = Start for Timer 3	0
Timer 2 auto reload on/off	[15]	This bit determines auto reload on/off for Timer 2. 0 = One-shot      1 = Interval mode (auto reload)	0
Timer 2 output inverter on/off	[14]	This bit determines output inverter on/off for Timer2. 0 = Inverter off      1 = Inverter on for TOUT2	0
Timer 2 manual update <sup>(note)</sup>	[13]	This bit determines the manual update for Timer 2. 0 = No operation      1 = Update TCNTB2, TCMPB2	0
Timer 2 start/stop	[12]	This bit determines start/stop for Timer 2. 0 = Stop      1 = Start for Timer 2	0
Timer 1 auto reload on/off	[11]	This bit determines the auto reload on/off for Timer 1. 0 = One-shot      1 = Interval mode (auto reload)	0
Timer 1 output inverter on/off	[10]	This bit determines the output inverter on/off for Timer 1. 0 = Inverter off      1 = Inverter on for TOUT1	0
Timer 1 manual update <sup>(note)</sup>	[9]	This bit determines the manual update for Timer 1. 0 = No operation      1 = Update TCNTB1, TCMPB1	0
Timer 1 start/stop	[8]	This bit determines start/stop for Timer 1. 0 = Stop      1 = Start for Timer 1	0
Reserved	[7:5]	—	—

**NOTE:** This bit has to be cleared at next writing.

**TIMER CONTROL REGISTER (TCON) (Continued)**

TCON	Bit	Description	Initial State
Dead zone enable	[4]	This bit determines the dead zone operation. 0 = Disable      1 = Enable	0
Timer 0 auto reload on/off	[3]	This bit determines auto reload on/off for Timer 0. 0 = One-shot      1 = Interval mode(auto reload)	0
Timer 0 output inverter on/off	[2]	This bit determines the output inverter on/off for Timer 0. 0 = Inverter off      1 = Inverter on for TOUT0	0
Timer 0 manual update <sup>(note)</sup>	[1]	This bit determines the manual update for Timer 0. 0 = No operation      1 = Update TCNTB0, TCMPB0	0
Timer 0 start/stop	[0]	This bit determines start/stop for Timer 0 0 = Stop      1 = Start for Timer 0	0

**NOTE:** This bit has to be cleared at next writing.  
Timer 0 Count Buffer Register & Compare Buffer Register (TCNTB0, TCMPB0)

Register	Address	R/W	Description	Reset Value
TCNTB0	0x4400000C	R/W	Timer 0 count buffer register	0x00000000
TCMPB0	0x44000010	R/W	Timer 0 compare buffer register	0x00000000

TCMPB0	Bit	Description	Initial State
Timer 0 compare buffer register	[15:0]	Setting compare buffer value for Timer 0	0x00000000

TCNTB0	Bit	Description	Initial State
Timer 0 count buffer register	[15:0]	Setting count buffer value for Timer 0	0x00000000

**TIMER 0 COUNT OBSERVATION REGISTER (TCNTO0)**

Register	Address	R/W	Description	Reset Value
TCNTO0	0x44000014	R	Timer 0 count observation register	0x00000000

TCNTO0	Bit	Description	Initial State
Timer 0 observation register	[15:0]	Setting count observation value for Timer 0	0x00000000



**TIMER 1 COUNT BUFFER REGISTER & COMPARE BUFFER REGISTER (TCNTB1, TCMPB1)**

Register	Address	R/W	Description	Reset Value
TCNTB1	0x44000018	R/W	Timer 1 count buffer register	0x00000000
TCMPB1	0x4400001C	R/W	Timer 1 compare buffer register	0x00000000

TCMPB1	Bit	Description	Initial State
Timer 1 compare buffer register	[15:0]	Setting compare buffer value for Timer 1	0x00000000

TCNTB1	Bit	Description	Initial State
Timer 1 count buffer register	[15:0]	Setting count buffer value for Timer 1	0x00000000

**TIMER 1 COUNT OBSERVATION REGISTER(TCNTO1)**

Register	Address	R/W	Description	Reset Value
TCNTO1	0x44000020	R	Timer 1 count observation register	0x00000000

TCNTO1	Bit	Description	initial state
Timer 1 observation register	[15:0]	Setting count observation value for Timer 1	0x00000000

**TIMER 2 COUNT BUFFER REGISTER & COMPARE BUFFER REGISTER (TCNTB2, TCMPB2)**

Register	Address	R/W	Description	Reset Value
TCNTB2	0x44000024	R/W	Timer 2 count buffer register	0x00000000
TCMPB2	0x44000028	R/W	Timer 2 compare buffer register	0x00000000

TCMPB2	Bit	Description	Initial State
Timer 2 compare buffer register	[15:0]	Setting compare buffer value for Timer 2	0x00000000

TCNTB2	Bit	Description	Initial State
Timer 2 count buffer register	[15:0]	Setting count buffer value for Timer 2	0x00000000

**TIMER 2 COUNT OBSERVATION REGISTER (TCNTO2)**

Register	Address	R/W	Description	Reset Value
TCNTO2	0x4400002C	R	Timer 2 count observation register	0x00000000

TCNTO2	Bit	Description	Initial State
Timer 2 observation register	[15:0]	Setting count observation value for Timer 2	0x00000000





**TIMER 3 COUNT BUFFER REGISTER & COMPARE BUFFER REGISTER (TCNTB3, TCMPB3)**

Register	Address	R/W	Description	Reset Value
TCNTB3	0x44000030	R/W	Timer 3 count buffer register	0x00000000
TCMPB3	0x44000034	R/W	Timer 3 compare buffer register	0x00000000

TCMPB3	Bit	Description	Initial State
Timer 3 compare buffer register	[15:0]	Setting compare buffer value for Timer 3	0x00000000

TCNTB3	Bit	Description	Initial State
Timer 3 count buffer register	[15:0]	Setting count buffer value for Timer 3	0x00000000

**TIMER 3 COUNT OBSERVATION REGISTER (TCNTO3)**

Register	Address	R/W	Description	Reset Value
TCNTO3	0x44000038	R	Timer 3 count observation register	0x00000000

TCNTO3	Bit	Description	Initial State
Timer 3 observation register	[15:0]	Setting count observation value for Timer 3	0x00000000

**TIMER 4 COUNT BUFFER REGISTER (TCNTB4)**

Register	Address	R/W	Description	Reset Value
TCNTB4	0x4400003C	R/W	Timer 4 count buffer register	0x00000000

TCNTB4	Bit	Description	Initial State
Timer 4 count buffer register	[15:0]	Setting count buffer value for Timer 4	0x00000000

**TIMER 4 COUNT OBSERVATION REGISTER (TCNTO4)**

Register	Address	R/W	Description	Reset Value
TCNTO4	0x44000040	R	Timer 4 count observation register	0x00000000

TCNTO4	Bit	Description	Initial State
Timer 4 observation register	[15:0]	Setting count observation value for Timer 4	0x00000000



## NOTES

# 8

## WATCHDOG TIMER

### OVERVIEW

The S3C24A0A watchdog timer is used to resume the controller operation when it had been disturbed by malfunctions such as noise and system errors. It can be used as a normal 16-bit interval timer to request interrupt service. The watchdog timer generates the reset signal for 128 PCLK cycles.

### FEATURES

- Normal interval timer mode with interrupt request
- Internal reset signal is activated for 128 PCLK cycles when the timer count value reaches 0(time-out).



## WATCHDOG TIMER OPERATION

The functional block diagram of the watchdog timer is shown in Figure 8-1. The watchdog timer uses PCLK as its only source clock. To generate the corresponding watchdog timer clock, the PCLK frequency is prescaled first, and the resulting frequency is divided again.

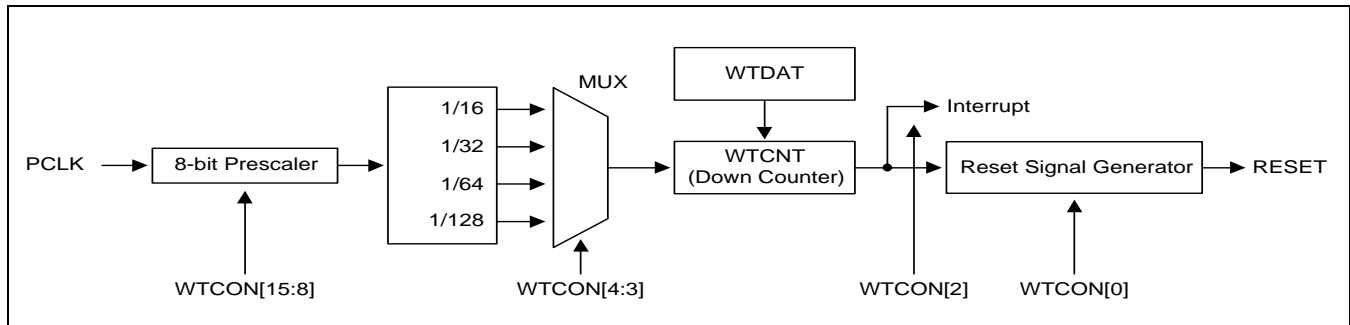

**Figure 8-1. Watchdog Timer Block Diagram**

The prescaler value and the frequency division factor are specified in the watchdog timer control register, WTCON. The valid prescaler values range from 0 to  $2^8-1$ . The frequency division factor can be selected as 16, 32, 64, or 128.

Use the following equation to calculate the watchdog timer clock frequency and the duration of each timer clock cycle:

$$t_{\text{watchdog}} = 1 / (PCLK / (\text{Prescaler value} + 1) / \text{Division\_factor})$$

## WTDAT & WTCNT

When the watchdog timer is enabled first, the value of WTDAT (watchdog timer data register) cannot be automatically reloaded into the WTCNT (timer counter). For this reason, an initial value must be written to the watchdog timer count register, WTCNT, before the watchdog timer starts.

## CONSIDERATION OF DEBUGGING ENVIRONMENT

When S3C24A0A is in debug mode using Embedded ICE, the watchdog timer must not operate.

The watchdog timer can determine whether or not the current mode is the debug mode from the CPU core signal (DBGACK signal). Once the DBGACK signal is asserted, the reset output of the watchdog timer is not activated when the watchdog timer is expired.

## WATCHDOG TIMER SPECIAL REGISTERS

### WATCHDOG TIMER CONTROL REGISTER (WTCON)

Using the Watchdog Timer Control register, WTCON, you can enable/disable the watchdog timer, select the clock signal from 4 different sources, enable/disable interrupts, and enable/disable the watchdog timer output.

The Watchdog timer is used to resume the S3C24A0A restart on mal-function after power-on; if controller restart is not desired, the Watchdog timer should be disabled.

If the user wants to use the normal timer provided by the Watchdog timer, please enable the interrupt and disable the Watchdog timer.

Register	Address	R/W	Description	Reset Value
WTCON	0x44100000	R/W	Watchdog timer control register	0x8021

WTCON	Bit	Description	Initial State
Prescaler value	[15:8]	The prescaler value The valid range is from 0 to $(2^8-1)$	0x80
Reserved	[7:6]	Reserved. These two bits must be 00 in normal operation.	00
Watchdog timer	[5]	Enable or disable bit of Watchdog timer. 0 = Disable 1 = Enable	1
Clock select	[4:3]	This two bits determines the clock division factor 00 = 16                      01 = 32 10 = 64                      11 = 128	00
Interrupt generation	[2]	Enable or disable bit of the interrupt. 0 = Disable 1 = Enable	0
Reserved	[1]	Reserved. This bit must be 0 in normal operation	0
Reset enable/disable	[0]	Enable or disable bit of Watchdog timer output for reset signal 1 = Asserts reset signal of the S3C24A0A at watchdog time-out 0 = Disables the reset function of the watchdog timer.	1



**WATCHDOG TIMER DATA REGISTER (WTDAT)**

The watchdog timer data register, WTDAT is used to specify the time-out duration. The content of WTDAT can not be automatically loaded into the timer counter at initial watchdog timer operation. However, the first time-out occurs by using 0x8000(initial value), after then the value of WTDAT will be automatically reloaded into WTCNT.

Register	Address	R/W	Description	Reset Value
WTDAT	0x44100004	R/W	Watchdog timer data Register	0x8000

WTDAT	Bit	Description	Initial State
count reload value	[15:0]	Watchdog timer count value for reload.	0x8000

**WATCHDOG TIMER COUNT REGISTER (WTCNT)**

The watchdog timer count register, WTCNT, contains the current count values for the watchdog timer during normal operation. Note that the content of the watchdog timer data register cannot be automatically loaded into the timer count register when the watchdog timer is enabled initially, so the watchdog timer count register must be set to an initial value before enabling it.

Register	Address	R/W	Description	Reset Value
WTCNT	0x44100008	R/W	Watchdog timer count Register	0x8000

WTCNT	Bit	Description	Initial State
Count value	[15:0]	The current count value of the watchdog timer	0x8000

# 9

## DMA

### OVERVIEW

S3C24A0A supports four-channel DMA ( Bridge DMA or peripheral DMA) controller that is located between the system bus and the peripheral bus. Each channel of DMA controller can perform data movements between devices in the system bus and/or peripheral bus with no restrictions. In other words, each channel can handle the following four cases: 1) both source and destination are in the system bus, 2) source is in the system bus while destination is in the peripheral bus, 3) source is in the peripheral bus while destination is in the system bus, 4) both source and destination are in the peripheral bus.

The main advantage of DMA is that it can transfer the data without CPU intervention. The operation of DMA can be initiated by S/W, the request from internal peripherals or the external request pins.

### DMA REQUEST SOURCES

Each channel of DMA controller can select one of DMA request source among four DMA sources if H/W DMA request mode is selected by DCON register. (Note that if S/W request mode is selected, this DMA request sources have no meaning at all.) The four DMA sources for each channel are as follows.

**Table 9-1. DMA Request Sources for Each Channel**

	Source0	Source1	Source2	Source3	Source4	Source5	Source6	Source7
<b>Ch-0</b>	XDREQ0	UART0	I2SSDI	PWM Timer	USB device EP1	AC97_ PCMout	MSTICK	IrDA
<b>Ch-1</b>	XDREQ1	UART1	I2SSDO	SPI0	USB device EP2	AC97_ PCMin	AC97_PC Mout	IrDA
<b>Ch-2</b>	UART0	I2SSDO	SDMMC	PWM Timer	USB device EP3	AC97_ MICin	AC97_PC Min	Reserved
<b>Ch-3</b>	UART1	SDMMC	SPI1	Timer	USB device EP4	MSTICK	AC97_MI Cin	Reserved

Here, nXDREQ0 and nXDREQ1 represent two external sources(External Devices), and I2SSDO and I2SSDI represent IIS transmitting and receiving, respectively.



## DMA OPERATION

The details of DMA operation can be explained using three-state FSM(finite state machine) as follows:

<b>State-1.</b>	As an initial state, it waits for the DMA request. If it comes, go to state-2. At this state, DMA ACK and INT REQ are 0.
<b>State-2.</b>	In this state, DMA ACK becomes 1 and the counter(CURR_TC) is loaded from DCON[19:0] register. Note that DMA ACK becomes 1 and remains 1 until it is cleared later.
<b>State-3.</b>	<p>In this state, sub-FSM handling the atomic operation of DMA is initiated. The sub-FSM reads the data from the source address and then writes it to destination address. In this operation, data size and transfer size (single or burst) are considered. This operation is repeated until the counter (CURR_TC) becomes 0 in the whole service mode, while performed only once in a single service mode. The main FSM (this FSM) counts down the CURR_TC when the sub-FSM finishes each of atomic operation. In addition, this main FSM asserts the INT REQ signal when CURR_TC becomes 0 and the interrupt setting of DCON[28] register is set to 1. In addition, it clears DMA ACK if one of the following conditions are met.</p> <ol style="list-style-type: none"> <li>1. CURR_TC becomes 0 in the whole service mode</li> <li>2. Atomic operation finishes in the single service mode.</li> </ol>

Note that in the single service mode, these three states of main FSM are performed and then stops, and waits for another DMA REQ. And if DMA REQ comes in all three states are repeated. Therefore, DMA ACK is asserted and then de-asserted for each atomic transfer. In contrast, in the whole service mode, main FSM waits at state-3 until CURR\_TC becomes 0. Therefore, DMA ACK is asserted during all the transfers and then de-asserted when TC reaches 0.

However, INT REQ is asserted only if CURR\_TC becomes 0 regardless of the service mode (single service mode or whole service mode).

## EXTERNAL DMA DREQ/DACK PROTOCOL

There are four types of external DMA request/acknowledge protocols. Each type defines how the signals like DMA request and acknowledge are related to these protocols.

### Basic DMA Timing

The DMA service means paired Reads and Writes cycles during DMA operation, which is one DMA operation. The Figure 9-1 shows the basic Timing in the DMA operation of the S3C24A0A.

- The setup time and the delay time of XDREQ and XDACK are same in all the modes.
- If the completion of XDREQ meets its setup time, it is synchronized twice and then XDACK is asserted.
- After assertion of XDACK, DMA requests the bus and if it gets the bus it performs its operations. XDACK is deasserted when DMA operation finishes.

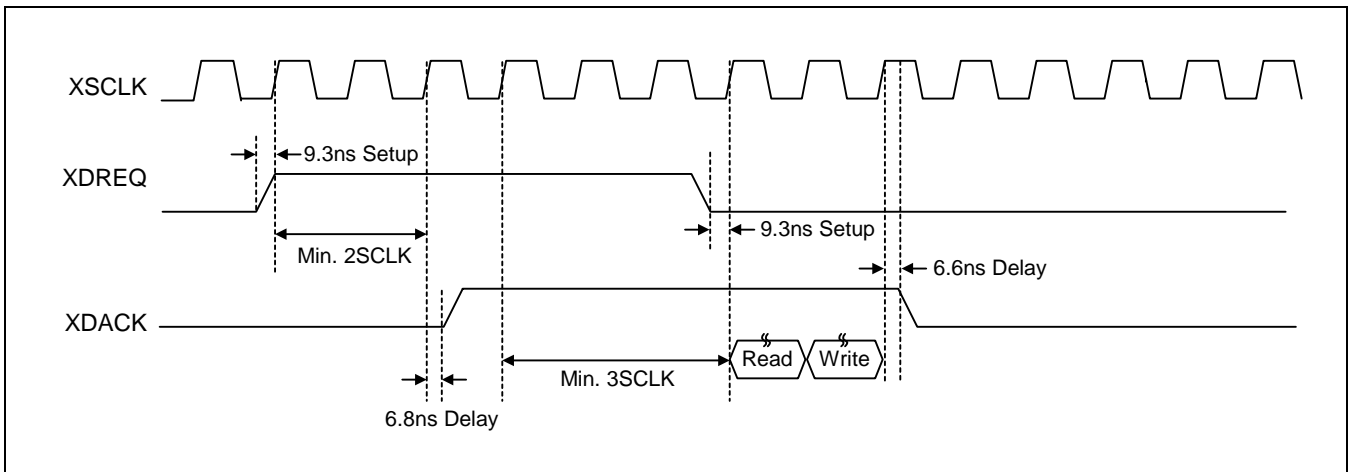

Figure 9-1. Basic DMA Timing Diagram

Demand/Handshake Mode Comparison – Related to the Protocol between XDREQ and XDACK

These are two different modes related to the protocol between XDREQ and XDACK. Figure 8-2 shows the differences between these two modes i.e., Demand and Handshake modes.

At the end of one transfer(Single/Burst transfer), DMA checks the state of double-synched XDREQ.

**Demand Mode**

- If XDREQ remains asserted, the next transfer starts immediately. Otherwise it waits for XDREQ to be asserted.

**Handshake Mode**

- If XDREQ is deasserted, DMA deasserts XDACK in 2cycles. Otherwise it waits until XDREQ is deasserted.

**Caution:** XDREQ has to be asserted (low) only after the deassertion(high) of XDACK.

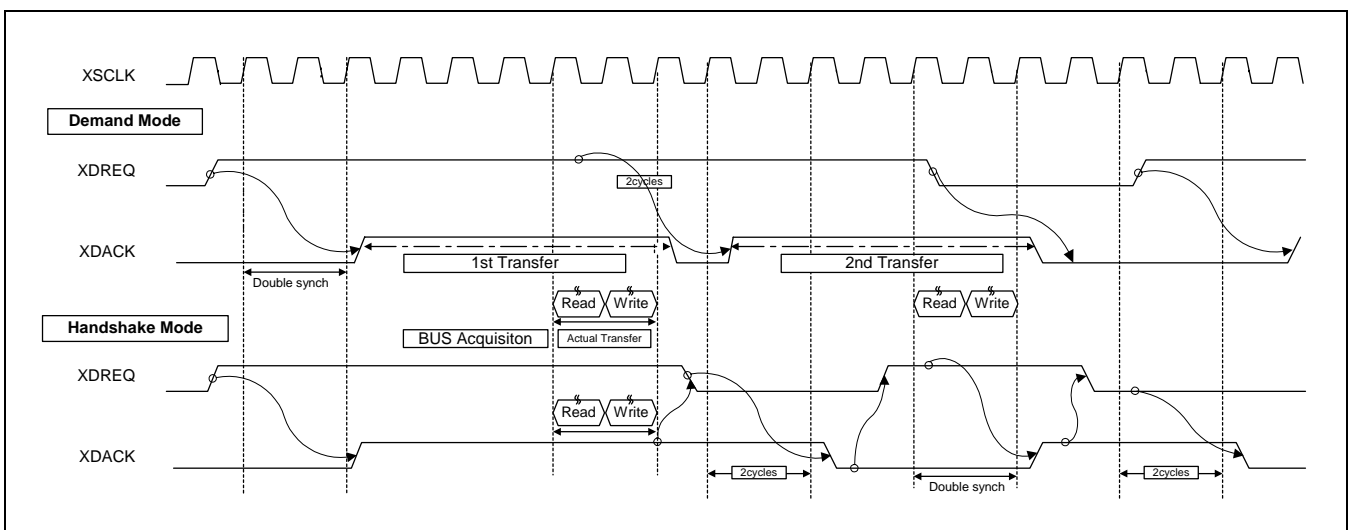

Figure 9-2. Demand/Handshake Mode Comparison

### Transfer Size

- There are two different transfer sizes; single and Burst 4.
- DMA holds the bus firmly during the transfer of these chunk of data, thus other bus masters can not get the bus.

### Burst 4 Transfer Size

4 sequential Reads and 4 sequential Writes are performed in the Burst 4 Transfer.

#### NOTE

Single Transfer size: One read and one write are performed.

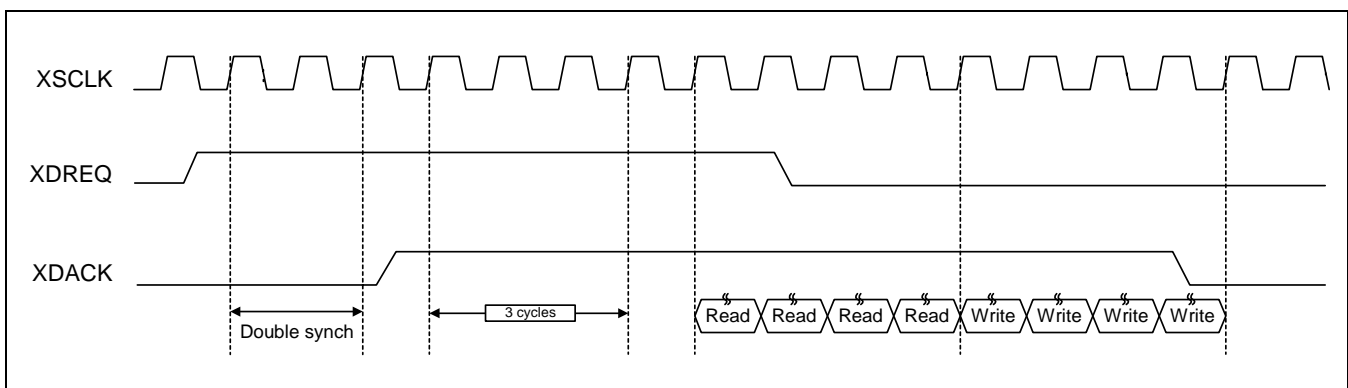
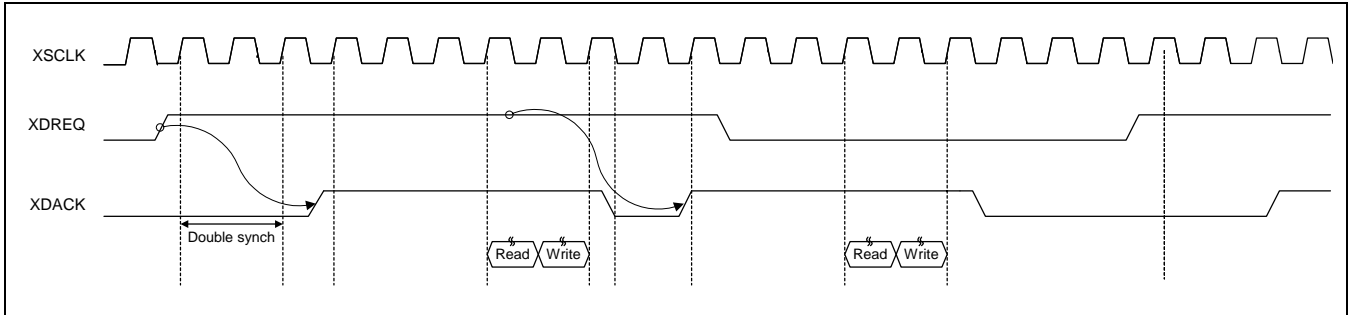

Figure 9-3. Burst 4 Transfer Size

**EXAMPLES OF POSSIBLE CASES**

**Single service, Demand Mode, Single Transfer Size**

The assertion of XDREQ is need for every unit transfer (Single service mode), the operation continues while the XDREQ is asserted(Demand mode), and one pair of Read and Write(Single transfer size) is performed.



**Figure 9-4. Single service, Demand Mode, Single Transfer Size**

**Single Service/Handshake Mode, Single Transfer Size**

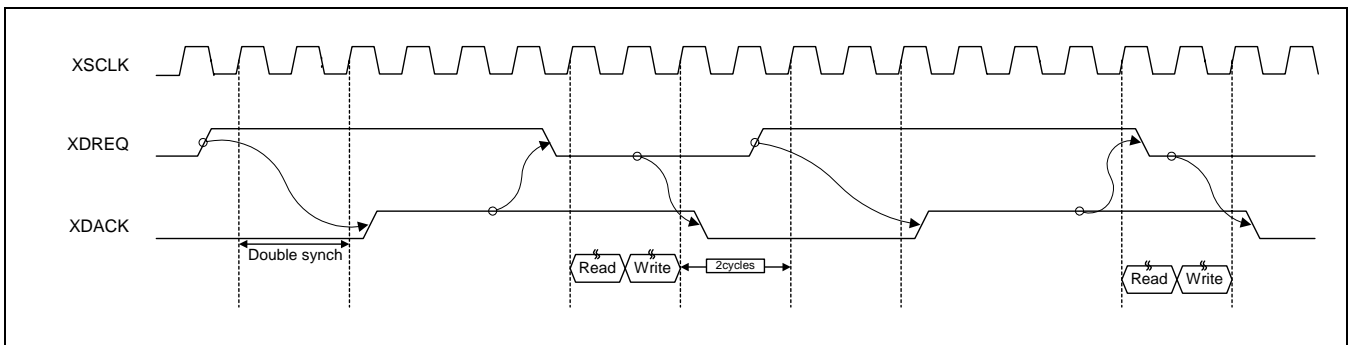

**Figure 9-5. Single service, Handshake Mode, Single Transfer Size**

**Whole service/Handshake Mode, Single Transfer Size**

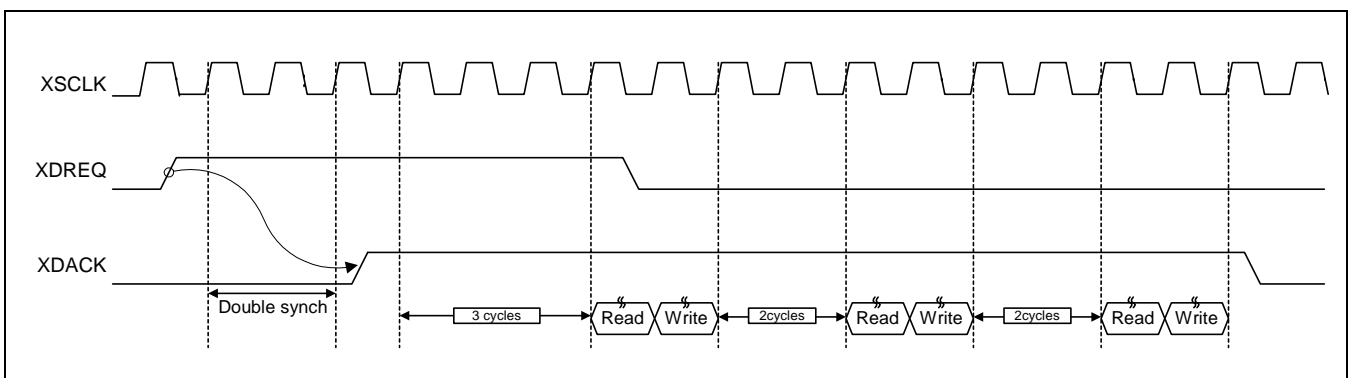

**Figure 9-6. Whole service, Handshake Mode, Single Transfer Size**

## DMA SPECIAL REGISTERS

There are seven control registers for each DMA channel. (Since there are four channels, the total number of control registers is 28.) Four of them are to control the DMA transfer, and other three are to see the status of DMA controller. The details of those registers are as follows.

### DMA INITIAL SOURCE REGISTER (DISRC)

Register	Address	R/W	Description	Reset Value
DISRC0	0x40400000	R/W	DMA0 initial source register	0x00000000
DISRC1	0x40500000	R/W	DMA1 initial source register	0x00000000
DISRC2	0x40600000	R/W	DMA2 initial source register	0x00000000
DISRC3	0x40700000	R/W	DMA3 initial source register	0x00000000

DISRCn	Bit	Description	Initial State
S_ADDR	[30:0]	These bits are the base address (start address) of source data to transfer. This value will be loaded into CURR_SRC only if the CURR_SRC is 0 and the DMA ACK is 1.	0x00000000

### DMA INITIAL SOURCE CONTROL REGISTER (DISRCC)

Register	Address	R/W	Description	Reset Value
DISRCC0	0x40400004	R/W	DMA0 initial source control register	0x00000000
DISRCC1	0x40500004	R/W	DMA1 initial source control register	0x00000000
DISRCC2	0x40600004	R/W	DMA2 initial source control register	0x00000000
DISRCC3	0x40700004	R/W	DMA3 initial source control register	0x00000000

DISRCn	Bit	Description	Initial State
LOC	[1]	Bit 1 is used to select the location of source. 0 = The source is in the system bus (AHB), 1 = The source is in the peripheral bus (APB)	0
INC	[0]	Bit 0 is used to select the address increment. 0 = Increment                      1 = Fixed  If it is 0, the address is increased by its data size after each transfer in burst and single transfer mode.  If it is 1, the address is not changed after the transfer (In the burst mode, address is increased during the burst transfer, but the address is recovered to its first value after the transfer).	0

**DMA INITIAL DESTINATION REGISTER (DIDST)**

Register	Address	R/W	Description	Reset Value
DIDST0	0x40400008	R/W	DMA0 initial destination register	0x00000000
DIDST1	0x40500008	R/W	DMA1 initial destination register	0x00000000
DIDST2	0x40600008	R/W	DMA2 initial destination register	0x00000000
DIDST3	0x40700008	R/W	DMA3 initial destination register	0x00000000

DIDSTn	Bit	Description	Initial State
D_ADDR	[30:0]	These bits are the base address (start address) of destination for the transfer. This value will be loaded into CURR_SRC only if the CURR_SRC is 0 and the DMA ACK is 1.	0x00000000

**DMA INITIAL DESTINATION CONTROL REGISTER (DIDSTC)**

Register	Address	R/W	Description	Reset Value
DIDSTC0	0x4040000C	R/W	DMA0 initial destination control register	0x00000000
DIDSTC1	0x4050000C	R/W	DMA1 initial destination control register	0x00000000
DIDSTC2	0x4060000C	R/W	DMA2 initial destination control register	0x00000000
DIDSTC3	0x4070000C	R/W	DMA3 initial destination control register	0x00000000

DIDSTn	Bit	Description	Initial State
CHK_INT	[2]	Select interrupt occurrence time when auto reload is setting 0 = Interrupt will occur when TC reaches 0 1 = Interrupt will occur after auto reload is performed.	0
LOC	[1]	Bit 1 is used to select the location of destination. 0 = The destination is in the system bus (AHB). 1 = The destination is in the peripheral bus (APB).	0
INC	[0]	Bit 0 is used to select the address increment. 0 = Increment                    1= Fixed If it is 0, the address is increased by its data size after each transfer in burst and single transfer mode. If it is 1, the address is not changed after the transfer (In the burst mode, address is increased during the burst transfer, but the address is recovered to its first value after the transfer).	0

## DMA CONTROL REGISTER (DCON)

Register	Address	R/W	Description	Reset Value
DCON0	0x40400010	R/W	DMA0 control register	0x00000000
DCON1	0x40500010	R/W	DMA1 control register	0x00000000
DCON2	0x40600010	R/W	DMA2 control register	0x00000000
DCON3	0x40700010	R/W	DMA3 control register	0x00000000

DCONn	Bit	Description	Initial State
DMD_HS	[31]	Select one between demand mode and handshake mode. 0 = Demand mode is selected 1 = Handshake mode is selected.  In both modes, DMA controller starts its transfer and asserts DACK for a given asserted DREQ. The difference between two modes is whether it waits for the de-asserted DACK or not. In handshake mode, DMA controller waits for the de-asserted DREQ before starting a new transfer. If it sees the de-asserted DREQ, it de-asserts DACK and waits for another asserted DREQ. In contrast, in the demand mode, DMA controller does not wait until the DREQ is de-asserted. It just de-asserts DACK and then starts another transfer if DREQ is asserted. We recommend using handshake mode for external DMA request sources to prevent unintended starts of new transfers.	0
SYNC	[30]	Select DREQ/DACK synchronization. 0 = DREQ and DACK are synchronized to PCLK (APB clock). 1 = DREQ and DACK are synchronized to HCLK (AHB clock).  Therefore, devices attached to AHB system bus, this bit has to be set to 1, while those attached to APB system, it should be set to 0. For the devices attached to external system, user should select this bit depending on whether the external system is synchronized with AHB system or APB system.	0
INT	[29]	Enable/Disable the interrupt setting for CURR_TC (terminal count) 0 = CURR_TC interrupt is disabled. user has to look the transfer count in the status register. (i.e., polling) 1 = Interrupt request is generated when all the transfer is done (i.e., CURR_TC becomes 0).	0
TSZ	[28]	Select the transfer size of an atomic transfer (i.e., transfer performed at each time DMA owns the bus before releasing the bus). 0 = A unit transfer is performed. 1 = A burst transfer of length four is performed.	0

DConN	Bit	Description	Initial State																																													
SERVMODE	[27]	Select the service mode between single service mode and whole service mode. 0 = Single service mode is selected in which after each atomic transfer (single or burst of length four) DMA stops and waits for another DMA request. 1 = Whole service mode is selected in which one request gets atomic transfers to be repeated until the transfer count reaches to 0. In this mode, additional request is not required. Here, note that even in the whole service mode, DMA releases the bus after each atomic transfer and then tries to re-get the bus to prevent starving of other bus masters.	0																																													
HWSRCSEL	[26:24]	Select DMA request source for each DMA. <table border="1" data-bbox="432 689 1390 1048"> <thead> <tr> <th></th> <th>Source0</th> <th>Source1</th> <th>Source2</th> <th>Source3</th> <th>Source4</th> <th>Source5</th> <th>Source6</th> <th>Source7</th> </tr> </thead> <tbody> <tr> <td>Ch-0</td> <td>nXDREQ0</td> <td>UART0</td> <td>I2SSDI</td> <td>PWM Timer</td> <td>USB device EP1</td> <td>AC97_PCMout</td> <td>MSTICK</td> <td>IrDA</td> </tr> <tr> <td>Ch-1</td> <td>nXDREQ1</td> <td>UART1</td> <td>I2SSDO</td> <td>SPI0</td> <td>USB device EP2</td> <td>AC97_PCMIn</td> <td>AC97_PCMout</td> <td>IrDA</td> </tr> <tr> <td>Ch-2</td> <td>UART0</td> <td>I2SSDO</td> <td>SD MMC</td> <td>PWM Timer</td> <td>USB device EP3</td> <td>AC97_MICIn</td> <td>AC97_PCMIn</td> <td>Reserved</td> </tr> <tr> <td>Ch-3</td> <td>UART1</td> <td>SD MMC</td> <td>SPI1</td> <td>Timer</td> <td>USB device EP4</td> <td>MSTICK</td> <td>AC97_MICIn</td> <td>Reserved</td> </tr> </tbody> </table> <p>This bits control the 8-1 MUX to select the DMA request source of each DMA. These bits have meanings if and only if H/W request mode is selected by DCONn[23].</p>		Source0	Source1	Source2	Source3	Source4	Source5	Source6	Source7	Ch-0	nXDREQ0	UART0	I2SSDI	PWM Timer	USB device EP1	AC97_PCMout	MSTICK	IrDA	Ch-1	nXDREQ1	UART1	I2SSDO	SPI0	USB device EP2	AC97_PCMIn	AC97_PCMout	IrDA	Ch-2	UART0	I2SSDO	SD MMC	PWM Timer	USB device EP3	AC97_MICIn	AC97_PCMIn	Reserved	Ch-3	UART1	SD MMC	SPI1	Timer	USB device EP4	MSTICK	AC97_MICIn	Reserved	000
	Source0	Source1	Source2	Source3	Source4	Source5	Source6	Source7																																								
Ch-0	nXDREQ0	UART0	I2SSDI	PWM Timer	USB device EP1	AC97_PCMout	MSTICK	IrDA																																								
Ch-1	nXDREQ1	UART1	I2SSDO	SPI0	USB device EP2	AC97_PCMIn	AC97_PCMout	IrDA																																								
Ch-2	UART0	I2SSDO	SD MMC	PWM Timer	USB device EP3	AC97_MICIn	AC97_PCMIn	Reserved																																								
Ch-3	UART1	SD MMC	SPI1	Timer	USB device EP4	MSTICK	AC97_MICIn	Reserved																																								
SWHW_SEL	[23]	Select the DMA source between software (S/W request mode) and hardware (H/W request mode). 0 = S/W request mode is selected and DMA is triggered by setting SW_TRIG bit of DMASKTRIG control register. 1 = DMA source selected by bit[25:24] is used to trigger the DMA operation.	0																																													
RELOAD	[22]	Set the reload on/off option. 0 = Auto reload is performed when a current value of transfer count becomes 0 (i.e., all the required transfers are performed). 1 = DMA channel(DMA REQ) is turned off when a current value of transfer count becomes 0. The channel on/off bit(DMASKTRIGn[1]) is set to 0(DREQ off) to prevent unintended further start of new DMA operation	0																																													
DSZ	[21:20]	Data size to be transferred. 00 = Byte                      01 = Half word 10 = Word                      11 = Reserved	00																																													



DCONn	Bit	Description	Initial State
TC	[19:0]	Initial transfer count (or transfer beat). Note that the actual number of bytes that are transferred is computed by the following equation: $DSZ \times TSZ \times TC$ , where DSZ, TSZ, and TC represent data size (DCONn[21:20]), transfer size (DCONn[28]), and initial transfer count, respectively. This value will be loaded into CURR_TC only if the CURR_TC is 0 and the DMA ACK is 1.	00000

**DMA STATUS REGISTER (DSTAT)**

Register	Address	R/W	Description	Reset Value
DSTAT0	0x40400014	R	DMA0 count register	000000h
DSTAT1	0x40500014	R	DMA1 count register	000000h
DSTAT2	0x40600014	R	DMA2 count register	000000h
DSTAT3	0x40700014	R	DMA3 count register	000000h

DSTATn	Bit	Description	Initial State
STAT	[21:20]	Status of this DMA controller. 00 = It indicates that DMA controller is ready for another DMA request. 01 = It indicates that DMA controller is busy for transfers.	00b
CURR_TC	[19:0]	Current value of transfer count. Note that transfer count is initially set to the value of DCONn[19:0] register and decreased by one at the end of every atomic transfer.	00000h

**DMA CURRENT SOURCE REGISTER (DCSRC)**

Register	Address	R/W	Description	Reset Value
DCSRC0	0x40400018	R	DMA0 current source register	0x00000000
DCSRC1	0x40500018	R	DMA1 current source register	0x00000000
DCSRC2	0x40600018	R	DMA2 current source register	0x00000000
DCSRC3	0x40700018	R	DMA3 current source register	0x00000000

DCSRCn	Bit	Description	Initial State
CURR_SRC	[30:0]	Current source address for DMA <sub>n</sub> .	0x00000000

**CURRENT DESTINATION REGISTER (DCDST)**

Register	Address	R/W	Description	Reset Value
DCDST0	0x4040001c	R	DMA0 current destination register	0x00000000
DCDST1	0x4050001c	R	DMA1 current destination register	0x00000000
DCDST2	0x4060001c	R	DMA2 current destination register	0x00000000
DCDST3	0x4070001c	R	DMA3 current destination register	0x00000000

DCDSTn	Bit	Description	Initial State
CURR_DST	[30:0]	Current destination address for DMA <sub>n</sub> .	0x00000000



## DMA MASK TRIGGER REGISTER (DMASKTRIG)

Register	Address	R/W	Description	Reset Value
DMASKTRIG0	0x40400020	R/W	DMA0 mask trigger register	000
DMASKTRIG1	0x40500020	R/W	DMA1 mask trigger register	000
DMASKTRIG2	0x40600020	R/W	DMA2 mask trigger register	000
DMASKTRIG3	0x40700020	R/W	DMA3 mask trigger register	000

DMASKTRIGn	Bit	Description	Initial State
STOP	[2]	<p>Stop the DMA operation.</p> <p>1 = DMA stops as soon as the current atomic transfer ends. If there is no current running atomic transfer, DMA stops immediately. The CURR_TC, CURR_SRC, CURR_DST will be 0.</p> <p><b>Note:</b> Due to possible current atomic transfer, "stop" may take several cycles. The finish of "stopping" operation (i.e., actual stop time) can be detected by waiting until the channel on/off bit(DMASKTRIGn[1]) is set to off. This stop is "actual stop".</p>	0
ON_OFF	[1]	<p>DMA channel on/off bit.</p> <p>0 = DMA channel is turned off. (DMA request to this channel is ignored.)</p> <p>1 = DMA channel is turned on and the DMA request is handled. This bit is automatically set to off if we set the DCONn[22] bit to "no auto reload" and/or STOP bit of DMASKTRIGn to "stop". Note that when DCON[22] bit is "no auto reload", this bit becomes 0 when CURR_TC reaches 0. If the STOP bit is 1, this bit becomes 0 as soon as the current atomic transfer finishes.</p> <p><b>Note:</b> This bit should not be changed manually during DMA operations (i.e., this has to be changed only by using DCON[22] or STOP bit.)</p>	0
SW_TRIG	[0]	<p>Trigger the DMA channel in S/W request mode.</p> <p>1 = it requests a DMA operation to this controller.</p> <p>However, note that for this trigger to have effects S/W request mode has to be selected (DCONn[23]) and channel ON_OFF bit has to be set to 1 (channel on). When DMA operation starts, this bit is cleared automatically.</p>	0

**NOTE:** You can freely change the values of DISRC register, DIDST registers, and TC field of DCON register. Those changes take effect only after the finish of current transfer (i.e., when CURR\_TC becomes 0). On the other hand, any change made to other registers and/or fields takes immediate effect. Therefore, be careful in changing those registers and fields.

# 10

## RTC (REAL TIME CLOCK)

### OVERVIEW

The RTC (Real Time Clock) unit can be operated by the backup battery while the system power is off. The RTC can transmit 8-bit data to CPU as BCD (Binary Coded Decimal) values using the STRB/LDRB ARM operation. The data include second, minute, hour, date, day, month, and year. The RTC unit works with an external 32.768 kHz crystal and also can perform the alarm function.

### FEATURE

- BCD number: second, minute, hour, date, day, month, year
- Leap year generator
- Alarm function: alarm interrupt or wake-up from power down mode.
- Year 2000 problem is removed.
- Independent power pin (RTCVDD)
- Supports millisecond tick time interrupt for RTOS kernel time tick.



## REAL TIME CLOCK OPERATION

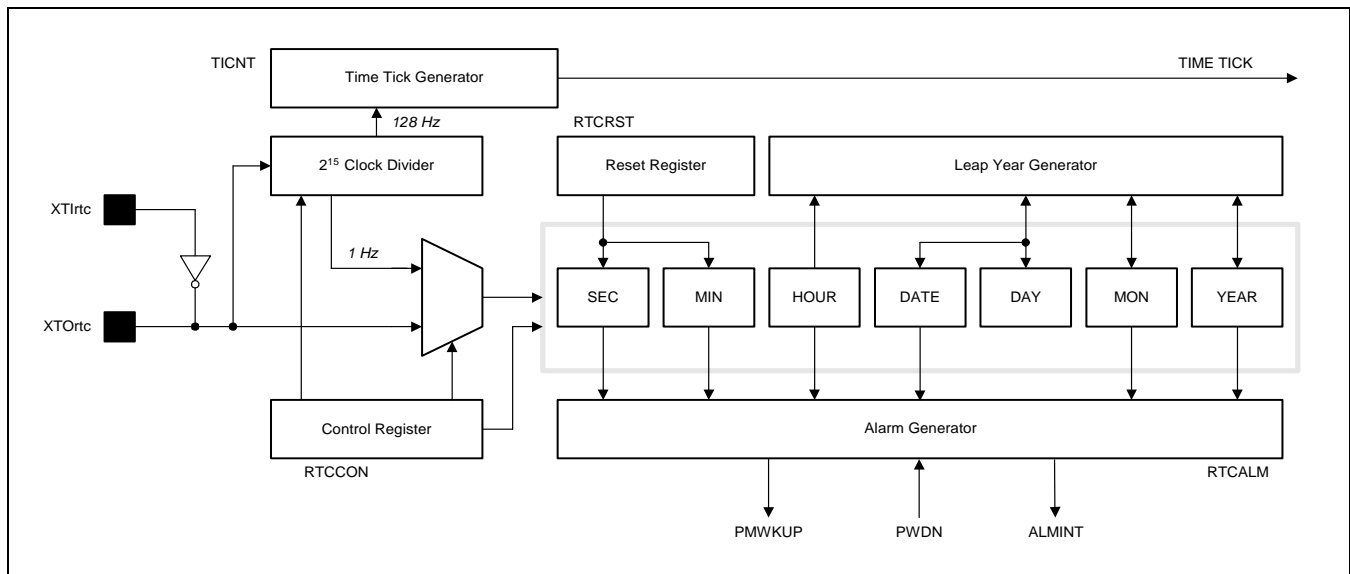

Figure 10-1. Real Time Clock Block Diagram

### LEAP YEAR GENERATOR

This block can determine whether the last date of each month is 28, 29, 30, or 31, based on data from BCDDATE, BCDMON, and BCDYEAR. This block considers the leap year in deciding on the last date. An 8-bit counter can only represent 2 BCD digits, so it cannot decide whether 00 year is a leap year or not. For example, it can not discriminate between 1900 and 2000. To solve this problem, the RTC block in S3C24A0A has hard-wired logic to support the leap year in 2000. Please note 1900 is not leap year while 2000 is leap year. Therefore, two digits of 00 in S3C24A0A denote 2000, not 1900.

### READ/WRITE REGISTERS

Bit 0 of the RTCCON register must be set to high in order to write the BCD register in RTC block. To display the sec., min., hour, date, month, and year, the CPU should read the data in BCDSEC, BCDMIN, BCDHOUR, BCDDAY, BCDDATE, BCDMON, and BCDYEAR registers, respectively, in the RTC block. However, a one second deviation may exist because multiple registers are read. For example, when the user reads the registers from BCDYEAR to BCDMIN, the result is assumed to be 2059(Year), 12(Month), 31(Date), 23(Hour) and 59(Minute). When the user read the BCDSEC register and the result is a value from 1 to 59(Second), there is no problem, but, if the result is 0 sec., the year, month, date, hour, and minute may be changed to 2060(Year), 1(Month), 1(Date), 0(Hour) and 0(Minute) because of the one second deviation that was mentioned. In this case, user should re-read from BCDYEAR to BCDSEC if BCDSEC is zero.

### BACKUP BATTERY OPERATION

The RTC logic can be driven by the backup battery, which supplies the power through the RTCVDD pin into RTC block, even if the system power is off. When the system off, the interfaces of the CPU and RTC logic should be blocked, and the backup battery only drives the oscillation circuit and the BCD counters to minimize power dissipation.

## ALARM FUNCTION

The RTC generates an alarm signal at a specified time in the power down mode or normal operation mode. In normal operation mode, the alarm interrupt (ALMINT) is activated. In the power down mode the power management wakeup (PMWKUP) signal is activated as well as the ALMINT. The RTC alarm register, RTCALM, determines the alarm enable/disable and the condition of the alarm time setting.

## TICK TIME INTERRUPT

The RTC tick time is used for interrupt request. The TICNT register has an interrupt enable bit and the count value for the interrupt. The count value reaches '0' when the tick time interrupt occurs. Then the period of interrupt is as follow:

$$\text{Period} = (n+1) / 128 \text{ second}$$

$n$  : Tick time count value (1~127)

This RTC time tick may be used for RTOS(real time operating system) kernel time tick. If time tick is generated by RTC time tick, the time related function of RTOS will always synchronized with real time.

## ROUND RESET FUNCTION

The round reset function can be performed by the RTC round reset register, RTCRST. The round boundary (30, 40, or 50 sec) of the second carry generation can be selected, and the second value is rounded to zero in the round reset. For example, when the current time is 23:37:47 and the round boundary is selected to 40 sec, the round reset changes the current time to 23:38:00.

### NOTE

All RTC registers have to be accessed by the byte unit using the STRB, LDRB instructions or char type pointer.

## 32.768KHZ X-TAL CONNECTION EXAMPLE

The Figure 10-2 is an example circuit of the RTC unit oscillation at 32.768kHz.

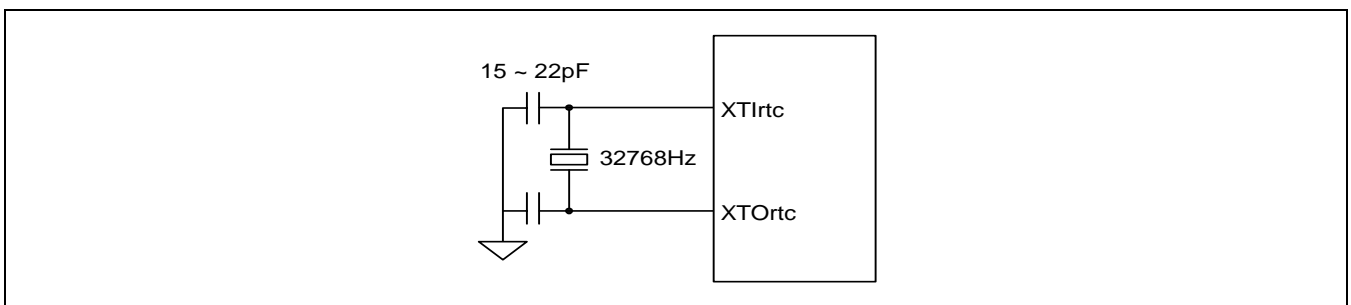

Figure 10-2. Main Oscillator Circuit Examples

## REAL TIME CLOCK SPECIAL REGISTERS

### REAL TIME CLOCK CONTROL REGISTER (RTCCON)

The RTCCON register consists of 4 bits such as the RTCEN, which controls the read/write enable of the BCD registers, CLKSEL, CNTSEL, and CLKRST for testing.

RTCEN bit can control all interfaces between the CPU and the RTC, so it should be set to 1 in an RTC control routine to enable data read/write after a system reset. Also before power off, the RTCEN bit should be cleared to 0 to prevent inadvertent writing into RTC registers.

Register	Address	R/W	Description	Reset Value
RTCCON	0x44200040	R/W (by byte)	RTC control register	0x0

RTCCON	Bit	Description	Initial State
CLKRST	[3]	RTC clock count reset 0 = No reset, 1 = Reset	0
CNTSEL	[2]	BCD count select 0 = Merge BCD counters 1 = Reserved (Separate BCD counters)	0
CLKSEL	[1]	BCD clock select 0 = XTAL 1/2 <sup>15</sup> divided clock 1 = Reserved (XTAL clock only for test)	0
RTCEN	[0]	RTC control enable 0 = Disable <b>Note:</b> Only BCD time count and read operation can be performed. 1 = Enable	0

**NOTE:** All RTC registers have to be accessed by byte unit using STRB and LDRB instructions or char type pointer.

### TICK TIME COUNT REGISTER (TICNT)

Register	Address	R/W	Description	Reset Value
TICNT	0x44200044	R/W (by byte)	Tick time count register	0x0

TICNT	Bit	Description	Initial State
TICK INT ENABLE	[7]	Tick time interrupt enable 0 = Disable 1 = Enable	0
TICK TIME COUNT	[6:0]	Tick time count value. (1~127) This counter value decreases internally, and users can not read this real counter value in working.	000000

**RTC ALARM CONTROL REGISTER (RTCALM)**

RTCALM register determines the alarm enable and the alarm time. Note that the RTCALM register generates the alarm signal through both ALMINT and PMWKUP in power down mode, but only through ALMINT in the normal operation mode.

Register	Address	R/W	Description	Reset Value
RTCALM	0x44200050	R/W (by byte)	RTC alarm control register	0x0

RTCALM	Bit	Description	Initial State
Reserved	[7]	Reserved	0
ALMEN	[6]	Alarm global enable 0 = Disable, 1 = Enable	0
YEAREN	[5]	Year alarm enable 0 = Disable, 1 = Enable	0
MONREN	[4]	Month alarm enable 0 = Disable, 1 = Enable	0
DATEEN	[3]	Date alarm enable 0 = Disable, 1 = Enable	0
HOUREN	[2]	Hour alarm enable 0 = Disable, 1 = Enable	0
MINEN	[1]	Minute alarm enable 0 = Disable, 1 = Enable	0
SECEN	[0]	Second alarm enable 0 = Disable, 1 = Enable	0





**ALARM SECOND DATA REGISTER (ALMSEC)**

Register	Address	R/W	Description	Reset Value
ALMSEC	0x44200054	R/W (by byte)	Alarm second data register	0x0

ALMSEC	Bit	Description	Initial State
Reserved	[7]	Reserved	0
SECDATA	[6:4]	BCD value for alarm second from 0 to 5	000
	[3:0]	from 0 to 9	0000

**ALARM MIN DATA REGISTER (ALMMIN)**

Register	Address	R/W	Description	Reset Value
ALMMIN	0x44200058	R/W (by byte)	Alarm minute data register	0x00

ALMMIN	Bit	Description	Initial State
Reserved	[7]	Reserved	0
MINDATA	[6:4]	BCD value for alarm minute from 0 to 5	000
	[3:0]	from 0 to 9	0000

**ALARM HOUR DATA REGISTER (ALMHOUR)**

Register	Address	R/W	Description	Reset Value
ALMHOUR	0x4420005C	R/W (by byte)	Alarm hour data register	0x0

ALMHOUR	Bit	Description	Initial State
Reserved	[7:6]	Reserved	00
HOURLDATA	[5:4]	BCD value for alarm hour from 0 to 2	00
	[3:0]	from 0 to 9	0000

**ALARM DATE DATA REGISTER (ALMDATE)**

Register	Address	R/W	Description	Reset Value
ALMDATE	0x44200060	R/W (by byte)	Alarm date data register	0x01

ALMDATE	Bit	Description	Initial State
Reserved	[7:6]	Reserved	00
DATEDATA	[5:4]	BCD value for alarm date, from 0 to 28, 29, 30, 31 from 0 to 3	00
	[3:0]	from 0 to 9	0001

**ALARM MON DATA REGISTER (ALMMON)**

Register	Address	R/W	Description	Reset Value
ALMMON	0x44200064	R/W (by byte)	Alarm month data register	0x01

ALMMON	Bit	Description	Initial State
Reserved	[7:5]	Reserved	00
MONDATA	[4]	BCD value for alarm month from 0 to 1	0
	[3:0]	from 0 to 9	0001

**ALARM YEAR DATA REGISTER (ALMYEAR)**

Register	Address	R/W	Description	Reset Value
ALMYEAR	0x44200068	R/W (by byte)	Alarm year data register	0x0

ALMYEAR	Bit	Description	Initial State
YEARDATA	[7:0]	BCD value for year from 00 to 99	0x0



**BCD SECOND REGISTER (BCDSEC)**

Register	Address	R/W	Description	Reset Value
BCDSEC	0x44200070	R/W (by byte)	BCD second register	Undefined

BCDSEC	Bit	Description	Initial State
SECDATA	[6:4]	BCD value for second from 0 to 5	–
	[3:0]	from 0 to 9	–

**BCD MINUTE REGISTER (BCDMIN)**

Register	Address	R/W	Description	Reset Value
BCDMIN	0x44200074	R/W (by byte)	BCD minute register	Undefined

BCDMIN	Bit	Description	Initial State
MINDATA	[6:4]	BCD value for minute from 0 to 5	–
	[3:0]	from 0 to 9	–

**BCD HOUR REGISTER (BCD HOUR)**

Register	Address	R/W	Description	Reset Value
BCD HOUR	0x44200078	R/W (by byte)	BCD hour register	Undefined

BCD HOUR	Bit	Description	Initial State
Reserved	[7:6]	Reserved	–
HOURDATA	[5:4]	BCD value for hour from 0 to 2	–
	[3:0]	from 0 to 9	–

**BCD DATE REGISTER (BCD DATE)**

Register	Address	R/W	Description	Reset Value
BCD DATE	0x4420007C	R/W (by byte)	BCD date register	Undefined

BCD DATE	Bit	Description	Initial State
Reserved	[7:6]	Reserved	–
DATEDATA	[5:4]	BCD value for date from 0 to 3	–
	[3:0]	from 0 to 9	–

**BCD DAY REGISTER (BCD DAY)**

Register	Address	R/W	Description	Reset Value
BCD DAY	0x44200080	R/W (by byte)	BCD day register	Undefined

BCD DAY	Bit	Description	Initial State
Reserved	[7:3]	Reserved	–
DAYDATA	[2:0]	BCD value for day from 1 to 7	–



**BCD MONTH REGISTER (BCDMON)**

Register	Address	R/W	Description	Reset Value
BCDMON	0x44200084	R/W (by byte)	BCD month register	Undefined

BCDMON	Bit	Description	Initial State
Reserved	[7:5]	Reserved	–
MONDATA	[4]	BCD value for month from 0 to 1	–
	[3:0]	from 0 to 9	–

**BCD YEAR REGISTER (BCDYEAR)**

Register	Address	R/W	Description	Reset Value
BCDYEAR	0x44200088	R/W (by byte)	BCD year register	Undefined

BCDYEAR	Bit	Description	Initial State
YEARDATA	[7:0]	BCD value for year from 00 to 99	–

# 11

## UART

### OVERVIEW

The S3C24A0A UART (Universal Asynchronous Receiver and Transmitter) unit provides two independent asynchronous serial I/O (SIO) ports, each of which can operate in interrupt-based or DMA-based mode. In other words, UART can generate an interrupt or DMA request to transfer data between CPU and UART. It can support bit rates of up to 115.2K bps, when UART use system clock. If external device provides UART with UCLK, then UART can operate at more higher speed. Each UART channel contains two 64-byte FIFOs for receiver and transmitter.

The S3C24A0A UART includes programmable baud-rates, infrared (IR) transmit/receive, one or two stop bit insertion, 5-bit, 6-bit, 7-bit or 8-bit data width and parity checking.

Each UART contains a baud-rate generator, transmitter, receiver and control unit, as shown in Figure11-1. The baud-rate generator can be clocked by PCLK. The transmitter and the receiver contain 64-byte FIFOs and data shifters. Data, which is to be transmitted, is written to FIFO and then copied to the transmit shifter. It is then shifted out by the transmit data pin (TxDn). The received data is shifted from the receive data pin (RxDn), and then copied to FIFO from the shifter.

### FEATURES

- RxD0, TxD0, RxD1, TxD1 with DMA-based or interrupt-based operation
- UART Ch 0, 1 with IrDA 1.0 & 64-byte FIFO
- UART Ch 0, 1 with nRTS0, nCTS0, nRTS1, nCTS1
- Supports handshake transmit / receive



**BLOCK DIAGRAM**

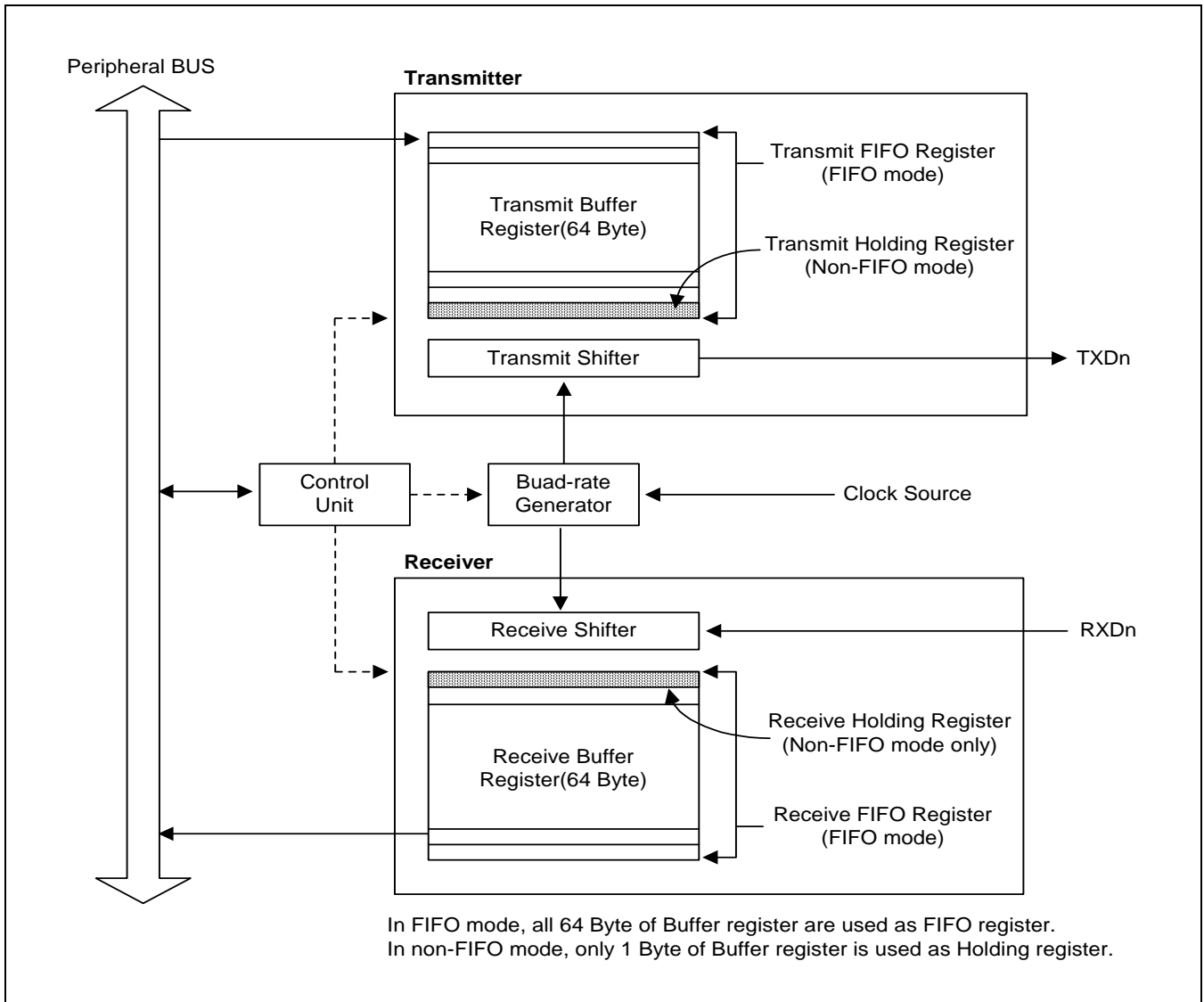

**Figure 11-1. UART Block Diagram (with FIFO)**

## UART OPERATION

The following sections will describe the UART operations that include data transmission, data reception, interrupt generation, baud-rate generation, loopback mode, infrared mode, and auto flow control.

### Data Transmission

The data frame for transmission is programmable. It consists of a start bit, 5 to 8 data bits, an optional parity bit and 1 to 2 stop bits, which can be specified by the line control register (ULCONn). The transmitter can also produce the break condition. The break condition forces the serial output to logic 0 state for one frame transmission time. This block transmits break signal after the present transmission word transmits perfectly. After the break signal transmission, it continuously transmits data into the Tx FIFO (Tx holding register in the case of Non-FIFO mode).

### Data Reception

Like the transmission, the data frame for reception is also programmable. It consists of a start bit, 5 to 8 data bits, an optional parity bit and 1 to 2 stop bits in the line control register (ULCONn). The receiver can detect overrun error. The overrun error indicates that new data has overwritten the old data before the old data has been read. Receive time-out condition occurs when it does not receive data during the 3 word time (This interval follows the setting of Word Length bit) and the Rx FIFO is not empty in the FIFO mode.

### Auto Flow Control(AFC)

S3C24A0A's UART 0 and UART 1 support auto flow control with nRTS and nCTS signals, in case, it would have to connect UART to UART. If users connect UART to a Modem, disable auto flow control bit in UMCOnn register and control the signal of nRTS by software.

In AFC, nRTS is controlled by condition of the receiver and operation of transmitter is controlled by the nCTS signal. The UART's transmitter transfers the data in FIFO only when nCTS signal active (In AFC, nCTS means that the other UART's FIFO is ready to receive data). Before the UART receives data, nRTS has to be activated when its receive FIFO has a spare more than 32-byte and has to be inactivated when its receive FIFO has a spare under 32-byte (In AFC, nRTS means that its own receive FIFO is ready to receive data).

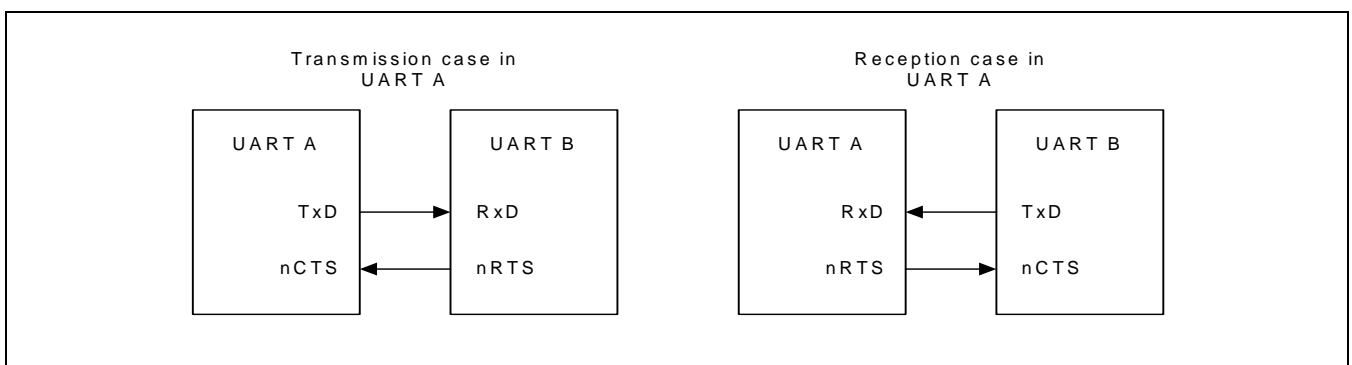

Figure 11-2. UART AFC Interface



**Non Auto-Flow control (Controlling nRTS and nCTS by S/W) Example****Rx operation with FIFO**

1. Select receive mode(Interrupt or DMA mode)
2. Check the value of Rx FIFO count in UFSTATn register. If the value is less than 32, users have to set the value of UMCONn[0] to '1'(activate nRTS), and if it is equal or larger than 32, users have to set the value to '0'(inactivate nRTS).
3. Repeat step 2.

**Tx operation with FIFO**

1. Select transmit mode (Interrupt or DMA mode)
2. Check the value of UMSTATn[0]. If the value is '1'(nCTS is activated), users write the data to Tx FIFO register.

### RS-232C Interface

If users connect to modem interface (not equal null modem), nRTS, nCTS, nDSR, nDTR, DCD and nRI signals are needed. In this case, users control these signals with general I/O ports by S/W because the AFC does not support the RS-232C interface.

### Interrupt/DMA Request Generation

Each UART of S3C24A0A has four status (Tx/Rx/Error) signals: Overrun error, Receive buffer data ready, Transmit buffer empty, and Transmit shifter empty, all of which are indicated by the corresponding UART status register (UTRSTATn/UERSTATn).

The overrun error can cause the receive error status interrupt request, if the receive-error-status-interrupt-enable bit is set to one in the control register, UCONn.

When the receiver transfers the data of the receive shifter to the receive FIFO register in FIFO mode and the number of received data reaches Rx FIFO Trigger Level, Rx interrupt is generated, if Receive mode in control register(UCONn) is selected as 1(Interrupt request or polling mode).

In the Non-FIFO mode, transferring the data of the receive shifter to the receiving holding register will cause Rx interrupt under the Interrupt request and polling mode.

When the transmitter transfers data from its transmit FIFO register to its transmit shifter and the number of data left in transmit FIFO reaches Tx FIFO Trigger Level, Tx interrupt is generated, if Transmit mode in control register is selected as Interrupt request or polling mode.

In the Non-FIFO mode, transferring data from the transmit holding register to the transmit shifter will cause Tx interrupt under the Interrupt request and polling mode.

If the Receive mode and Transmit mode in control register are selected as the DMA request mode then DMA request is occurred instead of Rx or Tx interrupt in the situation mentioned above.

**Table 11-1. Interrupts in Connection with FIFO**

Type	FIFO Mode	Non-FIFO Mode
Rx interrupt	Each time receive data reaches the trigger level of receive FIFO, the Rx interrupt will be generated. When the number of data in FIFO does not reaches Rx FIFO trigger Level and does not receive data during 3 word time(This interval follows the setting of Word Length bit), the Rx interrupt will be generated(receive time out).	Each time receive data becomes full, the receive holding register generates an interrupt.
Tx interrupt	Each time transmit data reaches the trigger level of transmit FIFO(Tx FIFO trigger Level), the Tx interrupt will be generated.	Each time transmit data become empty, the transmit holding register generates an interrupt.
Error interrupt	Overrun error will be generated, when it gets to the top of the receive FIFO without reading out data in it.	Overrun error generates an error interrupt immediately.



**UART Error Status FIFO**

UART has the error status FIFO besides the Rx FIFO register. The error status FIFO indicates which data, among FIFO registers, is received with an error. The error interrupt will be issued only when the data, which has an error, is ready to read out. To clear the error status FIFO, the URXHn with an error and UERSTATn must be read out.

For example,

It is assumed that the UART Rx FIFO receives A, B, C, D, and E characters sequentially and the frame error occurs while receiving 'B', and the parity error occurs while receiving 'D'.

The actual UART receive error will not generate any error interrupt because the character, which was received with an error, has not been read yet. The error interrupt will occur when the character is read out.

Figure 11-3 shows the UART receiving the five characters including the two errors.

Time	Sequence Flow	Error Interrupt	Note
#0	When no character is read out	–	
#1	A, B, C, D, and E is received	–	
#2	After A is read out	The frame error (in B) interrupt occurs.	The 'B' has to be read out.
#3	After B is read out	–	
#4	After C is read out	The parity error (in D) interrupt occurs.	The 'D' has to be read out.
#5	After D is read out	–	
#6	After E is read out	–	

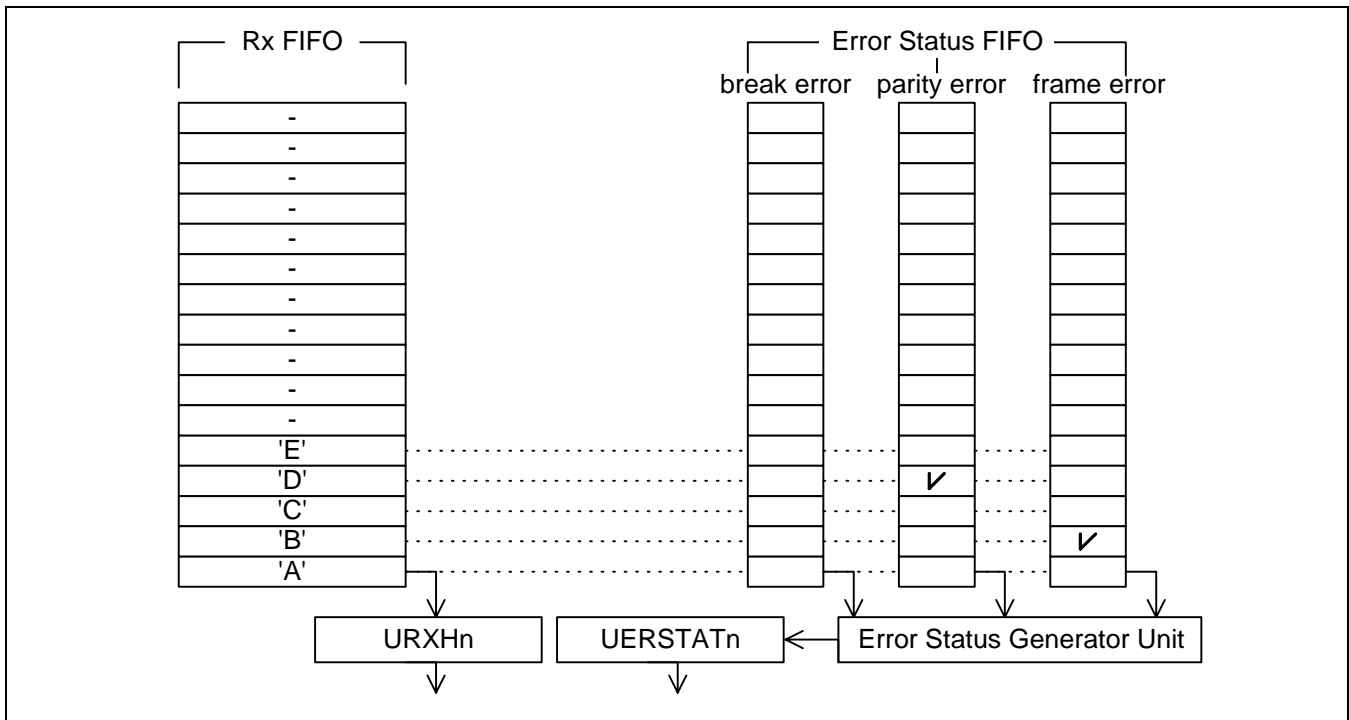

**Figure 11-3. Example showing UART Receiving 5 Characters with 2 Errors**

### Baud-Rate Generation

Each UART's baud-rate generator provides the serial clock for transmitter and receiver. The source clock for the baud-rate generator can be selected with the S3C24A0A's internal system clock or UCLK. In other words, dividend can be selected by the setting of Clock Selection of UCONn. The baud-rate clock is generated by dividing the source clock(PCLK or UCLK) by 16 and a 16-bit divisor specified in the UART baud-rate divisor register (UBRDIVn). The UBRDIVn can be determined as follows:

$$UBRDIVn = (int)(PCLK / (bps \times 16)) - 1$$

where the *UBRDIVn* should be from 1 to  $(2^{16}-1)$ .

For the accurate UART operation, S3C24A0A also supports UARTCLK as a dividend.

If UARTCLK, supplied by external UART device or system, is used, then serial clock of UART is exactly synchronized with UARTCLK. So, user can get the more precision UART operation. The UBRDIVn can be determined as follows:

$$UBRDIVn = (int)(UARTCLK / (bps \times 16)) - 1$$

where the *UBRDIVn* should be from 1 to  $(2^{16}-1)$  and UARTCLK should be smaller than PCLK.

For example, if the baud-rate is 115200 bps and PCLK or UARTCLK is 40 MHz, UBRDIVn is:

$$\begin{aligned} UBRDIVn &= (int)(40000000 / (115200 \times 16)) - 1 \\ &= (int)(21.7) - 1 \text{ [Round to the nearest whole number]} \\ &= 22 - 1 = 21 \end{aligned}$$

### Baud-Rate Error Tolerance

UART Frame error should be less than 1.87%(3/160).

$t_{UPCLK} = (UBRDIVn + 1) \times 16 \times 10 / PCLK$        $t_{UPCLK}$  : Real UART clock time

$t_{UEXACT} = 10 / \text{baud-rate}$        $t_{UEXACT}$  : Ideal UART clock time

UART error =  $(t_{UPCLK} - t_{UEXACT}) / t_{UEXACT} \times 100\%$

### NOTES

- 1Frame = 1start bit + 8 data bit + 1 stop bit.
2. In specific condition, we can support bit rates up to 921.6K bps. For example, when PCLK is 60MHz, you can use bit rates of 921.6K bps under UART error of 1.69%.

### Loop-back Mode

The S3C24A0A UART provides a test mode referred to as the loopback mode, to aid in isolating faults in the communication link. In this mode, the transmitted data is immediately received. This feature allows the processor to verify the internal transmit and to receive the data path of each SIO channel. This mode can be selected by setting the loopback-bit in the UART control register (UCONn).

### Break Condition

The break is defined as a continuous low level signal for one frame transmission time on the transmit data output.



**IR (Infrared) Mode**

The S3C24A0A UART block supports infrared (IR) transmission and reception, which can be selected by setting the infrared-mode bit in the UART line control register (ULCONn). The implementation of the mode is shown in Figure 11-4.

In IR transmit mode, the transmit period is pulsed at a rate of 3/16, the normal serial transmit rate (when the transmit data bit is zero); In IR receive mode, the receiver must detect the 3/16 pulsed period to recognize a zero value (refer to the frame timing diagrams shown in Figure 11-5, 11-6 and 11-7).

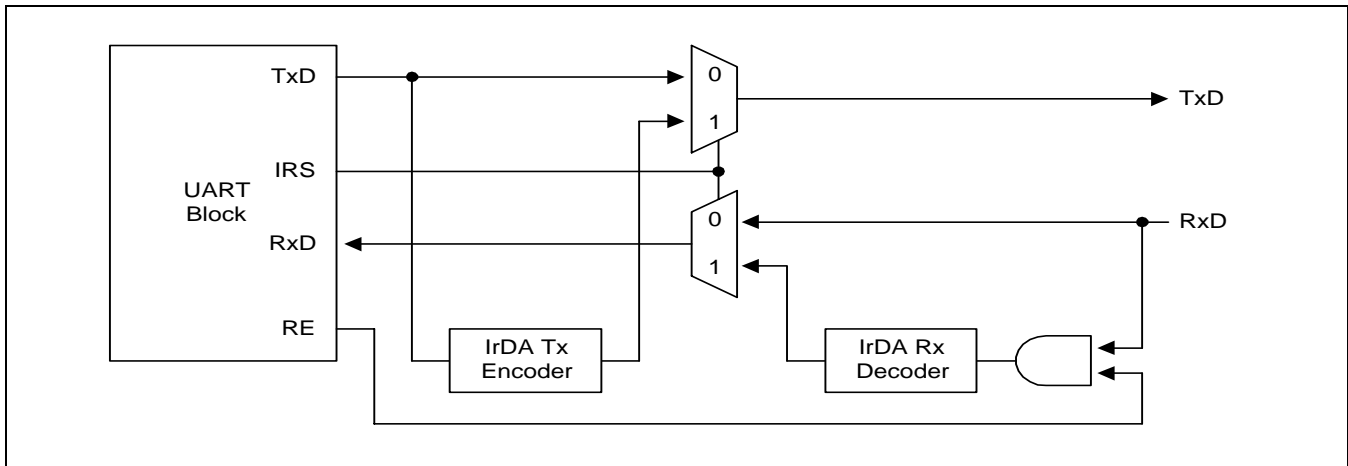

**Figure 11-4. IrDA Function Block Diagram**

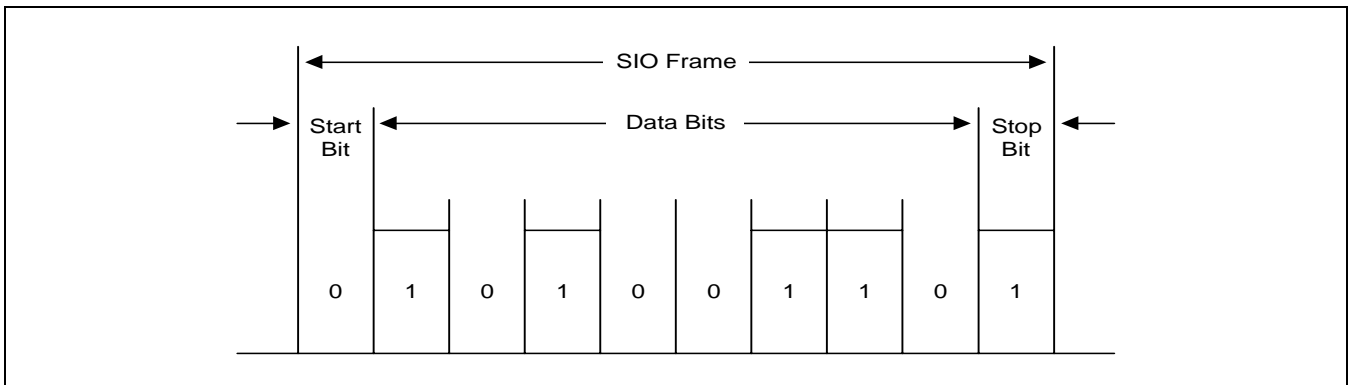

Figure 11-5. Serial I/O Frame Timing Diagram (Normal UART)

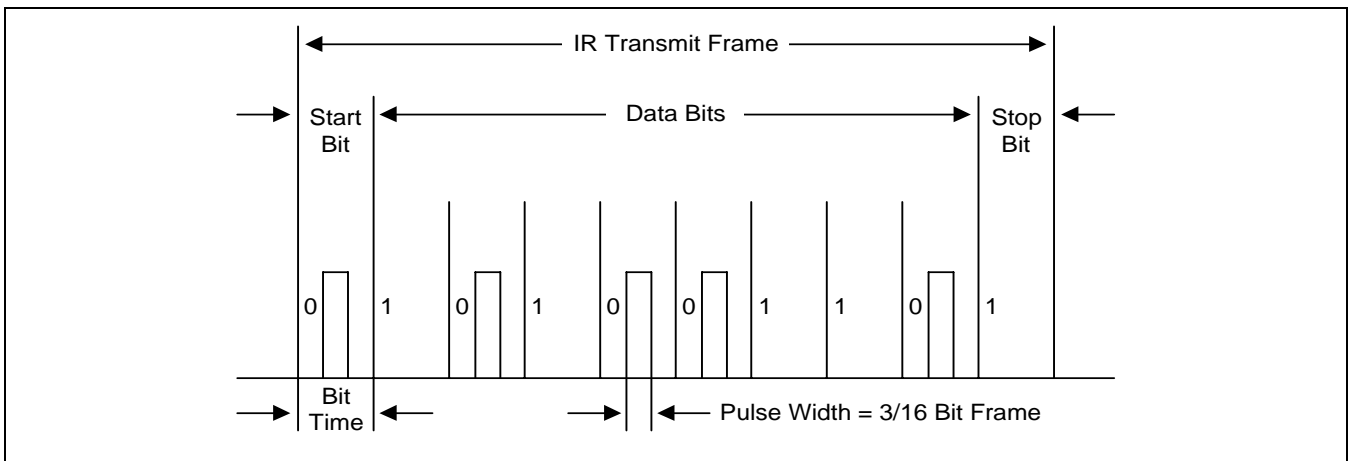

Figure 11-6. Infrared Transmit Mode Frame Timing Diagram

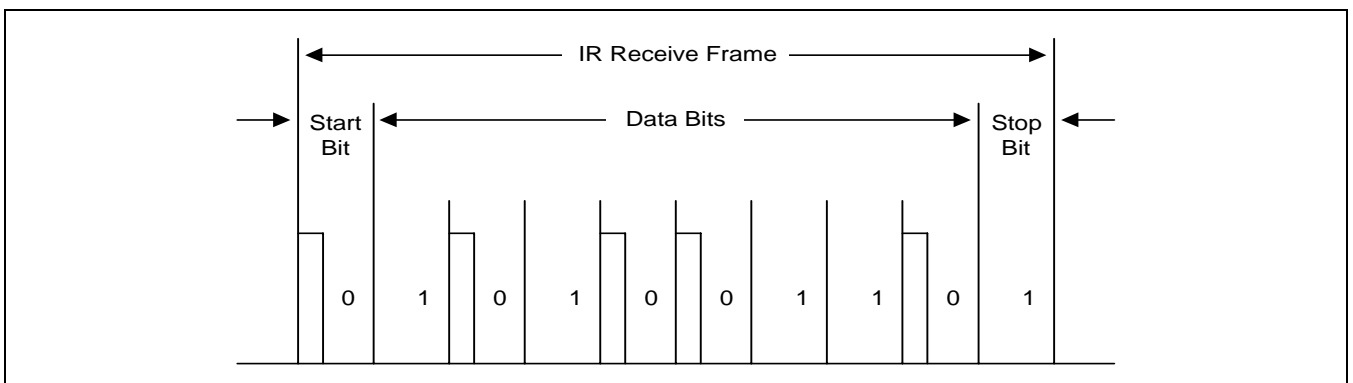

Figure 11-7. Infrared Receive Mode Frame Timing Diagram



## UART SPECIAL REGISTERS

### UART LINE CONTROL REGISTER

There are two UART line control registers, ULCON0 and ULCON1 in the UART block.

Register	Address	R/W	Description	Reset Value
ULCON0	0x44400000	R/W	UART channel 0 line control register	0x00
ULCON1	0x44404000	R/W	UART channel 1 line control register	0x00

ULCONn	Bit	Description	Initial State
Reserved	[7]	–	0
Infrared Mode	[6]	The Infrared mode determines whether or not to use the Infrared mode. 0 = Normal mode operation 1 = Infrared Tx/Rx mode	0
Parity Mode	[5:3]	The parity mode specifies how parity generation and checking are to be performed during UART transmit and receive operation. 0xx = No parity 100 = Odd parity 101 = Even parity 110 = Parity forced/checked as 1 111 = Parity forced/checked as 0	000
Number of stop bit	[2]	The number of stop bits specifies how many stop bits are to be used to signal end-of-frame. 0 = One stop bit per frame 1 = Two stop bit per frame	0
Word length	[1:0]	The word length indicates the number of data bits to be transmitted or received per frame. 00 = 5-bits    01 = 6-bits 10 = 7-bits    11 = 8-bits	00

## UART CONTROL REGISTER

There are two UART control registers, UCON0 and UCON1 in the UART block.

Register	Address	R/W	Description	Reset Value
UCON0	0x44400004	R/W	UART channel 0 control register	0x00
UCON1	0x44404004	R/W	UART channel 1 control register	0x00

UCONn	Bit	Description	Initial State
Clock selection	[10]	Select PCLK or UARTCLK for the UART baud rate. 0 = PCLK : $UBRDIVn = (int)(PCLK / (bps \times 16)) - 1$ 1 = UARTCLK : $UBRDIVn = (int)(UARTCLK / (bps \times 16)) - 1$	0
Tx interrupt type	[9]	Interrupt request type 0 = Pulse (Interrupt is requested as soon as the Tx buffer becomes empty in Non-FIFO mode or reaches Tx FIFO Trigger Level in FIFO mode) 1 = Level (Interrupt is requested while Tx buffer is empty in Non-FIFO mode or reaches Tx FIFO Trigger Level in FIFO mode)	0
Rx interrupt type	[8]	Interrupt request type 0 = Pulse (Interrupt is requested the instant Rx buffer receives the data in Non-FIFO mode or reaches Rx FIFO Trigger Level in FIFO mode) 1 = Level (Interrupt is requested while Rx buffer is receiving data in Non-FIFO mode or reaches Rx FIFO Trigger Level in FIFO mode)	0
Rx time out enable	[7]	Enable/Disable Rx time out interrupt when UART FIFO is enabled. The interrupt is a receive interrupt. 0 = Disable                      1 = Enable	0
Rx error status interrupt enable	[6]	This bit enables the UART to generate an interrupt if overrun error occurs during a receive operation. 0 = Do not generate receive error status interrupt 1 = Generate receive error status interrupt	0
Loop-back mode	[5]	Setting loop-back bit to 1 causes the UART to enter the loop-back mode. This mode is provided for test purposes only. 0 = Normal operation      1 = Loop-back mode	0
Send break signal	[4]	Setting this bit causes the UART to send a break during 1 frame time. This bit is auto-cleared after sending the break signal. 0 = Normal transmit      1 = Send break signal	0





## UART CONTROL REGISTER (Continued)

UCONn	Bit	Description	Initial State
Transmit mode	[3:2]	These two bits determine which function is currently able to write Tx data to the UART transmit buffer register. 00 = Disable 01 = Interrupt request or polling mode 10 = DMA0 or DMA2 request (Only for UART0), 11 = DMA1 or DMA3 request (Only for UART1)	00
Receive mode	[1:0]	These two bits determine which function is currently able to read data from UART receive buffer register. 00 = Disable 01 = Interrupt request or polling mode 10 = DMA0 or DMA2 request (Only for UART0), 11 = DMA1 or DMA3 request (Only for UART1)	00

**NOTE:** When the UART does not reach the FIFO trigger level and does not receive data during 3 word time in DMA receive mode with FIFO, the Rx interrupt will be generated (receive time out), and the users should check the FIFO status and read out the rest.

**UART FIFO CONTROL REGISTER**

There are two UART FIFO control registers, UFCON0 and UFCON1 in the UART block.

Register	Address	R/W	Description	Reset Value
UFCON0	0x44400008	R/W	UART channel 0 FIFO control register	0x0
UFCON1	0x44404008	R/W	UART channel 1 FIFO control register	0x0

UFCONn	Bit	Description	Initial State
Tx FIFO Trigger Level	[7:6]	These two bits determine the trigger level of transmit FIFO. 00 = Empty                      01 = 16-byte 10 = 32-byte                    11 = 48-byte	00
Rx FIFO Trigger Level	[5:4]	These two bits determine the trigger level of receive FIFO. 00 = 1-byte                      01 = 8-byte 10 = 16-byte                    11 = 32-byte	00
Reserved	[3]	Reserved	0
Tx FIFO Reset	[2]	This bit is auto-cleared after resetting FIFO 0 = Normal                      1 = Tx FIFO reset	0
Rx FIFO Reset	[1]	This bit is auto-cleared after resetting FIFO 0 = Normal                      1 = Rx FIFO reset	0
FIFO Enable	[0]	0 = FIFO disable              1 = FIFO mode	0

**NOTE:** When the UART does not reach the FIFO trigger level and does not receive data during 3 word time in DMA receive mode with FIFO, the Rx interrupt will be generated(receive time out), and the users should check the FIFO status and read out the rest.



**UART MODEM CONTROL REGISTER**

There are two UART MODEM control registers, UMCON0 and UMCON1, in the UART block.

Register	Address	R/W	Description	Reset Value
UMCON0	0x4440000C	R/W	UART channel 0 Modem control register	0x0
UMCON1	0x4440400C	R/W	UART channel 1 Modem control register	0x0

UMCONn	Bit	Description	Initial State
Reserved	[7:5]	These bits must be 0's	00
AFC(Auto Flow Control)	[4]	0 = Disable                      1 = Enable	0
Reserved	[3:1]	These bits must be 0's	00
Request to Send	[0]	If AFC bit is enabled, this value will be ignored. In this case the S3C24A0A will control nRTS automatically. If AFC bit is disabled, nRTS must be controlled by S/W. 0 = 'H' level (Inactivate nRTS) 1 = 'L' level (Activate nRTS)	0

**UART TX/RX STATUS REGISTER**

There are two UART Tx/Rx status registers, UTRSTAT0 and UTRSTAT1 in the UART block.

Register	Address	R/W	Description	Reset Value
UTRSTAT0	0x44400010	R	UART channel 0 Tx/Rx status register	0x6
UTRSTAT1	0x44404010	R	UART channel 1 Tx/Rx status register	0x6

UTRSTATn	Bit	Description	Initial State
Transmitter empty	[2]	This bit is automatically set to 1 when the transmit buffer register has no valid data to transmit and the transmit shift register is empty. 0 = Not empty 1 = Transmitter(transmit buffer & shifter register) empty	1
Transmit buffer empty	[1]	This bit is automatically set to 1 when transmit buffer register is empty. 0 =The buffer register is not empty 1 = Empty (In Non-FIFO mode, Interrupt or DMA is requested. In FIFO mode, Interrupt or DMA is requested, when Tx FIFO Trigger Level is set to 00(Empty)) If the UART uses the FIFO, users should check Tx FIFO Count bits and Tx FIFO Full bit in the UFSTAT register instead of this bit.	1
Receive buffer data ready	[0]	This bit is automatically set to 1 whenever receive buffer register contains valid data, received over the RXDn port. 0 = Empty 1 = The buffer register has a received data (In Non-FIFO mode, Interrupt or DMA is requested) If the UART uses the FIFO, users should check Rx FIFO Count bits and Rx FIFO Full bit in the UFSTAT register instead of this bit.	0



**UART ERROR STATUS REGISTER**

There are two UART Rx error status registers, UERSTAT0 and UERSTAT1 in the UART block.

Register	Address	R/W	Description	Reset Value
UERSTAT0	0x44400014	R	UART channel 0 Rx error status register	0x0
UERSTAT1	0x44404014	R	UART channel 1 Rx error status register	0x0

UERSTATn	Bit	Description	Initial State
Overrun Error	[0]	This bit is automatically set to 1 whenever an overrun error occurs during receive operation. 0 = No overrun error during receive 1 = Overrun error(Interrupt is requested)	0

**NOTE:** This bit is automatically cleared to 0 when the UART error status register is read.

**UART FIFO STATUS REGISTER**

There are two UART FIFO status registers, UFSTAT0 and UFSTAT1 in the UART block.

Register	Address	R/W	Description	Reset Value
UFSTAT0	0x44400018	R	UART channel 0 FIFO status register	0x0000
UFSTAT1	0x44404018	R	UART channel 1 FIFO status register	0x0000

UFSTATn	Bit	Description	Initial State
Reserved	[15]		0
Tx FIFO full	[14]	This bit is automatically set to 1 whenever transmit FIFO is full during transmit operation 0 = 0-byte ≤ Tx FIFO data ≤ 63-byte 1 = Full	0
Tx FIFO count	[13:8]	Number of data in Tx FIFO	0
Reserved	[7]		0
Rx FIFO full	[6]	This bit is automatically set to 1 whenever receive FIFO is full during receive operation 0 = 0-byte ≤ Rx FIFO data ≤ 63-byte 1 = Full	0
Rx FIFO count	[5:0]	Number of data in Rx FIFO	0



**UART MODEM STATUS REGISTER**

There are two UART modem status registers, UMSTAT0 and UMSTAT1 in the UART block.

Register	Address	R/W	Description	Reset Value
UMSTAT0	0x4440001C	R	UART channel 0 Modem status register	0x00
UMSTAT1	0x4440401C	R	UART channel 1 Modem status register	0x00

UMSTAT0	Bit	Description	Initial State
Reserved	[7:5]	–	0
DCTS	[4]	Delta CTS This bit indicates that the nCTS input to S3C24A0A has changed state since the last time it was read by CPU. (Refer to Figure 11-7) 0 = Has not changed 1 = Has changed	0
Reserved	[3:1]	–	0
Clear to send	[0]	0 = CTS signal is not activated (nCTS pin is high) 1 = CTS signal is activated (nCTS pin is low)	0

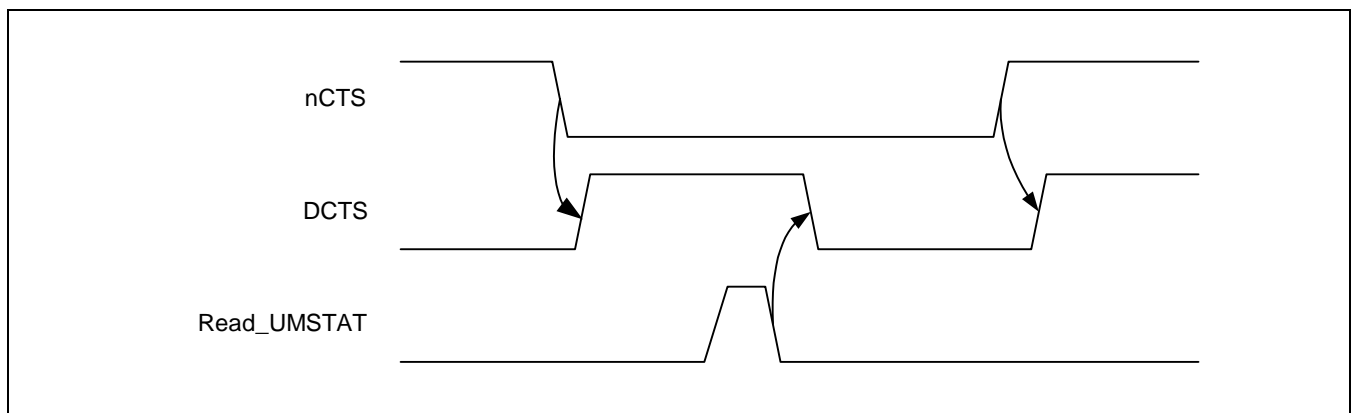

Figure 11-8. nCTS and Delta CTS Timing Diagram

**UART TRANSMIT BUFFER REGISTER(HOLDING REGISTER & FIFO REGISTER)**

There are two UART transmitting buffer registers, UTXH0 and UTXH1 in the UART block. UTXHn has an 8-bit data for transmission data.

Register	Address	R/W	Description	Reset Value
UTXH0	0x44400020	W (by byte)	UART channel 0 transmit buffer register	–
UTXH1	0x44404020	W (by byte)	UART channel 1 transmit buffer register	–

UTXHn	Bit	Description	Initial State
TXDATAn	[7:0]	Transmit data for UARTn	–

**UART RECEIVE BUFFER REGISTER (HOLDING REGISTER & FIFO REGISTER)**

There are two UART receive buffer registers, URXH0 and URXH1 in the UART block. URXHn has an 8-bit data for received data.

Register	Address	R/W	Description	Reset Value
URXH0	0x44400024	R (by byte)	UART channel 0 receive buffer register	–
URXH1	0x44404024	R (by byte)	UART channel 1 receive buffer register	–

URXHn	Bit	Description	Initial State
RXDATAn	[7:0]	Receive data for UARTn	–

**NOTE:** When an overrun error occurs, the URXHn must be read. If not, the next received data will also make an overrun error, even though the overrun bit of UERSTATn had been cleared.





**UART BAUD RATE DIVISOR REGISTER**

There are two UART baud rate divisor registers, UBRDIV0 and UBRDIV1 in the UART block. The value stored in the baud rate divisor register (UBRDIVn), is used to determine the serial Tx/Rx clock rate (baud rate) as follows:

$$\text{UBRDIVn} = (\text{int})(\text{PCLK} / (\text{bps} \times 16)) - 1$$

or

$$\text{UBRDIVn} = (\text{int})(\text{UARTCLK} / (\text{bps} \times 16)) - 1$$

where the UBRDIVn should be from 1 to ( $2^{16}-1$ ) and UARTCLK should be smaller than PCLK.

For example, if the baud-rate is 115200 bps and PCLK or UARTCLK is 40 MHz, UBRDIVn is:

$$\begin{aligned} \text{UBRDIVn} &= (\text{int})(40000000 / (115200 \times 16)) - 1 \\ &= (\text{int})(21.7) - 1 \text{ [Round to the nearest whole number]} \\ &= 22 - 1 = 21 \end{aligned}$$

Register	Address	R/W	Description	Reset Value
UBRDIV0	0x44400028	R/W	Baud rate divisor register 0	–
UBRDIV1	0x44404028	R/W	Baud rate divisor register 1	–

UBRDIVn	Bit	Description	Initial State
UBRDIV	[15:0]	Baud rate division value UBRDIVn >0(if UARTCLK is used, UBRDIVn>=0)	–

# 12

## IrDA CONTROLLER

### OVERVIEW

The Samsung IrDA Core is a wireless serial communication controller. Supporting two different types of IrDA speed (MIR, FIR), this core can transmit Ir(Infrared) pulses up to 4 Mbps speed. To lessen the CPU burden, it has configurable FIFO feature. This makes it easy to adjust the internal FIFO sizes.

A user can program the core by accessing 16 internal registers. When receiving the Ir pulses, this core detects three kinds of line errors such as CRC-error, PHY-error and payload length error.

### FEATURE

- IrDA specification compliant  
support IrDA 1.1 physical layer specification (4Mbps, 1.152Mbps and 0.576Mbps)
- Supports FIFO operation in the MIR and FIR mode
- Configurable FIFO size (16-byte or 64-byte)
- Supports Back-to-Back Transactions
- Supports software in selecting Temic-IBM or HP transceiver

**BLOCK DIAGRAM**

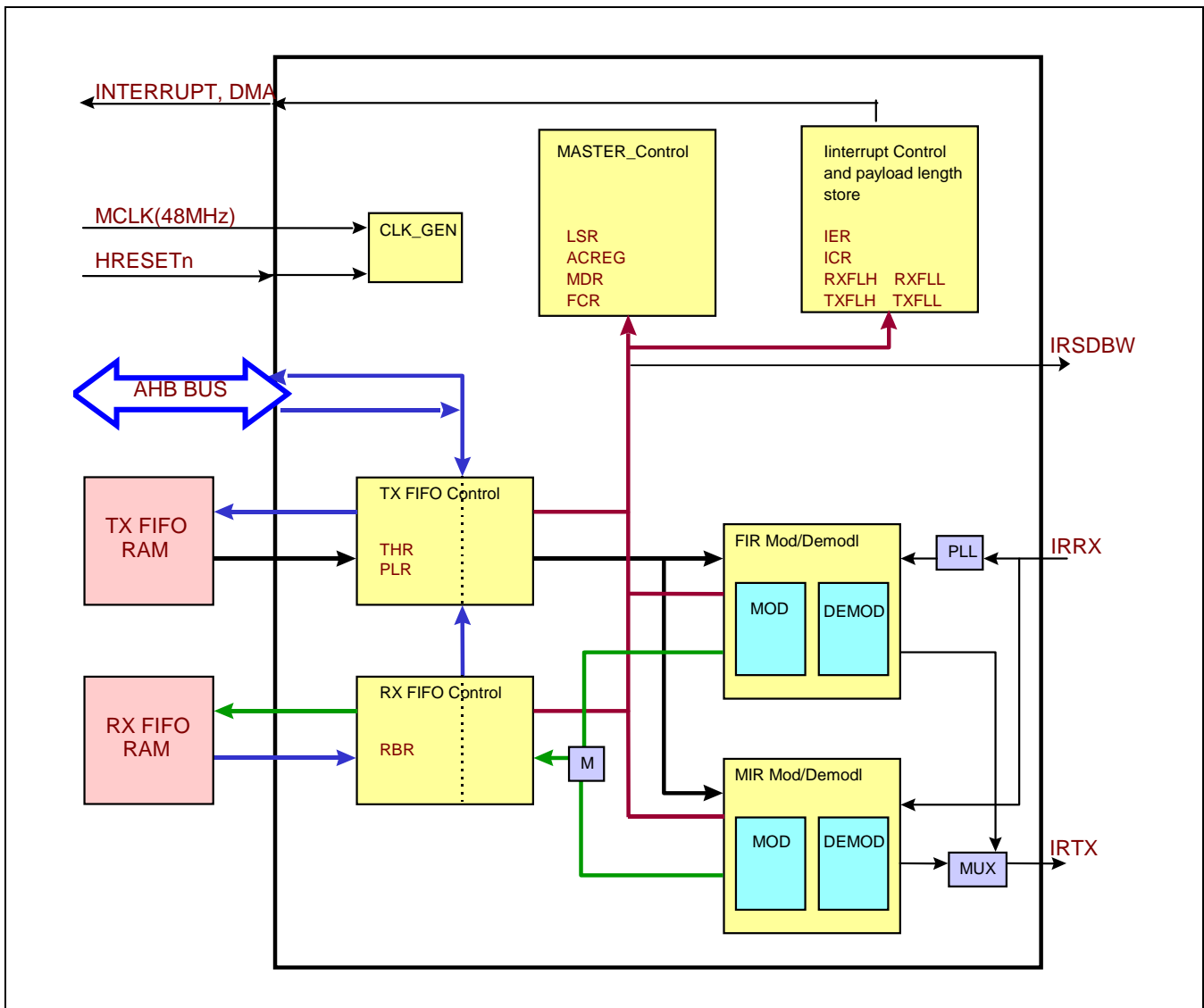

Figure 12-1. Block Diagram

**EXTERNAL INTERFACE SIGNALS**

- IrDA\_Tx : IrDA Tx signal (output)
- IrDA\_Rx : IrDA Rx signal (input)
- IrDA\_SDBW : IrDA Transceiver control (Shutdown, Bandwidth) (output)

## FUNCTION DESCRIPTION

### Fast-Speed Infrared (FIR) Mode (IrDA 1.1)

In this FIR mode, data communicates at the baud rate speed of 4 Mbps. In the data transmission mode, the core encodes the payload data into the 4PPM format and attaches the Preamble, Start Flag, CRC-32, and Stop flag on the encoded payload and shifts them out serially. In data receive mode, the core works in reverse direction. First, when Ir pulse is detected, the core recovers receiver clock from the incoming data and removes the Preamble and Start Flag, then it extracts the payload from the received 4PPM data until it meets the Stop Flag. The core detects three different kinds of errors which may occur in the middle of transmission. These are the Phy-Error, the Frame-Length Error and the CRC error. The last one, CRC error is checked when the entire payload data is received. The micro-controller can monitor the error status of the received frame by reading the Line Status Register (LSR) at the end of the frame receiving.

The following diagram shows the frame structure of the fir data frame. (The specific information of the each field can be found in IrDA specification.)

Preamble	Start Flag	Link Layer Frame(Payload)	CRC32	Stop Flag
----------	------------	---------------------------	-------	-----------

**Preamble** : 1000, 0000, 1010, 1000

**Start Flag** : 0000, 1100, 0000, 1100, 0110, 0000, 0110, 0000

**Stop Flag** : 0000, 1100, 0000, 1100, 0000, 0110, 0000, 0110

By programming the internal registers, the number of preambles can be selected from 4 to 32.

Data Bit Pair(DBP)	4PPM Data Symbol(DD)
00	1000
01	0100
10	0010
11	0001

**NOTE:** 4 PPM Coding

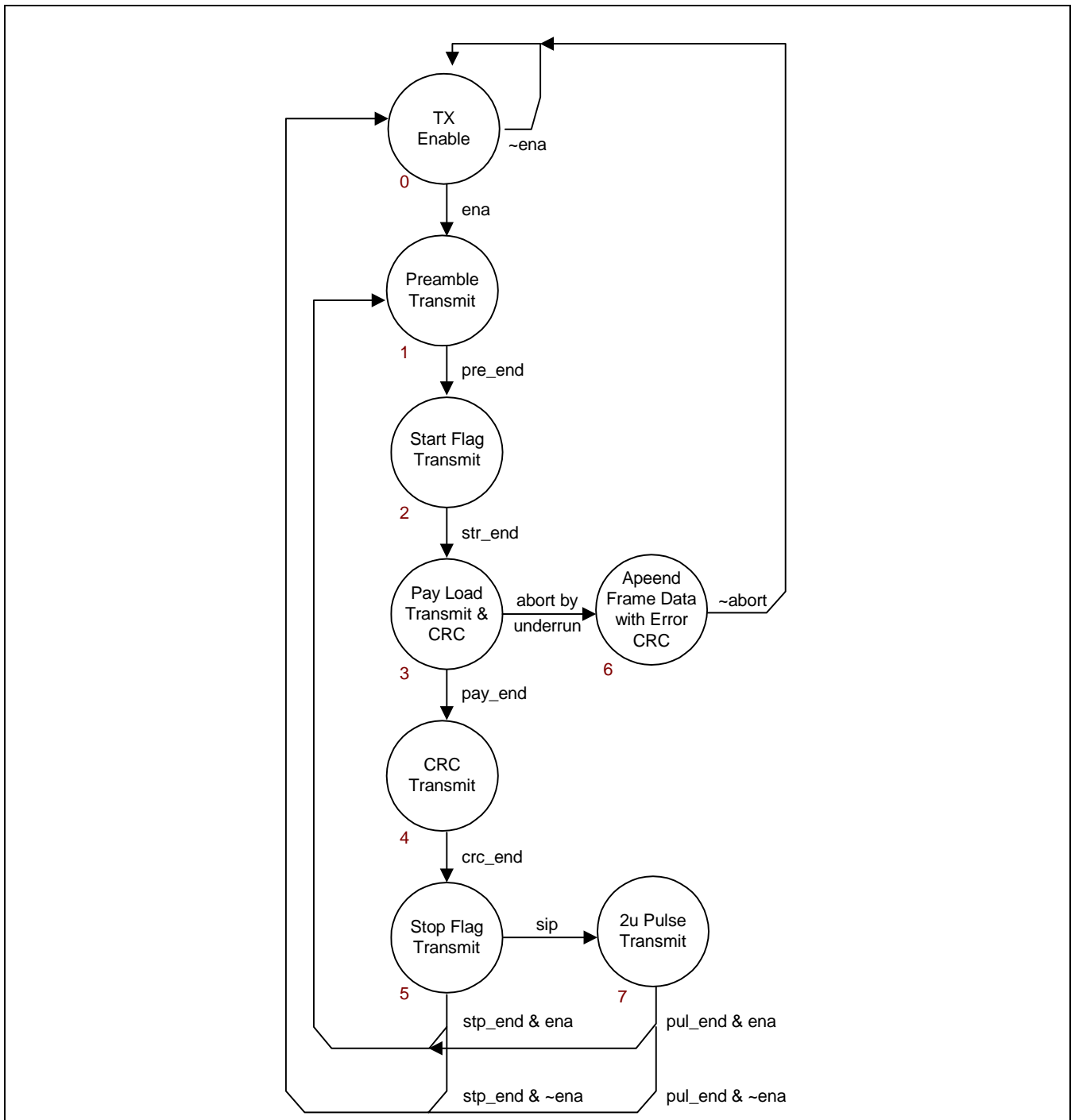

Figure 12-2. Fir Modulation Process

Figure 12-2 shows the FIR modulation state machine. The FIR transmission mode can be selected by programming ACR register. If an under-run condition occurs, the state machine appends the payload with error crc data and terminates the transmission.

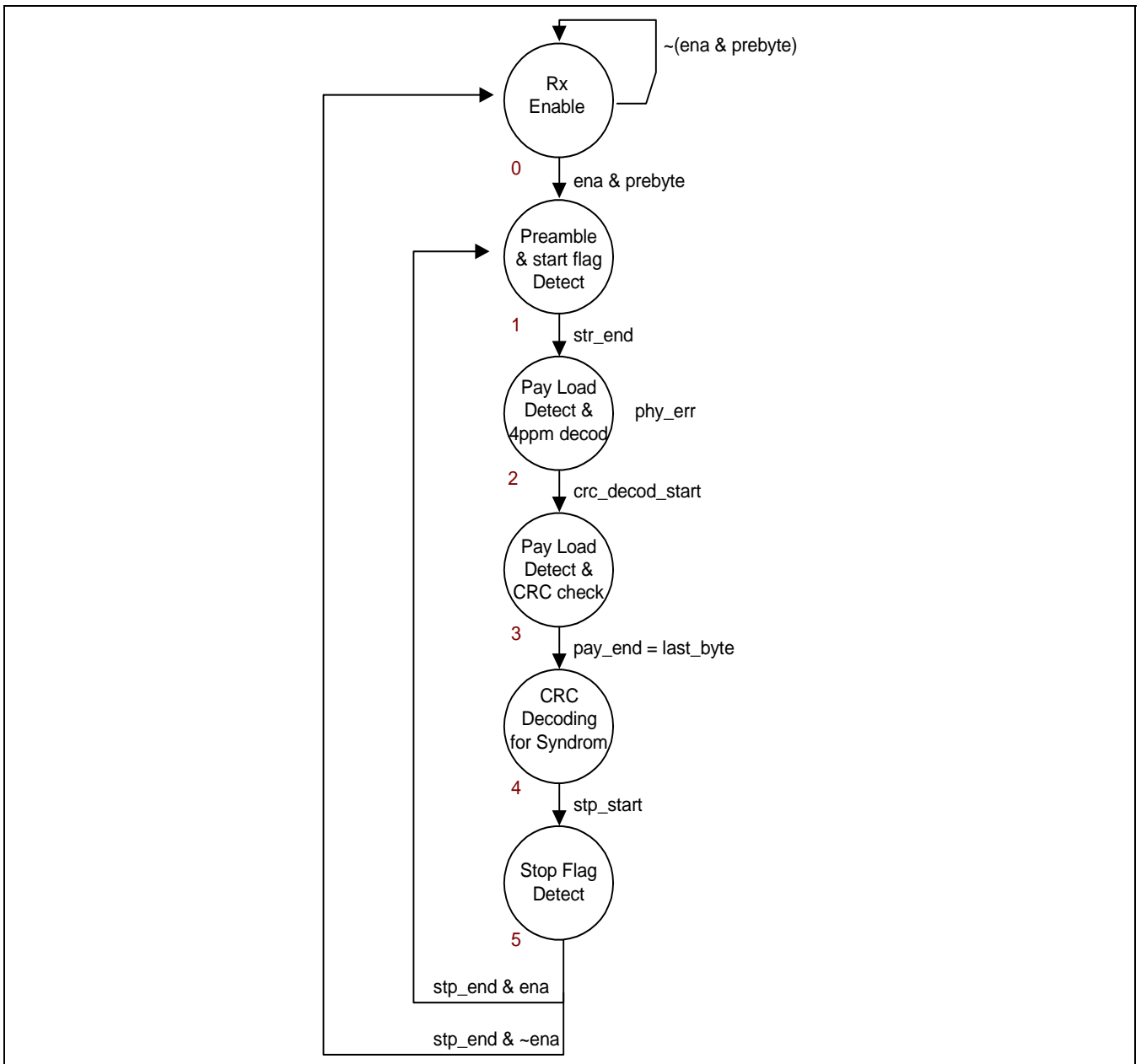

Figure 12-3. Fir Demodulation Process

Figure 12-3 shows FIR demodulation state machine. The state machine starts when ACR register bit 6 is set to logic high. The incoming data will be depacketized by removing preamble and start flag and stop flag .

Also, 4PPM decoding and CRC decoding is carried out.

### Medium-Speed Infrared (MIR) Mode (IrDA 1.1)

In MIR mode, data communicates at the speed of 1.152Mbps, and 0.576Mbps(half mode). The payload data is wrapped around by Start Flags, CRC-16, and Stop Flags. The Start Flag should be at least two bytes. Both in transmitting and receiving process, the basic wrapping and de-wrapping processes are same as the FIR mode, but, the MIR mode needs the bit-stuffing procedure. Bit stuffing in MIR mode have the core insert zero bit per every 5 consecutive ones in transmission mode. In receiving mode, the stuffed bit should be removed. Like the fir mode case, three different kind of errors (crc, phy and frame length error) can be reported to the microcontroller in receiving mode by reading the LSR register.

The diagram below shows the data structure of MIR frame.

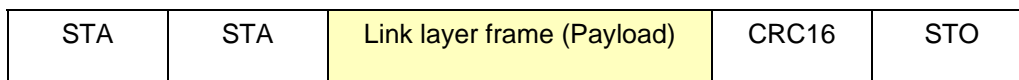

**STA** : Beginning flag, 01111110 binary  
**CRC16** : CCITT 16 bit CRC  
**STO** : Ending flag, 01111110 binary

The MIR pulse is modulated by 1/4 pulse format. The following diagram shows how the pulse is generated.

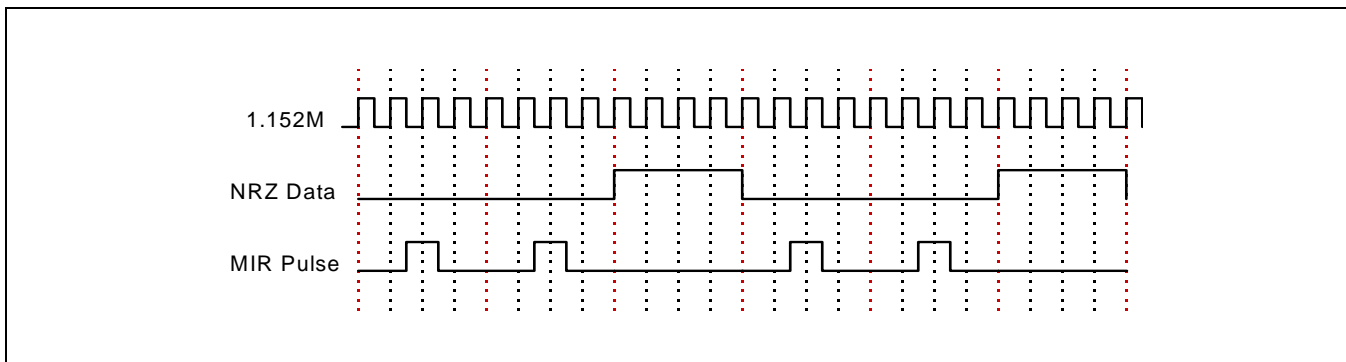

Figure 12-4. Pulse Modulation in MIR Mode

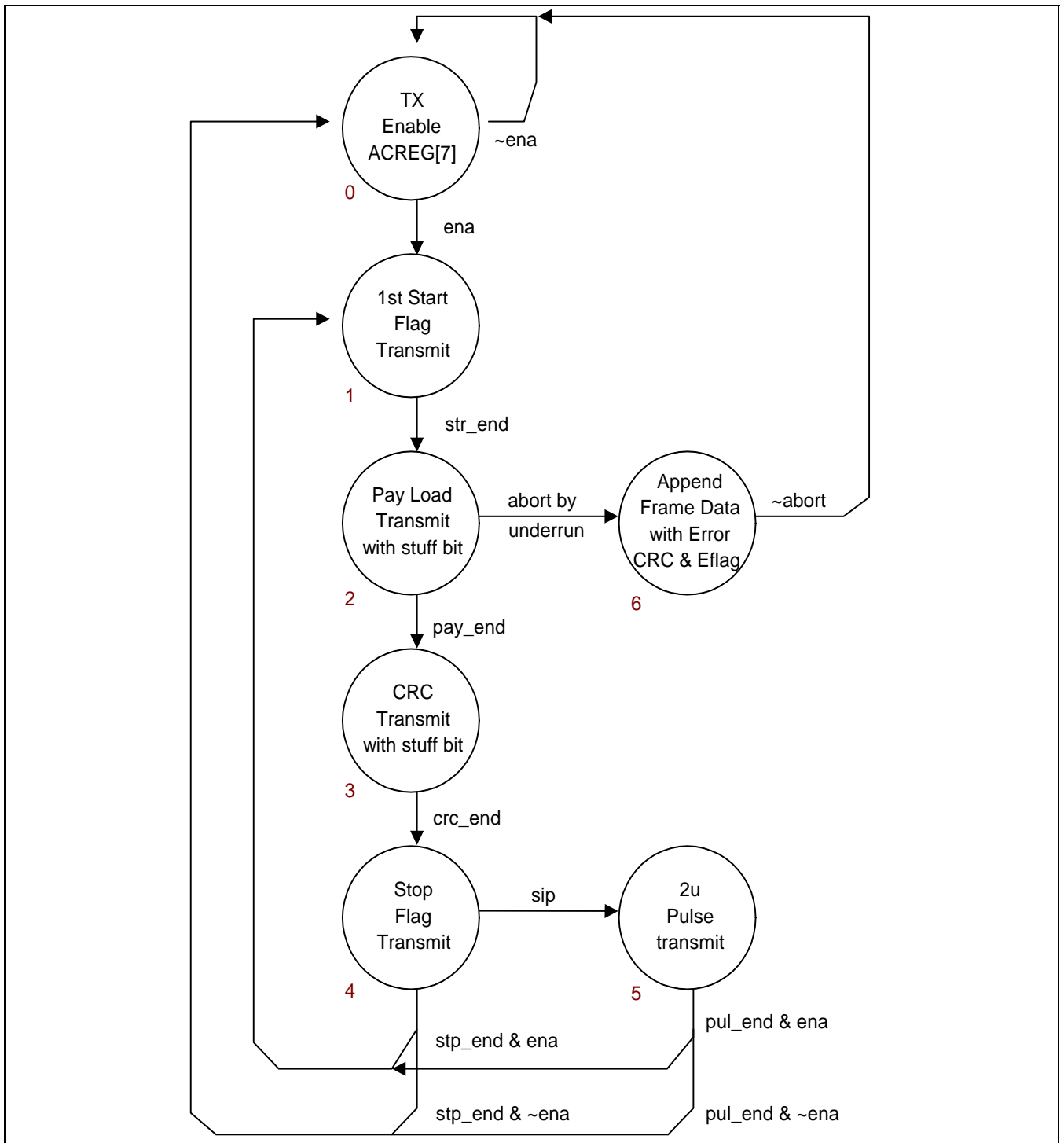
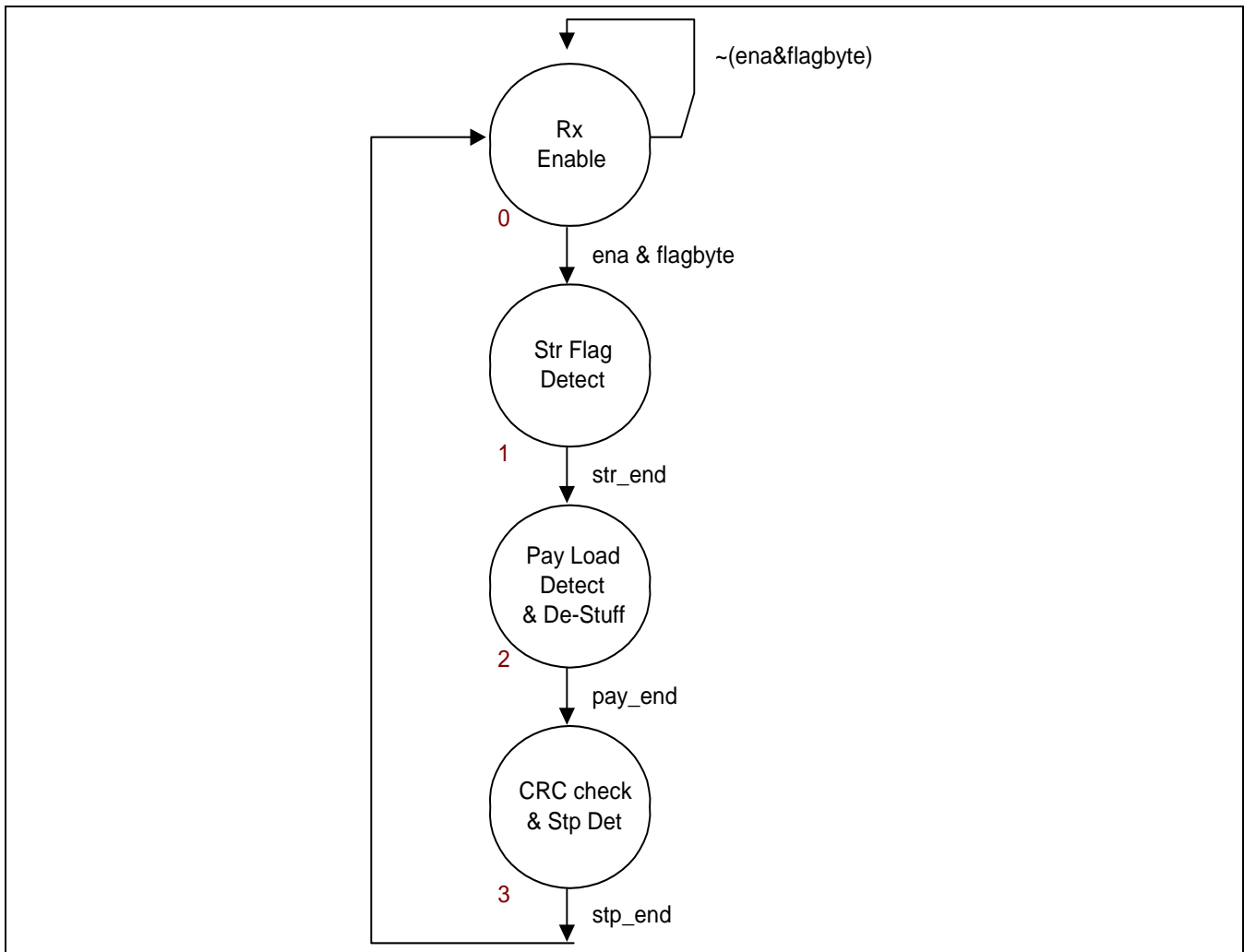

Figure 12-5. Mir Modulation Process

Figure 12-5 shows MIR modulation state machine. This machine works very similarly with FIR modulation state machine. The major difference is that the MIR data transmission needs bit stuffing. After the every 5 consecutive ones, a zero data should be stuffed in MIR payload data. The state machine for this bit-stuffing is not presented here.





**Figure 12-6. Mir Demodulation Process**

Figure 12-6 shows the MIR demodulation state machine. Basically, it has similar structure with FIR demodulation state machine. But, instead having 4 PPM demodulation phase, it has the stage of removing stuffed bits from payload data stream. Since the MIR data stream doesn't have preamble data, the preamble/start flag data detection stage in MIR demodulation is simplified to start flag detection state.

## CORE INITIALIZATION PROCEDURE

### MIR/FIR Mode Initialization Operation

1. Program the MDR register to select the MIR/FIR mode.
2. Program the ACR register to select the transceiver type.
  - For the Temic-IBM type transceiver, program twice in ACR[0] = 1'b0 and ACR[0] = 1'b1.
  - For the HP type transceiver, program just once in ACR[0] = 1'b0 to FIR/MIR mode.
3. Program the PLR register to select the number of preamble or start flag, and TX threshold level.
4. Program the RXFLL and RXFLH register (maximum available receive bytes in frame).
5. Program the TXFLL and TXFLH register (transmit bytes in transmission frame).
6. Program the FCR register (FIFO size and RX threshold level).
7. Program the IER register (the types of interrupt).
8. Program the ACR register (TX enable or RX enable).
9. Program the ICR register (interrupt enable).
10. Service Interrupt signal from the core.

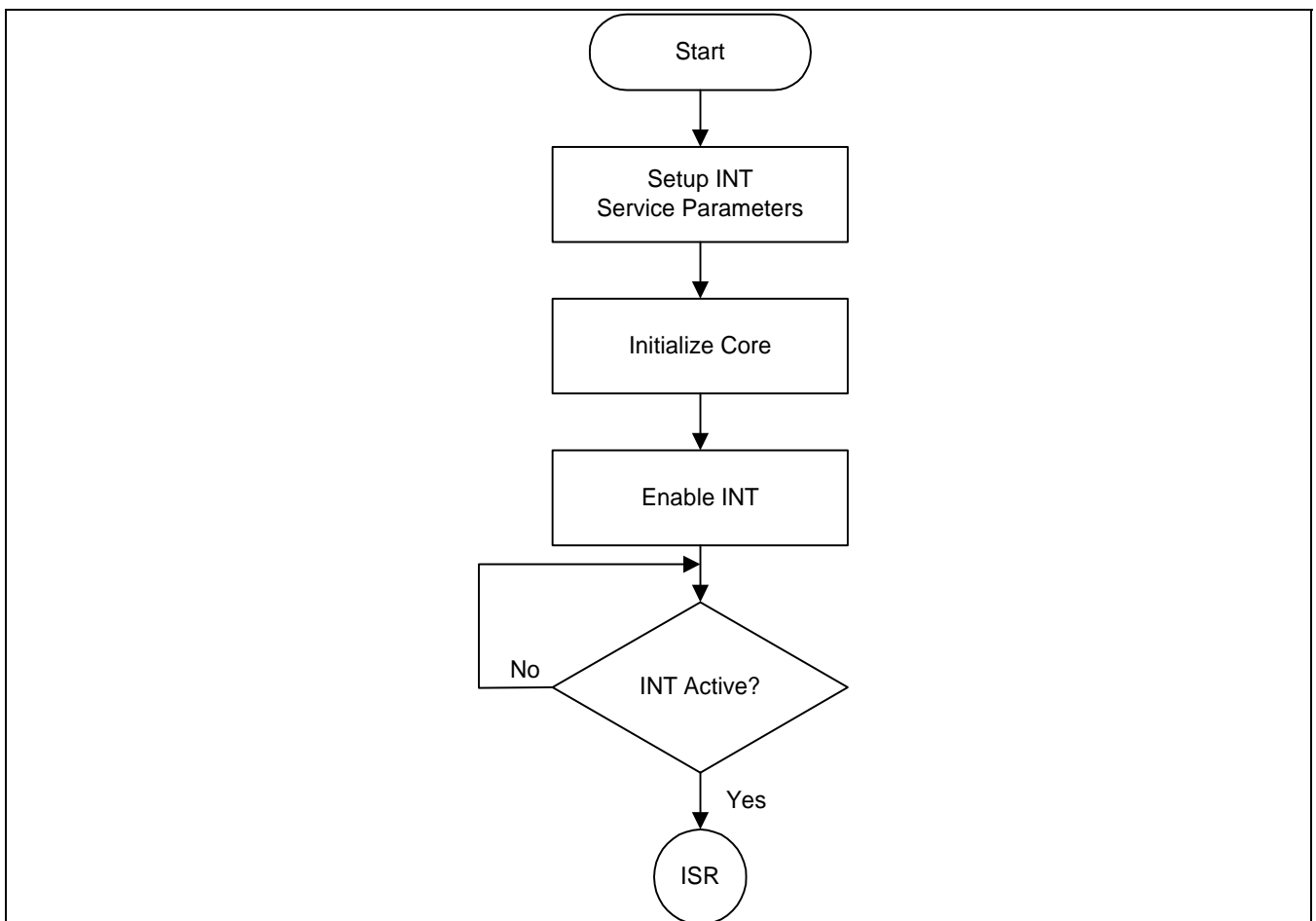

Figure 12-7. General Program Flowchart

## SPECIAL FUNCTION REGISTERS

### IrDA CONTROL REGISTER (IrDA\_CNT)

Register	Address	R/W	Description	Reset Value
IrDA_CNT	0x41800000	R/W	IrDA control register	0x00

IrDA_CNT	Bit	Description	Initial State
TX enable	[7]	TX enable. Bit 7 must be set to '1' to enable data transmission in MIR/FIR Ir modes.	0
RX enable	[6]	RX enable. Bit 6 must be set to '1' to enable data receive in all MIR/FIR Ir modes.	0
Core loop	[5]	Core loop for software debugging. The IRRX port connects directly to the IRTX internally.	0
MIR half mode	[4]	MIR half mode. When bit 4 is set to a '1', the operating speed in the MIR mode changes from 1.152 Mbps to 0.576 Mbps.	0
Send IR pulse	[3]	Send 1.6-us IR pulse. When the IrDA_MDR[3] bit equals to a '1' and the CPU writes a '1' to this bit, the transmitting interface device sends a 1.6-us IR pulse at the end of the frame. Bit 3 is cleared automatically by the transmitting interface device at the end of 1.6-us IR pulse data transmission.	0
Reserved	[2]	Reserved	0
Frame abort	[1]	Frame abort. The CPU can intentionally abort data transmission of a frame by writing a '1' to bit 1. Neither the end flag nor the CRC bits are appended to the frame. The receiver will find the frame with the abort pattern in the MIR mode and a PHY-error in the FIR mode. The CPU must reset the TX FIFO and reset this bit by writing a '0' to bit '1' before next frame can be transmitted.	0
SD/BW	[0]	This signal controls IrDA_SDBW output signal. It is used for controlling mode (shutdown, band width) of IrDA transceiver.	0

**IrDA MODE DEFINITION REGISTER(IrDA\_MDR)**

Register	Address	R/W	Description	Reset Value
IrDA_MDR	0x41800004	R/W	IrDA mode definition register	0x00

IrDA_MDR	Bit	Description	Initial State
Reserved	[7:5]	Reserved	0
SIP Select	[4]	SIP select method. If this bit is set to '1' and the IrDA_CNT[3] is set to '1', the SIP pulse is appended at the end of FIR/MIR TX frame. Likewise, when this bit is set to a '0', SIP is generated at the end of the every FIR/MIR frames. If IrDA_CNT[3] is set to '0', setting this bit to '1' doesn't help to generate SIP. Along with IrDA_CNT[3] bit, the way of SIP generation can be controlled.	0
Temic select	[3]	Bit 3 is Temic transceiver select bit. When bit 3 is clear to "0", core automatically selects in Temic transceiver mode.	0
Mode select	[2:0]	Bit 2, bit 1 and bit 0 select the mode of operation as 100 = FIR Mode 010 = MIR Mode	0

**IrDA INTERRUPT / DMA CONFIGURATION REGISTER (IrDA\_CNF)**

Register	Address	R/W	Description	Reset Value
IrDA_CNF	0x41800008	R/W	IrDA interrupt / DMA configuration register	0x00

IrDA_CNF	Bit	Description	Initial State
Reserved	[7:4]	Reserved	–
DMA Enable	[3]	1 = DMA enable	0
DMA Mode	[2]	0 = Tx DMA 1 = Rx DMA	0
Reserved	[1]	Reserved	–
Interrupt Enable	[0]	The bit 0 enables Interrupt output signal.	0

**IrDA INTERRUPT ENALBLE REGISTER (IrDA\_IER)**

Register	Address	R/W	Description	Reset Value
IrDA_IER	0x4180000C	R/W	IrDA interrupt enable register	0x00

IrDA_IER	Bit	Description	Initial State
Last byte to Rx FIFO	[7]	Enables state indication interrupt when Last byte write to RX FIFO.	0
Error indication	[6]	Enables error status indication interrupt in data receiving mode.	0
Tx Underrun	[5]	Enables transmitter under-run interrupt.	0
Last byte detect	[4]	Detect stop-flag interrupt enable. If this bit is set to "1", an interrupt signal will be activated when the last byte of the received data frame comes into the demodulation block and the CRC decoding is finished.	0
Rx overrun	[3]	Enables receiver over-run interrupt.	0
Last byte read from Rx FIFO	[2]	Bit 2 enables last byte from RX FIFO interrupt which is generated when the microcontroller reads the last byte of the frame from the RX FIFO.	0
Tx FIFO below threshold	[1]	Bit 1 enables an TX FIFO below threshold level interrupt when the available empty space in TX FIFO is over the threshold level.	0
Rx FIFO over threshold	[0]	Bit 0 enables received data in RX FIFO over threshold level interrupt when the RX FIFO is equal to or above the threshold level.	0

**IrDA INTERRUPT IDENTIFICATION REGISTER (IrDA\_IIR)**

Register	Address	R/W	Description	Reset Value
IrDA_IIR	0x41800010	R	IrDA interrupt identification register	0x00

IrDA_IIR	Bit	Description	Initial State
Last byte to Rx FIFO	[7]	Last byte write to RX FIFO interrupt pending. When the last payload byte of the frame is loaded into the RX FIFO, bit 7 is set to '1'. Bit 7 is set prior to bit 2. Bit 7 is cleared when it is read.	0
Error indication	[6]	Receiver line error Indication. Bit 6 is set to a '1' if one of three possible errors occurs in the RX process. With the corresponding interrupt enable bit active, one of PHY, CRC and Frame length errors let this bit go active. Bit 6 is cleared when the source of the error is cleared.	0
Tx Underrun	[5]	Transmit under-run interrupt pending. When corresponding interrupt enable bit is active, bit 5 is set to '1' if an under-run occurs in TX FIFO. Bit 5 is cleared by serving the under-run.	0
Last byte detect	[4]	Detects last byte of a frame interrupt pending. If the corresponding interrupt enable bit is active, bit 4 is set to '1' when the demodulation block detects the last byte of a received frame and the CRC decoding is finished. Bit 4 is cleared when it is read.	0
Rx overrun	[3]	RX FIFO over-run interrupt. When corresponding interrupt enable bit is set, bit3 is active, bit 3 is set to '1' when an overrun occurs in the RX FIFO. Bit 3 is cleared by serving the over-run.	0
Last byte read from Rx FIFO	[2]	RX FIFO last byte read interrupt. When corresponding interrupt enable bit is active, it is set to '1' when the CPU reads the last byte of a frame from the RX FIFO. It is cleared when it is read.	0
Tx FIFO below threshold	[1]	TX FIFO below threshold interrupt pending. Bit 1 is set to '1' when the transmitter FIFO level is below its threshold level.	0
Rx FIFO over threshold	[0]	RX FIFO over threshold interrupt pending. Bit 0 is set to '1' when the receiver FIFO level is equal to or above its threshold level.	0

**IrDA LINE STATUS REGISTER (IrDA\_LSR)**

Register	Address	R/W	Description	Reset Value
IrDA_LSR	0x41800014	R	IrDA line status register	0x03

IrDA_LSR	Bit	Description	Initial State
Tx empty	[7]	Transmitter empty. This bit is set to '1' when TX FIFO is empty and the transmitter front-end is idle.	1
Reserved	[6]	Reserved	0
Received last byte from Rx FIFO	[5]	Last byte received from RX FIFO. It is set to a '1' when the microcontroller reads the last byte of a frame from the RX FIFO and cleared when the MCU reads the IrDA_LSR register.	0
Frame length error	[4]	Frame length error. It is set to '1' when a frame exceeding the maximum frame length predefined by IrDA_RXFLL and IrDA_RXFLH register is received. This bit is cleared when the microcontroller reads the IrDA_LSR register. When this error is detected, current frame reception is terminated. Data receiving is stopped until the next BOF is detected. Bit 4 is cleared to '0' when the IrDA_LSR register is read by the microcontroller.	0
PHY error	[3]	PHY error. In FIR mode, It is set to a '1' when an illegal 4PPM symbol is received. In IrDA_MIR mode, if an abort pattern (more than 7 consecutive '1's) is received during reception, this bit is set to '1'. It is cleared when microcontroller reads the LSR register.	0
CRC error	[2]	CRC error. Bit 2 is set to '1' when a bad IrDA_CRC is detected on data receive. It is cleared to '0' when microcontroller reads the LSR register.	0
Reserved	[1]	Reserved	1
Rx FIFO empty	[0]	RX FIFO empty. It indicates that the RX FIFO is empty. When the state of RX FIFO turns into empty, it is set to '1'. When the RX FIFO is not empty, it is set to '0'.	1

## IrDA FIFO CONTROL REGISTER (IrDA\_FCR)

Register	Address	R/W	Description	Reset Value
IrDA_FCR	0x41800018	R/W	IrDA FIFO control register	0x00

IrDA_FCR	Bit	Description	Initial State			
Rx FIFO trigger level select	[7:6]	Receiver FIFO trigger level selection.		00		
		<b>Bit 7</b>	<b>Bit 6</b>		<b>16-Byte RX FIFO</b>	<b>64-Byte RX FIFO</b>
		0	0		01	01
		0	1		04	16
		1	0		08	32
		1	1	14	56	
FIFO size select	[5]	When set to '1', 64 bytes TX and RX FIFO are selected. When set to '0', 16 bytes TX and RX FIFO are selected.	0			
Reserved	[4]	Reserved	0			
Reserved	[3]	Reserved	0			
Tx FIFO reset	[2]	TX FIFO reset. When set to '1', bit 2 clears all bytes in the transmitter FIFO and reset its counter to '0'. A '1' written to bit 2 is self-clearing.	0			
Rx FIFO reset	[1]	RX FIFO reset. When set to '1', bit 1 clears all bytes in the receiver FIFO and reset its counter to '0'. A '1' written to bit 1 is self clearing.	0			
FIFO enable	[0]	FIFO enable. When set to '1', bit 0 enables both the transmitter and receiver FIFOs. Bit 0 must be a '1' when setting other IrDA_FCR bits. Changing bit 0 clears the FIFO.	0			





**IRDA TOTAL NUMBER OF DATA BYTES REMAINED IN RX FIFO (IRDA\_RXNO)**

Register	Address	R/W	Description	Reset Value
IrDA_RxNO	0x41800028	R	The total number of data bytes remained in Rx FIFO	0x00

IrDA_RxNO	Bit	Description	Initial State
Rx data total number	[7:0]	The total number of data bytes remained in Rx FIFO.	00

**IRDA TRANSMIT FRAME-LENGTH REGISTER LOW (IrDA\_TXFLL)**

Register	Address	R/W	Description	Reset Value
IrDA_TXFLL	0x4180002C	R/W	IrDA transmit frame-length register low	0x00

IrDA_TXFLL	Bit	Description	Initial State
Tx frame length low	[7:0]	TXFLL stores the lower 8 bits of the byte number of the frame to be transmitted.	00

**IRDA TRANSMIT FRAME-LENGTH REGISTER HIGH (IrDA\_TXFLH)**

Register	Address	R/W	Description	Reset Value
IrDA_TXFLH	0x41800030	R/W	IrDA transmit frame-length register high	0x00

IrDA_TXFLH	Bit	Description	Initial State
Tx frame length high	[7:0]	TXFLH stores the upper 8 bits of the byte number of the frame to be transmitted.	00

**IrDA RECEIVER FRAME-LENGTH REGISTER LOW (IrDA\_RXFLL)**

Register	Address	R/W	Description	Reset Value
IrDA_RXFLL	0x41800034	R/W	IrDA receive frame-length register low	0x00

IrDA_RXFLL	Bit	Description	Initial State
Rx frame length low	[7:0]	RXFLL stores the lower 8 bits of the maximum byte number of the frame to be received.	00

**IrDA RECEIVER FRAME-LENGTH REGISTER HIGH (IrDA\_RXFLH)**

Register	Address	R/W	Description	Reset Value
IrDA_RXFLH	0x41800038	R/W	IrDA receive frame-length register high	0x00

IrDA_RXFLH	Bit	Description	Initial State
Rx frame length high	[5:0]	TXFLL stores the upper 6 bits of the maximum byte number of the frame to be received.	00

# 13

## IIC-BUS INTERFACE

### OVERVIEW

The S3C24A0A RISC microprocessor can support a multi-master IIC-bus serial interface. A dedicated serial data line (SDA) and a serial clock line (SCL) carry information between bus masters and peripheral devices which are connected to the IIC-bus. The SDA and SCL lines are bi-directional.

In multi-master IIC-bus mode, multiple S3C24A0A RISC microprocessors can receive or transmit serial data to or from slave devices. The master S3C24A0A, which can initiate a data transfer over the IIC-bus, is responsible for terminating the transfer. Standard bus arbitration procedure is used in this IIC-bus in S3C24A0A.

To control multi-master IIC-bus operations, values must be written to the following registers:

- Multi-master IIC-bus control register, IICCON
- Multi-master IIC-bus control/status register, IICSTAT
- Multi-master IIC-bus Tx/Rx data shift register, IICDS
- Multi-master IIC-bus address register, IICADD
- Multi-master IIC-bus SDAOUT delay register, SDADLY

When the IIC-bus is free, the SDA and SCL lines should be both at High level. A High-to-Low transition of SDA can initiate a Start condition. A Low-to-High transition of SDA can initiate a Stop condition while SCL remains steady at High Level.

The Start and Stop conditions can always be generated by the master devices. A 7-bit address value in the first data byte, which is put onto the bus after the Start condition has been initiated, can determine the slave device which the bus master device has selected. The 8<sup>th</sup> bit determines the direction of the transfer (read or write).

Every data byte put onto the SDA line should total eight bits. The number of bytes which can be sent or received during the bus transfer operation is unlimited. Data is always sent from most-significant bit (MSB) first, and every byte should be immediately followed by an acknowledgement (ACK) bit.

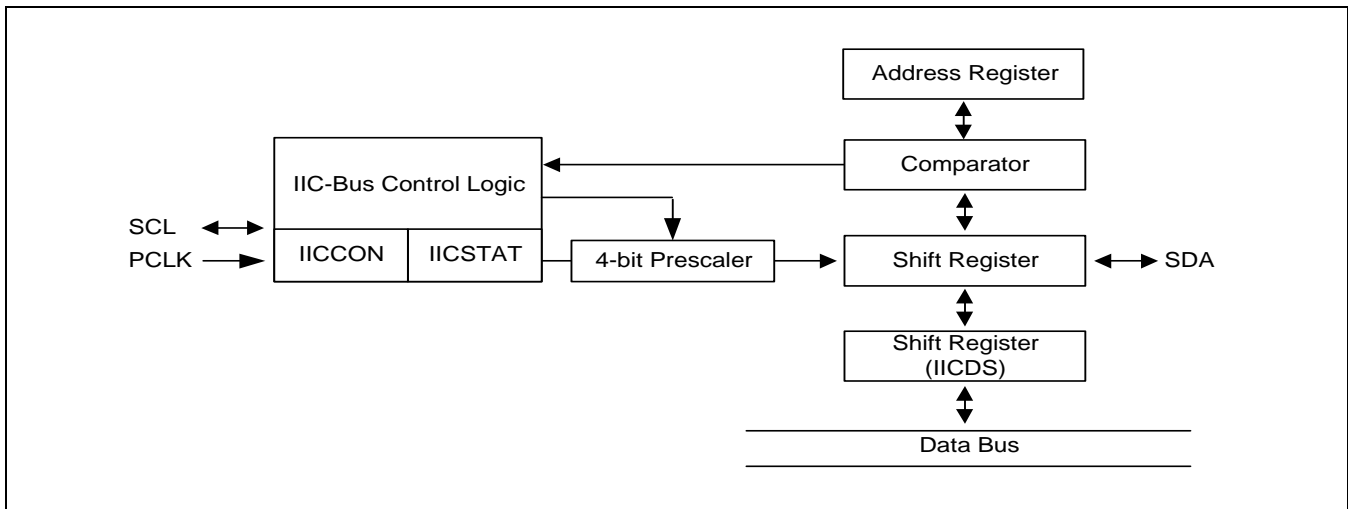

Figure 13-1. IIC-Bus Block Diagram

## THE IIC-BUS INTERFACE

The S3C24A0A IIC-bus interface has four operation modes:

- Master transmitter mode
- Master receive mode
- Slave transmitter mode
- Slave receive mode

Functional relationships among these operating modes are described below.

## START AND STOP CONDITIONS

When the IIC-bus interface is inactive, it is usually in slave mode. In other words, the interface should be in slave mode before detecting a Start condition on the SDA line. (A Start condition can be initiated with a High-to-Low transition of the SDA line while the clock signal of SCL is high) When the interface state is changed to the master mode, a data transfer on the SDA line can be initiated and SCL signal generated.

A Start condition can transfer a one-byte serial data over the SDA line, and a stop condition can terminate the data transfer. A stop condition is a Low-to-High transition of the SDA line while SCL is High. Start and Stop conditions are always generated by the master. The IIC-bus is busy when a Start condition is generated. A few clocks after a Stop condition, the IIC-bus will be free, again.

When a master initiates a Start condition, it should send a slave address to notify the slave device. The one byte of address field consists of a 7-bit address and 1-bit transfer direction indicators (that is, write or read). If bit 8 is 0, it indicates a write operation (transmit operation); if bit 8 is 1, it indicates a request for data read (receive operation).

The master will finish the transfer operation by transmitting a Stop condition. If the master wants to continue the data transmission to the bus, it should generate another Start condition as well as a slave address. In this way, the read-write operation can be performed in various formats.

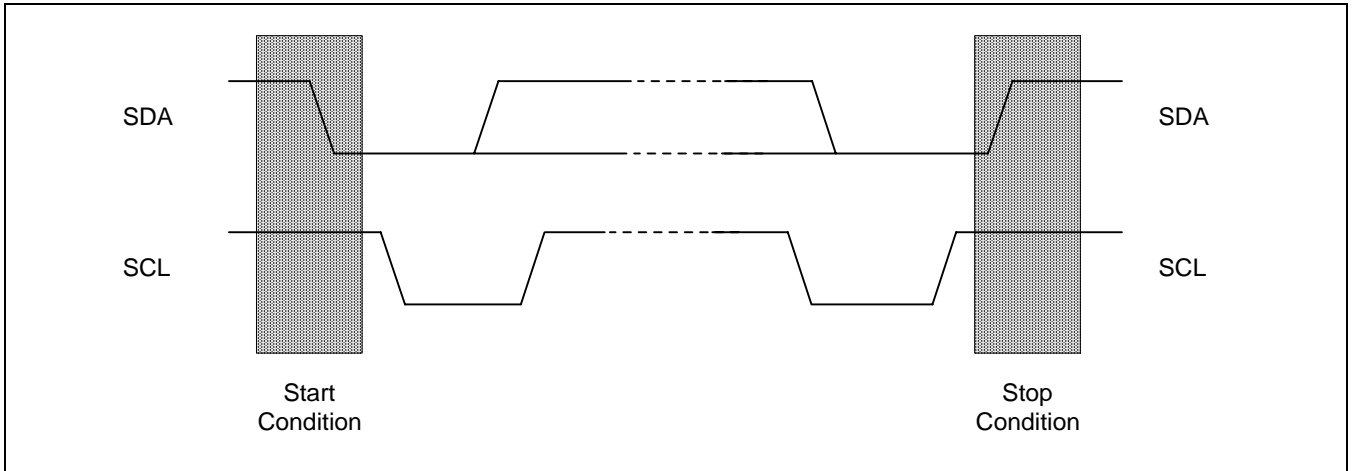
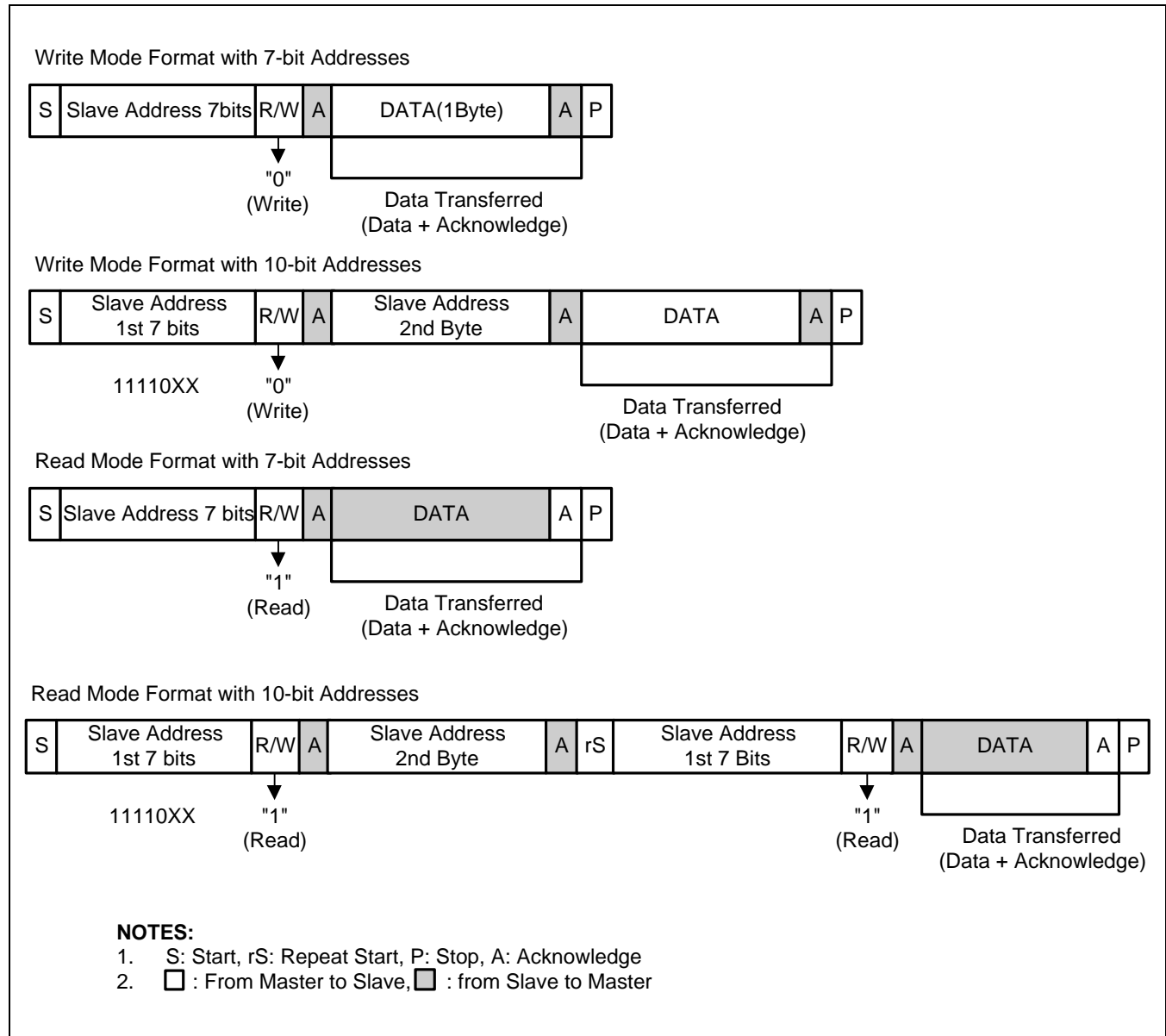

Figure 13-2. Start and Stop Condition

**DATA TRANSFER FORMAT**

Every byte placed on the SDA line should be eight bits in length. The number of bytes which can be transmitted per transfer is unlimited. The first byte following a Start condition should have the address field. The address field can be transmitted by the master when the IIC-bus is operating in master mode. Each byte should be followed by an acknowledgement (ACK) bit. The MSB bit of the serial data and addresses are always sent first.



**Figure 13-3. IIC-Bus Interface Data Format**

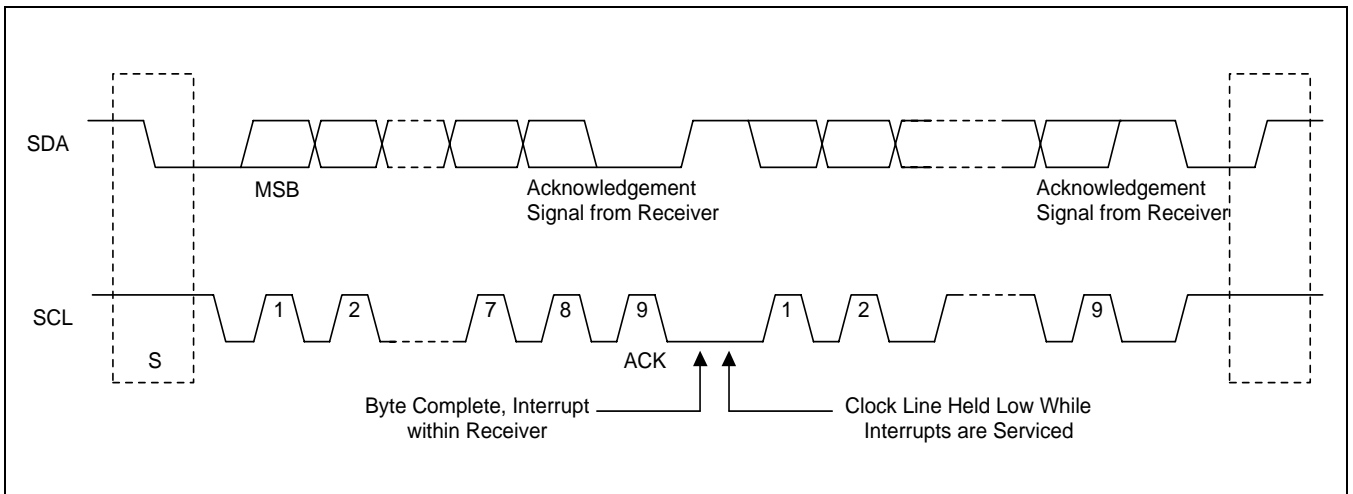

Figure 13-4. Data Transfer on the IIC-Bus

**ACK SIGNAL TRANSMISSION**

To finish a one-byte transfer operation completely, the receiver should send an ACK bit to the transmitter. The ACK pulse should occur at the ninth clock of the SCL line. Eight clocks are required for the one-byte data transfer. The master should generate the clock pulse required to transmit the ACK bit.

The transmitter should release the SDA line by making the SDA line High when the ACK clock pulse is received. The receiver should also drive the SDA line Low during the ACK clock pulse so that the SDA is Low during the High period of the ninth SCL pulse.

The ACK bit transmit function can be enabled or disabled by software (IICSTAT). However, the ACK pulse on the ninth clock of SCL is required to complete a one-byte data transfer operation.

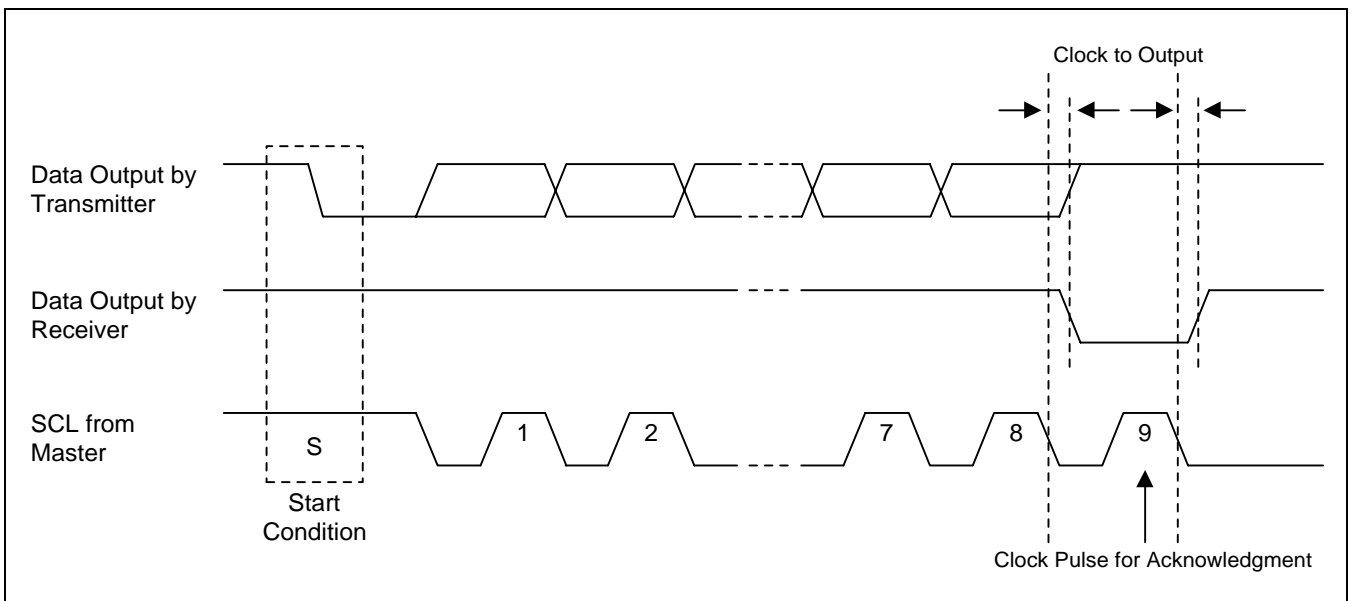

Figure 13-5. Acknowledge on the IIC-Bus



## READ-WRITE OPERATION

In the transmitter mode, after the data is transferred, the IIC-bus interface will wait until IICDS (IIC-bus Data Shift Register) is written by a new data. Until the new data is written, the SCL line will be held low. After the new data is written to IICDS register, the SCL line will be released. The S3C24A0A should hold the interrupt to identify the completion of current data transfer. After the CPU receives the interrupt request, it should write a new data into IICDS, again.

In the receive mode, after a data is received, the IIC-bus interface will wait until IICDS register is read. Until the new data is read out, the SCL line will be held low. After the new data is read out from IICDS register, the SCL line will be released. The S3C24A0A should hold the interrupt to identify the completion of the new data reception. After the CPU receives the interrupt request, it should read the data from IICDS.

## BUS ARBITRATION PROCEDURES

Arbitration takes place on the SDA line to prevent the contention on the bus between two masters. If a master with a SDA High level detects another master with a SDA active Low level, it will not initiate a data transfer because the current level on the bus does not correspond to its own. The arbitration procedure will be extended until the SDA line turns high.

However when the masters simultaneously lower the SDA line, each master should evaluate whether or not the mastership is allocated to itself. For the purpose of evaluation, each master should detect the address bits. While each master generates the slaver address, it should also detect the address bit on the SDA line because the lowering of SDA line is stronger than maintaining High on the line. For example, one master generates a Low as first address bit, while the other master is maintaining High. In this case, both masters will detect Low on the bus because Low is stronger than High even if first master is trying to maintain High on the line. When this happens, Low(as the first bit of address) -generating master will get the mastership and High(as the first bit of address) -generating master should withdraw the mastership. If both masters generate Low as the first bit of address, there should be arbitration for second address bit, again. This arbitration will continue to the end of last address bit.

## ABORT CONDITIONS

If a slave receiver can not acknowledge the confirmation of the slave address, it should hold the level of the SDA line High. In this case, the master should generate a Stop condition and to abort the transfer.

If a master receiver is involved in the aborted transfer, it should signal the end of the slave transmit operation by canceling the generation of an ACK after the last data byte received from the slave. The slave transmitter should then release the SDA to allow a master to generate a Stop condition.

## CONFIGURING THE IIC-BUS

To control the frequency of the serial clock (SCL), the 4-bit pre-scaler value can be programmed in the IICCON register. The IIC-bus interface address is stored in the IIC-bus address register, IICADD. (By default, the IIC-bus interface address is an unknown value.)

## FLOWCHARTS OF THE OPERATIONS IN EACH MODE

The following steps must be executed before any IIC Tx/Rx operations.

1. Write own slave address on IICADD register if needed.
2. Set IICCON Register.
  - a. Enable interrupt
  - b. Define SCL period
2. Set IICSTAT to enable Serial Output

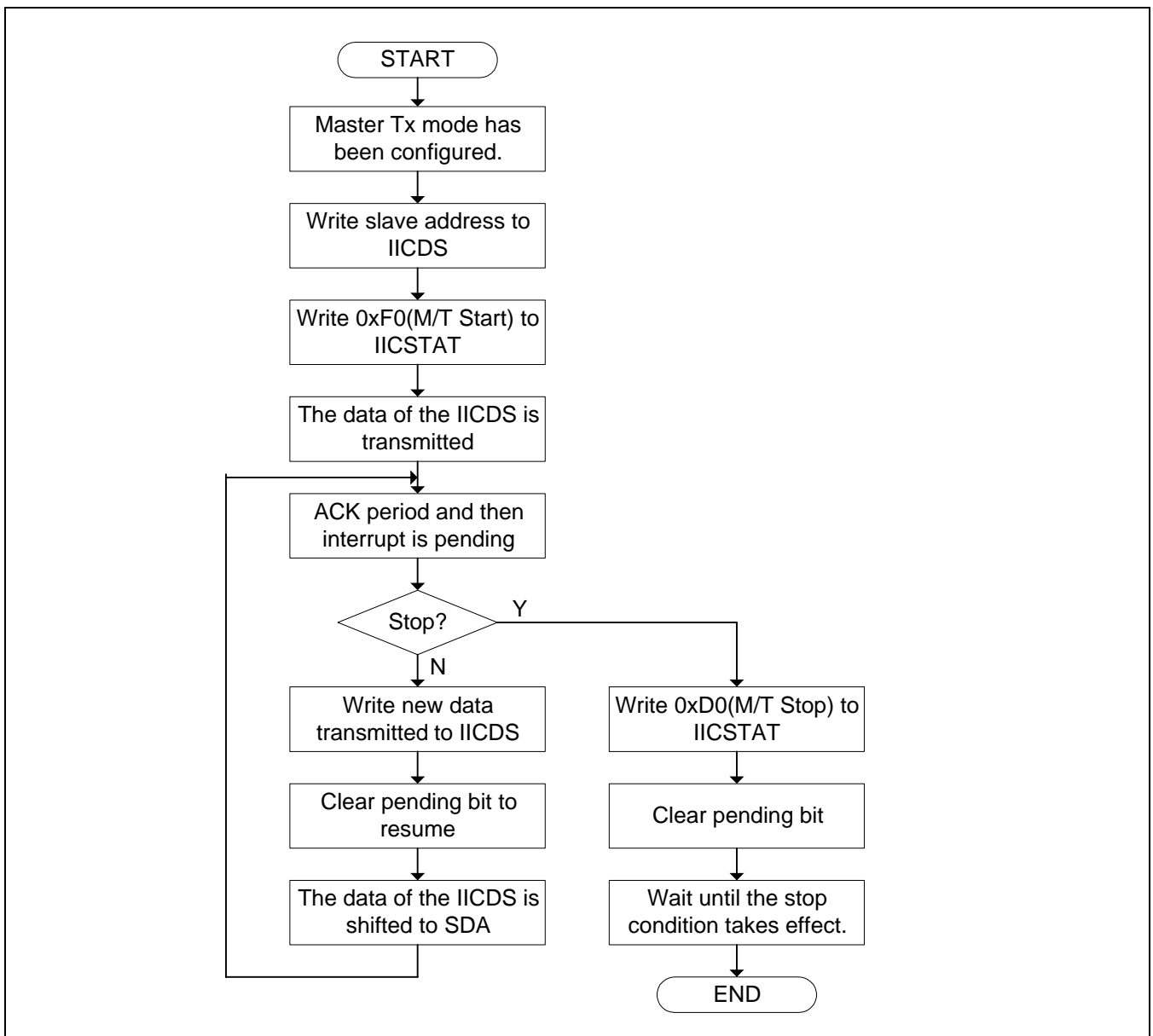

Figure 13-6. Operations for Master / Transmitter Mode

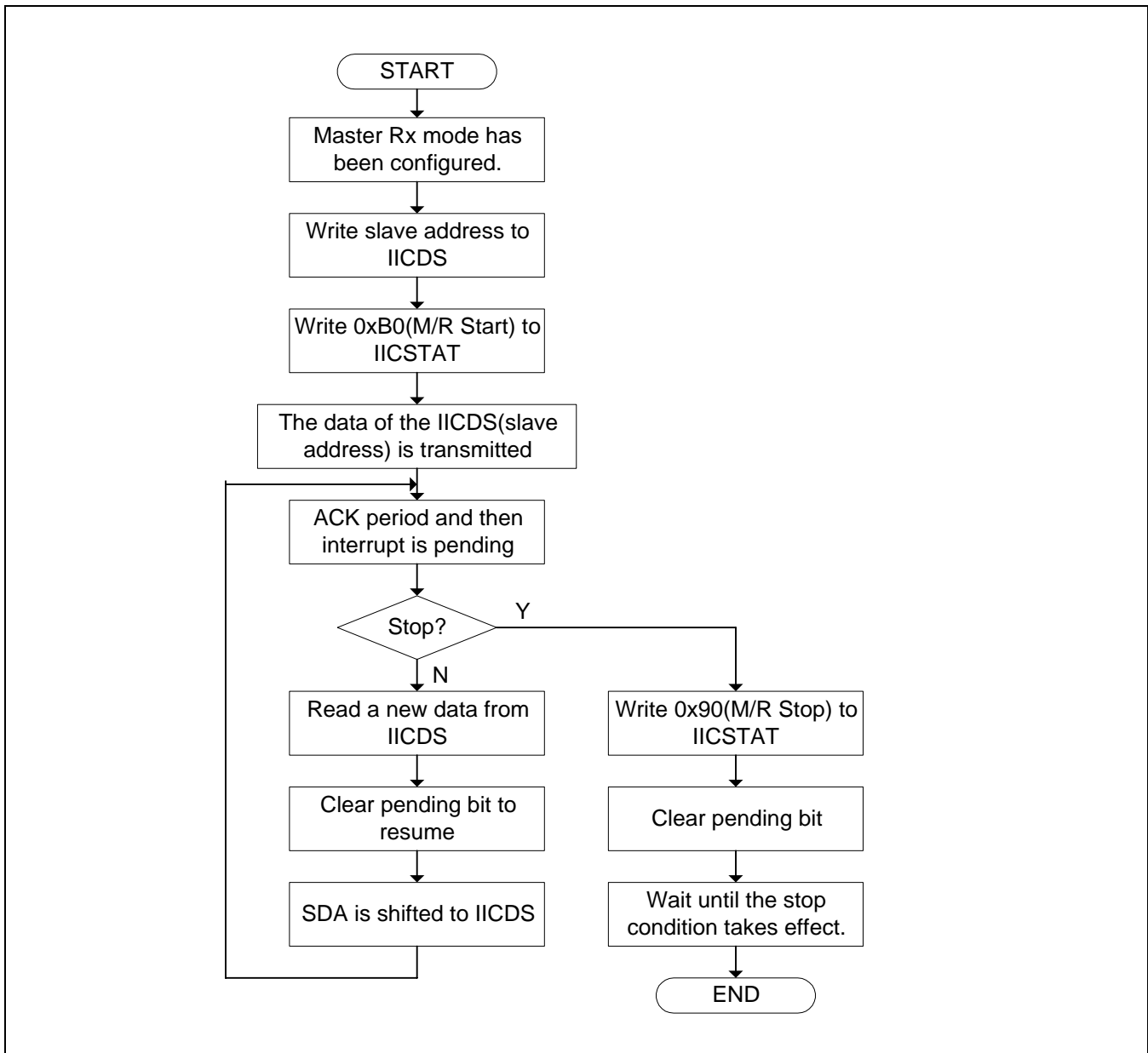

Figure 13-7. Operations for Master / Receiver Mode

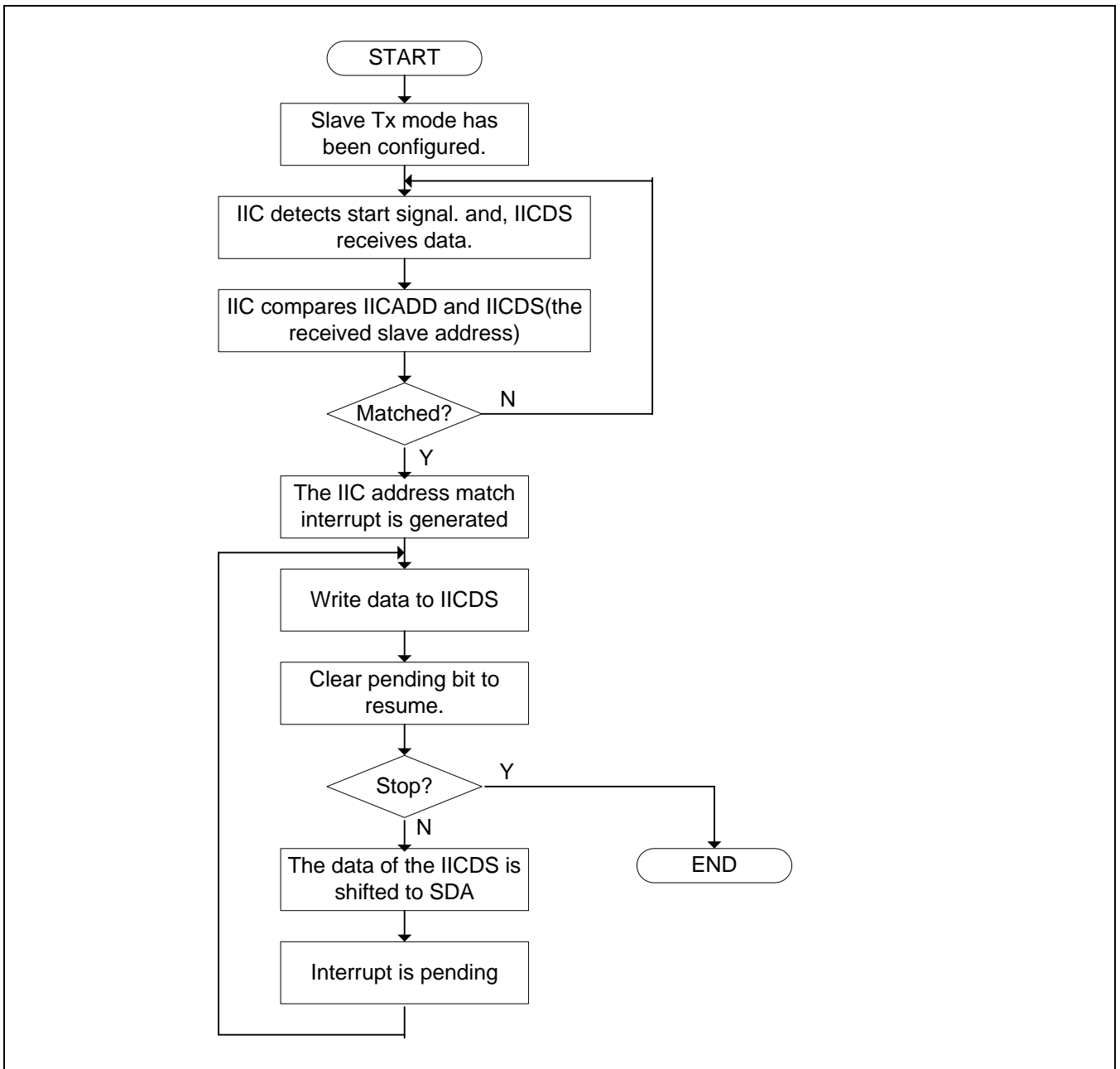

Figure 13-8. Operations for Slave / Transmitter Mode

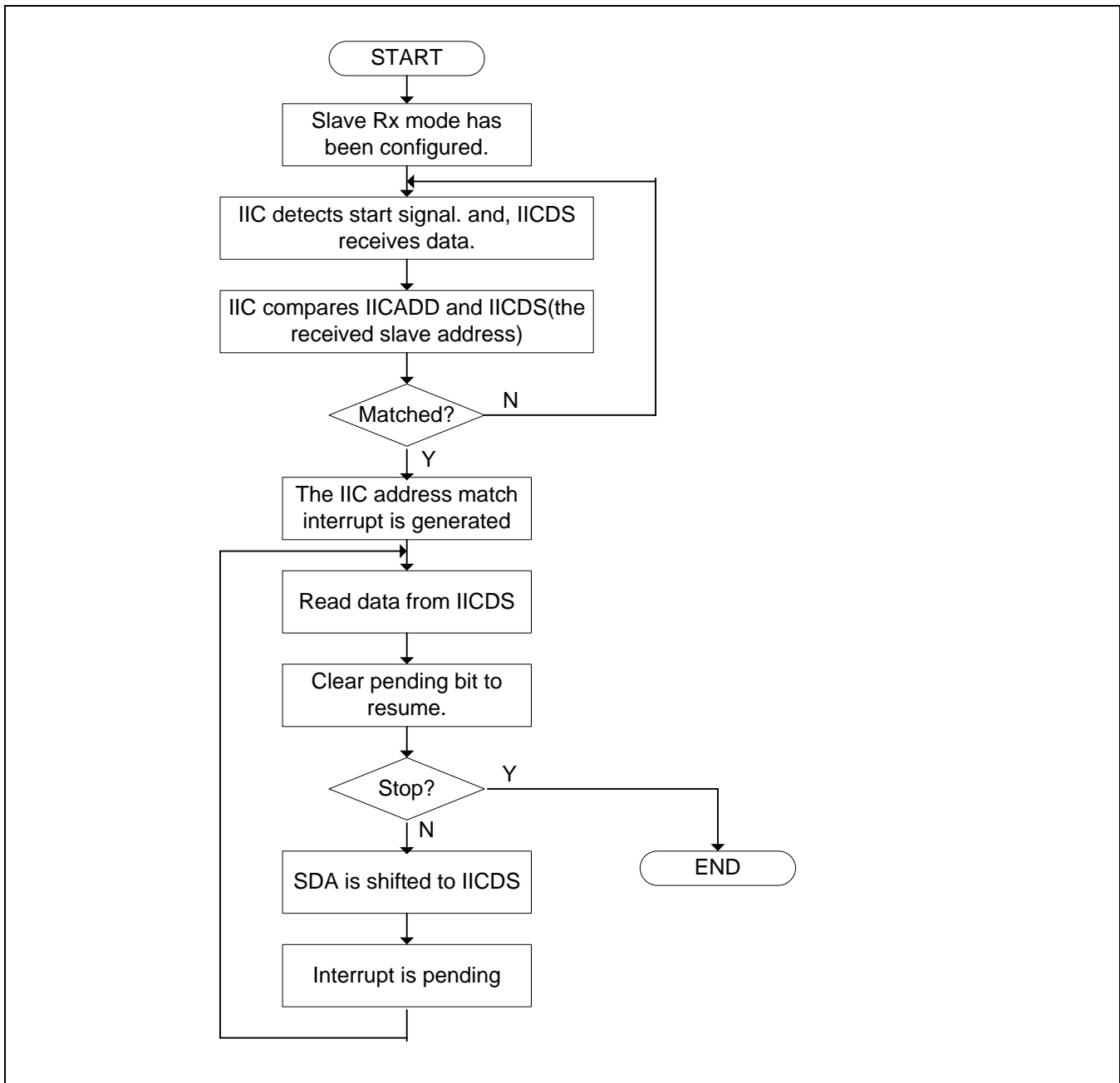

Figure 13-9. Operations for Slave / Receiver Mode

## IIC-BUS INTERFACE SPECIAL REGISTERS

### MULTI-MASTER IIC-BUS CONTROL REGISTER (IICCON)

Register	Address	R/W	Description	Reset Value
IICCON	0x44600000	R/W	IIC-Bus control register	0x0X

IICCON	Bit	Description	Initial State
Acknowledge generation <sup>(1)</sup>	[7]	IIC-bus acknowledge enable bit 0 = Disable 1 = Enable  In Tx mode, the IICSDA is free in the ack time. In Rx mode, the IICSDA is L in the ack time.	0
Tx clock source selection	[6]	Source clock of IIC-bus transmit clock prescaler selection bit 0 = IICCLK = $f_{PCLK}/16$ 1 = IICCLK = $f_{PCLK}/512$	0
Tx/Rx Interrupt <sup>(5)</sup>	[5]	IIC-Bus Tx/Rx interrupt enable/disable bit 0 = Disable, 1 = Enable	0
Interrupt pending flag <sup>(2) (3)</sup>	[4]	IIC-bus Tx/Rx interrupt pending flag. Writing 1 is impossible. When this bit is read as 1, the IICSDA is tied to L and the IIC is stopped. To resume the operation, clear this bit as 0.  0 = 1) No interrupt pending(when read), 2) Clear pending condition & Resume the operation (when write). 1 = 1) Interrupt is pending (when read) 2) N/A (when write)	0
Transmit clock value <sup>(4)</sup>	[3:0]	IIC-Bus transmit clock prescaler IIC-Bus transmit clock frequency is determined by this 4-bit prescaler value, according to the following formula: Tx clock = $IICCLK/(IICCON[3:0]+1)$	Undefined

#### NOTES:

- Interfacing with EEPROM, the ack generation may be disabled before reading the last data in order to generate the STOP condition in Rx mode.
- A IIC-bus interrupt occurs 1)when a 1-byte transmit or receive operation is completed, 2)when a general call or a slave address match occurs, or 3) if bus arbitration fails.
- To time the setup time of IICSDA before IICSDA rising edge, IICSDA has to be written before clearing the IIC interrupt pending bit.
- IICCLK is determined by IICCON[6].  
Tx clock can vary by SCL transition time.  
When IICCON[6]=0, IICCON[3:0]=0x0 or 0x1 is not available.
- If the IICCON[5]=0, IICCON[4] does not operate correctly.  
So, It is recommended to set IICCON[4]=1, although you does not use the IIC interrupt.

**MULTI-MASTER IIC-BUS CONTROL/STATUS REGISTER (IICSTAT)**

Register	Address	R/W	Description	Reset Value
IICSTAT	0x44600004	R/W	IIC-Bus control/status register	0x0

IICSTAT	Bit	Description	Initial State
Mode selection	[7:6]	IIC-bus master/slave Tx/Rx mode select bits: 00 = Slave receive mode 01 = Slave transmit mode 10 = Master receive mode 11 = Master transmit mode	00
Busy signal status / START STOP condition	[5]	IIC-Bus busy signal status bit: 0 = read) Not busy write) STOP signal generate(only for master) 1 = read) Busy write) START signal generate(only for master) The data in IICDS will be transferred automatically just after the start signal.	0
Serial output	[4]	IIC-bus data output enable/disable bit: 0 = Disable Rx/Tx      1 = Enable Rx/Tx	0
Arbitration status flag	[3]	IIC-bus arbitration procedure status flag bit: 0 = Bus arbitration successful 1 = Bus arbitration failed during serial I/O	0
Address-as-slave status flag	[2]	IIC-bus address-as-slave status flag bit: 0 = Cleared when START/STOP condition was detected 1 = Received slave address matches the address value in the IICADD.	0
Address zero status flag	[1]	IIC-bus address zero status flag bit: 0 = Cleared when START/STOP condition was detected. 1 = Received slave address is 00000000b	0
Last-received bit status flag	[0]	IIC-bus last-received bit status flag bit 0 = Last-received bit is 0 (ACK was received) 1 = Last-received bit is 1 (ACK was not received)	0

**MULTI-MASTER IIC-BUS ADDRESS REGISTER (IICADD)**

Register	Address	R/W	Description	Reset Value
IICADD	0x44600008	R/W	IIC-Bus address register	0xXX

IICADD	Bit	Description	Initial State
Slave address	[7:0]	7-bit slave address, latched from the IIC-bus : When serial output enable = 0 in the IICSTAT, IICADD is write-enabled. The IICADD value can be read any time, regardless of the current serial output enable bit (IICSTAT) setting. Slave address = [7:1] Not mapped = [0]	XXXXXXXX

**MULTI-MASTER IIC-BUS TRANSMIT/RECEIVE DATA SHIFT REGISTER (IICDS)**

Register	Address	R/W	Description	Reset Value
IICDS	0x4460000C	R/W	IIC-Bus transmit/receive data shift register	0xXX

IICDS	Bit	Description	Initial State
Data shift	[7:0]	8-bit data shift register for IIC-bus Tx/Rx operation : When serial output enable = 1 in the IICSTAT, IICDS is write-enabled. The IICDS value can be read any time, regardless of the current serial output enable bit (IICSTAT) setting	XXXXXXXX

**MULTI-MASTER IIC-BUS SDAOUT DELAY REGISTER (SDADLY)**

Register	Address	R/W	Description	Reset Value
SDADLY	0x44600010	R/W	IIC-Bus SDAOUT delay register	0x0

SDADLY	Bit	Description	Initial State
FLTEN	[2]	SCL & SDA line input filter enable 0 = Disable                      1 = Enable	0
SDADLY	[1:0]	Delay setting for IIC-bus SDA output operation: 00 = 0-cycle                      01 = 5-cycle 10 = 10-cycle                      11 = 15-cycle	0





## NOTES

---

13-14

Preliminary product information describe products that are in development, for which full characterization data and associated errata are not yet available. Specifications and information herein are subject to change without notice.

# 14

## IIS-BUS INTERFACE

### OVERVIEW

Many digital audio systems are introduced into the consumer audio market, including compact disc, digital audio tapes, digital sound processors, and digital TV sound. The S3C24A0A IIS (Inter-IC Sound) bus interface can be used to implement a CODEC interface to an external 8/16-bit stereo audio CODEC IC for mini-disc and portable applications. It supports the IIS bus data format and MSB-justified data format. IIS bus interface provides DMA transfer mode for FIFO access instead of an interrupt. It can transmit or receive data simultaneously as well as transmit or receive data only.

### FEATURES

- IIS, MSB-justified format compatible
- 8/16-bit data per channel
- 16, 32, 48fs(sampling frequency) serial bit clock per channel
- 256, 384fs master clock
- Programmable frequency divider for master clock and CODEC clock
- 128 bytes(2 X 64) FIFO for transmit and receive
- Normal and DMA transfer mode

### BLOCK DIAGRAM

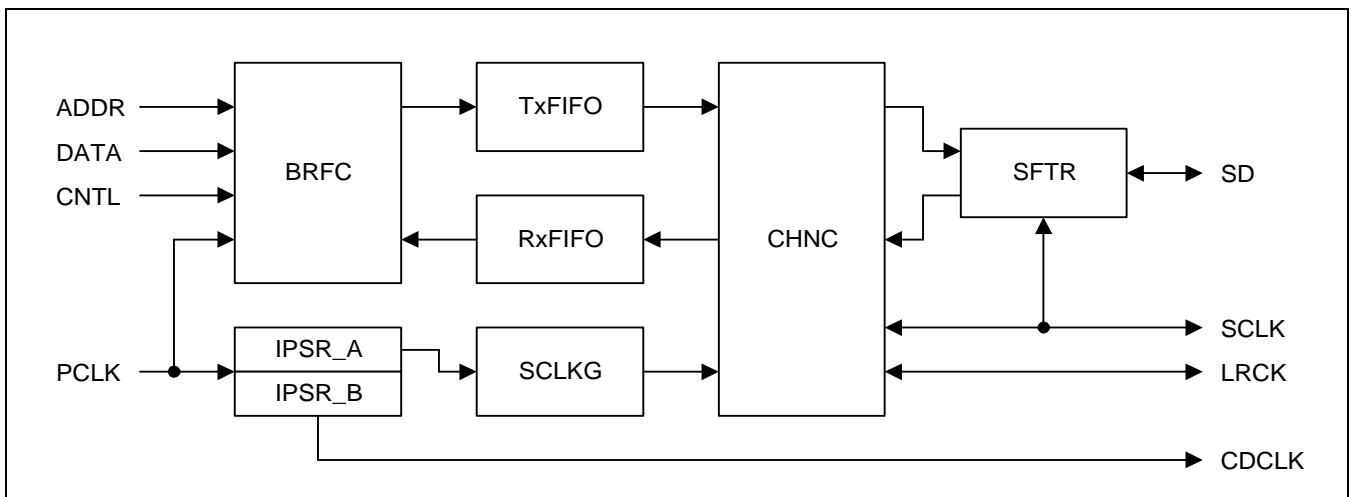

Figure 14-1. IIS-Bus Block Diagram

## FUNCTIONAL DESCRIPTIONS

Bus interface, register bank, and state machine(BRFC) - Bus interface logic and FIFO access are controlled by the state machine.

5-bit dual prescaler(IPSR) - One prescaler is used as the master clock generator of the IIS bus interface and the other is used as the external CODEC clock generator.

64-byte FIFOs(TxFIFO, RxFIFO) - In transmit data transfer, data are written to TxFIFO, and, in the receive data transfer, data are read from RxFIFO.

Master IISCLK generator(SCLKG) - In master mode, serial bit clock is generated from the master clock.

Channel generator and state machine(CHNC) - IISCLK and IISLRCK are generated and controlled by the channel state machine.

16-bit shift register(SFTR) - Parallel data is shifted to serial data output in the transmit mode, and serial data input is shifted to parallel data in the receive mode.

## TRANSMIT OR RECEIVE ONLY MODE

### Normal Transfer

IIS control register has FIFO ready flag bits for transmit and receive FIFO. When FIFO is ready to transmit data, the FIFO ready flag is set to '1' if transmit FIFO is not empty.

If transmit FIFO is empty, FIFO ready flag is set to '0'. When receive FIFO is not full, the FIFO ready flag for receive FIFO is set to '1'; it indicates that FIFO is ready to receive data. If receive FIFO is full, FIFO ready flag is set to '0'. These flags can determine the time that CPU is to write or read FIFOs. Serial data can be transmitted or received while CPU is accessing transmit and receive FIFOs in this way.

### DMA TRANSFER

In this mode, transmit or receive FIFO access is made by the DMA controller. DMA service request in transmit or receive mode is made by the FIFO ready flag automatically.

## TRANSMIT AND RECEIVE MODE

In this mode, IIS bus interface can transmit and receive data simultaneously.

## AUDIO SERIAL INTERFACE FORMAT

### IIS-BUS FORMAT

The IIS bus has four lines, serial data input(IISDI), serial data output(IISDO), left/right channel select(IISLRCK), and serial bit clock(IISCLK); the device generating IISLRCK and IISCLK is the master.

Serial data is transmitted in 2's complement with the MSB first. The MSB is transmitted first because the transmitter and receiver may have different word lengths. It is not necessary for the transmitter to know how many bits the receiver can handle, nor does the receiver need to know how many bits are being transmitted.

When the system word length is greater than the transmitter word length, the word is truncated (least significant data bits are set to '0') for data transmission. If the receiver is sent more bits than its word length, the bits after the LSB are ignored. On the other hand, if the receiver is sent fewer bits than its word length, the missing bits are set to zero internally. And so, the MSB has a fixed position, whereas the position of the LSB depends on the word length. The transmitter always sends the MSB of the next word at one clock period after the IISLRCK change.

Serial data sent by the transmitter may be synchronized with either the trailing (HIGH to LOW) or the leading (LOW to HIGH) edge of the clock signal. However, the serial data must be latched into the receiver on the leading edge of the serial clock signal, and so there are some restrictions when transmitting data that is synchronized with the leading edge.

The LR channel select line indicates the channel being transmitted. IISLRCK may change either on a trailing or leading edge of the serial clock, but it does not need to be symmetrical. In the slave, this signal is latched on the leading edge of the clock signal. The IISLRCK line changes one clock period before the MSB is transmitted. This allows the slave transmitter to derive synchronous timing of the serial data that will be set up for transmission. Furthermore, it enables the receiver to store the previous word and clear the input for the next word.

### MSB(LEFT) JUSTIFIED

MSB / left justified bus has the same lines as the IIS format. It is only different with the IIS bus that transmitter always sends the MSB of the next word when the IISLRCK change.

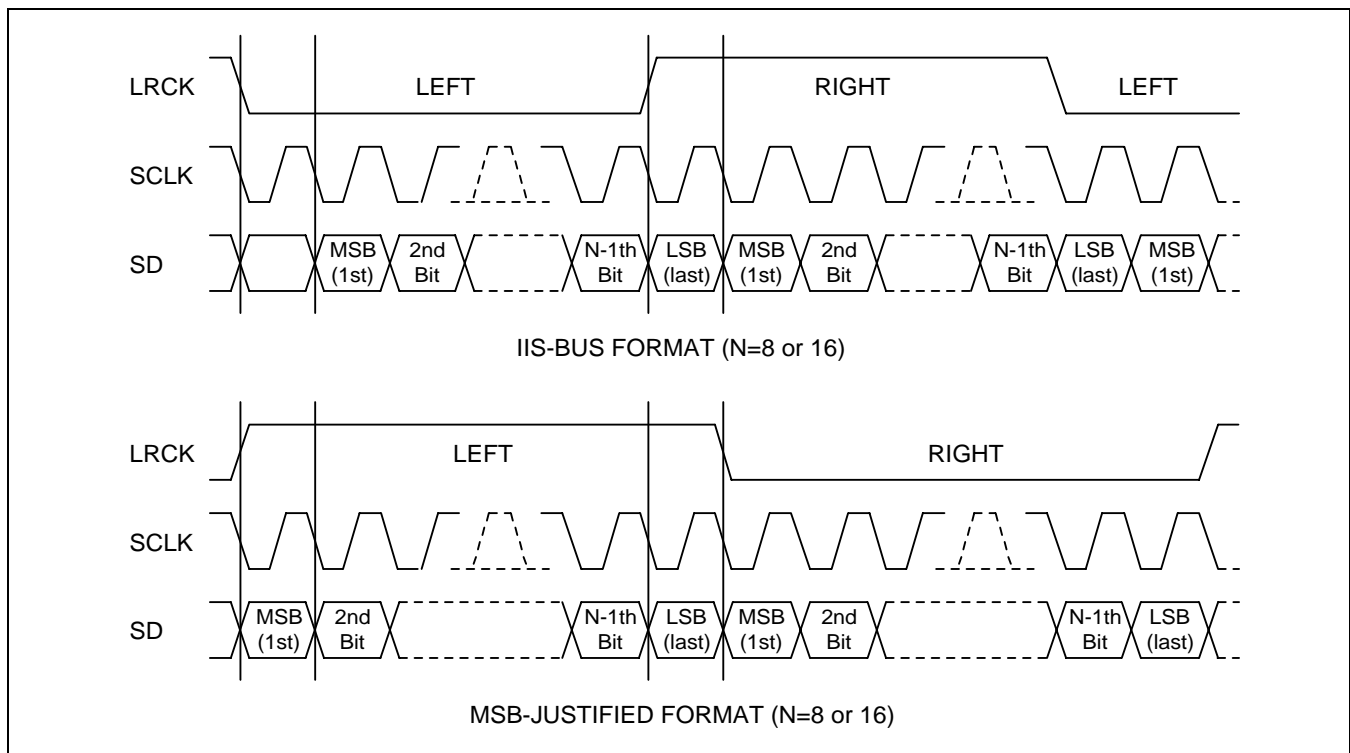

Figure 14-2. IIS-Bus and MSB(Left)-justified Data Interface Formats

**SAMPLING FREQUENCY AND MASTER CLOCK**

Master clock frequency (PCLK) can be selected by sampling frequency as shown in Table 21-1. Because PCLK is made by IIS prescaler, the prescaler value and PCLK type(256 or 384fs) should be determined properly. Serial bit clock frequency type(16/32/48fs) can be selected by the serial bit per channel and PCLK as shown in Table 21-2.

Table 14-1. CODEC Clock (IISCDCLK = 256 or 384fs)

IISLRCK (fs)	8.000 kHz	11.025 kHz	16.000 kHz	22.050 kHz	32.000 kHz	44.100 kHz	48.000 kHz	64.000 kHz	88.200 kHz	96.000 kHz
IISCDCLK (MHz)	256fs									
	2.0480	2.8224	4.0960	5.6448	8.1920	11.2896	12.2880	16.3840	22.5792	24.5760
IISCDCLK (MHz)	384fs									
	3.0720	4.2336	6.1440	8.4672	12.2880	16.9344	18.4320	24.5760	33.8688	36.8640

Table 14-2. Usable Serial Bit Clock Frequency (IISCLK = 16 or 32 or 48fs)

Serial Bit Per Channel	8-Bit	16-Bit
Serial clock frequency (IISCLK)		
@IISCDCLK = 256fs	16fs, 32fs	32fs
@IISCDCLK = 384fs	16fs, 32fs, 48fs	32fs, 48fs

## IIS-BUS INTERFACE SPECIAL REGISTERS

### IIS CONTROL REGISTER (IISCON)

Register	Address	R/W	Description	Reset Value
IISCON	0x44700000	R/W	IIS control register	0x100

IISCON	Bit	Description	Initial State
Left/Right channel index (Read only)	[8]	0 = Left 1 = Right	1
Transmit FIFO ready flag (Read only)	[7]	0 = Empty 1 = Not empty	0
Receive FIFO ready flag (Read only)	[6]	0 = Full 1 = Not full	0
Transmit DMA service request	[5]	0 = Disable 1 = Enable	0
Receive DMA service request	[4]	0 = Disable 1 = Enable	0
Transmit channel idle command	[3]	In Idle state the IISLRCK is inactive(Pause Tx) 0 = Not idle 1 = Idle	0
Receive channel idle command	[2]	In Idle state the IISLRCK is inactive(Pause Rx) 0 = Not idle 1 = Idle	0
IIS prescaler	[1]	0 = Disable 1 = Enable	0
IIS interface	[0]	0 = Disable (stop) 1 = Enable (start)	0

**IIS MODE REGISTER (IISMOD)**

Register	Address	R/W	Description	Reset Value
IISMOD	0x44700004	R/W	IIS mode register	0x0

IISMOD	Bit	Description	Initial State
Master Clock Select	[9]	Master Clock Source Select Selects the source clock used to create the master clock 0: Source Clock is PCLK 1: Source Clock is the External Codec Input pin(XgpIO[8]) The selected clock is feed into the input of the prescaler unit	0
Master/slave mode select	[8]	0 = Master mode (IISLRCK and IISCLK are output mode) 1 = Slave mode (IISLRCK and IISCLK are input mode)	0
Transmit/receive mode select	[7:6]	00 = No transfer 01 = Receive mode 10 = Transmit mode 11 = Transmit and receive mode	00
Active level of left/right channel	[5]	0 = Low for left channel (High for right channel) 1 = High for left channel (Low for right channel)	0
Serial interface format	[4]	0 = IIS compatible format 1 = MSB(Left)-justified format	0
Serial data bit per channel	[3]	0 = 8-bit      1 = 16-bit	0
Master clock frequency select	[2]	0 = 256fs      1 = 384fs (fs: sampling frequency)	0
Serial bit clock frequency select	[1:0]	00 = 16fs      01 = 32fs 10 = 48fs      11 = N/A	00

**IIS PRESCALER REGISTER (IISPSR)**

Register	Address	R/W	Description	Reset Value
IISPSR	0x44700008	R/W	IIS prescaler register	0x0

IISPSR	Bit	Description	Initial State
Prescaler control A	[9:5]	Data value: 0 ~ 31 <b>Note:</b> Prescaler A makes the master clock that is used the internal block and division factor is N+1.	00000
Prescaler control B	[4:0]	Data value: 0 ~ 31 <b>Note:</b> Prescaler B makes the master clock that is used the external block and division factor is N+1.	00000

**IIS FIFO CONTROL REGISTER (IISFCON)**

Register	Address	R/W	Description	Reset Value
IISFCON	0x4470000C	R/W	IIS FIFO interface register	0x0

IISFCON	Bit	Description	Initial State
Transmit FIFO access mode select	[15]	0 = Normal 1 = DMA	0
Receive FIFO access mode select	[14]	0 = Normal 1 = DMA	0
Transmit FIFO	[13]	0 = Disable 1 = Enable	0
Receive FIFO	[12]	0 = Disable 1 = Enable	0
Transmit FIFO data count (Read only)	[11:6]	Data count value = 0 ~ 32	000000
Receive FIFO data count (Read only)	[5:0]	Data count value = 0 ~ 32	000000



**IIS FIFO REGISTER (IISFIFO)**

IIS bus interface contains two 64-byte FIFO for transmit and receive mode. Each FIFO has 16-width and 32-depth form, which allows the FIFO to handles data by halfword unit regardless of valid data size. Transmit and receive FIFO access is performed through FIFO entry; the address of FENTRY is 0x44700010

Register	Address	R/W	Description	Reset Value
IISFIFO	0x44700010	R/W	IIS FIFO register	0x0

IISFIFO	Bit	Description	Initial State
FENTRY	[15:0]	Transmit/Receive data for IIS	0x0

# 15

## SPI INTERFACE

### OVERVIEW

The S3C24A0A Serial Peripheral Interface(SPI) can interface the serial data transfer. There are two SPI in S3C24A0A and each SPI has two 8bit shift register for transmission and receiving, respectively. During an SPI transfer, data is simultaneously transmitted (shifted out serially) and received (shifted in serially) 8bit serial data at a frequency determined by its corresponding control register settings. If you want only to transmit, you may treat the received data as dummy. Otherwise, if you want only to receive, you should transmit dummy '1' data.

There are 4 I/O pin signals associated with SPI transfers: the SCK, the MISO data line, the MOSI data line, and the active low /SS pin(input).

### FEATURES

- SPI Protocol(ver 2.11) compatible
- 8-bit Shift Register for transmit
- 8-bit Shift Register for receive
- 8-bit Prescaler logic
- Polling, Interrupt, and DMA transfer mode



BLOCK DIAGRAM

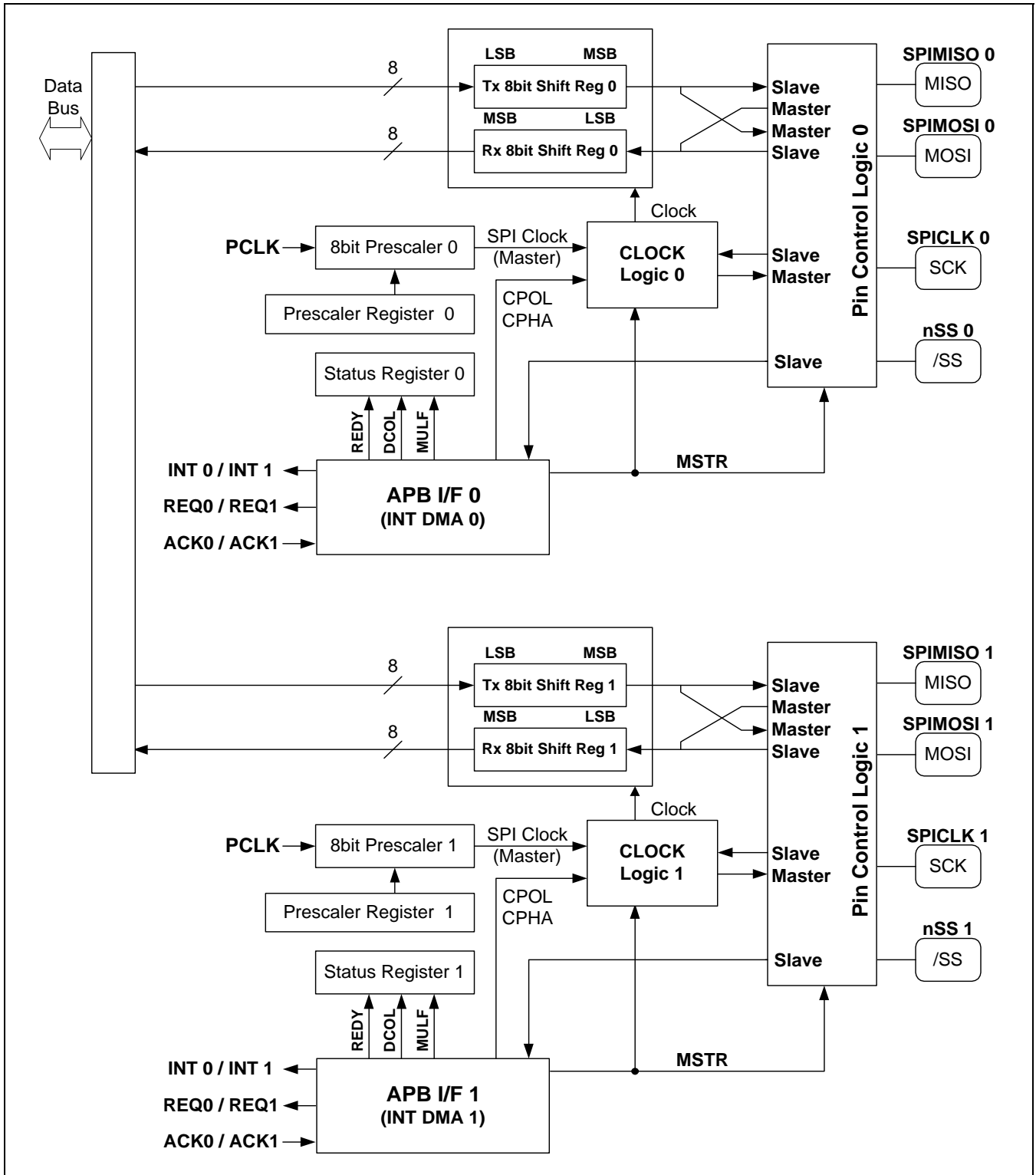

Figure 15-1. SPI Block Diagram

## SPI OPERATION

Using the SPI interface, 8-bit data can be sending and receiving data simultaneously with an external device. A serial clock line synchronizes shifting and sampling of the information on the two serial data lines. When SPI is the master, transmission frequency can be controlled by setting the appropriate bit to SPPREn register. You can modify its frequency to adjust the baud rate data register value. When SPI is a slave, other master supplies the clock. When a programmer writes byte data to SPTDATn register, SPI transmit and receive operation will start simultaneously. In some cases, nSS should be activated before writing byte data to SPTDATn.

### Programming Procedure

When a byte data is written into the SPTDATn register, SPI starts to transmit if ENSCK and MSTR of SPCONn register are set. There is a typical programming procedure to operate an SPI card.

To program the SPI modules, follow these basic steps :

1. Set Baud Rate Prescaler Register (SPPREn)
2. Set SPCONn to configure properly the SPI module
3. Write data 0xFF to SPTDATn 10 times in order to initialize MMC or SD card
4. Set a GPIO pin, which acts as nSS, to low to activate the MMC or SD card.
5. Tx data → Check the status of Transfer Ready flag (REDY=1), and then write data to SPTDATn.
6. Rx data(1) : SPCONn's TAGD bit disable = normal mode  
→ write 0xFF to SPTDATn, then confirm REDY to set, and then read data from Read Buffer
7. Rx data(2) : SPCONn's TAGD bit enable = Tx Auto Garbage Data mode  
→ confirm REDY to set, and then read data from Read Buffer(then automatically start to transfer)
8. Set a GPIO pin, which acts as nSS, to high, to deactivate MMC or SD card.



**SPI Transfer Format**

S3C24A0A supports 4 different format to transfer the data. Four waveforms are shown for SPICLK.

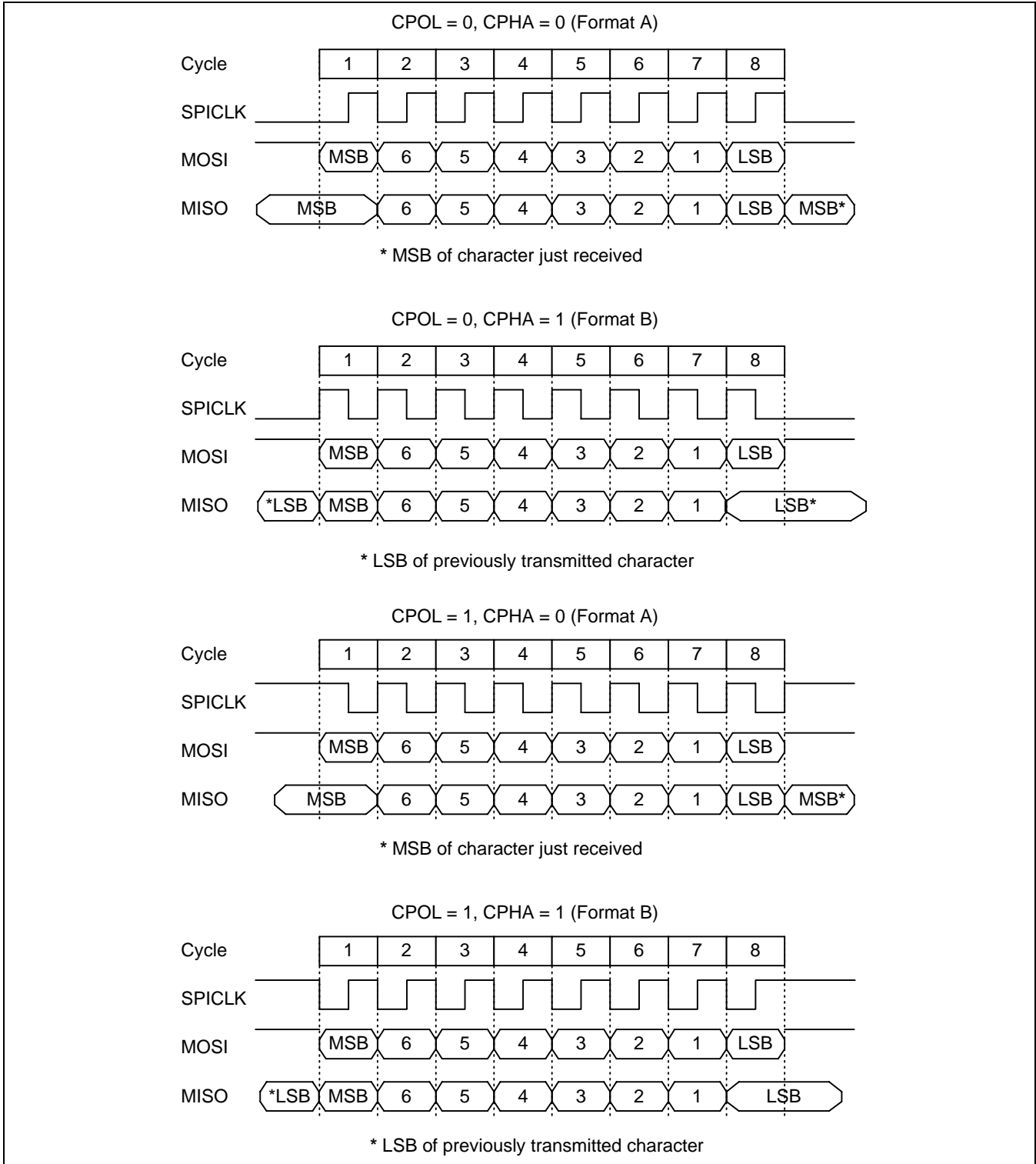

Figure 15-2. SPI Transfer Format



**Steps for Transmit by DMA**

1. The SPI is configured as DMA mode.
2. DMA is configured properly.
3. The SPI requests DMA service.
4. DMA transmits 1byte data to the SPI.
5. The SPI transmits the data to card.
6. Go to step 3 until DMA count is 0.
7. The SPI is configured as interrupt or polling mode with SMOD bits.

**Steps for Receive by DMA**

1. The SPI is configured as DMA start with SMOD bits and setting TAGD bit.
2. DMA is configured properly.
3. The SPI receives 1byte data from card.
4. The SPI requests DMA service.
5. DMA receives the data from the SPI.
6. Write data 0xFF automatically to SPTDATn.
7. Go to step 4 until DMA count is 0.
8. The SPI is configured as polling mode with SMOD bits and clearing TAGD bit.
9. If SPSTAn's REDY flag is set, then read the last byte data.

**NOTE**

Total received data = DMA TC values + The last data in polling mode(step 9). First DMA received data is dummy, so user can neglect that.

## SPI SPECIAL REGISTERS

### SPI CONTROL REGISTER

Register	Address	R/W	Description	Reset Value
SPCON0	0x44500000	R/W	SPI channel 0 control register	0x00
SPCON1	0x44500020	R/W	SPI channel 1 control register	0x00

SPCONn	Bit	Description	Initial State
SPI mode select (SMOD)	[6:5]	Determines how and by what SPTDAT is read/written 00 = Polling mode,      01 = Interrupt mode 10 = DMA mode,        11 = Reserved	00
SCK enable (ENSCK)	[4]	Determines what you want SCK enable or not (only master) 0 = Disable,            1 = Enable	0
Master/Slave select (MSTR)	[3]	Determines what mode you want master or slave 0 = Slave,              1 = Master <b>Note:</b> In slave mode, there should be set up time for master to initiate Tx / Rx.	0
Clock polarity select (CPOL)	[2]	Determines an active high or active low clock. 0 = Active high,        1 = Active low	0
Clock phase select (CPHA)	[1]	This bit selects one of two fundamentally different transfer formats. 0 = Format A,            1 = Format B	0
Tx auto garbage data mode enable (TAGD)	[0]	This bit decides whether the receiving data only needs or not. 0 = Normal mode,        1 = Tx auto garbage data mode <b>Note:</b> In normal mode, you only want to receive data, you should transmit dummy 0xFF data.	0





## SPI STATUS REGISTER

Register	Address	R/W	Description	Reset Value
SPSTA0	0x44500004	R	SPI channel 0 status register	0x01
SPSTA1	0x44500024	R	SPI channel 1 status register	0x01

SPSTAn	Bit	Description	Initial State
Reserved	[7:3]	–	–
Data Collision Error Flag (DCOL)	[2]	This flag is set if the SPTDATn is written or the SPRDATn is read while a transfer is in progress and cleared by reading the SPSTAn. 0 = Not detect,                      1 = Collision error detect	0
Multi Master Error Flag (MULF)	[1]	This flag is set if the nSS signal goes to active low while the SPI is configured as a master, and SPPINn's ENMUL bit is multi master errors detect mode. MULF is cleared by reading SPSTAn. 0 = Not detect,                      1 = Multi master error detect	0
Transfer Ready Flag (REDY)	[0]	This bit indicates that SPTDATn or SPRDATn is ready to transmit or receive. This flag is automatically cleared by writing data to SPTDATn. 0 = Not ready,                      1 = Data Tx/Rx ready	1

**SPI PIN CONTROL REGISTER**

When the SPI system is enabled, the direction of pins is controlled by MSTR bit of SPCONn register except nSS pin. The direction of nSS pin is input always.

When the SPI is a master, nSS pin is used to check multi-master error, provided the SPPIN's ENMUL bit is active, and another GPIO should be used to select a slave.

If the SPI is configured as a slave, nSS pin is used to select SPI as a slave by one master.

Register	Address	R/W	Description	Reset Value
SPPIN0	0x44500008	R/W	SPI Channel 0 Pin Control Register	0x02
SPPIN1	0x44500028	R/W	SPI Channel 1 Pin Control Register	0x02

SPPINn	Bit	Description	Initial State
Reserved	[7:3]	–	–
Multi Master error detect Enable (ENMUL)	[2]	The /SS pin is used as an input to detect multi master error when the SPI system is a master. 0 = Disable (general purpose), 1 = Multi master error detect enable	0
Reserved	[1]	This bit should be '1'.	1
Master Out Keep (KEEP)	[0]	Determines MOSI drive or release when 1byte transmit finish(only master) 0 = Release,                      1 = Drive the previous level	0

The SPIMISO(MISO) and SPIMOSI(MOSI) data pins are used for transmitting and receiving serial data. When the SPI is configured as a master, SPIMISO(MISO) is the master data input line, SPIMOSI(MOSI) is the master data output line, and SPICLK(SCK) is the clock output line. When as a slave, these pins reverse roles. In a multiple-master system, all SPICLK(SCK) pins are tied together, all SPIMOSI(MOSI) pins are tied together, and all SPIMISO(MISO) pins are tied together.

Only an SPI master can experience a multi master error, caused when a second SPI device becomes a master and selects this device as if it were a slave. When this type error is detected, the following actions are taken immediately. But you must previously set SPPINn's ENMUL bit if you want to detect this error.

1. The SPCONn's MSTR bit is forced to 0 to operate slave mode.
2. The SPSTAn's MULF flag is set, and an SPI interrupt is generated.



## SPI BAUD RATE PRESCALER REGISTER

Register	Address	R/W	Description	Reset Value
SPPRE0	0x4450000C	R/W	SPI channel 0 baud rate prescaler register	0x00
SPPRE1	0x4450002C	R/W	SPI channel 1 baud rate prescaler register	0x00

SPPREn	Bit	Description	Initial State
Prescaler Value	[7:0]	Determines SPI clock rate as above equation. Baud rate = PCLK / 2 / (Prescaler value + 1)	0x00

**NOTE:** Baud rate should be less than 25MHz.

## SPI TX DATA REGISTER

Register	Address	R/W	Description	Reset Value
SPTDAT0	0x44500010	R/W	SPI channel 0 Tx data register	0x00
SPTDAT1	0x44500030	R/W	SPI channel 1 Tx data register	0x00

SPTDATn	Bit	Description	Initial State
Tx Data Register	[7:0]	This field contains the data to be transmitted over the SPI channel	0x00

## SPI RX DATA REGISTER

Register	Address	R/W	Description	Reset Value
SPRDAT0	0x44500014	R	SPI channel 0 Rx data register	0x00
SPRDAT1	0x44500034	R	SPI channel 1 Rx data register	0x00

SPRDATn	Bit	Description	Initial State
Rx Data Register	[7:0]	This field contains the data to be received over the SPI channel	0x00

## NOTES



# 16

## AC97 CONTROLLER

### OVERVIEW

The AC97 Controller Unit of S3C24A0A supports the AC97 revision 2.0 features. AC97 Controller communicates with AC97 Codec using audio controller link (AC-link). Controller sends the stereo PCM data to Codec. The external digital-to-analog converter (DAC) in the Codec then converts the audio sample to an analog audio waveform. Also, Controller receives the stereo PCM data and the mono MIC data from Codec then store in memories. This chapter describes the programming model for the AC97 Controller Unit. The information in this chapter requires an understanding of the AC97 revision 2.0 specification.

### FEATURE

- Independent channels for stereo PCM In, stereo PCM Out, mono MIC In.
- 32bit (16-bit x 2), 16 entries for stereo PCM In, stereo PCM Out and 16bit, 16 entries for MIC In.
- All of the channels support only 16-bit sample lengths.
- Variable sampling rate AC97 Codec interface (48kHz and below)
- DMA-based operation and interrupt based operation.
- Only primary Codec support.

## AC97 CONTROLLER OPERATION

### BLOCK DIAGRAM

Figure 16-1 shows the functional block diagram of S3C24A0A AC97 Controller. The AC97 signals form the AC-link, which is a point-to-point synchronous serial interconnection that supports full-duplex data transfers. All digital audio streams and command/status information are communicated over the AC-link.

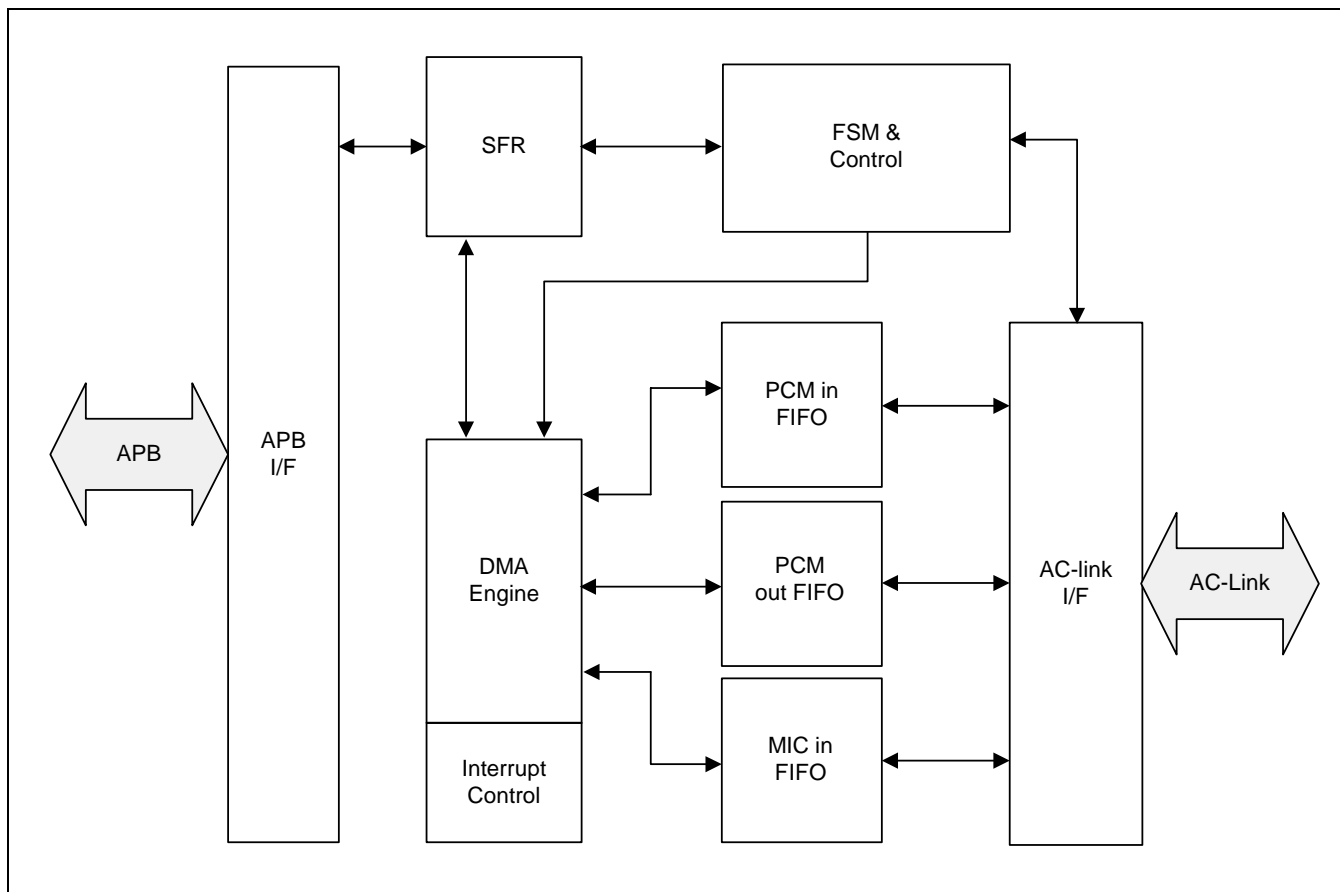
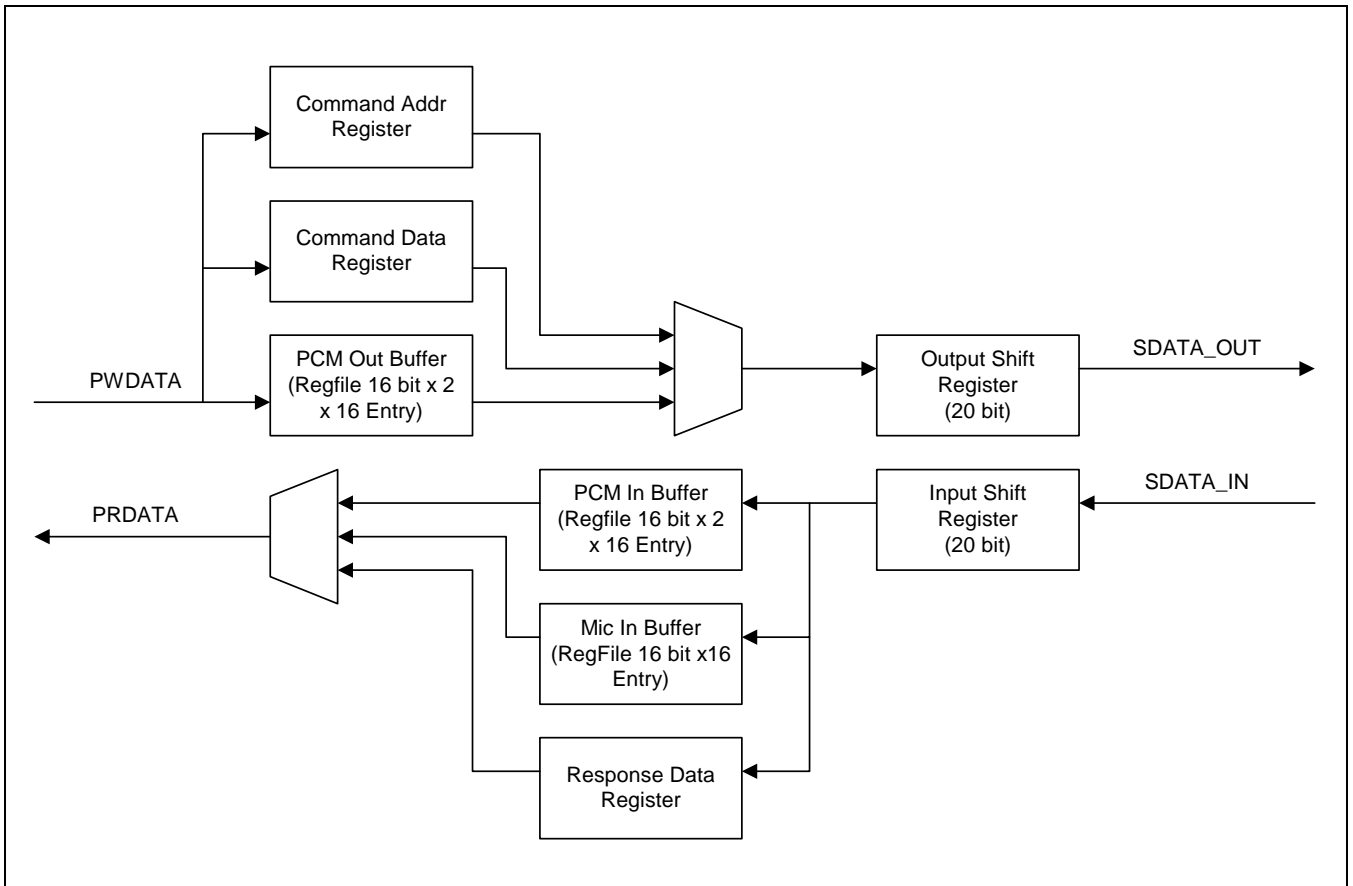

Figure 16-1. AC97 Block Diagram

**INTERNAL DATA PATH**

Figure 16-2 shows the internal data path of S3C24A0A AC97 Controller. It has stereo Pulse Code Modulated (PCM) In, Stereo PCM Out and mono MIC-in buffers, which consist of 16-bit, 16 entries buffer. Also it has 20-bit I/O shift register via AC-link.



**Figure 16-2. Internal Data Path**

## OPERATION FLOW CHART

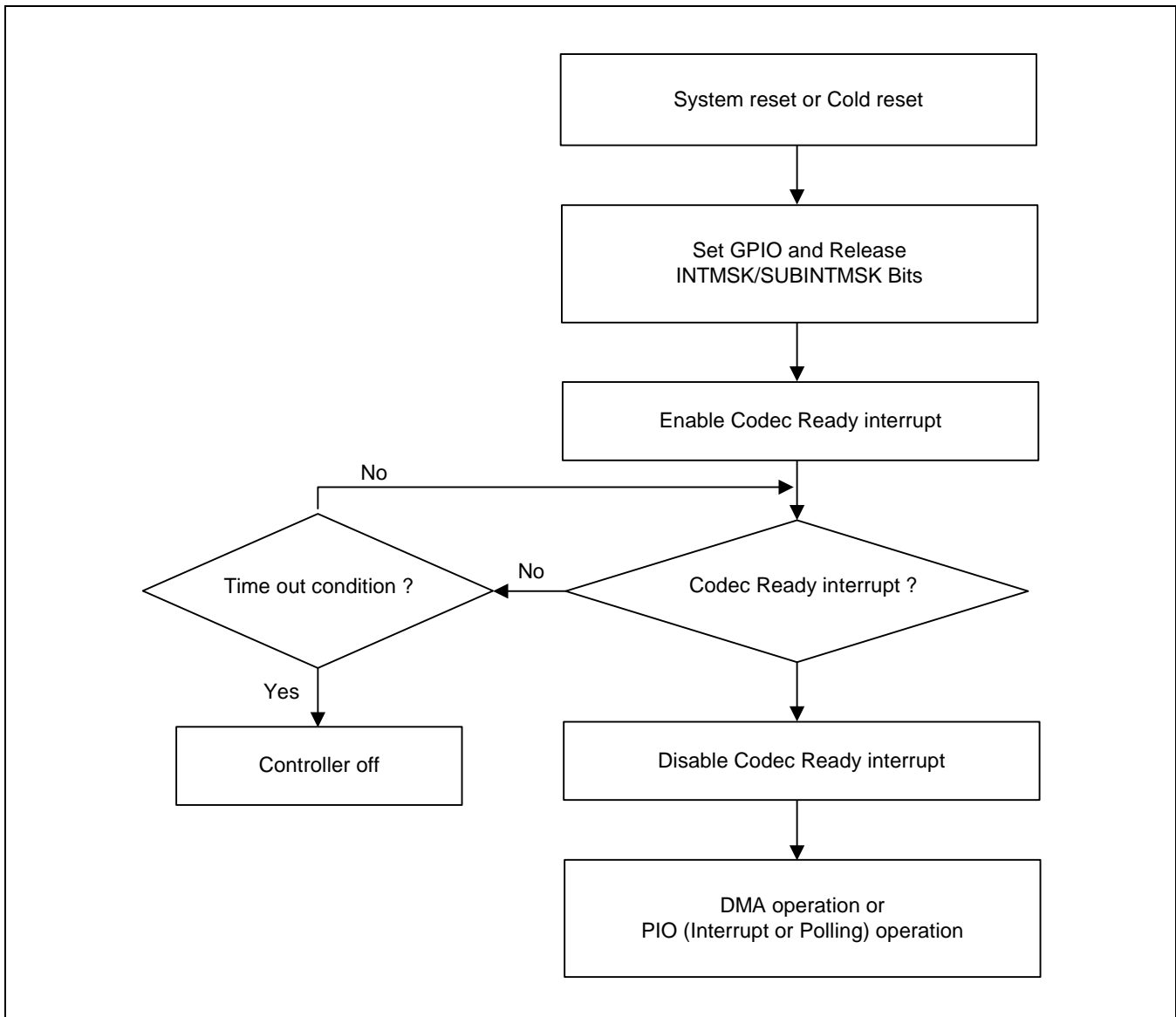
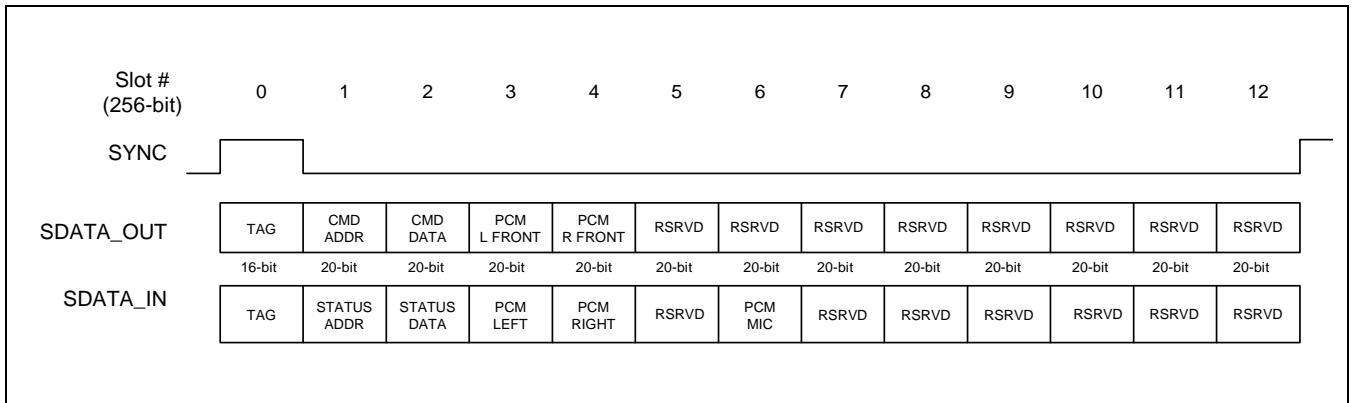

Figure 16-3. AC97 Operation Flow Chart



### AC-LINK DIGITAL INTERFACE PROTOCOL

Each AC97 Codec incorporates a five-pin digital serial interface that links it to the S3C24A0A AC97 Controller. AC-link is a full-duplex, fixed-clock, PCM digital stream. It employs a time division multiplexed (TDM) scheme to handle control register accesses and multiple input and output audio streams. The AC-link architecture divides each audio frame into 12 outgoing and 12 incoming data streams. Each stream has 20-bit sample resolution and requires a DAC and an analog-to-digital converter (ADC) with a minimum 16-bit resolution.



**Figure 16-4. Bi-directional AC-link Frame with Slot Assignments**

Figure 28-4 shows Tag and Data Phase organization for the controller and the Codec. The figure also lists the slot definitions that the S3C24A0A AC97 Controller supports. The S3C24A0A AC97 Controller provides synchronization for all data transaction on the AC-link.

A data transaction is made up of 256 bits of information broken up into groups of 13 time slots and is called a frame. Time slot 0 is called the Tag Phase and is 16 bits long. The other 12 time slots are called the Data Phase. The Tag Phase contains one bit that identifies a valid frame and 12 bits that identify the time slots in the Data Phase that contain valid data. Each time slot in the Data Phase is 20 bits long. A frame begins when SYNC goes high. The amount of time that SYNC is high corresponds to the Tag Phase. AC97 frames occur at fixed 48 kHz intervals and are synchronous to the 12.288 MHz bit rate clock, BITCLK. The controller and the Codec use the SYNC and BITCLK to determine when to send transmit data and when to sample received data. A transmitter transitions the serial data stream on each rising edge of BITCLK and a receiver samples the serial data stream on falling edges of BITCLK. The transmitter must tag the valid slots in its serial data stream. The valid slots are tagged in slot 0. Serial data on the AC-link is ordered most significant bit (MSB) to least significant bit (LSB). The Tag Phase's first bit is bit 15 and the first bit of each slot in Data Phase is bit 19. The last bit in any slot is bit 0.

AC-LINK OUTPUT FRAME (SDATA\_OUT)

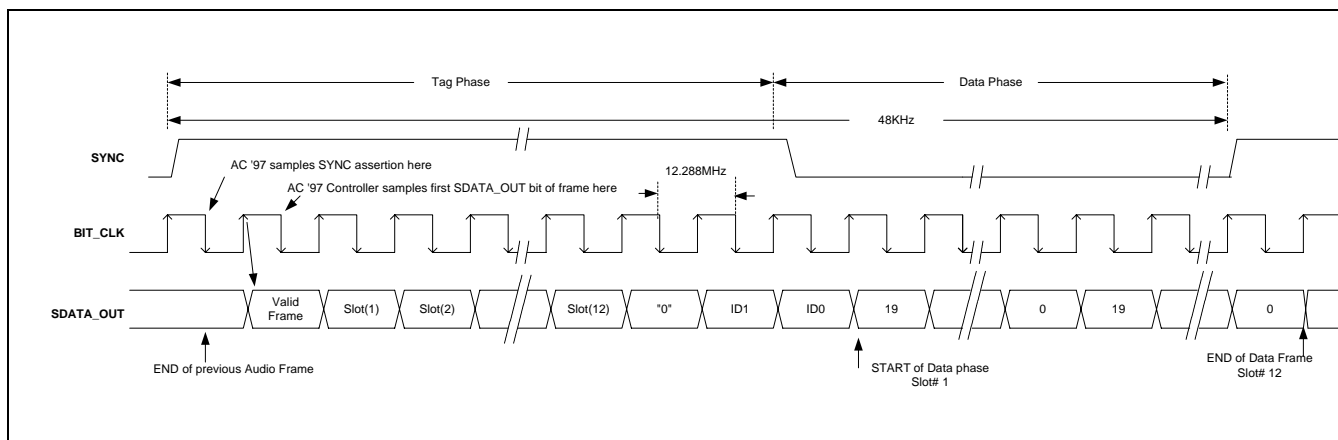

Figure 16-5. AC-link Output Frame

AC-LINK INPUT FRAME (SDATA\_IN)

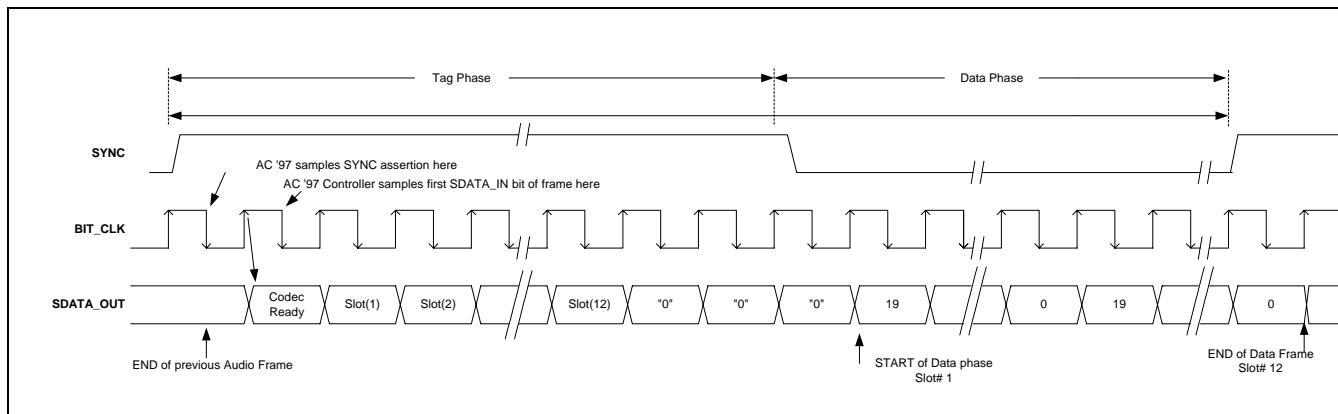

Figure 16-6. AC-link Input Frame

## AC97 POWERDOWN

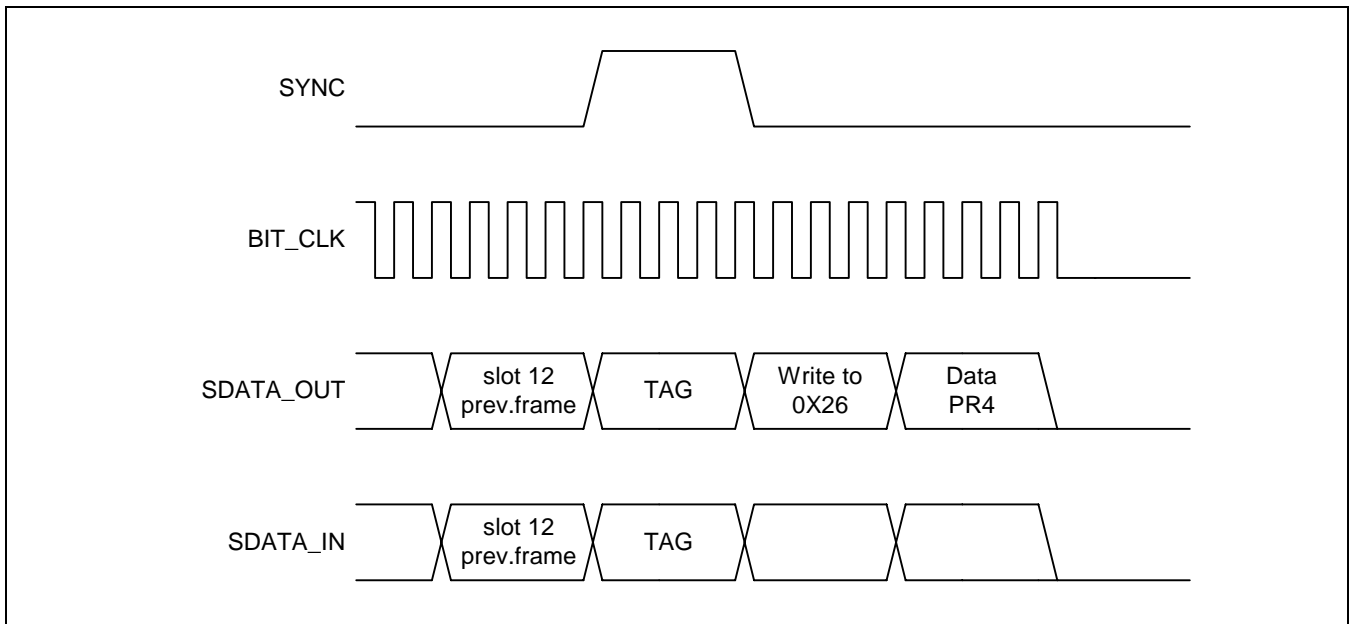

Figure 16-7. AC97 Powerdown Timing

### Powering Down the AC-link

The AC-link signals enter a low power mode when the AC97 Codec Powerdown register (0x26) bit PR4 is set to a 1 (by writing 0x1000). Then the Primary Codec drives both BITCLK and SDATA\_IN to a logic low voltage level. The sequence follows the timing diagram shown in Figure 16-7.

The AC97 Controller transmits the write to Powerdown register (0x26) over the AC-link. Set up the AC97 Controller so that it does not transmit data to slots 3-12 when it writes to the Powerdown register bit PR4 (data 0x1000), and it does not require the Codec to process other data when it receives a power down request. When the Codec processes the request it immediately transitions BITCLK and SDATA\_IN to a logic low level. The AC97 Controller drives SYNC and SDATA\_OUT to a logic low level after programming the AC\_GLBCTRL register.

### Waking up the AC-link - Wake Up Triggered by the AC97 Controller

AC-link protocol provides for a cold AC97 reset and a warm AC97 reset. The current power-down state ultimately dictates which AC97 reset is used. Registers must stay in the same state during all power-down modes unless a cold AC97 reset is performed. In a cold AC97 reset, the AC97 registers are initialized to their default values. After a power down, the AC-link must wait for a minimum of four audio frame times after the frame in which the power down occurred before it can be reactivated by reasserting the SYNC signal. When AC-link powers up, it indicates readiness through the Codec ready bit (input slot 0, bit 15).

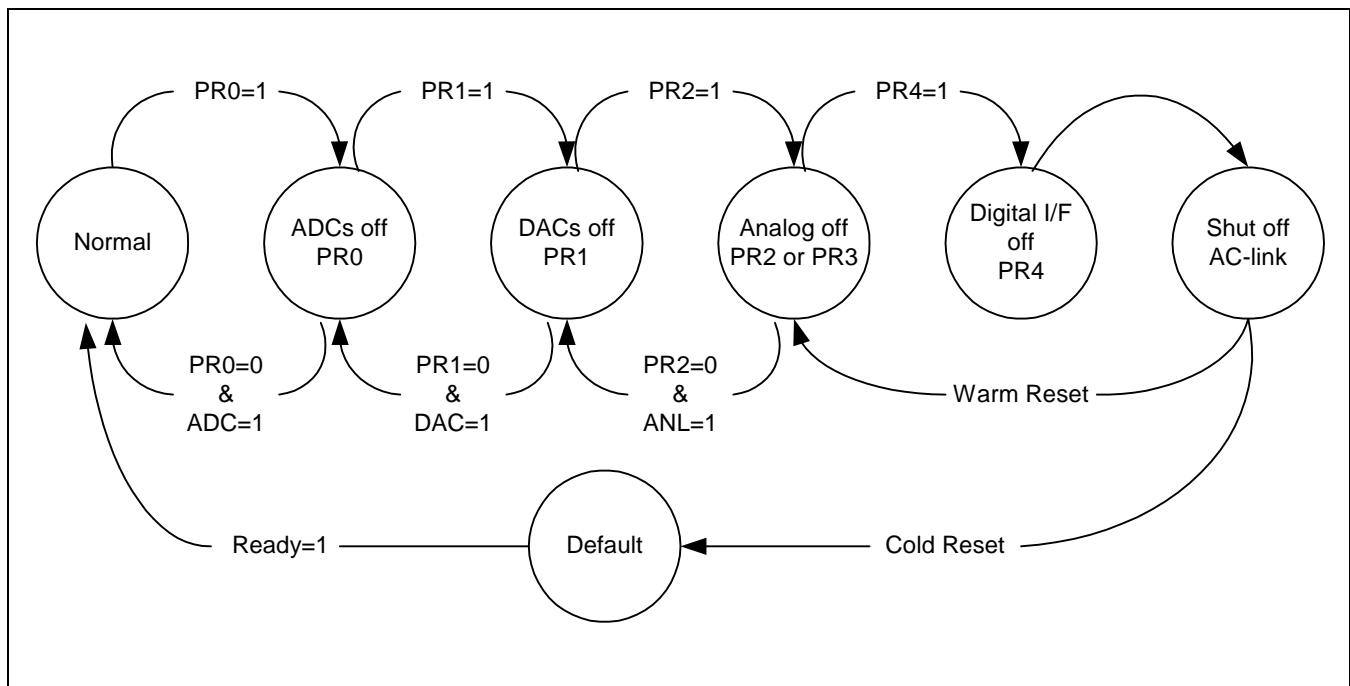

Figure 16-8. AC97 Power down/Power up Flow

#### Cold AC97 Reset

A cold reset is generated when the nRESET pin is asserted through the AC\_GLBCTRL. Asserting and deasserting nRESET activates BITCLK and SDATA\_OUT. All AC97 control registers are initialized to their default power on reset values. nRESET is an asynchronous AC97 input.

#### Warm AC97 Reset

A warm AC97 reset reactivates the AC-link without altering the current AC97 register values. A warm reset is generated when BITCLK is absent and SYNC is driven high. In normal audio frames, SYNC is a synchronous AC97 input. When BITCLK is absent, SYNC is treated as an asynchronous input used to generate a warm reset to AC97. The AC97 Controller must not activate BITCLK until it samples SYNC low again. This prevents a new audio frame from being falsely detected; When the AC97 Controller receives a wake-up from the Codec.

## AC97 CONTROLLER SPECIAL REGISTERS

### AC97 GLOBAL CONTROL REGISTER (AC\_GLBCTRL)

Register	Address	R/W	Description	Reset Value
AC_GLBCTRL	0x45000000	R/W	AC97 global control register	0x000000

AC_GLBCTRL	Bit	Description	Initial State
Reserved	[31:23]	Reserved	0x00
Codec ready interrupt enable	[22]	0 = Disable 1 = Enable	0
PCM out channel underrun interrupt enable	[21]	0 = Disable 1 = Enable ( FIFO is empty)	0
PCM in channel overrun interrupt enable	[20]	0 = Disable 1 = Enable ( FIFO is full)	0
MIC in channel overrun interrupt enable	[19]	0 = Disable 1 = Enable ( FIFO is full)	0
PCM out channel threshold interrupt enable	[18]	0 = Disable 1 = Enable ( FIFO is half empty)	0
PCM in channel threshold interrupt enable	[17]	0 = Disable 1 = Enable ( FIFO is half full)	0
MIC in channel threshold interrupt enable	[16]	0 = Disable 1 = Enable ( FIFO is half full)	0
Reserved	[15:14]	Reserved	00
PCM out channel transfer mode	[13:12]	00 = Off 01 = PIO 10 = DMA 11 = Reserved	00
PCM in channel transfer mode	[11:10]	00 = Off 01 = PIO 10 = DMA 11 = Reserved	00
MIC in channel transfer mode	[9:8]	00 = Off 01 = PIO 10 = DMA 11 = Reserved	00
Reserved	[7:4]	Reserved	0000
Transfer data enable using AC-link	[3]	0 = Disable 1 = Enable	0
AC-link on	[2]	0 = Off 1 = SYNC signal transfer to Codec	0
Warm reset	[1]	0 = Normal 1 = Wake up codec from power down	0
Cold reset	[0]	0 = Normal 1 = Reset Codec and Controller logic	0



**AC97 GLOBAL STATUS REGISTER (AC\_GLBSTAT)**

Register	Address	R/W	Description	Reset Value
AC_GLBSTAT	0x45000004	R	AC97 global status register	0x00000000

AC_GLBSTAT	Bit	Description	Initial State
Reserved	[31:23]	Reserved	0x00
Codec ready interrupt	[22]	0 = Not requested      1 = Requested	0
PCM out channel underrun interrupt	[21]	0 = Not requested      1 = Requested	0
PCM in channel overrun interrupt	[20]	0 = Not requested      1 = Requested	0
MIC in channel overrun interrupt	[19]	0 = Not requested      1 = Requested	0
PCM out channel threshold interrupt	[18]	0 = Not requested      1 = Requested	0
PCM in channel threshold interrupt	[17]	0 = Not requested      1 = Requested	0
MIC in channel threshold interrupt	[16]	0 = Not requested      1 = Requested	0
Reserved	[15:3]	Reserved	0x000
Controller main state	[2:0]	000 = Idle      001 = Init      010 = Ready 011 = Active      100 = LP      101 = Warm	000

**AC97 CODEC COMMAND REGISTER (AC\_CODEC\_CMD)**

Register	Address	R/W	Description	Reset Value
AC_CODEC_CMD	0x45000008	R/W	AC97 codec command register	0x00000000

AC_CODEC_CMD	Bit	Description	Initial State
Reserved	[31:24]	Reserved	0x00
Read enable	[23]	0 = Command write 1 = Status read	0
Address	[22:16]	Codec command address	0x00
Data	[15:0]	Codec command data	0x0000

**AC97 CODEC STATUS REGISTER (AC\_CODEC\_STAT)**

Register	Address	R/W	Description	Reset Value
AC_CODEC_STAT	0x4500000C	R	AC97 codec status register	0x00000000

AC_CODEC_STAT	Bit	Description	Initial State
Reserved	[31:23]	Reserved	0x00
Address	[22:16]	Codec status address	0x00
Data	[15:0]	Codec status data	0x0000

**AC97 PCM OUT/IN CHANNEL FIFO ADDRESS REGISTER (AC\_PCMADDR)**

Register	Address	R/W	Description	Reset Value
AC_PCMADDR	0x45000010	R	AC97 PCM Out/In channel FIFO address register	0x00000000

AC_PCMADDR	Bit	Description	Initial State
Reserved	[31:28]	Reserved	0000
Out read address	[27:24]	PCM out channel FIFO read address	0000
Reserved	[23:20]	Reserved	0000
In read address	[19:16]	PCM in channel FIFO read address	0000
Reserved	[15:12]	Reserved	0000
Out write address	[11:8]	PCM out channel FIFO write address	0000
Reserved	[7:4]	Reserved	0000
In write address	[3:0]	PCM in channel FIFO write address	0000



**AC97 MIC IN CHANNEL FIFO ADDRESS REGISTER (AC\_MICADDR)**

Register	Address	R/W	Description	Reset Value
AC_MICADDR	0x45000014	R	AC97 MIC In channel FIFO address register	0x00000000

AC_MICADDR	Bit	Description	Initial State
Reserved	[31:20]	Reserved.	0000
Read address	[19:16]	MIC in channel FIFO read address	0000
Reserved	[15:4]	Reserved.	0x000
Write address	[3:0]	MIC in channel FIFO write address	0000

**AC97 PCM OUT/IN CHANNEL FIFO DATA REGISTER (AC\_PCMDATA)**

Register	Address	R/W	Description	Reset Value
AC_PCMDATA	0x45000018	R/W	AC97 PCM Out/In channel FIFO data register	0x00000000

AC_PCMDATA	Bit	Description	Initial State
Left data	[31:16]	PCM Out/In left channel FIFO data Read = PCM in left channel Write = PCM out left channel	0x0000
Right data	[15:0]	PCM Out/In right channel FIFO data Read = PCM in right channel Write = PCM out right channel	0x0000

**AC97 MIC IN CHANNEL FIFO DATA REGISTER (AC\_MICDATA)**

Register	Address	R/W	Description	Reset Value
AC_MICDATA	0x4500001C	R/W	AC97 MIC In channel FIFO data register	0x00000000

AC_MICDATA	Bit	Description	Initial State
Reserved	[31:16]	Reserved	0x0000
Mono data	[15:0]	MIC in mono channel FIFO data	0x0000



# 17

## USB HOST CONTROLLER

### OVERVIEW

S3C24A0A supports 2 port USB host interface as follows;

- Open HCI Rev 1.0 compatible.
- USB Rev1.1 compatible
- 2 down stream ports.
- Support for both LowSpeed and HighSpeed USB devices

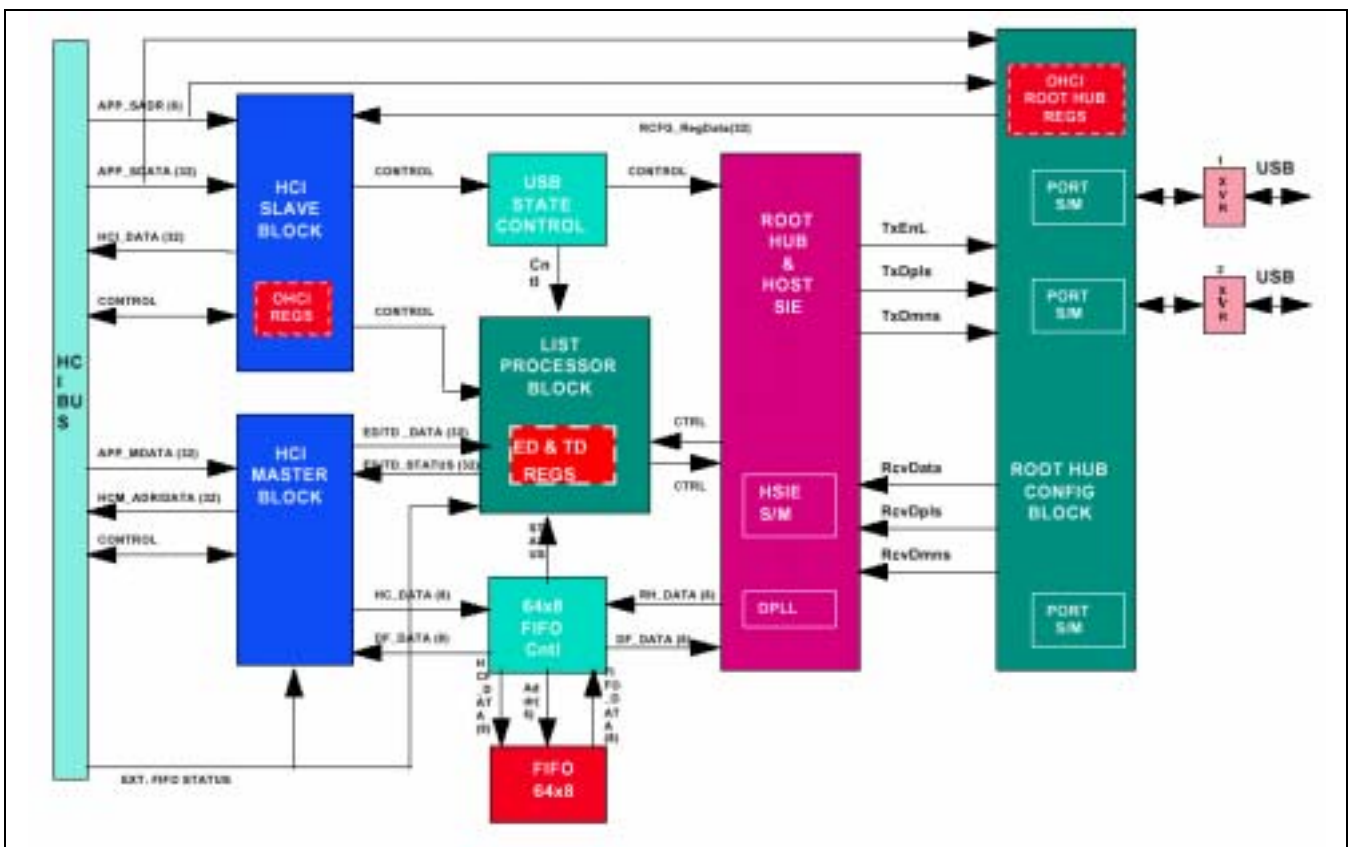

Figure 17-1. USB Host Controller Block Diagram

## USB HOST CONTROLLER SPECIAL REGISTERS

The S3C24A0A USB Host controller complies with OPEN HCI Rev 1.0. Please refer to Open Host Controller Interface Rev 1.0 specification for detail information.

### OHCI REGISTERS FOR USB HOST CONTROLLER

Register	Base Address	R/W	Description	Reset Value
HcRevision	0x41000000	–	Control and status group	–
HcControl	0x41000004	–		–
HcCommonStatus	0x41000008	–		–
HcInterruptStatus	0x4100000c	–		–
HcInterruptEnable	0x41000010	–		–
HcInterruptDisable	0x41000014	–		–
HcHCCA	0x41000018	–	Memory pointer group	–
HcPeriodCuttentED	0x4100001C	–		–
HcControlHeadED	0x41000020	–		–
HcControlCurrentED	0x41000024	–		–
HcBulkHeadED	0x41000028	–		–
HcBulkCurrentED	0x4100002c	–		–
HcDoneHead	0x41000030	–		–
HcRmInterval	0x41000034	–		Frame counter group
HcFmRemaining	0x41000038	–	–	
HcFmNumber	0x4100003c	–	–	
HcPeriodicStart	0x41000040	–	–	
HcLSThreshold	0x41000044	–	–	
HcRhDescriptorA	0x41000048	–	Root hub group	
HcRhDescriptorB	0x4100004C	–		–
HcRhStatus	0x41000050	–		–
HcRhPortStatus1	0x41000054	–		–
HcRhPortStatus2	0x41000058	–		–

# 18

## USB DEVICE

### OVERVIEW

USB device controller is designed to provide a high performance full speed function controller solution with DMA I/F. USB device controller allows bulk transfer with DMA, interrupt transfer and control transfer.

The functions are as follows:

- Full speed USB device controller compatible with the USB specification version 1.1
- DMA interface for bulk transfer
- 5 endpoints with FIFO
  - EP0: 16byte (Register)
  - EP1: 128byte IN/OUT FIFO (dual port asynchronous RAM): interrupt or DMA
  - EP2: 128byte IN/OUT FIFO (dual port asynchronous RAM): interrupt or DMA
  - EP3: 128byte IN/OUT FIFO (dual port asynchronous RAM): interrupt or DMA
  - EP4: 128byte IN/OUT FIFO (dual port asynchronous RAM): interrupt or DMA
- Integrated USB Transceiver

### FEATURE

- Fully compliant with USB Specification Version 1.1
- Full speed (12Mbps) device
- Integrated USB Transceiver
- Supports control, interrupt and bulk transfer
- 5 endpoints with FIFO:
  - One bi-directional control Endpoint with 16-byte FIFO (EP0)
  - Four bi-directional bulk endpoint with 128-byte FIFO (EP1, EP2, EP3, EP4)
- Supports DMA interface for receive and transmit bulk endpoints. (EP1, EP2, EP3, EP4)
- Independent 128byte receive and transmit FIFO to maximize throughput
- Supports suspend and remote wake-up function



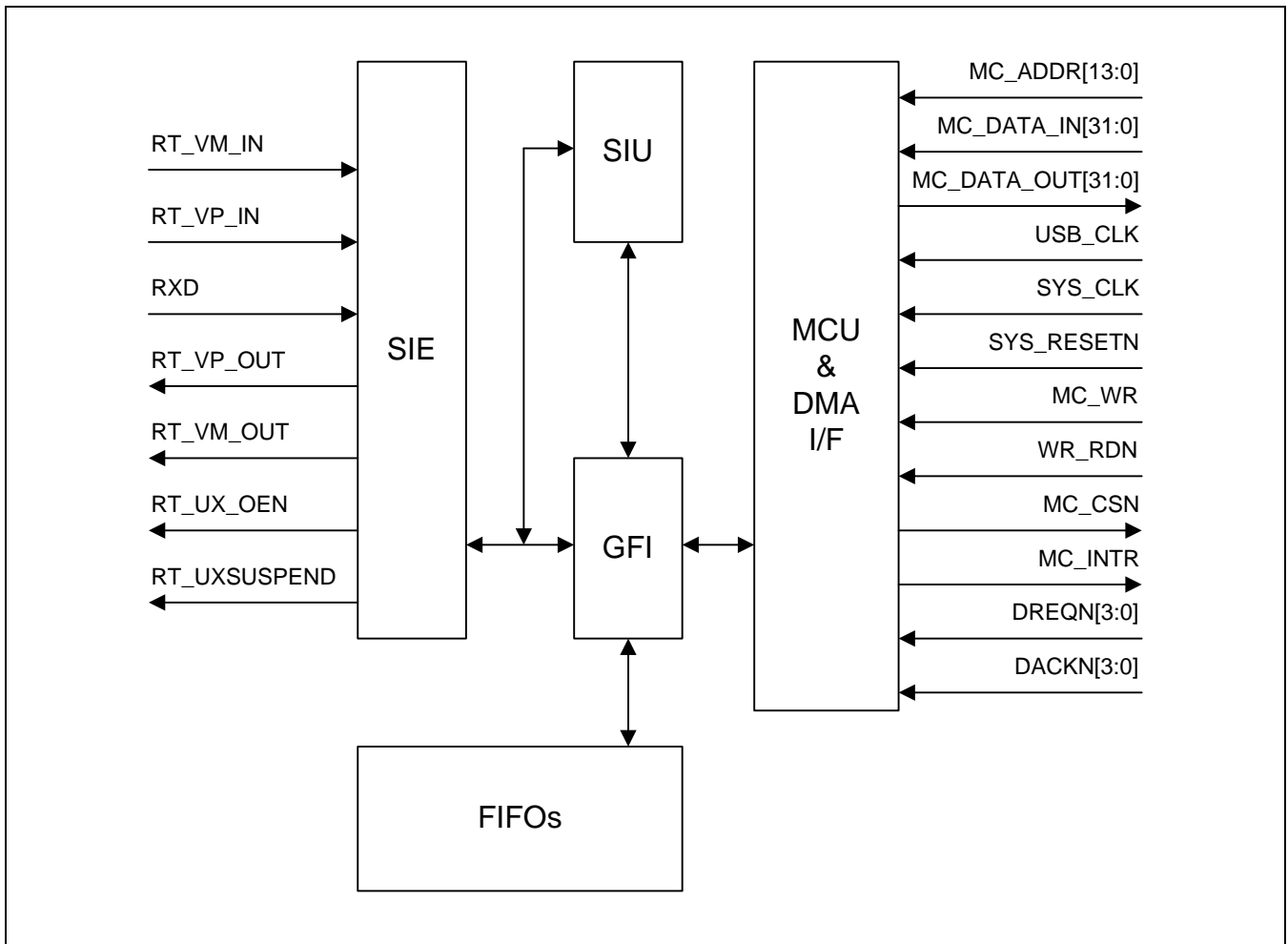

Figure 18-1. USB Device Block Diagram

## USB DEVICE SPECIAL REGISTERS

This section describes the detail functionality about register set USB Device. All special function register is byte access or word access. All reserved bit is zero. Common indexed registers depend on INDEX\_REG(offset address : 0X178) value. For example if you want to write EP0 CSR register, you must write '0x00' on INDEX\_REG before writing IN CSR1 register.

All Register must be resettled after Host Reset Signaling.

Register Name	Description	Offset Address
<b>Non Indexed Registers</b>		
FUNC_ADDR_REG	Function address register	0x140
PWR_REG	Power management register	0x144
EP_INT_REG (EP0–EP4)	Endpoint interrupt register	0x148
USB_INT_REG	USB interrupt register	0x158
EP_INT_EN_REG (EP0–EP4)	Endpoint interrupt enable register	0x15C
USB_INT_EN_REG	USB Interrupt enable register	0x16C
FRAME_NUM1_REG	Frame number 1 register	0x170
FRAME_NUM2_REG	Frame number 2 register	0x174
INDEX_REG	Index register	0x178
EP0_FIFO_REG	Endpoint0 FIFO register	0x1C0
EP1_FIFO_REG	Endpoint1 FIFO register	0x1C4
EP2_FIFO_REG	Endpoint2 FIFO register	0x1C8
EP3_FIFO_REG	Endpoint3 FIFO register	0x1CC
EP4_FIFO_REG	Endpoint4 FIFO register	0x1D0
EP1_DMA_CON	Endpoint1 DMA control register	0x200
EP1_DMA_UNIT	Endpoint1 DMA Unit counter register	0x204
EP1_DMA_FIFO	Endpoint1 DMA FIFO counter register	0x208
EP1_DMA_TTC_L	Endpoint1 DMA Transfer counter low-byte register	0x20C
EP1_DMA_TTC_M	Endpoint1 DMA Transfer counter middle-byte register	0x210
EP1_DMA_TTC_H	Endpoint1 DMA Transfer counter high-byte register	0x214

**USB DEVICE SPECIAL REGISTERS (Continued)**

Register Name	Description	Offset Address
EP2_DMA_CON	Endpoint2 DMA control register	0x218
EP2_DMA_UNIT	Endpoint2 DMA unit counter register	0x21C
EP2_DMA_FIFO	Endpoint2 DMA FIFO counter register	0x220
EP2_DMA_TTC_L	Endpoint2 DMA transfer counter low-byte register	0x224
EP2_DMA_TTC_M	Endpoint2 DMA transfer counter middle-byte register	0x228
EP2_DMA_TTC_H	Endpoint2 DMA transfer counter high-byte register	0x22C
EP3_DMA_CON	Endpoint3 DMA control register	0x240
EP3_DMA_UNIT	Endpoint3 DMA unit counter register	0x244
EP3_DMA_FIFO	Endpoint3 DMA FIFO counter register	0x248
EP3_DMA_TTC_L	Endpoint3 DMA transfer counter low-byte register	0x24C
EP3_DMA_TTC_M	Endpoint3 DMA transfer counter middle-byte register	0x250
EP3_DMA_TTC_H	Endpoint3 DMA transfer counter high-byte register	0x254
EP4_DMA_CON	Endpoint4 DMA control register	0x258
EP4_DMA_UNIT	Endpoint4 DMA unit counter register	0x25C
EP4_DMA_FIFO	Endpoint4 DMA FIFO counter register	0x260
EP4_DMA_TTC_L	Endpoint4 DMA transfer counter low-byte register	0x264
EP4_DMA_TTC_M	Endpoint4 DMA transfer counter middle-byte register	0x268
EP4_DMA_TTC_H	Endpoint4 DMA transfer counter high-byte register	0x26C
<b>Common Indexed Registers</b>		
MAXP_REG	Endpoint MAX packet register	0x180
<b>In Indexed Registers</b>		
IN_CSR1_REG	EP In control status register 1	0x184
IN_CSR2_REG	EP In control status register 2	0x188
<b>Out Indexed Registers</b>		
OUT_CSR1_REG	EP Out control status register 1	0x190
OUT_CSR2_REG	EP Out control status register 2	0x194
OUT_FIFO_CNT1_REG	EP Out write count register 1	0x198
OUT_FIFO_CNT2_REG	EP Out write count register 2	0x19C

**FUNC\_ADDR\_REG**

This register maintains the USB Device Address assigned by the host. The MCU writes the value received through a SET\_ADDRESS descriptor to this register. This address is used for the next token.

Register	Address	R/W	Description	Reset Value
FUNC_ADDR_REG	0x44A00140	R/W (byte)	Function address register	0x00

FUNC_ADDR_REG	Bit	MCU	USB	Description	Initial State
ADDR_UPDATE	[7]	R/W	R /CLEAR	The MCU sets this bit whenever it updates the FUNCTION_ADDR field in this register. This bit will be cleared by USB when DATA_END bit in EP0_CSR register.	0
FUNCTION_ADDR	[6:0]	R/W	R	The MCU write the unique address, assigned by host, to this field.	00

**POWER MANAGEMENT REGISTER (PWR\_REG)**

This register is power control register in USB block.

Register	Address	R/W	Description	Reset Value
PWR_REG	0x44A00144	R/W (byte)	Power management register	0x00

FUNC_ADDR	Bit	MCU	USB	Description	Initial State
Reserved	[31:9]			Reserved	0
ISO_UPDATE	[7]	R/W	R	Used for ISO mode only. If set, GFI waits for a SOF token to set IN_PKT_RDY even though a packet to send is already loaded by MCU. If an IN token is received before a SOF token, then a zero length data packet will be sent.	0
Reserved	[6:4]	–	–	Reserved	–
USB_RESET	[3]	R	SET	The USB sets this bit if reset signaling is received from the host. This bit remains set as long as reset signaling persists on the bus	0
MCU_RESUME	[2]	R/W	R /CLEAR	The MCU sets this bit for MCU resume. The USB generates the resume signaling depending RESUME CON Register, while this bit is set in suspend mode.	
SUSPEND_MODE	[1]	R	SET /CLEAR	This bit can be set by USB, automatically when the device enter into suspend mode. It is cleared under the following conditions 1) The MCU clears the MCU_RESUME bit by writing '0', to end remote resume signaling. 2) The resume signal form host is received.	0
SUSPEND_EN	[0]	R/W	R	Suspend mode enable control bit 0 = Disable(default). The device will not enter suspend mode. 1 = Enable suspend mode	0



**INTERRUPT REGISTER (EP\_INT\_REG, USB\_INT\_REG)**

The USB core has two interrupt registers.

These registers act as status registers for the MCU when it is interrupted. The bits are cleared by writing a '1'(not '0') to each bit that was set.

Once the MCU is interrupted, MCU should read the contents of interrupt-related registers and write back to clear the contents if it is necessary.

Register	Address	R/W	Description	Reset Value
EP_INT_REG	0x44A00148	R/W (byte)	EP Interrupt pending/clear register	0x00

EP_INT_REG	Bit	MCU	USB	Description	Initial State
EP1~EP4 Interrupt	[4:1]	R /CLEAR	SET	<p><b>For BULK/INTERRUPT IN endpoints:</b> The USB sets this bit under the following conditions:</p> <ol style="list-style-type: none"> <li>1. IN_PKT_RDY bit is cleared.</li> <li>2. FIFO is flushed</li> <li>3. SENT_STALL set.</li> </ol> <p><b>For BULK/INTERRUPT OUT endpoints:</b> USB sets this bit under the following conditions:</p> <ol style="list-style-type: none"> <li>1. Sets OUT_PKT_RDY bit</li> <li>2. Sets SENT_STALL bit</li> </ol> <p><b>For ISO IN endpoints:</b> the USB sets this bit under the following conditions:</p> <ol style="list-style-type: none"> <li>1. UNDER_RUN bit is set</li> <li>2. IN_PKT_RDY bit is cleared.</li> <li>3. FIFO is flushed</li> </ol> <p>Note: conditions 1 and 2 are mutually exclusive</p> <p><b>For ISO OUT endpoints:</b> USB sets this bit under the following conditions:</p> <ol style="list-style-type: none"> <li>1. OUT_PKT_RDY bit is set</li> <li>2. OVER RUN bit is set.</li> </ol> <p><b>Note:</b> Conditions 1 and 2 are mutually exclusive.</p>	0
EPO Interrupt	[0]	R /CLEAR	SET	<p>This bit corresponds to endpoint 0 interrupt The USB sets this bit under the following conditions:</p> <ol style="list-style-type: none"> <li>1. OUT_PKT_RDY bit is set.</li> <li>2. IN_PKT_RDY bit is cleared.</li> <li>3. SENT_STALL bit is set</li> <li>4. SETUP_END bit is set</li> <li>5. DATA_END bit is cleared(Indicates end of control transfer)</li> </ol>	0





Register	Address	R/W	Description	Reset Value
USB_INT_REG	0x44A00158	R/W (byte)	USB Interrupt pending/clear register	0x00

USB_INT_REG	Bit	MCU	USB	Description	Initial State
RESET Interrupt	[2]	R /CLEAR	SET	The USB set this bit, when it receives reset signaling.	0
RESUME Interrupt	[1]	R /CLEAR	SET	The USB sets this bit, when it receives resume signaling, <i>while_in suspend mode</i> . If the resume is due to a USB reset, then the MCU is first interrupted with a RESUME interrupt. Once the clocks resume and the SE0 condition persists for 3ms, USB RESET interrupt will be asserted.	0
SUSPEND Interrupt	[0]	R /CLEAR	SET	The USB sets this bit when it receives suspend signaling. This bit is set whenever there is no activity for 3ms on the bus. Thus, if the MCU does not stop the clock after the first suspend interrupt, it will be continue to be interrupted every 3ms as long as there is no activity on the USB bus. By default this interrupt is disabled.	0

**INTERRUPT ENABLE REGISTER (EP\_INT\_EN\_REG, USB\_INT\_REG)**

Corresponding to each interrupt register, there is an INTERRUPT ENABLE register (except resume interrupt enable). By default usb reset interrupt is enabled.

If bit = 0, the interrupt is disabled

If bit = 1, the interrupt is enabled

Register	Address	R/W	Description	Reset Value
EP_INT_EN_REG	0x44A0015C	R/W (byte)	Determines which interrupt is enabled.	0xFF

INT_MASK_REG	Bit	MCU	USB	Description	Initial State
EP4_INT_EN	[4]	R/W	R	EP4 interrupt enable bit 0 = Interrupt disable      1 = Enable	1
EP3_INT_EN	[3]	R/W	R	EP3 interrupt enable bit 0 = Interrupt disable      1 = Enable	1
EP2_INT_EN	[2]	R/W	R	EP2 interrupt enable bit 0 = Interrupt disable      1 = Enable	1
EP1_INT_EN	[1]	R/W	R	EP1 interrupt enable bit 0 = Interrupt disable      1 = Enable	1
EP0_INT_EN	[0]	R/W	R	EP0 interrupt enable bit 0 = Interrupt disable      1 = Enable	1

Register	Address	R/W	Description	Reset Value
USB_INT_EN_REG	0x44A0016C	R/W (byte)	Determines which interrupt is enabled.	0x04

INT_MASK_REG	Bit	MCU	USB	Description	Initial State
RESET_INT_EN	[2]	R/W	R	Reset interrupt enable bit 0 = Interrupt disable      1 = Enable	1
Reserved	[1]	–	–	–	0
SUSPEND_INT_EN	[0]	R/W	R	Suspend interrupt enable bit 0 = Interrupt disable      1 = Enable	0

**FRAME NUMBER REGISTER (FRAME\_NUM1\_REG, FRAME\_NUM2\_REG)**

When host transfer USB packet, there is frame number in SOF(Start Of Frame). The USB catch this frame number and load it into this register, automatically.

Register	Address	R/W	Description	Reset Value
FRAME_NUM1_REG	0x44A00170	R (byte)	Frame number lower byte register	0x00

FRAME_NUM_REG	Bit	MCU	USB	Description	Initial State
FRAME_NUM1	[7:0]	R	W	Frame number lower byte value	00

Register	Address	R/W	Description	Reset Value
FRAME_NUM2_REG	0x44A00174	R (byte)	Frame number higher byte register	0x00

FRAME_NUM_REG	Bit	MCU	USB	Description	Initial State
FRAME_NUM2	[7:0]	R	W	Frame number higher byte value	00

**INDEX REGISTER (INDEX\_REG)**

This INDEX register is used to indicate certain endpoint registers effectively. MCU can access the endpoint registers (MAXP\_REG, IN\_CSR1\_REG, IN\_CSR2\_REG, OUT\_CSR1\_REG, OUT\_CSR2\_REG, OUT\_FIFO\_CNT1\_REG, OUT\_FIFO\_CNT2\_REG) for an endpoint inside the core using the INDEX register.

Register	Address	R/W	Description	Reset Value
INDEX_REG	0x44A00178	R/W (byte)	Register index register	0x00

INDEX_REG	Bit	MCU	USB	Description	Initial State
INDEX	[7:0]	R/W	R	It indicates a certain endpoint.	00

**END POINT0 CONTROL STATUS REGISTER (EP0\_CSR)**

This register has the control and status bits for Endpoint 0. Since a control transaction involves both IN and OUT tokens, there is only one CSR register, mapped to the IN CSR1 register.

(share IN1\_CSR and can access by writing index register "0" and read/write IN1\_CSR)

Register	Address	R/W	Description	Reset Value
EP0_CSR	0x44A00184	R/W (byte)	Endpoint 0 status register	0x00

EP0_CSR	Bit	MCU	USB	Description	Initial State
SERVICED_SETUP_END	[7]	W	CLEAR	The MCU should write a "1" to this bit to clear SETUP_END	0
SERVICED_OUT_PKT_RDY	[6]	W	CLEAR	The MCU should write a "1" to this bit to clear OUT_PKT_RDY	0
SEND_STALL	[5]	R/W	CLEAR	MCU should writes a "1" to this bit at the same time it clears OUT_PKT_RDY, if it decodes an invalid token. 0 = Finish the STALL condition 1 = The USB issues a STALL and shake to the current control transfer.	0
SETUP_END	[4]	R	SET	The USB sets this bit when a control transfer ends before DATA_END is set. When the USB sets this bit, an interrupt is generated to the MCU. When such a condition occurs, the USB flushes the FIFO and invalidates MCU access to the FIFO.	0
DATA_END	[3]	SET	CLEAR	The MCU sets this bit below conditions: 1. After loading the last packet of data into the FIFO, at the same time IN_PKT_RDY is set. 2. While it clears OUT_PKT_RDY after unloading the last packet of data. 3. For a zero length data phase.	0
SENT_STALL	[2]	CLEAR	SET	The USB sets this bit if a control transaction is stopped due to a protocol violation. An interrupt is generated when this bit is set. The MCU should write "0" to clear this bit.	0
IN_PKT_RDY	[1]	SET	CLEAR	The MCU sets this bit after writing a packet of data into EP0 FIFO. The USB clears this bit once the packet has been successfully sent to the host. An interrupt is generated when the USB clears this bit, so as the MCU to load the next packet. For a zero length data phase, the MCU sets DATA_END at the same time.	0
OUT_PKT_RDY	[0]	R	SET	The USB sets this bit once a valid token is written to the FIFO. An interrupt is generated when the USB sets this bit. The MCU clears this bit by writing a "1" to the SERVICED_OUT_PKT_RDY bit.	0



## END POINT IN CONTROL STATUS REGISTER (IN\_CSR1\_REG, IN\_CSR2\_REG)

Register	Address	R/W	Description	Reset Value
IN_CSR1_REG	0x44A00184	R/W (byte)	IN END POINT control status register1	0x00

IN_CSR1_REG	Bit	MCU	USB	Description	Initial State
Reserved	[7]	–	–	–	0
CLR_DATA_TOGGLE	[6]	R/W	R/ CLEAR	This bit can be used in Set-up procedure. 0=There are alternation of DATA0 and DATA1 1=The data toggle bit is cleared and PID in packet will maintain DATA0	0
SENT_STALL	[5]	R/ CLEAR	SET	The USB sets this bit when an IN token issues a STALL handshake, after the MCU sets SEND_STALL bit to start STALL handshaking. When the USB issues a STALL handshake, IN_PKT_RDY is cleared	0
SEND_STALL	[4]	W/R	R	0=The MCU clears this bit to finish the STALL condition. 1=The MCU issues a STALL handshake to the USB.	0
FIFO_FLUSH	[3]	W/ CLEAR	CLEAR	The MCU sets this bit if it intends to flush the packet in Input-related FIFO. This bit is cleared by the USB when the FIFO is flushed. The MCU is interrupted when this happens. If a token is in process, the USB waits until the transmission is complete before FIFO flushing. If two packets are loaded into the FIFO, only first packet (The packet is intended to be sent to the host) is flushed, and the corresponding IN_PKT_RDY bit is cleared	0
UNDER_RUN	[2]	R/ CLEAR	Set	<i>Valid For Iso Mode Only</i> The USB sets this bit when in ISO mode, an IN token is received and the IN_PKT_RDY bit is not set. The USB sends a zero length data packet for such conditions, and the next packet that is loaded into the FIFO is flushed. This bit is cleared by writing 0.	0
Reserved	[1]	–	–	–	0
IN_PKT_RDY	[0]	R/SET	CLEAR	The MCU sets this bit, after writing a packet of data into the FIFO. The USB clears this bit once the packet has been successfully sent to the host. An interrupt is generated when the USB clears this bit, so the MCU can load the next packet. While this bit is set, the MCU will not be able to write to the FIFO. If the SEND STALL bit is set by the MCU, this bit cannot be set.	0



Register	Address	R/W	Description	Reset Value
IN_CSR2_REG	0x44A00188	R/W (byte)	IN END POINT control status register2	0x20

IN_CSR1_REG	Bit	MCU	USB	Description	Initial State
AUTO_SET	[7]	R/W	R	If set, whenever the MCU writes MAXP data, IN_PKT_RDY will automatically be set by the core, without any intervention from MCU. If the MCU writes less than MAXP data, then IN_PKT_RDY bit has to be set by the MCU.	0
ISO	[6]	R/W	R	<i>This bit is used only for endpoints whose transfer type is programmable.</i> '1' Configures endpoint to ISO mode '0' Configures endpoint to Bulk mode	0
MODE_IN	[5]	R/W	R	<i>This bit is used only for endpoints whose direction is programmable.</i> '1' Configures endpoint direction as IN '0' Configures endpoint direction as OUT	1
IN_DMA_INT_EN	[4]	R/W	R	This bit determines whether the interrupt should be issued, or not, when the EP1 IN_PKT_RDY condition happens. This is only useful for DMA mode. 0 = Interrupt enable, 1 = Interrupt Disable	0

## END POINT OUT CONTROL STATUS REGISTER(OUT\_CSR1\_REG, OUT\_CSR2\_REG)

Register	Address	R/W	Description	Reset Value
OUT_CSR1_REG	0x44A00190	R/W (byte)	End point out control status register1	0x00

OUT_CSR1_REG	Bit	MCU	USB	Description	Initial State
CLR_DATA_TOGGLE	[7]	R/W	CLEAR	When the MCU writes a 1 to this bit, the data toggle sequence bit is reset to DATA0.	0
SENT_STALL	[6]	CLEAR /R	SET	The USB sets this bit when an OUT token is ended with a STALL handshake. The USB issues a stall handshake to the host if it sends more than MAXP data for the OUT TOKEN.	0
SEND_STALL	[5]	R/W	R	0 : The MCU clears this bit to end the STALL condition handshake, IN PKT RDY is cleared. 1 : The MCU issues a STALL handshake to the USB. The MCU clears this bit to end the STALL condition handshake, IN PKT RDY is cleared.	0
FIFO_FLUSH	[4]	R/W	CLEAR	The MCU write a 1 to flush the FIFO. This bit can be set only when OUT_PKT_RDY (D0) is set. The packet due to be unloaded by the MCU will be flushed.	0
DATA_ERROR	[3]	R	R/W	<i>This bit is valid only in ISO mode.</i> This bit should be sampled with OUT_PKT_RDY . When set, it indicates the data packet due to be unloaded by the MCU has an error (either bit stuffing or CRC). If two packets are loaded into the FIFO, and the second packet has an error, then this bit gets set only after the first packet is unloaded. This bit is automatically cleared when OUT_PKT_RDY gets cleared.	0
OVER_RUN	[2]	R/Clear	R/W	<i>This bit is valid only in ISO mode.</i> This bit is set if the core is not able to load an OUT ISO token into the FIFO. MCU clears this bit by writing 0.	0
Reserved	[1]	–	–	–	0
OUT_PKT_RDY	[0]	R/ CLEAR	SET	The USB sets this bit after it has loaded a packet of data into the FIFO. Once the MCU reads the packet from FIFO, this bit should be cleared by MCU. (Write a "0")	0

Register	Address	R/W	Description	Reset Value
OUT_CSR2_REG	0x44A00194	R/W (byte)	End Point out control status register2	0x00

OUT_CSR2_REG	Bit	MCU	USB	Description	Initial State
AUTO_CLR	[7]	R/W	R	If MCU set, whenever the MCU reads data from the OUT FIFO, OUT_PKT_RDY will automatically be cleared by the logic, without any intervention from MCU.	0
ISO	[6]	R/W	R	This bit determines endpoint transfer type. '0' : Configures endpoint to Bulk mode. '1' : Configures endpoint to ISO mode	0
OUT_DMA_INT_EN	[5]	R/W	R	This bit determines whether the interrupt should be issued, or not. OUT_PKT_RDY condition happens. This is only useful for DMA mode 0 = Interrupt Enable      1 = Interrupt Disable	0

**END POINT FIFO REGISTER (EPn\_FIFO\_REG)**

To access EPn FIFO, the MCU should access EPn\_FIFO\_REG.

Register	Address	R/W	Description	Reset Value
EP0_FIFO	0x44A001C0	R/W (byte)	End Point0 FIFO register	0xXX
EP1_FIFO	0x44A001C4	R/W (byte)	End Point1 FIFO register	0xXX
EP2_FIFO	0x44A001C8	R/W (byte)	End Point2 FIFO register	0xXX
EP3_FIFO	0x44A001CC	R/W (byte)	End Point3 FIFO register	0xXX
EP4_FIFO	0x44A001D0	R/W (byte)	End Point4 FIFO register	0xXX

EPn_FIFO	Bit	MCU	USB	Description	Initial State
FIFO_DATA	[7:0]	R/W	R/W	FIFO data value	0xXX

**MAX PACKET REGISTER (MAXP\_REG)**

Register	Address	R/W	Description	Reset Value
MAXP_REG	0x44A00180	R/W (byte)	End Point MAX packet register	0x01

MAXP_REG	Bit	MCU	USB	Description	Initial State
MAXP	[3:0]	R/W	R	0000 = Reserved 0001 = MAXP = 8 Byte 0010 = MAXP = 16 Byte 0100 = MAXP = 32 Byte 1000 = MAXP = 64 Byte	0001

**END POINT OUT WRITE COUNT REGISTER(OUT\_FIFO\_CNT1\_REG, OUT\_FIFO\_CNT2\_REG)**

These registers maintain the number of bytes in the packet due to be unloaded by the MCU.

Register	Address	R/W	Description	Reset Value
OUT_FIFO_CNT1_REG	0x44A00198	R (byte)	End Point out write count register1	0x00

OUT_FIFO_CNT1_REG	Bit	MCU	USB	Description	Initial State
OUT_CNT_LOW	[7:0]	R	W	Lower byte of write count	00

Register	Address	R/W	Description	Reset Value
OUT_FIFO_CNT2_REG	0x44A0019C	R (byte)	End Point out write count register2	0x00

OUT_FIFO_CNT2_REG	Bit	MCU	USB	Description	Initial State
OUT_CNT_HIGH	[7:0]	R	W	Higher byte of write count	00

**DMA INTERFACE CONTROL REGISTER (EPn\_DMA\_CON)**

Register	Address	R/W	Description	Reset Value
EP1_DMA_CON	0x44A00200	R/W (byte)	EP1 DMA interface control register	0x00
EP2_DMA_CON	0x44A00218	R/W (byte)	EP2 DMA interface control register	0x00
EP3_DMA_CON	0x44A00240	R/W (byte)	EP3 DMA interface control register	0x00
EP4_DMA_CON	0x44A00258	R/W (byte)	EP4 DMA interface control register	0x00

EPn_DMA_CON	Bit	MCU	USB	Description	Initial State
IN_RUN_OB	[7]	R	W	IN DMA Run Observation	0
STATE	[6:4]	R	W	DMA State Monitoring	0
DEMAND_MODE	[3]	R/W	R	DMA Demand mode enable bit '0' = Demand mode disable '1' = Demand mode enable	0
OUT_RUN_OB / OUT_DMA_RUN	[2]	R/W	R/W	This bit function is separated write and read operation Write operation: '0' = Stop '1' = Run Read operation: OUT DMA Run Observation	0
IN_DMA_RUN	[1]	R/W	R	This bit is used to start DMA operation 0 = Stop 1 = Run	0
DMA_MODE_EN	[0]	R/W	R	This bit is used to set DMA mode 0 = Interrupt Mode 1 = DMA Mode	0

**DMA UNIT COUNTER REGISTER (EPN\_DMA\_UNIT)**

This register is valid in demand mode. In case not demand mode, this register value must be set '0x01'

Register	Address	R/W	Description	Reset Value
EP1_DMA_UNIT	0x44A00204	R/W (byte)	EP1 DMA transfer unit counter base register	0x00
EP2_DMA_UNIT	0x44A0021C	R/W (byte)	EP2 DMA transfer unit counter base register	0x00
EP3_DMA_UNIT	0x44A00244	R/W (byte)	EP3 DMA transfer unit counter base register	0x00
EP4_DMA_UNIT	0x44A0025C	R/W (byte)	EP4 DMA transfer unit counter base register	0x00

DMA_UNIT	Bit	MCU	USB	Description	Initial State
EPn_UNIT_CNT	[7:0]	R/W	R	EP DMA transfer unit counter value	0x00

**DMA FIFO COUNTER REGISTER (EPN\_DMA\_FIFO)**

This register has byte size in FIFO to be transferred by DMA. In case OUT\_DMA\_RUN enable, the value in OUT FIFO Write Count Register1 will be loaded in this register automatically. In case of IN DMA Mode, the MCU should set proper value by S/W.

Register	Address	R/W	Description	Reset Value
EP1_DMA_FIFO	0x44A00208	R/W (byte)	EP1 DMA transfer FIFO counter base register	0x00
EP2_DMA_FIFO	0x44A00220	R/W (byte)	EP2 DMA transfer FIFO counter base register	0x00
EP3_DMA_FIFO	0x44A00248	R/W (byte)	EP3 DMA transfer FIFO counter base register	0x00
EP4_DMA_FIFO	0x44A00260	R/W (byte)	EP4 DMA transfer FIFO counter base register	0x00

DMA_FIFO	Bit	MCU	USB	Description	Initial State
EPn_FIFO_CNT	[7:0]	R/W	R	EP DMA transfer FIFO counter value	0x00



**DMA TOTAL TRANSFER COUNTER REGISTER (EPN\_DMA\_TTC\_L, EPN\_DMA\_TTC\_M, EPN\_DMA\_TTC\_H)**

This register should have total number of bytes to be transferred using DMA.(Total 24-bit Counter)

Register	Address	R/W	Description	Reset Value
EP1_DMA_TTC_L	0x44A0020C	R/W (byte)	EP1 DMA total transfer counter (lower byte)	0x00
EP1_DMA_TTC_M	0x44A00210	R/W (byte)	EP1 DMA total transfer counter (middle byte)	0x00
EP1_DMA_TTC_H	0x44A00214	R/W (byte)	EP1 DMA total transfer counter (higher byte)	0x00
EP2_DMA_TTC_L	0x44A00224	R/W (byte)	EP2 DMA total transfer counter (lower byte)	0x00
EP2_DMA_TTC_M	0x44A00228	R/W (byte)	EP2 DMA total transfer counter (middle byte)	0x00
EP2_DMA_TTC_H	0x44A0022C	R/W (byte)	EP2 DMA total transfer counter (higher byte)	0x00
EP3_DMA_TTC_L	0x44A0024C	R/W (byte)	EP3 DMA total transfer counter (lower byte)	0x00
EP3_DMA_TTC_M	0x44A00250	R/W (byte)	EP3 DMA total transfer counter (middle byte)	0x00
EP3_DMA_TTC_H	0x44A00254	R/W (byte)	EP3 DMA total transfer counter (higher byte)	0x00
EP4_DMA_TTC_L	0x44A00264	R/W (byte)	EP4 DMA total transfer counter (lower byte)	0x00
EP4_DMA_TTC_M	0x44A00268	R/W (byte)	EP4 DMA total transfer counter (middle byte)	0x00
EP4_DMA_TTC_H	0x44A0026C	R/W (byte)	EP4 DMA total transfer counter (higher byte)	0x00

DMA_TX	Bit	MCU	USB	Description	Initial State
EPn_TTC_L	[7:0]	R/W	R	DMA total transfer count value (lower byte)	0x00
EPn_TTC_M	[7:0]	R/W	R	DMA total transfer count value (middle byte)	0x00
EPn_TTC_H	[7:0]	R/W	R	DMA total transfer count value (higher byte)	0x00

# 19

## MODEM INTERFACE

### OVERVIEW

This specification defines the interface between the Base-band Modem and the Application Processor for the data-exchange of these two devices (refer Figure 19-1). For the data-exchange, the AP (Application Processor, S3C24A0A) has a dual-ported SRAM buffer (on-chip) and the Modem chip can access that SRAM buffer using a typical asynchronous-SRAM interface.

Typically, the size of the SRAM buffer is 2KB. For the buffer status and Interrupt Requests, this specification also specifies a few of pre-defined special addresses.

The Modem chip can write data in the data buffer and write interrupt control-data to the interrupt-port address for the interrupt request to the AP. The AP reads that data when an interrupt request is accepted and the interrupt are cleared when the AP accesses the interrupt-port address. In the same manner, the AP can write data in the data buffer and write interrupt control-data to the interrupt-port address for the interrupt request to the Modem chip.

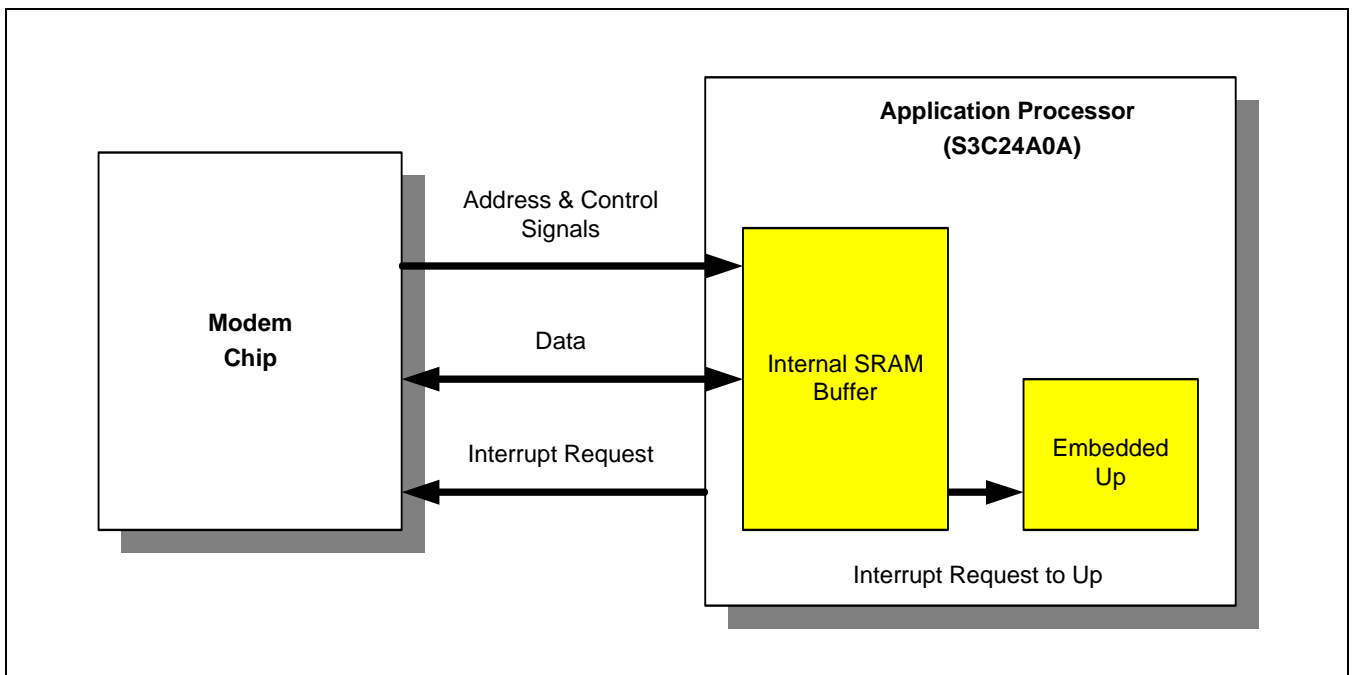

Figure 19-1. Modem Interface Overview

## FEATURES

- 8-bit parallel bus for data transfer
- 2K bytes internal SRAM buffer
- Interrupt request for data exchange
- Programmable interrupt port address

## HARDWARE INTERFACE

The Modem chip can access using an external memory interface (for example external SRAM). In this specification, the Modem chip can access the internal SRAM and special address ports of the AP using the 8-bit data-bus and the 2K-byte address-space (i.e. 8-bit data-bus and 11-bit address bus).

## SIGNAL DESCRIPTION

**Table 19-1. Modem Interface Signal Description**

Name	I/O (Note)	Active	Description
XmiIRQn	O	L	Interrupt request to the Modem chip
XmiDATA [7:0]	B	–	Data bus, driven by the Modem chip
XmiADR[10:0]	I	–	Address bus, driven by the Modem chip
XmiCSn	I	L	Chip select, driven by the Modem chip
XmiWEn	I	L	Write enable, driven by the Modem chip
XmiOEn	I	L	Read enable, driven by the Modem chip

**NOTE:** I/O direction is on the AP side. I: input O: output B: bi-direction

## INTERRUPT PORTS

Interrupts are requested or cleared if the Modem chip or the AP accesses the interrupt-port (predefined special addresses). Those special addresses can be configured by the AP and the default address-map is shown in the Table19-2.

**Table 19-2. Interrupt Ports and Interrupt-Request/Clear Conditions**

Address <sup>(1)</sup>	An Interrupt is Requested, When	The Interrupt is Cleared, When
0x7FE	The Modem chip writes	See note 2 <sup>(2)</sup>
0x7FF	The AP writes	The Modem chip reads

### NOTES:

1. This address is default value. It can be set to the other value by the SFR.
2. The interrupt is cleared by the interrupt controller of S3C24A0A

Modem chip or AP (S3C24A0A) can read the data that indicates what event happens – data transfer requested, data transfer done, special command issued, etc. - from interrupt port address. That data format should be defined for communication between the modem chip and AP.

ADDRESS MAPPING

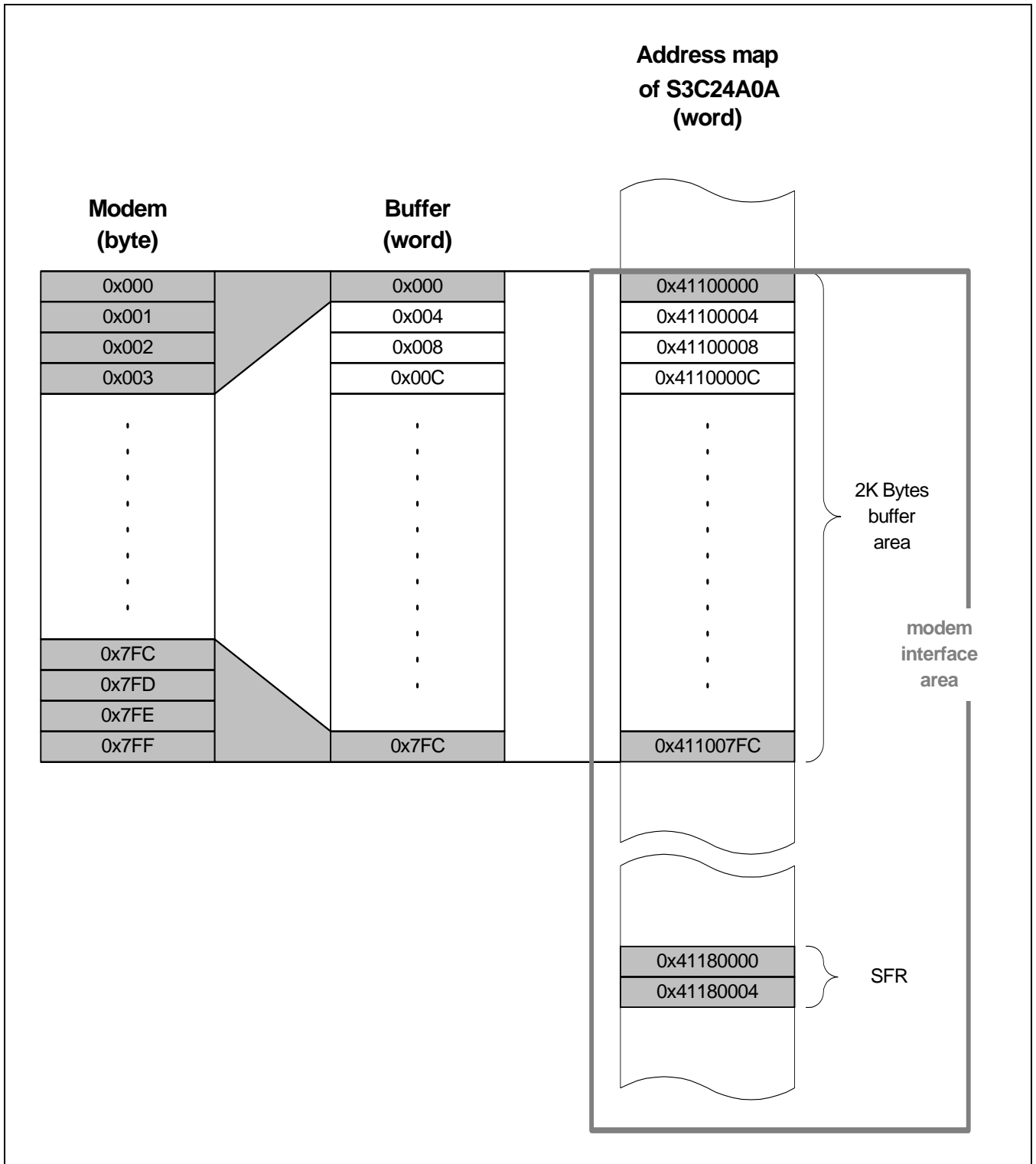

Figure 19-2. Modem Interface Address Mapping

TIMING DIAGRAM

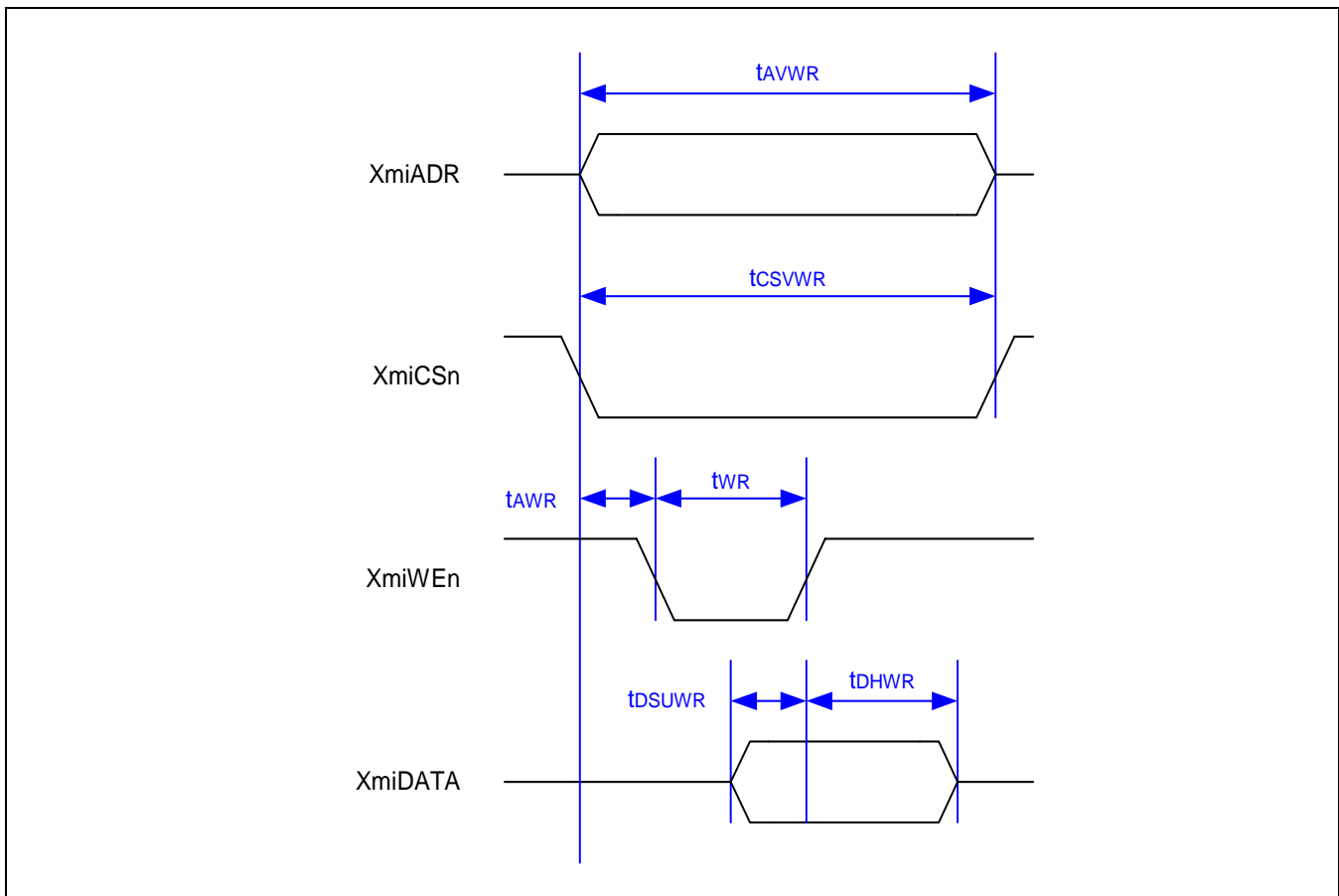

Figure 19-3. Modem Interface Write Timing Diagram

Table 19-3. Modem Interface Write Timing

Parameter	Description	Min (ns)	Max (ns)	Notes
$t_{AVWR}$	Address valid to address invalid	11 ns	–	
$t_{CSVWR}$	Chip select active	11 ns	–	
$t_{AWR}$	Address valid to write active	2 ns	–	
$T_{WR}$	Write active	5 ns	–	
$T_{DSUWR}$	Write data setup	3 ns	–	
$t_{DHWR}$	Write data hold	4 ns	–	

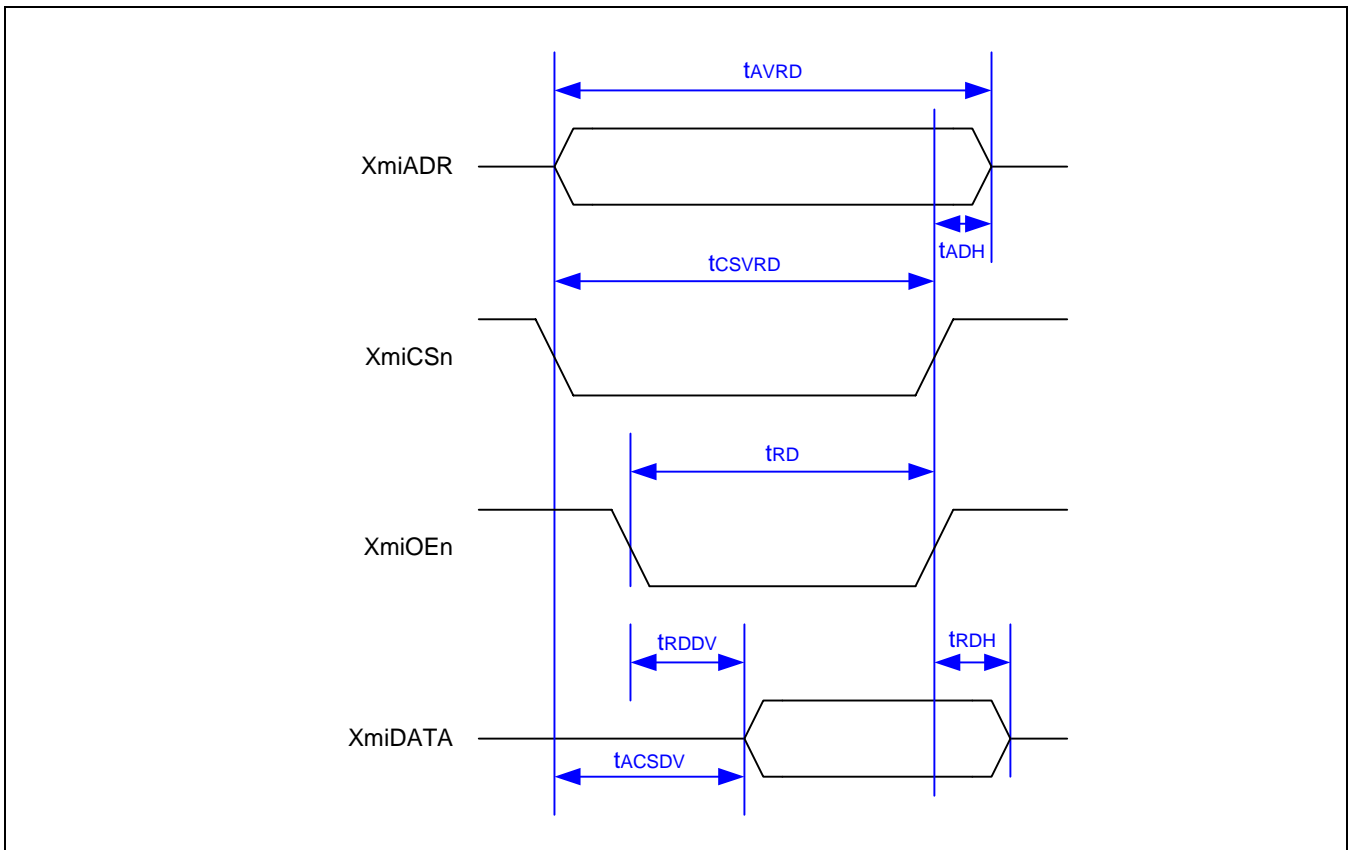

Figure 19-4. Modem Interface Read Timing Diagram

Table 19-4. Modem Interface Read Timing

Parameter	Description	Min	Max	Notes
tAVRD	Address valid to address invalid	20 ns	–	
tADH	Address hold	2.5 ns	–	
tCSV RD	Chip select active	17.5 ns	–	
tRD	Read active	17 ns	–	
tRDDV	Read active to data valid	–	11.5 ns	
tRDH	Read data hold	4 ns	–	
tACSDV	Address and chip select active to data valid	–	12 ns	

NOTE: Output load is 30pF at room temperature (25°C)

**SOFTWARE INTERFACE**

This modem interface provides a generic data-exchange method. This interface does not implement any other complex features except for the interrupt-request/clear such as automatic FIFO managements, etc. The software should be responsible for all other required functionalities for the data exchange between the modem chip and the AP such as the data exchange protocol, the data buffer managements, and etc.



**MODEM INTERFACE SPECIAL REGISTERS****INTERRUPT REQUEST TO AP REGISTER (INT2AP)**

Register	Address	R/W	Description	Reset Value
INT2AP	0x41180000	R/W	Interrupt request to AP register	0x000007FE

INT2AP	Bit	Description	Initial State
Reserved	[31:11]	Reserved	0
INT2AP_ADR	[10:0]	Modem interface requests the interrupt to AP when modem chip writes this address. This interrupt is cleared by the interrupt controller of AP.	7FE

**INTERRUPT REQUEST TO MODEM REGISTER (INT2MDM)**

Register	Address	R/W	Description	Reset Value
INT2MDM	0x41180004	R/W	Interrupt request to modem register	0x000007FF

INT2MDM	Bit	Description	Initial State
Reserved	[31:11]	Reserved	0
INT2MDM_ADR	[10:0]	Modem interface requests the interrupt to modem chip when AP writes this address and clears the interrupt when modem chip reads this address.	7FF

**NOTE:** It is recommended that AP writes data with byte access on the interrupt port because AP can overwrite the data in INT2AP if there are INT2AP and INT2MDM sharing the same word.

# 20

## GENERAL PURPOSE I/O PORTS

### OVERVIEW

The S3C24A0A has 32 multi-functional general-purpose input/output port pins (GPIO).

Each port can be easily configured by software to meet various system configuration and design requirements. You have to define which function of each pin is used before starting the main program. If the multiplexed functions on a pin are not used, the pin can be configured as I/O ports.

The GPIO module in the S3C24A0A has control-registers to configure the power-saving features for the whole chip interface. For example, it contains the control registers for the pin-status of the S3C24A0A that is in the SLEEP state (the SLEEP state is the state that the power source for the whole chip is off except for the power-management circuitry).

For the normal mode operation, the GPIO pins can be fully configured as an input port with or without pull-up register, an output port, a specific functional pin or an External Interrupt source.



Table 20-1. S3C24A0A Port Configuration Overview

Port	Selectable Pin Functions (Refers the GPIO port configuration registers – GPCON_U, GPCON_M & GPCON_L.)		
GP31	Input/output	XuRXD1	IrDA_RXD
GP30	Input/output	XuTXD1	IrDA_TXD
GP29	Input/output	XuRTSn1	IrDA_SDBW
GP28	Input/output	XuCTSn1	RTC_ALMINT
GP27	Input/output	EXTDMA_ACK1	XkpCOL4
GP26	Input/output	EXTDMA_ACK0	XkpCOL3
GP25	Input/output	EXTDMA_REQ1	XkpCOL2
GP24	Input/output	EXTDMA_REQ0	XkpCOL1
GP23	Input/output	PWM_TOUT3	XkpCOL0
GP22	Input/output	PWM_TOUT2	XkpROW4
GP21	Input/output	PWM_TOUT1	XkpROW3
GP20	Input/output	PWM_TOUT0	XkpROW2
GP19	Input/output	PWM_ECLK	XkpROW1
GP18	Input/output	EINT18	XkpROW0
GP17	Input/output	EINT17	XspiCLK
GP16	Input/output	EINT16	XspiMISO
GP15	Input/output	EINT15	XspiMOSI
GP14	Input/output	EINT14	RTC_ALMINT
GP13	Input/output	EINT13	Reserved
GP12	Input/output	EINT12	Reserved
GP11	Input/output	EINT11	Reserved
GP10	Input/output	Reserved	Reserved
GP9	Input/output	EINT9	Reserved
GP8	Input/output	EINT8	Reserved
GP7	Input/output	EINT7	Reserved
GP6	Input/output	EINT6	Reserved
GP5	Input/output	EINT5	PWM_TOUT3
GP4	Input/output	EINT4	PWM_TOUT2
GP3	Input/output	EINT3	PWM_TOUT1
GP2	Input/output	EINT2	PWM_TOUT0
GP1	Input/output	EINT1	PWM_ECLK
GP0	Input/output	EINT0	–

## PORT CONTROL DESCRIPTIONS

### GPIO PORT CONFIGURATION REGISTER FOR NORMAL MODE (GPCON\_U, GPCON\_M, GPCON\_L)

In the S3C24A0A, 32 pins are multiplexed pins. So, It is determined which function is selected for each pins. The PCON (port control register) determines which function is used for each pin.

If GP0 – GP9 are used for the wakeup signal in power down mode, these ports must be configured as an interrupt mode. The wake-up events are generated when the individual GPIO pin is configured as an external interrupt mode regardless of the interrupt mask bits.

### GPIO PORT DATA REGISTER FOR NORMAL MODE (GPDAT)

If Ports are configured as output ports, data can be written to the corresponding bit of GPDAT. If Ports are configured as input ports, the data can be read from the corresponding bit of GPDAT.

### GPIO PORT PULL-PU CONTROL REGISTER FOR NORMAL MODE (GPPU)

The port pull-up register controls the pull-up resistor enable/disable of each port group. When the corresponding bit is 0, the pull-up resistor of the pin is enabled. When 1, the pull-up resistor is disabled.

If the port pull-up register is enabled then the pull-up resistors work without pin's functional setting (input, output, EINTn and etc)

### EXTERNAL INTERRUPT CONTROL REGISTER (EXTINTCn/ EINTFLTn/ EINTMASK/ EINTPEND)

The 18 EINT ports are requested by various signaling methods. The EXTINTC register configures the signaling method among the low level trigger, high level trigger, falling edge trigger, rising edge trigger, and both edge trigger for the external interrupt request

All 18 EINT ports generate an interrupt when each port is configured as the interrupt mode and the corresponding interrupt is unmasked. However, even if the interrupt is masked to a corresponding interrupt port (EINTMASK), an interrupt pending bit (EINTPEND) is set when the port is configured as the interrupt mode.

The 8 EINT ports have a digital filter. (Refer to EINTFLTn register)

Only 10 EINT ports (EINT [9:0]) are used for wake-up sources. In the SLEEP mode, all wake-up sources are disabled when the nBATFLT signal is asserted to low (it will not generate a wake-up event nor a interrupt is pending).

Wake-up source is updated in EINTPEND including RTC alarm wake-up bit.

### PERIPHERAL PORT PULL-UP CONTROL REGISTER FOR NORMAL MODE (PERIPU)

The peripheral port pull-up control register controls internal pull-up resistor attached to the corresponding port pin. When the corresponding bit is 0, the pull-up resistor of the pin is enabled. When 1, the pull-up resistor is disabled.



**ALIVE CONTROL REGISTER (ALIVECON)**

These bits notify what kind of reset occurred and Battery fault has occurred or not. GPIO Output Data Register FOR Sleep Mode (GPDAT\_SLEEP)

GPIO port output data register in sleep mode. In sleep mode the value of GPDAT is meaningless.

**GPIO OUTPUT CONTROL REGISTER FOR SLEEP MODE (GPOEN\_SLEEP)**

GPIO port output control register for each port in sleep mode. In sleep mode the value of GPCON is meaningless.

**GPIO PULL-UP CONTROL REGISTER FOR SLEEP MODE (GPPU\_SLEEP)**

Control pull up resister attached to the corresponding GPIO port pin in sleep mode. In sleep mode the value of GPPU is meaningless.

**PERIPHERAL PORT OUTPUT DATA REGISTER FOR SLEEP MODE (PERIDAT\_SLEEPn)**

Peripheral port output data register in sleep mode.

**PERIPHERAL PORT OUTPUT CONTROL REGISTER FOR SLEEP MODE (PERIOEN\_SLEEPn)**

Peripheral port output control register for each port in sleep mode.

**PERIPHERAL PORT PULL-UP CONTROL REGISTER FOR SLEEP MODE (PERIPU\_SLEEP)**

Control pull up resister attached to the peripheral port in sleep mode. In sleep mode the value of PERIPU is meaningless.

**RESET COUNT COMPARE REGISTER (RSTCNT)**

These value control the duration of reset when wake-up from sleep mode.

**GENERAL PURPOSE RAM ARRAY (GPRAMn)**

General purpose RAM array, 16 x 32 bit.

**I/O PORT CONTROL REGISTER****GPIO UPPER PORT CONTROL REGISTER (GPCON\_U)**

Register	Address	R/W	Description	Reset Value
GPCON_U	0x44800000	R/W	Configures the pins of upper ports[31:19]	0x0

GPCON_U	Bit	Description	
GP31	[25:24]	00 = Input 10 = XuRXD1	01 = Output 11 = IrDA_RXD
GP30	[23:22]	00 = Input 10 = XuTXD1	01 = Output 11 = IrDA_TXD
GP29	[21:20]	00 = Input 10 = XuRTSn1	01 = Output 11 = IrDA_SDBW
GP28	[19:18]	00 = Input 10 = XuCTSn1	01 = Output 11 = RTC_ALMINT
GP27	[17:16]	00 = Input 10 = EXTDMA_ACK1	01 = Output 11 = XkpCOL4
GP26	[15:14]	00 = Input 10 = EXTDMA_ACK0	01 = Output 11 = XkpCOL3
GP25	[13:12]	00 = Input 10 = EXTDMA_REQ1	01 = Output 11 = XkpCOL2
GP24	[11:10]	00 = Input 10 = EXTDMA_REQ0	01 = Output 11 = XkpCOL1
GP23	[9:8]	00 = Input 10 = PWM_TOUT3	01 = Output 11 = XkpCOL0
GP22	[7:6]	00 = Input 10 = PWM_TOUT2	01 = Output 11 = XkpROW4
GP21	[5:4]	00 = Input 10 = PWM_TOUT1	01 = Output 11 = XkpROW3
GP20	[3:2]	00 = Input 10 = PWM_TOUT0	01 = Output 11 = XkpROW2
GP19	[1:0]	00 = Input 10 = PWM_ECLK	01 = Output 11 = XkpROW1

**GPIO MIDDLE PORT CONTROL REGISTER (GPCON\_M)**

If GP11 – GP18 is used for wakeup signals at power down mode, the ports will be set in Interrupt mode.

Register	Address	R/W	Description	Reset Value
GPCON_M	0x44800004	R/W	Configures the pins of middle ports[18:11]	0x0

GPCON_M	Bit	Description	
GP18	[15:14]	00 = Input 10 = EINT18	01 = Output 11 = XkpROW0
GP17	[13:12]	00 = Input 10 = EINT17	01 = Output 11 = XspiCLK
GP16	[11:10]	00 = Input 10 = EINT16	01 = Output 11 = XspiMISO
GP15	[9:8]	00 = Input 10 = EINT15	01 = Output 11 = XspiMOSI
GP14	[7:6]	00 = Input 10 = EINT14	01 = Output 11 = RTC_ALMINT
GP13	[5:4]	00 = Input 10 = EINT13	01 = Output 11 = Reserved
GP12	[3:2]	00 = Input 10 = EINT12	01 = Output 11 = Reserved
GP11	[1:0]	00 = Input 10 = EINT11	01 = Output 11 = Reserved

**GPIO LOWER PORT CONTROL REGISTER (GPCON\_L)**

If GP8 – GP10 is used for wakeup signals at power down mode, the ports will be set in Interrupt mode.

Register	Address	R/W	Description	Reset Value
GPCON_L	0x44800008	R/W	Configures the pins of lower ports[10:0]	0x0

GPCON_L	Bit	Description	
GP10	[21:20]	00 = Input 10 = Reserved	01 = Output 11 = Reserved
GP9	[19:18]	00 = Input 10 = EINT9	01 = Output 11 = Reserved
GP8	[17:16]	00 = Input 10 = EINT8	01 = Output 11 = Reserved
GP7	[15:14]	00 = Input 10 = EINT7	01 = Output 11 = Reserved
GP6	[13:12]	00 = Input 10 = EINT6	01 = Output 11 = Reserved
GP5	[11:10]	00 = Input 10 = EINT5	01 = Output 11 = PWM_TOUT3
GP4	[9:8]	00 = Input 10 = EINT4	01 = Output 11 = PWM_TOUT2
GP3	[7:6]	00 = Input 10 = EINT3	01 = Output 11 = PWM_TOUT1
GP2	[5:4]	00 = Input 10 = EINT2	01 = Output 11 = PWM_TOUT0
GP1	[3:2]	00 = Input 10 = EINT1	01 = Output 11 = PWM_ECLK
GP0	[1:0]	00 = Input 10 = EINT0	01 = Output 11 = Reserved

**GPIO PORT DATA REGISTER (GPDAT)**

Register	Address	R/W	Description	Reset Value
GPDAT	0x4480000C	R/W	The data register for all ports[31:0]	Undefined

GPDAT	Bit	Description
GP[31:0]	[31:0]	When the port is configured as input port, data from external sources can be read to the corresponding pin. When the port is configured as output port, data written in this register can be sent to the corresponding pin. When the port is configured as function pin, undefined value will be read.

**GPIO PORT PULL UP RESISTER CONTROL REGISTER (GPPU)**

Register	Address	R/W	Description	Reset Value
GPPU	0x44800010	R/W	Pull-up disable register for all ports[31:0]	0x0
Reserved	0x44800014	–	Reserved	Undefined

GPPU	Bit	Description
GP[31:0]	[31:0]	0 = The pull up function attached to to the corresponding port pin is enabled. 1 = The pull up function is disabled.

**EXTERNAL INTERRUPT CONTROL REGISTER (EXTINTC0)**

The 18 external interrupts can be requested by various signaling methods. The EXTINTC register configures the signaling method between the level trigger and edge trigger for the external interrupt request, and also configures the signal polarity.

To recognize the level interrupt, the valid logic level on EXTINTCn pin must be retained for 40ns at least because of the noise filter. (EINT[9:0])

Register	Address	R/W	Description	Reset Value
EXTINTC0	0x44800018	R/W	External Interrupt control Register 0	0x0

EXTINTC0	Bit	Description
Reserved	[11]	This bit is reserved and the value should be '0'
EXTINT2	[10:8]	Setting the signaling method of the EINT2. 000 = Low level                      001 = High level 01x = Falling edge triggered      10x = Rising edge triggered 11x = Both edge triggered
Reserved	[7]	This bit is reserved and the value should be '0'
EXTINT1	[6:4]	Setting the signaling method of the EINT1. 000 = Low level                      001 = High level 01x = Falling edge triggered      10x = Rising edge triggered 11x = Both edge triggered
Reserved	[3]	This bit is reserved and the value should be '0'
EXTINT0	[2:0]	Setting the signaling method of the EINT0. 000 = Low level                      001 = High level 01x = Falling edge triggered      10x = Rising edge triggered 11x = Both edge triggered



**EXTERNAL INTERRUPT CONTROL REGISTER (EXTINTC1)**

Register	Address	R/W	Description	Reset Value
EXTINTC1	0x448001C	R/W	External interrupt control register 1	0x0

EXTINTC1	Bit	Description
Reserved	[31:27]	This bit is reserved and the value should be '0'
EXTINT9	[26:24]	Setting the signaling method of the EINT9. 000 = Low level                      001 = High level 01x = Falling edge triggered      10x = Rising edge triggered 11x = Both edge triggered
Reserved	[23]	This bit is reserved and the value should be '0'
EXTINT8	[22:20]	Setting the signaling method of the EINT8. 000 = Low level                      001 = High level 01x = Falling edge triggered      10x = Rising edge triggered 11x = Both edge triggered
Reserved	[19]	This bit is reserved and the value should be '0'
EXTINT7	[18:16]	Setting the signaling method of the EINT7. 000 = Low level                      001 = High level 01x = Falling edge triggered      10x = Rising edge triggered 11x = Both edge triggered
Reserved	[15]	This bit is reserved and the value should be '0'
EXTINT6	[14:12]	Setting the signaling method of the EINT6. 000 = Low level                      001 = High level 01x = Falling edge triggered      10x = Rising edge triggered 11x = Both edge triggered
Reserved	[11]	This bit is reserved and the value should be '0'
EXTINT5	[10:8]	Setting the signaling method of the EINT5. 000 = Low level                      001 = High level 01x = Falling edge triggered      10x = Rising edge triggered 11x = Both edge triggered
Reserved	[7]	This bit is reserved and the value should be '0'
EXTINT4	[6:4]	Setting the signaling method of the EINT4. 000 = Low level                      001 = High level 01x = Falling edge triggered      10x = Rising edge triggered 11x = Both edge triggered
Reserved	[3]	This bit is reserved and the value should be '0'
EXTINT3	[2:0]	Setting the signaling method of the EINT3. 000 = Low level                      001 = High level 01x = Falling edge triggered      10x = Rising edge triggered 11x = Both edge triggered

**EXTERNAL INTERRUPT CONTROL REGISTER (EXTINTC2)**

Register	Address	R/W	Description	Reset Value
EXTINTC2	0x44800020	R/W	External interrupt control register 2	0x0

EXTINTC2	Bit	Description
FLTEN18	[31]	Filter Enable for EINT18    0 = Disable                      1= Enable
EXTINT18	[30:28]	Setting the signaling method of the EINT18. 000 = Low level                      001 = High level 01x = Falling edge triggered      10x = Rising edge triggered 11x = Both edge triggered
FLTEN17	[27]	Filter Enable for EINT17    0 = Disable                      1= Enable
EXTINT17	[26:24]	Setting the signaling method of the EINT17. 000 = Low level                      001 = High level 01x = Falling edge triggered      10x = Rising edge triggered 11x = Both edge triggered
FLTEN16	[23]	Filter Enable for EINT16    0 = Disable                      1= Enable
EXTINT16	[22:20]	Setting the signaling method of the EINT16. 000 = Low level                      001 = High level 01x = Falling edge triggered      10x = Rising edge triggered 11x = Both edge triggered
FLTEN15	[19]	Filter Enable for EINT15    0 = Disable                      1= Enable
EXTINT15	[18:16]	Setting the signaling method of the EINT15. 000 = Low level                      001 = High level 01x = Falling edge triggered      10x = Rising edge triggered 11x = Both edge triggered
FLTEN14	[15]	Filter Enable for EINT14    0 = Disable                      1= Enable
EXTINT14	[14:12]	Setting the signaling method of the EINT14. 000 = Low level                      001 = High level 01x = Falling edge triggered      10x = Rising edge triggered 11x = Both edge triggered
FLTEN13	[11]	Filter Enable for EINT13    0 = Disable                      1= Enable
EXTINT13	[10:8]	Setting the signaling method of the EINT13. 000 = Low level                      001 = High level 01x = Falling edge triggered      10x = Rising edge triggered 11x = Both edge triggered
FLTEN12	[7]	Filter Enable for EINT12    0 = Disable                      1= Enable
EXTINT12	[6:4]	Setting the signaling method of the EXTINT12. 000 = Low level                      001 = High level 01x = Falling edge triggered      10x = Rising edge triggered 11x = Both edge triggered
FLTEN11	[3]	Filter Enable for EINT11    0 = Disable                      1= Enable
EXTINT11	[2:0]	Setting the signaling method of the EINT11. 000 = Low level                      001 = High level 01x = Falling edge triggered      10x = Rising edge triggered 11x = Both edge triggered



**EXTERNAL INTERRUPT FILTER CONTROL REGISTER (EINTFLTn)**

EINTFLTn control the length of filter for 8 external interrupts (EINT[18:11]).

Register	Address	R/W	Description	Reset Value
EINTFLT0	0x44800024	R/W	External interrupt control register	0x0
EINTFLT1	0x44800028	R/W	External interrupt control register	0x0

EINTFLT0	Bit	Description
FLTCLK14	[31]	Filter clock of EINT14 0 = PCLK                      1= XsEXTCLK/XsXTIN/RTC_CLK (NOTE)
EINTFLT14	[30:24]	Filtering width of EINT14
FLTCLK13	[23]	Filter clock of EINT13 0 = PCLK                      1= XsEXTCLK/XsXTIN/RTC_CLK (NOTE)
EINTFLT13	[22:16]	Filtering width of EINT13
FLTCLK12	[15]	Filter clock of EINT12 0 = PCLK                      1= XsEXTCLK/XsXTIN/RTC_CLK (NOTE)
EINTFLT12	[14:8]	Filtering width of EINT12
FLTCLK11	[7]	Filter clock of EINT11 0 = PCLK                      1= XsEXTCLK/XsXTIN/RTC_CLK (NOTE)
EINTFLT11	[6:0]	Filtering width of EINT11

EINTFLT1	Bit	Description
FLTCLK18	[31]	Filter clock of EINT18 0 = PCLK                      1= XsEXTCLK/XsXTIN/RTC_CLK (NOTE)
EINTFLT18	[30:24]	Filtering width of EINT18
FLTCLK17	[23]	Filter clock of EINT17 0 = PCLK                      1= XsEXTCLK/XsXTIN/RTC_CLK (NOTE)
EINTFLT17	[22:16]	Filtering width of EINT17
FLTCLK16	[15]	Filter clock of EINT16 0 = PCLK                      1= XsEXTCLK/XsXTIN/RTC_CLK (NOTE)
EINTFLT16	[14:8]	Filtering width of EINT16
FLTCLK15	[7]	Filter clock of EINT15 0 = PCLK                      1= XsEXTCLK/XsXTIN/RTC_CLK (NOTE)
EINTFLT15	[6:0]	Filtering width of EINT15

**NOTE:** When the filter clock bit is '1', the source clock for filter is determined by the value of XgREFCLKSEL[0] pin and the value of ALIVECON[0].

**EXTERNAL INTERRUPT MASK REGISTER (EINTMASK))**

Interrupt mask register for 18 external interrupts (EINT[18:11, 9:0]).

Register	Address	R/W	Description	Reset Value
EINTMASK	0x44800034	R/W	External interrupt mask register	0x0007FFFF

EINTMASK	Bit	Description
EINT18	[18]	0 = Enable Interrupt 1= Masked
EINT17	[17]	0 = Enable Interrupt 1= Masked
EINT16	[16]	0 = Enable Interrupt 1= Masked
EINT15	[15]	0 = Enable Interrupt 1= Masked
EINT14	[14]	0 = Enable Interrupt 1= Masked
EINT13	[13]	0 = Enable Interrupt 1= Masked
EINT12	[12]	0 = Enable Interrupt 1= Masked
EINT11	[11]	0 = Enable Interrupt 1= Masked
Reserved	[10]	Reserved
EINT9	[9]	0 = Enable Interrupt 1= Masked
EINT8	[8]	0 = Enable Interrupt 1= Masked
EINT7	[7]	0 = Enable Interrupt 1= Masked
EINT6	[6]	0 = Enable Interrupt 1= Masked
EINT5	[5]	0 = Enable Interrupt 1= Masked
EINT4	[4]	0 = Enable Interrupt 1= Masked
EINT3	[3]	0 = Enable Interrupt 1= Masked
EINT2	[2]	0 = Enable Interrupt 1= Masked
EINT1	[1]	0 = Enable Interrupt 1= Masked
EINT0	[0]	0 = Enable Interrupt 1= Masked

**EXTERNAL INTERRUPT PENDING REGISTER (EINTPEND)**

Interrupt pending register for 18 external interrupts (EINT[18:11, 9:0]). If the S3C24A0A wake-up from sleep mode by RTC alarm, the PMWKUP bit is set instead of INT\_RTC bit in INTPND and INTSRCPND register. You can clear a specific bit of EINTPEND register by writing a data ('1') to this register. It clears only the bit positions of EINTPEND corresponding to those set to one in the data. The bit positions corresponding to those that are set to 0 in the data remains as they are with no change.

Register	Address	R/W	Description	Reset Value
EINTPEND	0x44800038	R/W	External interrupt pending register	0x0

EINTPEND	Bit	Description
PMWKUP	[19]	RTC Alarm Interrupt. 0 = Not occur      1= Occur interrupt
EINT18	[18]	0 = Not occur      1= Occur interrupt
EINT17	[17]	0 = Not occur      1= Occur interrupt
EINT16	[16]	0 = Not occur      1= Occur interrupt
EINT15	[15]	0 = Not occur      1= Occur interrupt
EINT14	[14]	0 = Not occur      1= Occur interrupt
EINT13	[13]	0 = Not occur      1= Occur interrupt
EINT12	[12]	0 = Not occur      1= Occur interrupt
EINT11	[11]	0 = Not occur      1= Occur interrupt
Reserved	[10]	Reserved
EINT9	[9]	0 = Not occur      1= Occur interrupt
EINT8	[8]	0 = Not occur      1= Occur interrupt
EINT7	[7]	0 = Not occur      1= Occur interrupt
EINT6	[6]	0 = Not occur      1= Occur interrupt
EINT5	[5]	0 = Not occur      1= Occur interrupt
EINT4	[4]	0 = Not occur      1= Occur interrupt
EINT3	[3]	0 = Not occur      1= Occur interrupt
EINT2	[2]	0 = Not occur      1= Occur interrupt
EINT1	[1]	0 = Not occur      1= Occur interrupt
EINT0	[0]	0 = Not occur      1= Occur interrupt

**PERIPHERAL PORT PULL UP CONTROL REGISTER (PERIPU)**

Pull up control register for peripheral port in normal mode.

Register	Address	R/W	Description	Reset Value
PERIPU	0x44800040	R/W	Controlled pull-up register	0x00004000

PERIPU	Bit	Description
Reserved	[31:27]	Reserved
PERIPU26	[26]	Pull-up for XmsSDIO port 0 = Enabled                      1 = Disabled
Reserved	[25]	Reserved
PERIPU24	[24]	Pull-up for XsdDAT[3:0] ports 0 = Enabled                      1 = Disabled
Reserved	[23:15]	Reserved
PERIPU14	[14]	Pull-up for XrADDR[25:18] ports 0 = Enabled                      1 = Disabled
PERIPU13	[13]	Pull-up for XciCDATA[7:0] ports 0 = Enabled                      1 = Disabled
PERIPU12	[12]	Pull-up for XmiADR[10:0] ports 0 = Enabled                      1 = Disabled
PERIPU11	[11]	Pull-up for XmiDATA[7:0] ports 0 = Enabled                      1 = Disabled
PERIPU10	[10]	Pull-up for XspiCLK and XspiMOSI ports 0 = Enabled                      1 = Disabled
PERIPU9	[9]	Pull-up for X2sLRCK and X2sCLK ports 0 = Enabled                      1 = Disabled
PERIPU8	[8]	Pull-up for XspiMISO port 0 = Enabled                      1 = Disabled
Reserved	[7:5]	Reserved
PERIPU4	[4]	Pull-up for XrDATA[15:0] ports 0 = Enabled                      1 = Disabled
PERIPU3	[3]	Reserved
PERIPU2	[2]	Pull-up for XpDATA[31:0] ports 0 = Enabled                      1 = Disabled
Reserved	[1:0]	Reserved

**ALIVE CONTROL REGISTER (ALIVECON)**

ALIVECON register reports reset status and battery fault status. The clock for alive-block in sleep mode can be selected.

Register	Address	R/W	Description	Reset Value
ALIVECON	0x44800044	R/W	Alive control register	0x0

ALIVECON	Bit	Description
BATFLT	[7]	0 = Battery fault has not been asserted 1 = Battery fault has been asserted
SOFTRST	[6]	0 = SW reset has not been asserted 1 = SW reset has been asserted
WDTRST	[5]	0 = Watch-Dog-Timer reset has not been asserted 1 = Watch-Dog-Timer reset has been asserted
WARMRST	[4]	0 = Warm reset has not been asserted 1 = Warm reset has been asserted
Reserved	[3:2]	Reserved
SLEEPRST	[1]	This bit does not set automatically. Users must set this bit before enter sleep mode. 0 = Sleep mode wake-up operation has not been asserted 1 = Sleep mode wake-up operation has been asserted
AliveCLKsel	[0]	XsXTIN and XsEXTCLK is selected by XgREFCLKSEL[0] pin when the XgREFCLKSEL[0] is high, the EXT_CLK is selected. 0 = XsXTIN / XsEXTCLK 1 = RTC_CLK

**NOTE:** The asserted value, which is set automatically by hardware, should be cleared by software after checking the status.

**GPIO OUTPUT DATA REGISTER (GPDAT\_SLEEP)**

GPIO port output data register in sleep mode. In sleep mode the value of GPDAT is meaningless.

Register	Address	R/W	Description	Reset Value
GPDAT_SLEEP	0x44800048	R/W	Output data for sleep mode	0x0

GPDAT_SLEEP	Bit	Description
GPDAT_SLEEP[31:0]	[31:0]	these value are propagated to corresponding ports/pins, if GPOEN_SLEEP is activated at sleep mode.

**GPIO OUTPUT CONTROL REGISTER FOR SLEEP MODE (GPOEN\_SLEEP)**

GPOEN\_SLEEP register controls GPIO port with output or Hi-z state.

Register	Address	R/W	Description	Reset Value
GPOEN_SLEEP	0x4480004C	R/W	GPIO output enable control for sleep mode	0xFFFF_FFFF

GPOEN_SLEEP	Bit	Description
GPOEN_SLEEP[31:0]	[31:0]	0 = Make GPIO output port in sleep mode. 1 = Make GPIO Hi-z state in sleep mode.

**GPIO PULL UP CONTROL REGISTER FOR SLEEP MODE (GPPU\_SLEEP)**

Pull up control register for GPIO port in sleep mode.

Register	Address	R/W	Description	Reset Value
GPPU_SLEEP	0x44800050	R/W	GPIO pull-up control register for sleep mode	0xFFFF_FFFF

GPPU_SLEEP	Bit	Description
GPPU_SLEEP[31:0]	[31:0]	0 = The pull up function attached to to the corresponding port pin is enabled in sleep mode. 1 = The pull up function is disabled in sleep mode.



**PERIPHERAL PORT OUTPUT DATA REGISTER FOR SLEEP MODE (PERIDAT\_SLEEP0)**

Peripheral port output data register in sleep mode. These data is meaningful only when the PERIOEN\_SLEEP is enabled.

Register	Address	R/W	Description	Reset Value
PERIDAT_SLEEP0	0x44800054	R/W	Output data register for sleep mode	0x8095_A220

PERIDAT_SLEEP0	Bit	Description	Reset Value
PERIDAT031	[31]	XsRSTOUTn port output data	1
PERIDAT030	[30]	XmsSDIO and XsdDAT[3:0] ports output data	0
PERIDAT029	[29]	XmsSCLKO and XmsBS ports output data	0
Reserved	[28]	Reserved	0
PERIDAT027	[27]	XvVD[17:0] ports output data	0
PERIDAT026	[26]	XvVSYNC, XvHSYNC and XvVCLK ports output data	0
PERIDAT025	[25]	XciRSTn port output data	0
PERIDAT024	[24]	XciCLK port output data	0
PERIDAT023	[23]	XmiLRQn port output data	1
PERIDAT022	[22]	XmiDATA[7:0] and XgMONHCLK ports output data	0
PERIDAT021	[21]	XudDN port output data	0
PERIDAT020	[20]	XudDP port output data	1
PERIDAT019	[19]	XusDN[1:0] ports output data	0
PERIDAT018	[18]	XusDP[1:0] ports output data	1
PERIDAT017	[17]	X97SYNC and X97SDO ports output data	0
PERIDAT016	[16]	X97RESETh port output data	1
PERIDAT015	[15]	XspiCLK and XspiMOSI ports output data	1
PERIDAT014	[14]	X2sCDCLK and X2sDO ports output data	0
PERIDAT013	[13]	X2sLRCK and X2sCLK ports output data	1
PERIDAT012	[12]	XuTXD0 and XuRTS0 ports output data	0
Reserved	[11:8]	Reserved	2
PERIDAT07	[7]	XpDATA[31:0] ports output data	0
PERIDAT06	[6]	XpDQM[3:0] and XpADDR[14:0] ports output data	0
PERIDAT05	[5]	XpCSn[1:0], XpCASn and XpRASn ports output data	1
PERIDAT04	[4]	XpCKE and XpSCLK ports output data	0
PERIDAT03	[3]	XrDATA[15:0] ports output data	0
PERIDAT02	[2]	XrADDR[25:18] ports output data	0
PERIDAT01	[1]	XrCSn[2:0], XrWEn, XrOEn and XrnWBE[1:0] ports output data	0
PERIDAT00	[0]	XfCLE and XfALE ports output data	0

**PERIPHERAL PORT OUTPUT DATA REGISTER FOR SLEEP MODE (PERIDAT\_SLEEP1)**

Peripheral port output data register in sleep mode. These data is meaningful only when the PERIOEN\_SLEEP is enabled.

Register	Address	R/W	Description	Reset Value
PERIDAT_SLEEP1	0x44800058	R/W	Output data register for sleep mode	0x8095_A220

PERIDAT_SLEEP1	Bit	Description	Reset Value
Reserved	[31:7]	Reserved	0
PERIDAT16	[6]	XpWEn port output data	1
PERIDAT15	[5]	XjRTCK port output data	1
PERIDAT14	[4]	X2cSCL, X2cSDA ports output data	1
Reserved	[3]	Reserved	1
PERIDAT12	[2]	XrADDR[17:0] ports output data	0
PERIDAT11	[1]	XspiMISO port output data	1
PERIDAT10	[0]	XjTDO port output data	0

**PERIPHERAL PORT OUTPUT CONTROL REGISTER FOR SLEEP MODE (PERIOEN\_SLEEP0)**

Peripheral port output control register for each port in sleep mode. PERIOEN\_SLEEP[8, 6] bits are used for suspend enabler also in stop mode.

Register	Address	R/W	Description	Reset Value
PERIOEN_SLEEP0	0x4480005C	R/W	Output control register0 for sleep mode	0x003F_03E3

PERIOEN_SLEEP0	Bit	Description	Reset Value
Reserved	[31:22]	Reserved	0
PERIOEN021	[21]	Select XmiDATA[7:0] pins output or Hi-z 0 = Enable(Output)                      1 = Disable(Hi-z)	1
Reserved	[20:16]	Reserved	0x1f
PERIOEN015	[15]	Select XjTDO pin output or Hi-z 0 = Enable(Output)                      1 = Disable(Hi-z)	0
PERIOEN014	[14]	Select XsXTOUT pin output or Hi-z 0 = Enable(Output)                      1 = Disable(Hi-z)	0
PERIOEN013	[13]	Select XsdDAT[3:0] pins output or Hi-z 0 = Enable(Output)                      1 = Disable(Hi-z)	0
PERIOEN012	[12]	Select XmsSDIO pin output or Hi-z 0 = Enable(Output)                      1 = Disable(Hi-z)	0
Reserved	[11]	Reserved	0
PERIOEN010	[10]	Select XvVD[17:0] pins output or Hi-z 0 = Enable(Output)                      1 = Disable(Hi-z)	0
Reserved	[9]	Reserved	1
PERIOEN08	[8]	Select XudDP and XudDN pins output or Hi-z 0 = Enable(Output)                      1 = Disable(Hi-z)	1
Reserved	[7]	Reserved	1
PERIOEN06	[6]	Select XusDP[1:0] and XusDN[1:0] pins output or Hi-z 0 = Enable(Output)                      1 = Disable(Hi-z)	1
PERIOEN05	[5]	Select XspiCLK and XspiMOSI pins output or Hi-z 0 = Enable(Output)                      1 = Disable(Hi-z)	1
PERIOEN04	[4]	Select X2sLRCK and X2sCLK pins output or Hi-z 0 = Enable(Output)                      1 = Disable(Hi-z)	0
PERIOEN03	[3]	Select XspiMISO pin output or Hi-z 0 = Enable(Output)                      1 = Disable(Hi-z)	0
Reserved	[2]	Reserved	0
PERIOEN01	[1]	Select XpDATA[31:0] pins output or Hi-z 0 = Enable(Output)                      1 = Disable(Hi-z)	1
PERIOEN00	[0]	Select XrDATA[15:0] pins output or Hi-z 0 = Enable(Output)                      1 = Disable(Hi-z)	1

**PERIPHERAL PORT OUTPUT CONTROL REGISTER FOR SLEEP MODE (PERIOEN\_SLEEP1)**

Register	Address	R/W	Description	Reset Value
PERIOEN_SLEEP1	0x44800060	R/W	Output control register1 for sleep mode	0x0037_D802

PERIOEN_SLEEP1	Bit	Description	Reset Value
Reserved	[31:20]	Reserved	0x3
PERIOEN119	[19]	Select XsRSTOUTn pin output or Hi-z 0 = Enable(Output)                      1 = Disable(Hi-z)	0
PERIOEN118	[18]	Select XmsBS and XmsSCLKO pins output or Hi-z 0 = Enable(Output)                      1 = Disable(Hi-z)	1
PERIOEN117	[17]	Select XvDEN pin output or Hi-z 0 = Enable(Output)                      1 = Disable(Hi-z)	1
PERIOEN116	[16]	Select XvVSYNC, XvHSYNC and XvVCLK pins output or Hi-z 0 = Enable(Output)                      1 = Disable(Hi-z)	1
PERIOEN115	[15]	Select XciRSTn pin output or Hi-z 0 = Enable(Output)                      1 = Disable(Hi-z)	1
PERIOEN114	[14]	Select XciCLK pin output or Hi-z 0 = Enable(Output)                      1 = Disable(Hi-z)	1
PERIOEN113	[13]	Select XmilRQn and XgMONHCLK pins output or Hi-z 0 = Enable(Output)                      1 = Disable(Hi-z)	0
PERIOEN112	[12]	Select X97SYNC and X97SDO pins output or Hi-z 0 = Enable(Output)                      1 = Disable(Hi-z)	1
PERIOEN111	[11]	Select X97RESETn pin output or Hi-z 0 = Enable(Output)                      1 = Disable(Hi-z)	1
PERIOEN110	[10]	Select X2sCDCLK and X2sDO pins output or Hi-z 0 = Enable(Output)                      1 = Disable(Hi-z)	0
PERIOEN19	[9]	Select XuTXD0 and XuRTSn0 pins output or Hi-z 0 = Enable(Output)                      1 = Disable(Hi-z)	0
Reserved	[8:6]	Reserved	0
PERIOEN15	[5]	Select XpDQM[3:0] and XpADDR[14:0] pins output or Hi-z 0 = Enable(Output)                      1 = Disable(Hi-z)	0
PERIOEN14	[4]	Select XpWEn, XpCSn[1:0], XpCASn and XpRASn pins output or Hi-z 0 v Enable(Output)                      1 = Disable(Hi-z)	0
PERIOEN13	[3]	Select XpCKE and XpSCLK pins output or Hi-z 0 = Enable(Output)                      1 = Disable(Hi-z)	0
PERIOEN12	[2]	Select XrADDR[17:0] pins output or Hi-z 0 = Enable(Output)                      1 v Disable(Hi-z)	0
PERIOEN11	[1]	Select XrCSn[2:0], XrWEn, XrOEn and XrnWBE[1:0] pins output or Hi-z 0 = Enable(Output)                      1 = Disable(Hi-z)	1
PERIOEN10	[0]	Select XfCLE and XfALE pins output or Hi-z 0 = Enable(Output)                      1 = Disable(Hi-z)	0



**PERIPHERAL PORT PULL UP CONTROL REGISTER FOR SLEEP MODE (PERIPU\_SLEEP)**

Control pull up resistor attached to the corresponding peripheral port pin in sleep mode.

Register	Address	R/W	Description	Reset Value
PERIPU_SLEEP	0x44800064	R/W	Controlled pull-up register for sleep mode	0x0

PERIPU_SLEEP	Bit	Description
Reserved	[32:27]	Reserved
PERIPU26	[26]	Control internal pull-up resistor for XmsSDIO in sleep mode 0 = Enabled 1 = Disabled
Reserved	[25]	Reserved
PERIPU24	[24]	Control internal pull-up resistor for XsdDAT[3:0] in sleep mode 0 = Enabled 1 = Disabled
Reserved	[23:12]	Reserved
PERIPU11	[11]	Control internal pull-up resistor for XmiDATA[7:0] in sleep mode 0 = Enabled 1 = Disabled
PERIPU10	[10]	Control internal pull-up resistor for XspiCLK and XspiMOSI in sleep mode 0 = Enabled 1 = Disabled
PERIPU9	[9]	Control internal pull-up resistor for X2sLRCK and X2sCLK in sleep mode 0 = Enabled 1 = Disabled
PERIPU8	[8]	Control internal pull-up resistor for XspiMISO in sleep mode 0 = Enabled 1 = Disabled
Reserved	[7:5]	Reserved in sleep mode
PERIPU4	[4]	Control internal pull-up resistor for XrDATA[15:0] in sleep mode 0 = Enabled 1 = Disabled
Reserved	[3]	Reserved
PERIPU2	[2]	Control internal pull-up resistor for XpDATA[31:0] in sleep mode 0 = Enabled 1 = Disabled
Reserved	[1:0]	Reserved

**RESET COUNT COMPARE REGISTER (RstCnt)**

Compared counter value for the Power Settle-down-time wait.

Register	Address	R/W	Description	Reset Value
RstCnt	0x44800068	R/W	Reset count compare register	0x0

RSTCNT	Bit	Description
RstCnt[7:0]	[7:0]	<p>After wake-up from the SLEEP mode, the S3C24A0A power-management logic adds an external power-source settle-down-wait time by holding the internal reset signal to low (forces the internal reset is active).</p> <p>The AliveCLK is the reference clock source for the power-management circuitry. It can be selected from the external clock sources or the RTC clock.</p> <p>Reset duration = (RstCnt[7] x 16384  RstCnt[6] X 3 X 2048  RstCnt[5] X 7 X 256  RstCnt[4] X 7 X 32  RstCnt[3] X 3 X 8  RstCnt[2:0]  ) x 32 x 1/AliveCLK</p>

**GENERAL PURPOSE RAM ARRAY (GPRAMn)**

General purpose RAM array, 16x32-bit. These memory array connected alive-block, so their contents be maintained in sleep mode.

Register	Address	R/W	Description	Reset Value
GPRAM0	0x44800080	R/W	General purpose RAM word 0	Undefined
GPRAM1	0x44800084	R/W	General purpose RAM word 1	Undefined
GPRAM2	0x44800088	R/W	General purpose RAM word 2	Undefined
GPRAM3	0x4480008C	R/W	General purpose RAM word 3	Undefined
GPRAM4	0x44800090	R/W	General purpose RAM word 4	Undefined
GPRAM5	0x44800094	R/W	General purpose RAM word 5	Undefined
GPRAM6	0x44800098	R/W	General purpose RAM word 6	Undefined
GPRAM7	0x4480009C	R/W	General purpose RAM word 7	Undefined
GPRAM8	0x448000A0	R/W	General purpose RAM word 8	Undefined
GPRAM9	0x448000A4	R/W	General purpose RAM word 9	Undefined
GPRAM10	0x448000A8	R/W	General purpose RAM word 10	Undefined
GPRAM11	0x448000AC	R/W	General purpose RAM word 11	Undefined
GPRAM12	0x448000B0	R/W	General purpose RAM word 12	Undefined
GPRAM13	0x448000B4	R/W	General purpose RAM word 13	Undefined
GPRAM14	0x448000B8	R/W	General purpose RAM word 14	Undefined
GPRAM15	0x448000BC	R/W	General purpose RAM word 15	Undefined



# 21

## CAMERA INTERFACE

### OVERVIEW

This specification defines the interface for camera. The camera interface of S3C24A0A consists of seven parts. They are the pattern mux, capturing unit, preview scaler, codec scaler, preview DMA, codec DMA, and SFR. The camera interface supports ITU R BT-601/656 YCbCr 8/16-bit standard. Maximum input size is 4096x4096 pixels (2048x2048 pixels for scaling). There are two scalers. The one is the preview scaler, which is dedicated to generate small size image as PIP(Picture In Picture). The other one is the codec scaler, which is dedicated to generate codec useful image like plane type YCbCr 4:2:0 or 4:2:2. Two master DMAs can do mirroring and rotating the captured image for mobile environments. These features are very useful at folder type cellular phone. And test pattern generation can be used to calibration of input sync signals as HREF, VSYNC. Also, video sync signals and pixel clock polarity can be inverted in the camera interface side with using register setting.

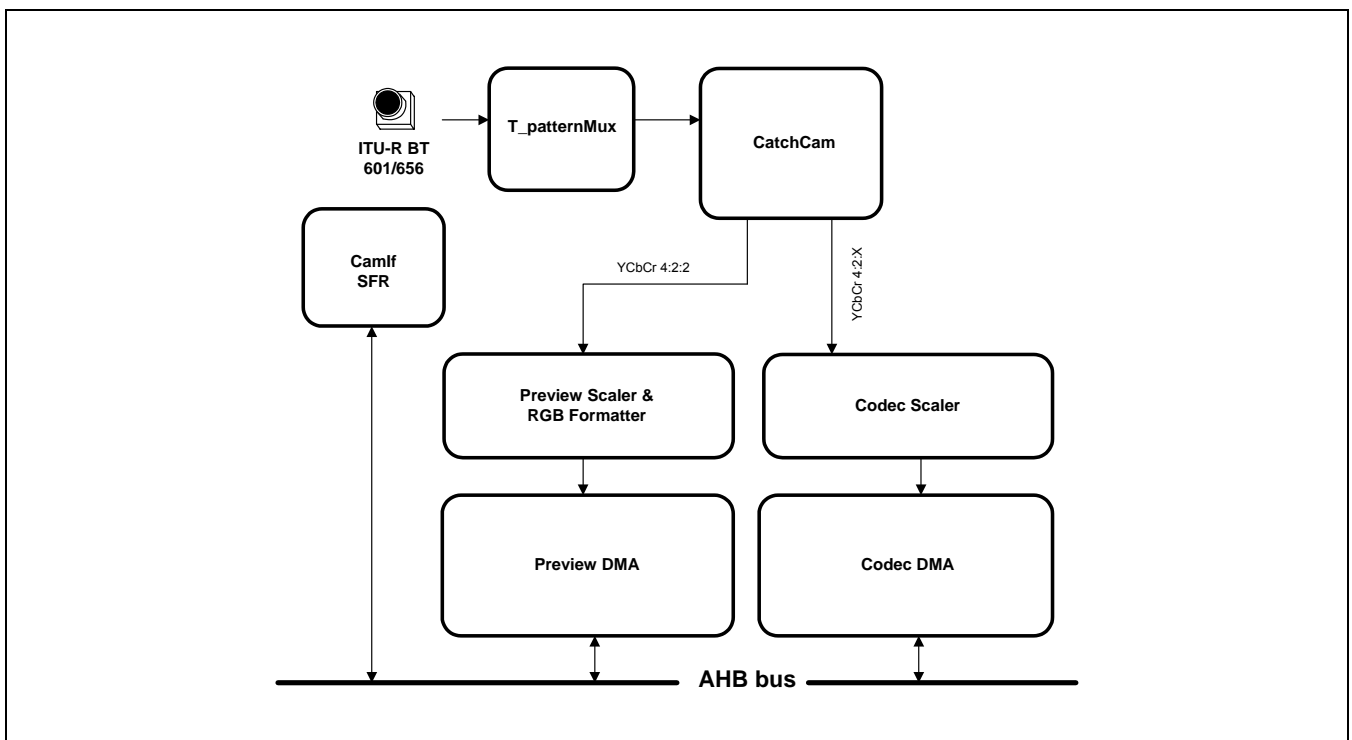

Figure 21-1. Camera Interface Overview

**FEATURES**

- ITU-R BT 601/656 8/16-bit mode
- DZI (Digital Zoom In) capability
- Programmable polarity of video sync signals
- Up to 4096 x 4096 pixel input (Up to 2048 x 2048 pixel input for scaling)
- Image mirror and rotation (X-axis mirror, Y-axis mirror, and 180° rotation)
- PIP and codec input image generation (RGB 16/24-bit format and YCbCr 4:2:0/4:2:2 format)

**EXTERNAL INTERFACE**

The camera interface of S3C24A0A can support the next video standards.

- ITU-R BT 601 YCbCr 8/16-bit mode
- ITU-R BT 656 YCbCr 8-bit mode

**SIGNAL DESCRIPTION**

**Table 21-1. Camera Interface Signal Description**

Name	I/O (Note)	Active	Description
XciPCLK	I	–	Pixel clock, driven by the camera processor
XciVSYNC	I	H/L	Frame sync, driven by the camera processor
XciHREF	I	H/L	Horizontal sync, driven by the camera processor
XciYDATA [7:0]	I	–	Pixel data for YcbCr in 8-bit mode or for Y in 16-bit mode, driven by the camera processor
XciCDATA [7:0]	I	–	Pixel data for CbCr in 16-bit mode, driven by the camera processor
XciCLK	O	–	Master clock to the camera processor
XciRSTn	O	H/L	Software reset or power down for the camera processor

**NOTE:** I/O direction is on the S3C24A0A side. I : input, O : output, B : bi-direction

TIMING DIAGRAM

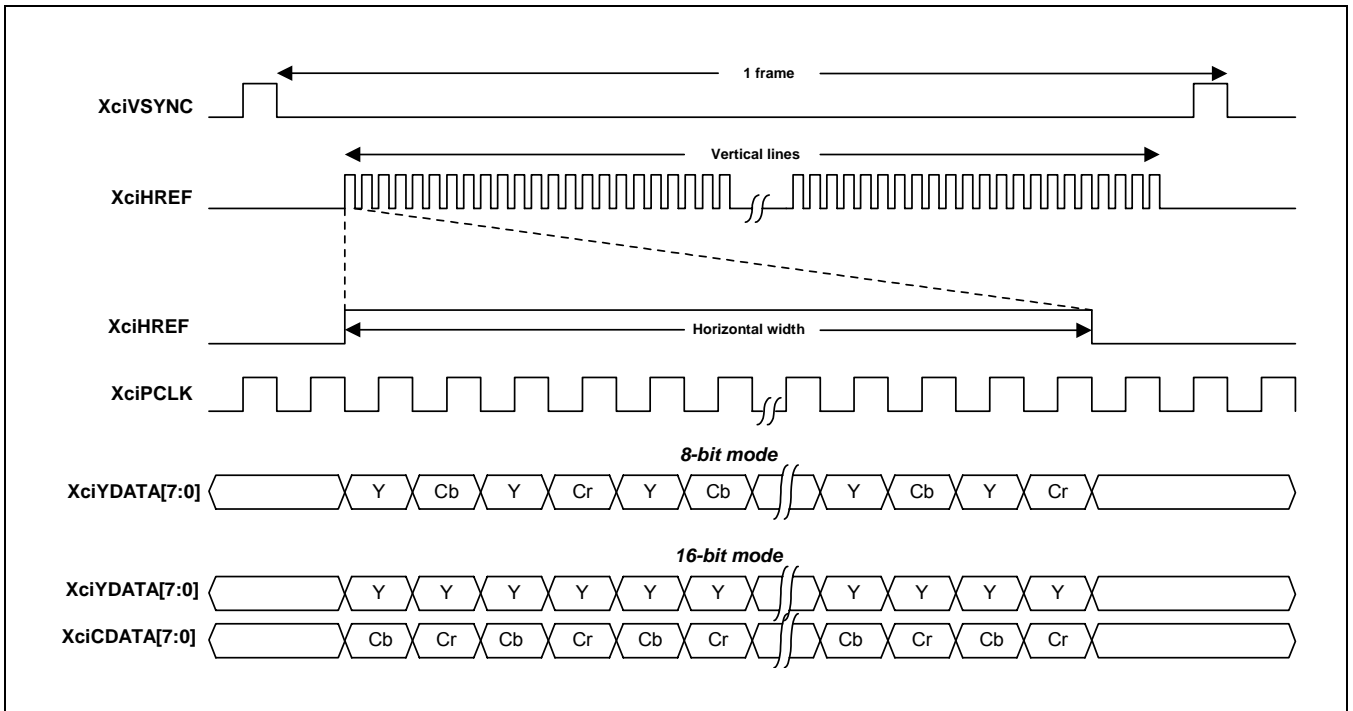

Figure 21-2. ITU-R BT 601 Input Timing Diagram

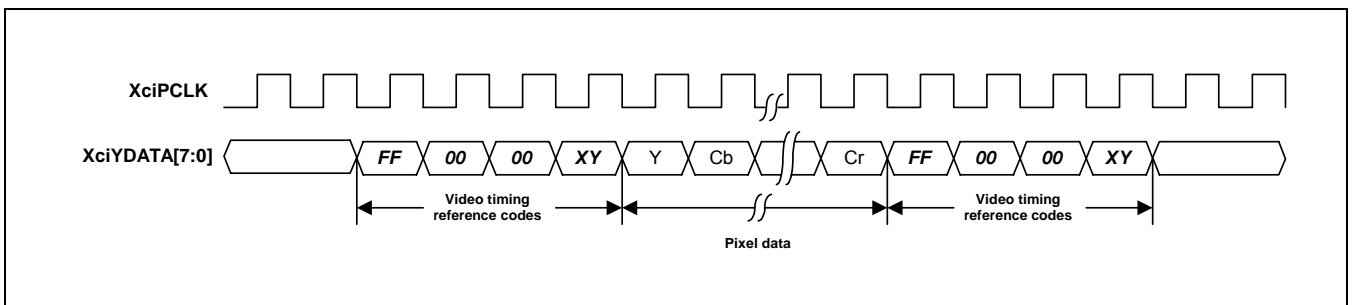

Figure 21-3. ITU-R BT 656 Input Timing Diagram

There are two timing reference signals in ITU-R BT 656 format, one is at the beginning of each video data block (start of active video, SAV) and the other is at the end of each video data block (end of active video, EAV) as shown in Figure 21-3 and Table 21-2.

**Table 21-2. Video Timing Reference Codes of ITU-656 Format**

Data Bit Number	First Word	Second Word	Third Word	Fourth Word
9 (MSB)	1	0	0	1
8	1	0	0	F
7	1	0	0	V
6	1	0	0	H
5	1	0	0	P3
4	1	0	0	P2
3	1	0	0	P1
2	1	0	0	P0
1 (Note)	1	0	0	0
0	1	0	0	0

**NOTE:** For compatibility with existing 8-bit interfaces, the values of bits D1 and D0 are not defined.

F = 0 (during field 1), 1 (during field 2)

V = 0 (elsewhere), 1 (during field blanking)

H = 0 (in SAV : Start of Active Video), 1 (in EAV : End of Active Video)

P0, P1, P2, P3 = protection bit

Camera interface logic can catch the video sync bits like H (SAV, EAV) and V (Frame Sync) after reserved data as "FF-00-00".

## EXTERNAL CONNECTION GUIDE

All input signals of camera interface should not occur inter-skewing to pixel clock line. We recommend next pin location and routing.

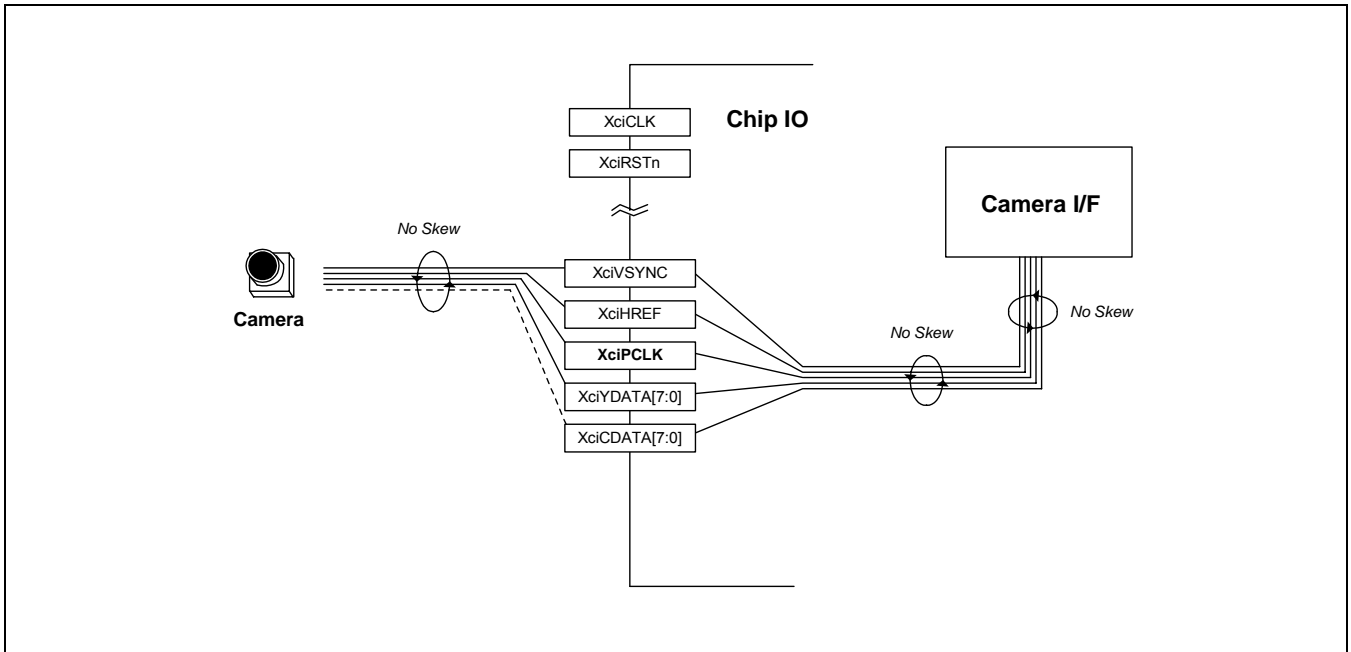

Figure 21-4. IO Connection Guide

### 8-BIT MODE

In this case, Camera data are fed into S3C24A0A through only XciYDATA[7:0]. Therefore, Signal levels of XciCDATA[7:0] are determined in appropriate value to prevent leakage current. If you connect these signals to ground, internal pull-up must be disabled at both normal and power saving mode.

### 16-BIT MODE

In this case, Camera data are fed into S3C24A0A through XciYDATA[7:0] for Y and XciCDATA[7:0] for CbCr.

## CAMERA INTERFACE OPERATION

### TWO DMA PORTS

Camera interface has two DMA ports. P-port(Preview port) and C-port(Codec port) are separated from each other on AHB bus. At the view of system bus, two ports are independent. The P-port stores the RGB image data into memory for PIP. The C-port stores the YCbCr 4:2:0 or 4:2:2 image data into memory for Codec as MPEG-4, H.263, etc. These two master ports support the variable applications like DSC (Digital Steel Camera), MPEG-4 video conference, video recording, etc. For example, P-port image can be used as preview image, and C-port image can be used as JPEG image in DSC application. Also, the P-port or C-port can be disabled separately.

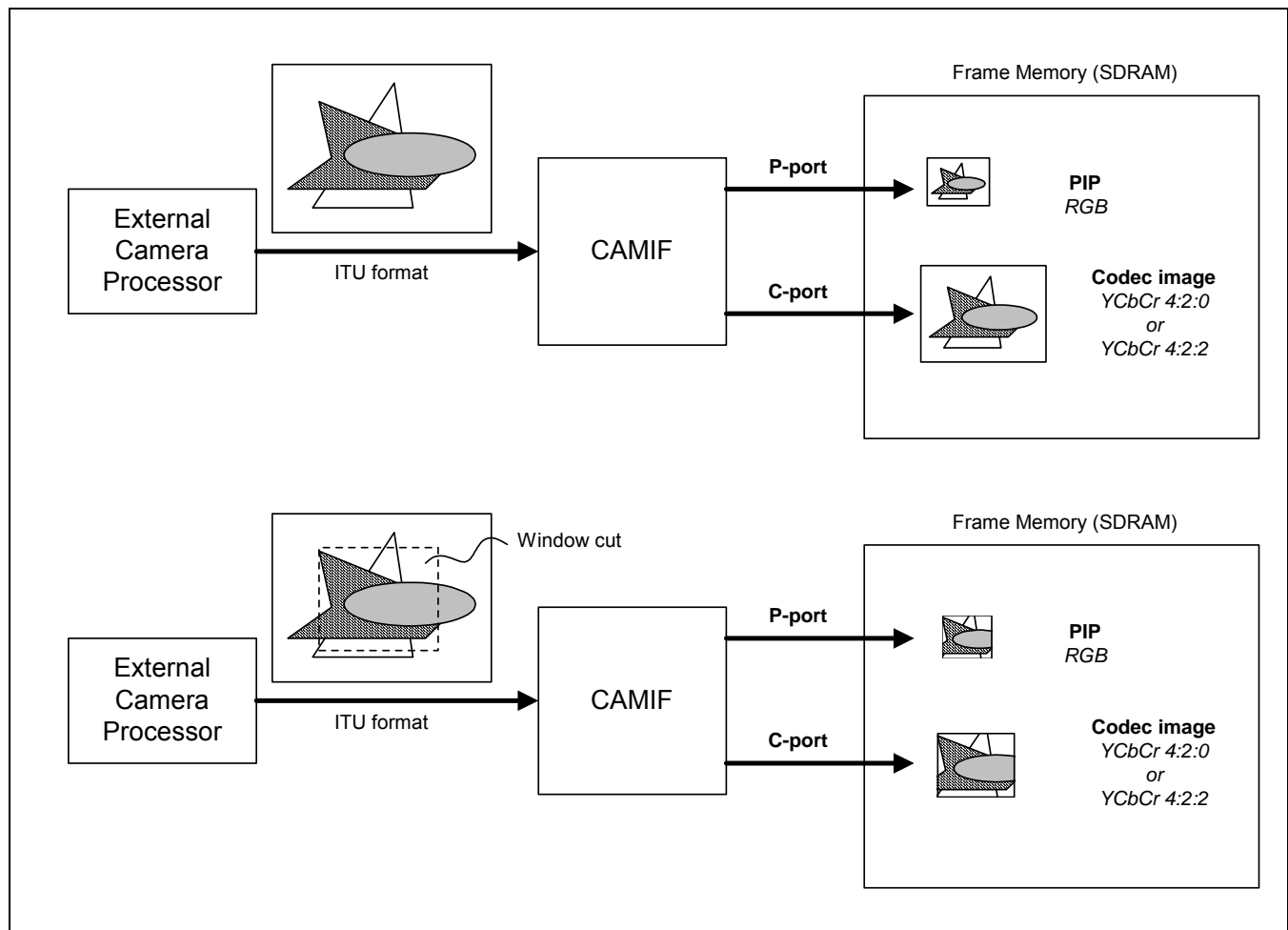
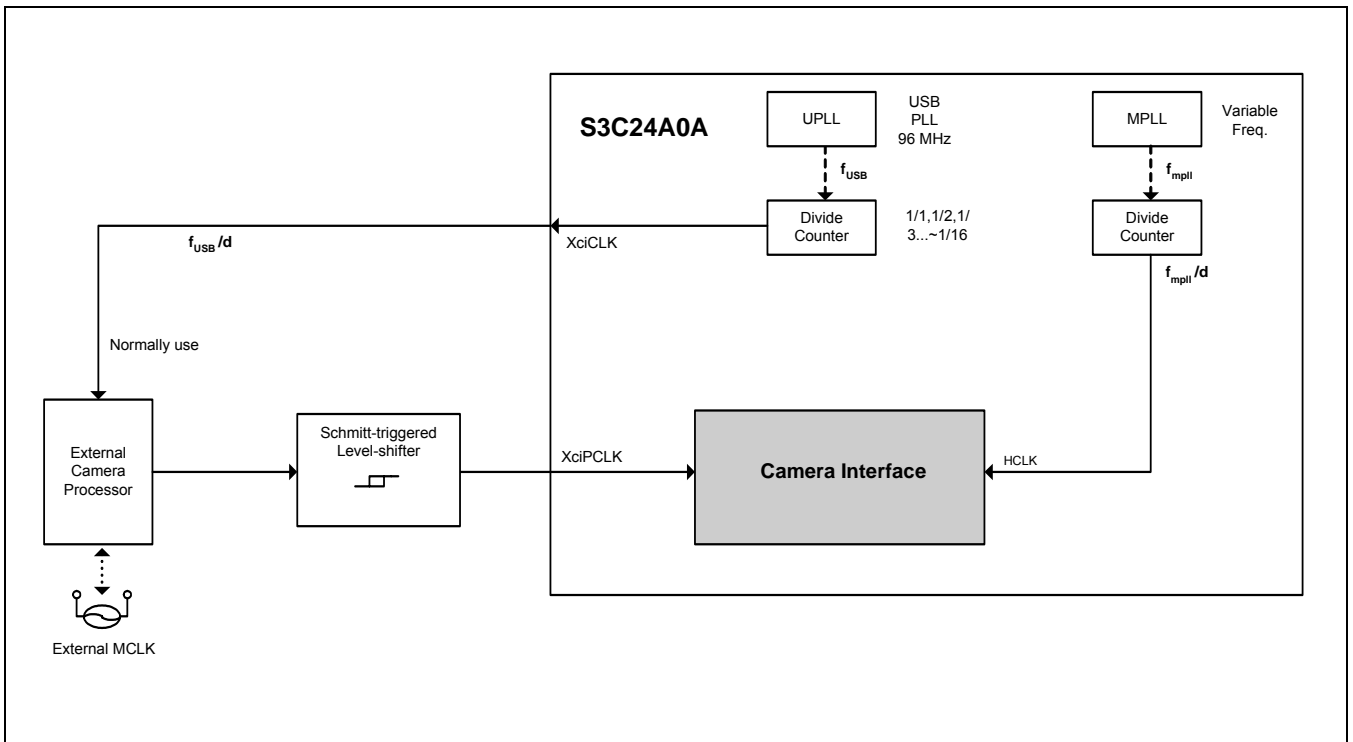

Figure 21-5. Two DMA Ports

**CLOCK DOMAIN**

Camera interface has two clock domains. The one is the system bus clock, which is HCLK. The other is the pixel clock, which is XciPCLK. *The system clock must be faster than pixel clock.* As shown in Figure 21-6, XciCLK must be divided from the fixed frequency like USB PLL clock. If external clock oscillator were used, XciCLK should be floated. The clock for internal scaler is system clock. It is not necessary that two clock domains are synchronized to each other. Other signals as XciPCLK should be connected similarly to schmitt-triggered level shifter.



**Figure 21-6. Clock Generation**

## FRAME MEMORY HIRERARCHY

Frame memories consist of four ping-pong memories for each P- and C-ports. C-port ping-pong memories have three element memories that are luminance Y, chrominance Cb, and chrominance Cr.

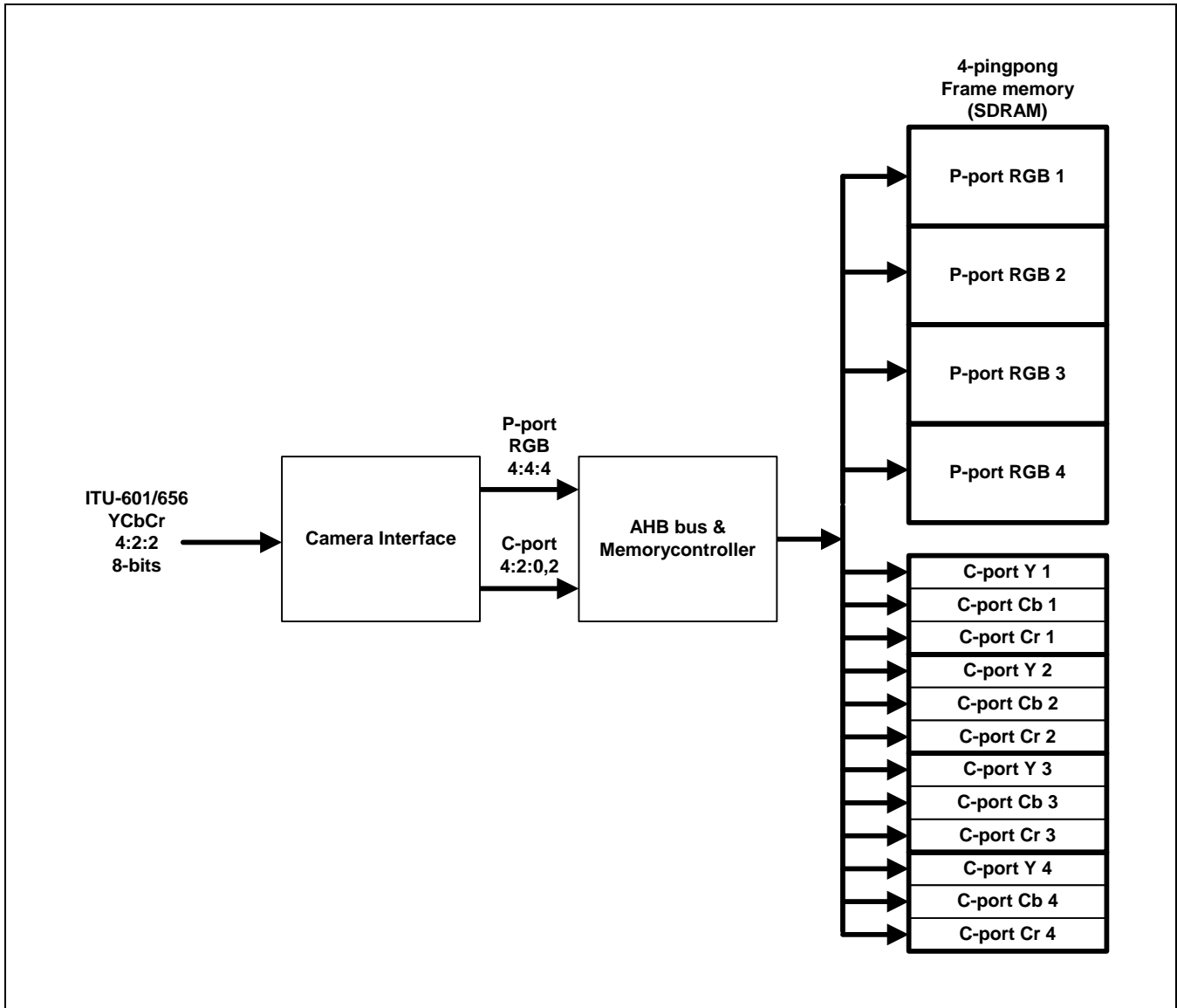

Figure 21-7. Ping-pong Memory Hierarchy



**MEMORY STORING METHOD**

The storing method to the frame memory is the little-endian method in codec path. The first entering pixels stored into LSB sides, and the last entering pixels stored into MSB sides. The carried data by AHB bus is 32-bit word. So, camera interface stores the each Y-Cb-Cr words by little endian style. For preview path, two different formats exist. One pixel (Color 1 pixel) is in one word for RGB 24-bit format. Otherwise, two pixels are in one word for RGB 16-bit format. Refer to Figure 21-8.

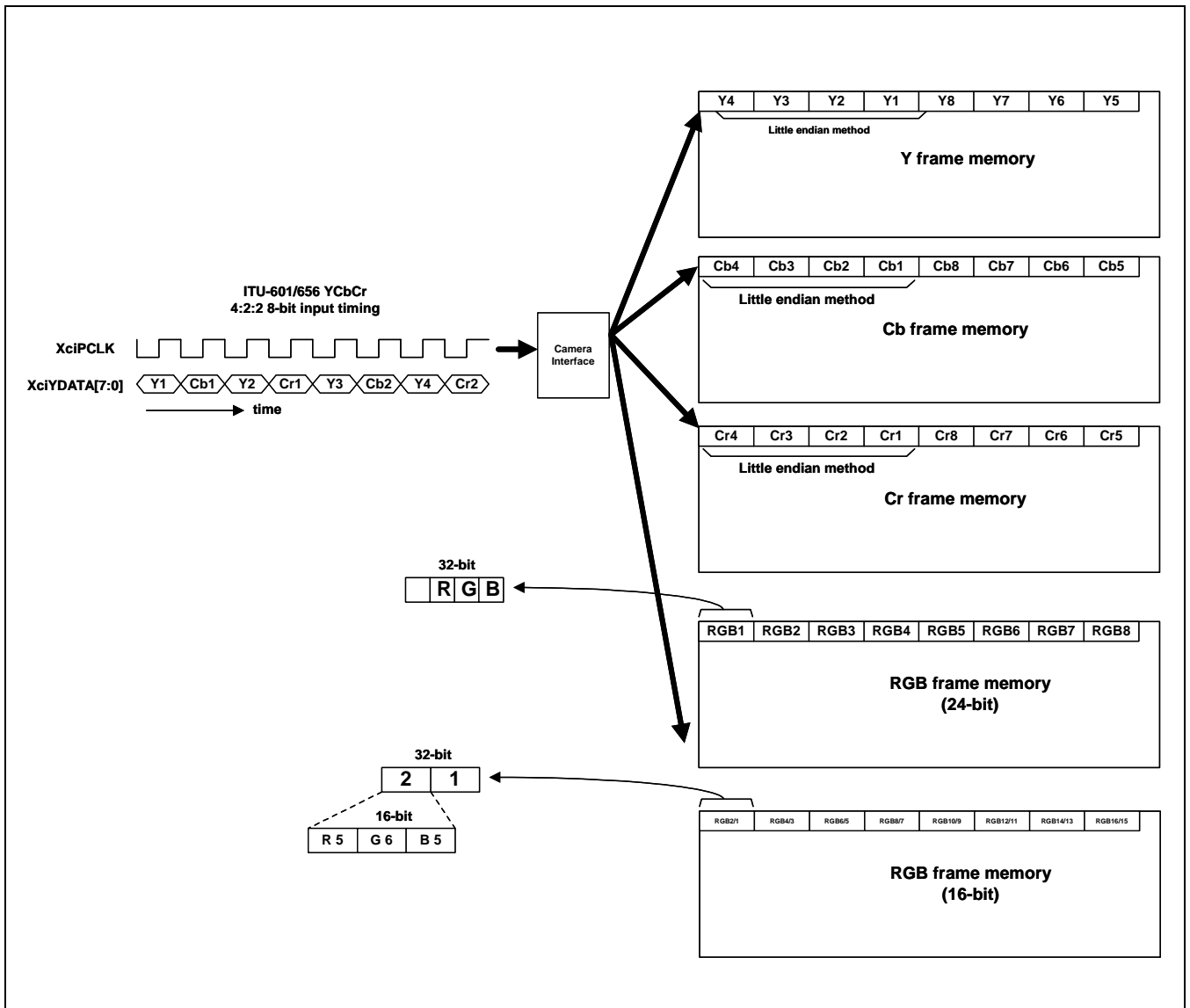

Figure 21-8. Memory Storing Style

## TIMING DIAGRAM FOR REGISTER SETTING

The first register setting for frame capture command can be occurred in anywhere of frame period. But, it is recommend to do first setting at the VSYNC "L" state. VSYNC information can be read from status SFR. All command include `ImgCptEn`, is valid at VSYNC falling edge. Be sure that except first SFR setting, all command should be programmed in ISR(Interrupt Service Routine). It is not allowed for target size information to be changed during capturing operation. However, image mirror or rotation, windowing, and Zoom In settings are allowed to change in capturing operation.

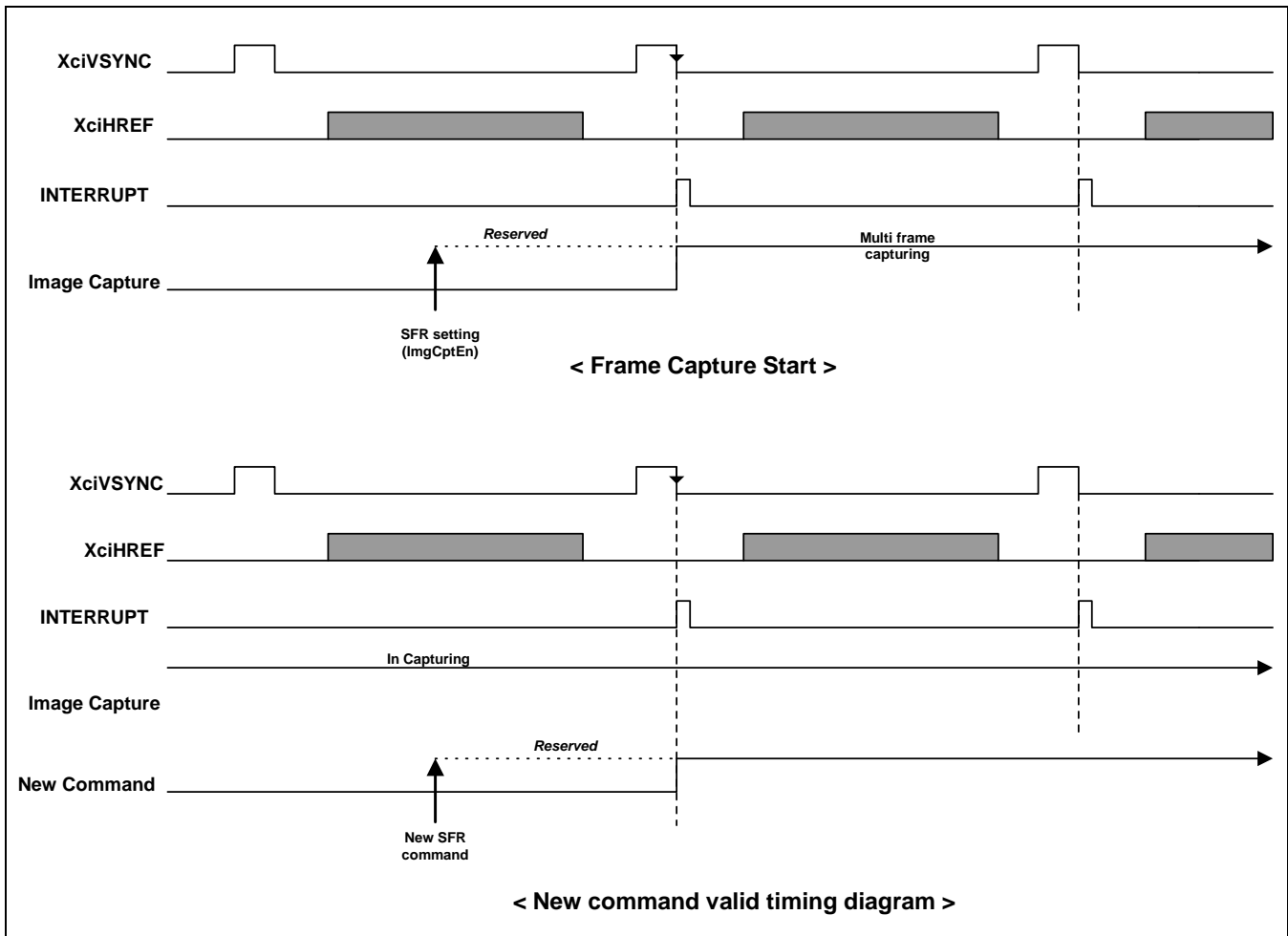

Figure 21-9. Timing Diagram for Register Setting

## NOTE

FIFO overflow of codec port will be set if codec port is not operating when preview port is operated. If you want to use codec port under this case, you should stop preview port and reset CAMIF using `SwRst` bit of `CIGCTRL` register. Then clear overflow of codec port and set special function registers that you want.

Overflow that doesn't affect normal operation will be set when camera module is turned on and 31th bit of `CISRCFMT` is '0'. We recommend that you set 31th bit of `CISRCFMT` to '1' before camera module is turned on if you use ITU-R 601 format. If overflow is set before starting capturing, please clear overflow using clearing bits of `CIWDOFST`.

**TIMING DIAGRAM FOR LAST IRQ**

IRQ except LastIRQ is generated before image capturing. Last IRQ which means capture-end can be set by following timing diagram. LastIRQEn is auto-cleared and, as mentioned, SFR setting in ISR is for next frame command. So, for adequate last IRQ, you should follow next sequence between LastIRQEn and ImgCptEn/ImgCptEn\_CoSc/ImgCptEnPrSC. It is recommended that ImgCptEn/ImgCptEn\_CoSc/ImgCptEnPrSC are set at same time and at last of SFR setting in ISR. FrameCnt which is read in ISR, means next frame count. On following diagram, last captured frame count is "1". That is, Frame 1 is the last-captured frame among frame 0~3. FrameCnt is increased by 1 at IRQ rising.

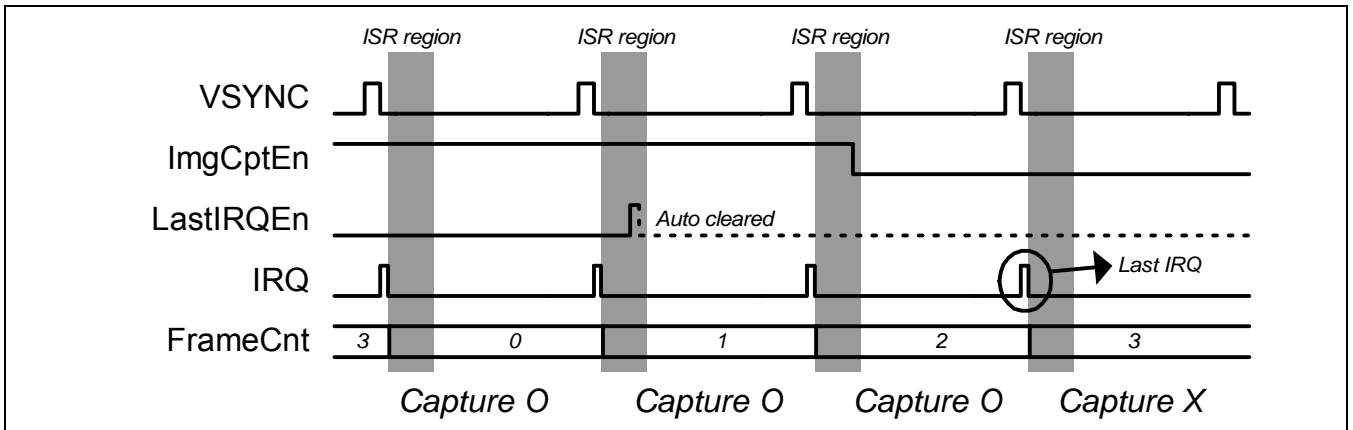

Figure 21-10. Timing Diagram for Last IRQ

**SOFTWARE INTERFACE**

Camera Interface SFR (Special Function Register)

## CAMERA INTERFACE SPECIAL REGISTERS

## SOURCE FORMAT REGISTER

Register	Address	R/W	Description	Reset Value
CISRCFMT	0x48000000	RW	Input source format	0

CISRCFMT	Bit	Description	Initial State												
ITU601_656n	[31]	1 = ITU-R BT.601 YCbCr 8/16-bit mode enable 0 = ITU-R BT.656 YCbCr 8-bit mode enable	0												
UVOffset	[30]	Cb,Cr value offset control. 1 = +128 0 = +0 (normally used)	0												
In16bit	[29]	ITU-R BT 601 YCbCr 16-bit mode enable	0												
SourceHsize	[28:16]	Source horizontal pixel number (must be 8's multiple)	0												
Order422	[15:14]	Input YCbCr order inform for input 8/16-bit mode <table border="1" data-bbox="496 927 1238 1149"> <thead> <tr> <th>8-bit mode (In16bit = 0)</th> <th>16-bit mode (In16bit = 1)</th> </tr> </thead> <tbody> <tr> <td>00 : YcbYCr</td> <td>00 : Y Y Y Y</td> </tr> <tr> <td>01 : YcrYCb</td> <td>    CbCrCbCr</td> </tr> <tr> <td>10 : CbYCrY</td> <td>01 : Y Y Y Y</td> </tr> <tr> <td>11 : CrYCbY</td> <td>    CrCbCrCb</td> </tr> <tr> <td></td> <td>Others : Forbidden</td> </tr> </tbody> </table>	8-bit mode (In16bit = 0)	16-bit mode (In16bit = 1)	00 : YcbYCr	00 : Y Y Y Y	01 : YcrYCb	CbCrCbCr	10 : CbYCrY	01 : Y Y Y Y	11 : CrYCbY	CrCbCrCb		Others : Forbidden	0
8-bit mode (In16bit = 0)	16-bit mode (In16bit = 1)														
00 : YcbYCr	00 : Y Y Y Y														
01 : YcrYCb	CbCrCbCr														
10 : CbYCrY	01 : Y Y Y Y														
11 : CrYCbY	CrCbCrCb														
	Others : Forbidden														
SourceVsize	[12:0]	Source vertical pixel number (must be 16's multiple for JPEG DCT.)	0												

**WINDOW OPTION REGISTER**

Register	Address	R/W	Description	Reset Value
CIWDOFST	0x48000004	RW	Window offset register	0

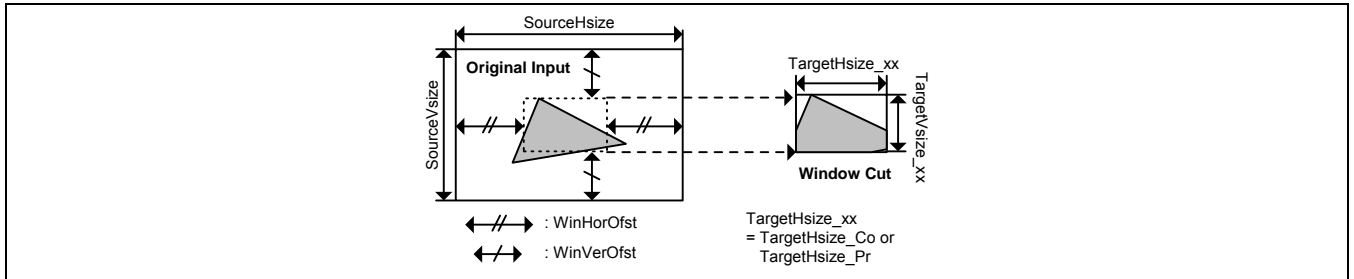

**Figure 21-11. Window Offset Scheme**

CIWDOFST	Bit	Description	Initial State
WinOfsEn	[31]	1 = Window offset enable 0 = No offset	0
ClrOvCoFiY	[30]	1 = Clear the overflow indication flag of input CODEC FIFO Y 0 = Normal	0
WinHorOfst	[26:16]	Window horizontal offset by pixel unit. (The size of offset must be multiple of 8)	0
ClrOvCoFiCb	[15]	1 = Clear the overflow indication flag of input CODEC FIFO Cb 0 = Normal	0
ClrOvCoFiCr	[14]	1 = Clear the overflow indication flag of input CODEC FIFO Cr 0 = Normal	0
ClrOvPrFiCb	[13]	1 = Clear the overflow indication flag of input PREVIEW FIFO Cb 0 = Normal	0
ClrOvPrFiCr	[12]	1 = Clear the overflow indication flag of input PREVIEW FIFO Cr 0 = Normal	0
WinVerOfst	[10:0]	Window vertical offset by pixel unit	0

Clear bits should be set by zero after clearing the flags.



## GLOBAL CONTROL REGISTER

Register	Address	R/W	Description	Reset Value
CIGCTRL	0x48000008	RW	Global control register	0x20000000

CIGCTRL	Bit	Description	Initial State
SwRst	[31]	Camera interface software reset	0
CamRst	[30]	External camera processor reset or power down control	0
Reserved	[29]	Should be '1'.	1
TestPattern	[28:27]	This register should be set at only ITU-T 601 8-bit mode. Not allowed with input 16-bit mode or ITU-T 656 mode. (max. 1280 X 1024) 00 = External camera processor input (normal) 01 = Color bar test pattern 10 = Horizontal increment test pattern 11 = Vertical increment test pattern	0
InvPolPCLK	[26]	1 = Inverse the polarity of XciPCLK 0 = Normal (Camera data is fetched at rising edge of XciPCLK)	0
InvPolVSYNC	[25]	1 = Inverse the polarity of XciVSYNC 0 = Normal	0
InvPolHREF	[24]	1 = Inverse the polarity of XciHREF 0 = Normal	0

## Y1 START ADDRESS REGISTER

Register	Address	R/W	Description	Reset Value
CICOYSA1	0x48000018	RW	1 <sup>st</sup> Y frame start address for codec DMA	0

CICOYSA1	Bit	Description	Initial State
CICOYSA1	[31:0]	1 <sup>st</sup> Y frame start address for codec DMA	0

## Y2 START ADDRESS REGISTER

Register	Address	R/W	Description	Reset Value
CICOYSA2	0x4800001c	RW	2 <sup>nd</sup> Y frame start address for codec DMA	0

CICOYSA2	Bit	Description	Initial State
CICOYSA2	[31:0]	2 <sup>nd</sup> Y frame start address for codec DMA	0

**Y3 START ADDRESS REGISTER**

Register	Address	R/W	Description	Reset Value
CICOYSA3	0x48000020	RW	3 <sup>rd</sup> Y frame start address for codec DMA	0

CICOYSA3	Bit	Description	Initial State
CICOYSA3	[31:0]	3 <sup>rd</sup> Y frame start address for codec DMA	0

**Y4 START ADDRESS REGISTER**

Register	Address	R/W	Description	Reset Value
CICOYSA4	0x48000024	RW	4 <sup>th</sup> Y frame start address for codec DMA	0

CICOYSA4	Bit	Description	Initial State
CICOYSA4	[31:0]	4 <sup>th</sup> Y frame start address for codec DMA	0

**CB1 START ADDRESS REGISTER**

Register	Address	R/W	Description	Reset Value
CICOCBSA1	0x48000028	RW	1 <sup>st</sup> Cb frame start address for codec DMA	0

CICOCBSA1	Bit	Description	Initial State
CICOCBSA1	[31:0]	1 <sup>st</sup> Cb frame start address for codec DMA	0

**CB2 START ADDRESS REGISTER**

Register	Address	R/W	Description	Reset Value
CICOCBSA2	0x4800002c	RW	2 <sup>nd</sup> Cb frame start address for codec DMA	0

CICOCBSA2	Bit	Description	Initial State
CICOCBSA2	[31:0]	2 <sup>nd</sup> Cb frame start address for codec DMA	0



**CB3 START ADDRESS REGISTER**

Register	Address	R/W	Description	Reset Value
CICOCBSA3	0x48000030	RW	3 <sup>rd</sup> Cb frame start address for codec DMA	0

CICOCBSA3	Bit	Description	Initial State
CICOCBSA3	[31:0]	3 <sup>rd</sup> Cb frame start address for codec DMA	0

**CB4 START ADDRESS REGISTER**

Register	Address	R/W	Description	Reset Value
CICOCBSA4	0x48000034	RW	4 <sup>th</sup> Cb frame start address for codec DMA	0

CICOCBSA4	Bit	Description	Initial State
CICOCBSA4	[31:0]	4 <sup>th</sup> Cb frame start address for codec DMA	0

**CR1 START ADDRESS REGISTER**

Register	Address	R/W	Description	Reset Value
CICOCSRSA1	0x48000038	RW	1 <sup>st</sup> Cr frame start address for codec DMA	0

CICOCSRSA1	Bit	Description	Initial State
CICOCSRSA1	[31:0]	1 <sup>st</sup> Cr frame start address for codec DMA	0

**CR2 START ADDRESS REGISTER**

Register	Address	R/W	Description	Reset Value
CICOCSRSA2	0x4800003c	RW	2 <sup>nd</sup> Cr frame start address for codec DMA	0

CICOCSRSA2	Bit	Description	Initial State
CICOCSRSA2	[31:0]	2 <sup>nd</sup> Cr frame start address for codec DMA	0



**CR3 START ADDRESS REGISTER**

Register	Address	R/W	Description	Reset Value
CICOCSA3	0x48000040	RW	3 <sup>rd</sup> Cr frame start address for codec DMA	0

CICOCSA3	Bit	Description	Initial State
CICOCSA3	[31:0]	3 <sup>rd</sup> Cr frame start address for codec DMA	0

**CR4 START ADDRESS REGISTER**

Register	Address	R/W	Description	Reset Value
CICOCSA4	0x48000044	RW	4 <sup>th</sup> Cr frame start address for codec DMA	0

CICOCSA4	Bit	Description	Initial State
CICOCSA4	[31:0]	4 <sup>th</sup> Cr frame start address for codec DMA	0

## CODEC TARGET FORMAT REGISTER

Register	Address	R/W	Description	Reset Value
CICOTRGFMT	0x48000048	RW	Target image format of codec DMA	0

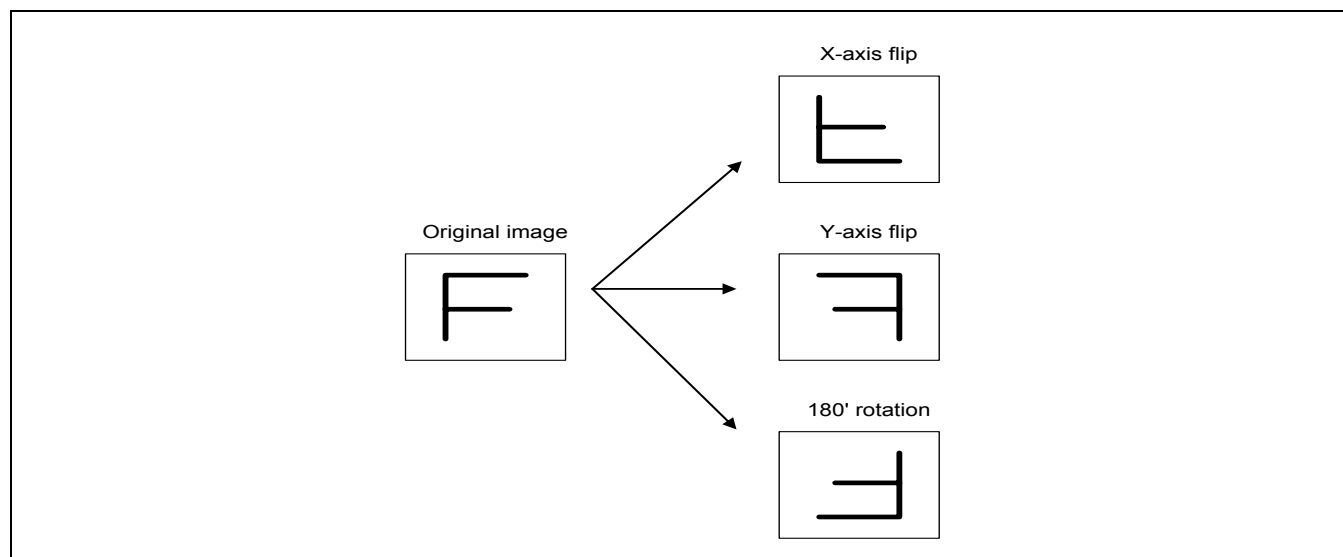

Figure 21-12. Image Mirror and Rotation

CICOTRGFMT	Bit	Description	Initial State
In422_Co	[31]	1 = YCbCr 4:2:2 codec scaler input image format. 0 = YCbCr 4:2:0 codec scaler input image format. In this case, horizontal line decimation is performed before codec scaler. (normal)	0
Out422_Co	[30]	1 = YCbCr 4:2:2 codec scaler output image format. This mode is mainly for S/W JPEG. 0 = YCbCr 4:2:0 codec scaler output image format. This mode is mainly for MPEG-4 codec and H/W JPEG DCT. (normal)	0
TargetHsize_Co	[28:16]	Horizontal pixel number of target image for codec DMA (16's multiple)	0
FlipMd_Co	[15:14]	Image mirror and rotation for codec DMA 00 = Normal 01 = X-axis mirror 10 = Y-axis mirror 11 = 180° rotation	0
TargetVsize_Co	[12:0]	Vertical pixel number of target image for codec DMA (must be 16's multiple for JPEG DCT.)	0

## CODEC DMA CONTROL REGISTER

Register	Address	R/W	Description	Reset Value
CICOCTRL	0x4800004c	RW	Codec DMA control	0

CICOCTRL	Bit	Description	Initial State
Yburst1_Co	[23:19]	Main burst length for codec Y frames	0
Yburst2_Co	[18:14]	Remained burst length for codec Y frames	0
Cburst1_Co	[13:9]	Main burst length for codec Cb/Cr frames	0
Cburst2_Co	[8:4]	Remained burst length for codec Cb/Cr frames	0
LastIRQEn_Co	[2]	1 = Enable last IRQ at the end of frame capture (It is recommended to check the done signal of capturing image for JPEG.) 0 = Normal	0

All burst lengths should be one of the 2,4,8,16.

Example 1. Target image size: QCIF (horizontal Y width = 176)

$$176 / 4 = 44 \text{ word.}$$

$$44 \% 8 = 4 \rightarrow \text{main burst} = 8, \text{ remained burst} = 4$$

Example 2. Target image size: VGA (horizontal Y width = 640)

$$640 / 4 = 160 \text{ word.}$$

$$160 \% 16 = 0 \rightarrow \text{main burst} = 16, \text{ remained burst} = 16$$

Example 3. Target image size: QCIF (horizontal C width = 88)

$$88 / 4 = 22 \text{ word.}$$

$$22 \% 4 = 2 \rightarrow \text{main burst} = 4, \text{ remained burst} = 2 \text{ (HTRANS==INCR)}$$

## REGISTER SETTING GUIDE FOR CODEC SCALER AND PREVIEW SCALER

SRC\_Width and DST\_Width satisfy the following constraints. In SRC\_Width case, the number of horizontal pixel can be represented to the power of 8. In DST\_Width case, the number of horizontal pixel can be represented  $kn$  where  $n = 1,2,3, \dots$  and  $k = 2/4/16$  for 24bpp RGB/16bpp RGB/YCbCr image, respectively. TargetHsize should not be larger than SourceHsize. Similarly, TargetVsize should not be larger than SourceVsize.



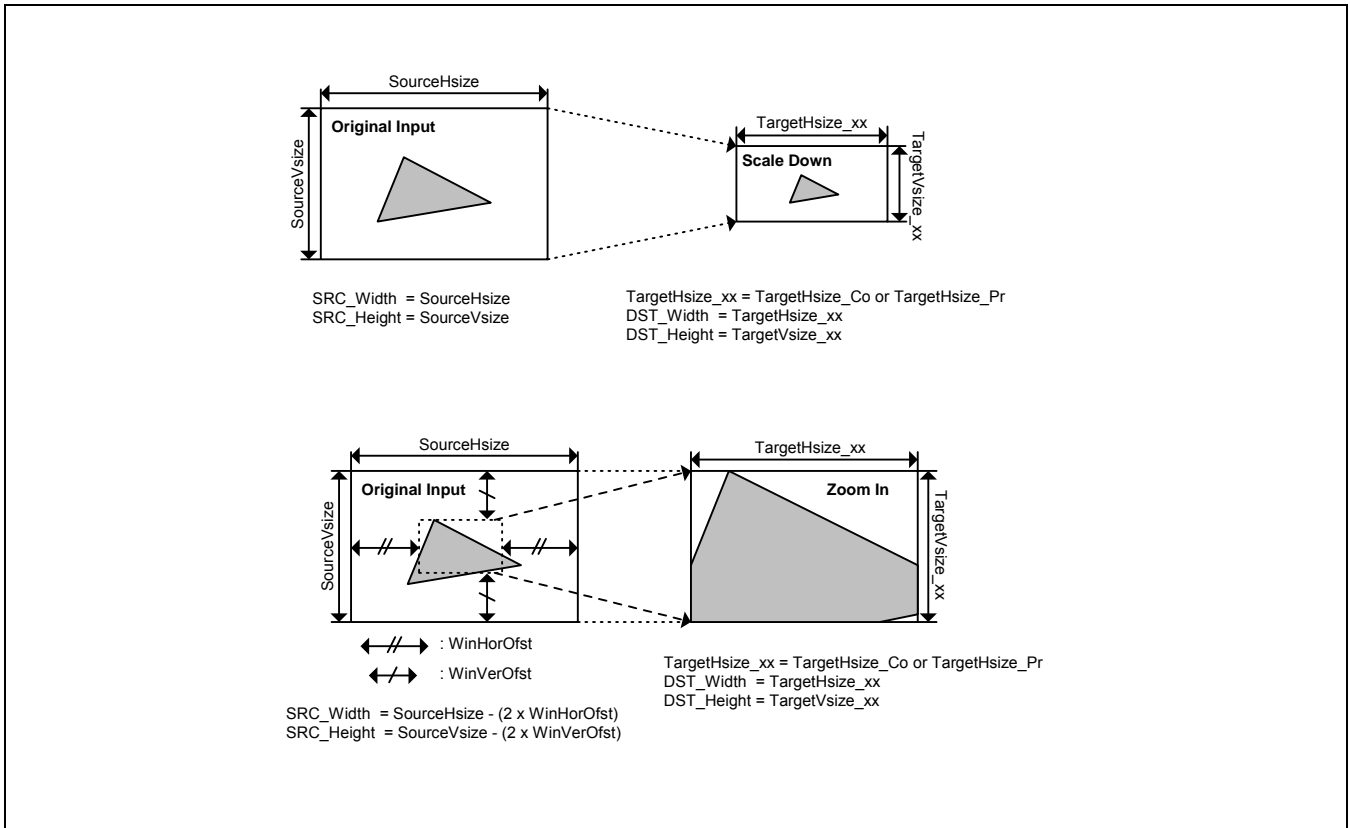

Figure 21-13. Scaling scheme

The other control registers of pre-scaled image size, pre-scale ratio, pre-scale shift ratio and main scale ratio are defined according to the following equations.

```
If ( SRC_Width >= 64 × DST_Width ) { Exit(-1); /* Out Of Horizontal Scale Range */ }
else if ( SRC_Width >= 32 × DST_Width ) { PreHorRatio_xx = 32; H_Shift = 5; }
else if ( SRC_Width >= 16 × DST_Width ) { PreHorRatio_xx = 16; H_Shift = 4; }
else if ( SRC_Width >= 8 × DST_Width ) { PreHorRatio_xx = 8; H_Shift = 3; }
else if ( SRC_Width >= 4 × DST_Width ) { PreHorRatio_xx = 4; H_Shift = 2; }
else if ( SRC_Width >= 2 × DST_Width ) { PreHorRatio_xx = 2; H_Shift = 1; }
else { PreHorRatio_xx = 1; H_Shift = 0; }
```

```
PreDstWidth_xx = SRC_Width / PreHorRatio_xx;
MainHorRatio_xx = ( SRC_Width << 8 ) / ( DST_Width << H_Shift);
```

```
If ( SRC_Height >= 64 × DST_Height ) { Exit(-1); /* Out Of Vertical Scale Range */ }
else if ( SRC_Height >= 32 × DST_Height ) { PreVerRatio_xx = 32; V_Shift = 5; }
else if ( SRC_Height >= 16 × DST_Height ) { PreVerRatio_xx = 16; V_Shift = 4; }
else if ( SRC_Height >= 8 × DST_Height ) { PreVerRatio_xx = 8; V_Shift = 3; }
else if ( SRC_Height >= 4 × DST_Height ) { PreVerRatio_xx = 4; V_Shift = 2; }
else if ( SRC_Height >= 2 × DST_Height ) { PreVerRatio_xx = 2; V_Shift = 1; }
else { PreVerRatio_xx = 1; V_Shift = 0; }
```

```
PreDstHeight_xx = SRC_Height / PreVerRatio_xx;
MainVerRatio_xx = ( SRC_Height << 8 ) / ( DST_Height << V_Shift);
SHfactor_xx = 10 - ( H_Shift + V_Shift);
```

#### NOTE

In preview path, Pre-scaled H\_width must be the less than 640. (The maximum size of preview path horizontal line buffer is 640.)



**CODEC DMA TARGET AREA REGISTER**

Register	Address	R/W	Description	Reset Value
CICOTAREA	0x4800005c	RW	Codec pre-scaler destination format	0

CICOTAREA	Bit	Description	Initial State
CICOTAREA	[25:0]	Target area for codec DMA = Target H size x Target V size	0

**CODEC STATUS REGISTER**

Register	Address	R/W	Description	Reset Value
CICOSTATUS	0x48000064	R	Codec path status	0

CICOSTATUS	Bit	Description	Initial State
OvFiY_Co	[31]	Overflow state of codec FIFO Y	0
OvFiCb_Co	[30]	Overflow state of codec FIFO Cb	0
OvFiCr_Co	[29]	Overflow state of codec FIFO Cr	0
VSYNC	[28]	Camera VSYNC (This bit can be referred by CPU for first SFR setting after external camera muxing. And, it can be seen in the ITU-R BT 656 mode) 1 = Blank, 0 = Field	0
FrameCnt_Co	[27:26]	Frame count of codec DMA (This counter value means the next frame number)	0
WinOfstEn_Co	[25]	Window offset enable status	0
FlipMd_Co	[24:23]	Flip mode of codec DMA	0
ImgCptEn_CamIf	[22]	Image capture enable of camera interface	0
ImgCptEn_CoSC	[21]	Image capture enable of codec path	0
VSYNC_E	[20]	Status of signal level of XciVSYNC	x

**RGB1 START ADDRESS REGISTER**

Register	Address	R/W	Description	Reset Value
CIPRCLRSA1	0x4800006c	RW	1 <sup>st</sup> RGB frame start address for preview DMA	0

CIPRCLRSA1	Bit	Description	Initial State
CIPRCLRSA1	[31:0]	1 <sup>st</sup> RGB frame start address for preview DMA	0

**RGB2 START ADDRESS REGISTER**

Register	Address	R/W	Description	Reset Value
CIPRCLRSA2	0x48000070	RW	2 <sup>nd</sup> RGB frame start address for preview DMA	0

CIPRCLRSA2	Bit	Description	Initial State
CIPRCLRSA2	[31:0]	2 <sup>nd</sup> RGB frame start address for preview DMA	0

**RGB3 START ADDRESS REGISTER**

Register	Address	R/W	Description	Reset Value
CIPRCLRSA3	0x48000074	RW	3 <sup>rd</sup> RGB frame start address for preview DMA	0

CIPRCLRSA3	Bit	Description	Initial State
CIPRCLRSA3	[31:0]	3 <sup>rd</sup> RGB frame start address for preview DMA	0

**RGB4 START ADDRESS REGISTER**

Register	Address	R/W	Description	Reset Value
CIPRCLRSA4	0x48000078	RW	4 <sup>th</sup> RGB frame start address for preview DMA	0

CIPRCLRSA4	Bit	Description	Initial State
CIPRCLRSA4	[31:0]	4 <sup>th</sup> RGB frame start address for preview DMA	0



**PREVIEW TARGET FORMAT REGISTER**

Register	Address	R/W	Description	Reset Value
CIPRTRGFMT	0x4800007c	RW	Target image format of preview DMA	0

CIPRTRGFMT	Bit	Description	Initial State
TargetHsize_Pr	[28:16]	Horizontal pixel number of target image for preview DMA . 16bpp RGB = 4n(n=1,2,3, ...) 24bpp RGB = 2n(n=1,2,3, ...)	0
FlipMd_Pr	[15:14]	Image mirror and rotation for preview DMA 00 = Normal 01 = x-axis mirror 10 = y-axis mirror 11 = 180° rotation	0
TargetVsize_Pr	[12:0]	Vertical pixel number of target image for preview DMA	0

**PREVIEW DMA CONTROL REGISTER**

Register	Address	R/W	Description	Reset Value
CIPRCTRL	0x48000080	RW	Preview DMA control related	0

CIPRCTRL	Bit	Description	Initial State
RGBburst1_Pr	[23:19]	Main burst length for preview RGB frames	0
RGBburst2_Pr	[18:14]	Remained burst length for preview RGB frames	0
LastIRQEn_Pr	[2]	1 = Enable last IRQ at the end of frame capture 0 = Normal	0

All burst lengths must be one of the 2, 4, 8, 16.

Example 1. Target image size : QCIF for RGB 32-bit format (horizontal width = 176 pixels. 1 pixel = 1 word)  
176 pixel = 176 word.  
176 % 16 = 0 → main burst = 16, remained burst = 16

Example 2. Target image size : VGA for RGB 16-bit format (horizontal width = 640 pixels. 2 pixel = 1 word)  
640 / 2 = 320 word.  
160 % 16 = 0 → main burst = 16, remained burst = 16

**NOTE**

Preview path contains 640 pixel line buffer.(Codec path contains 2048 pixel line buffer) So, upper 1280 pixels, input images must be pre-scaled by over 1/2 for capturing valid preview image.



**PREVIEW PRE-SCALER CONTROL REGISTER 1**

Register	Address	R/W	Description	Reset Value
CIPRSCPRERATIO	0x48000084	RW	Preview pre-scaler ratio control	0

CIPRSCPRERATIO	Bit	Description	Initial State
SHfactor_Pr	[31:28]	Shift factor for preview pre-scaler	0
PreHorRatio_Pr	[22:16]	Horizontal ratio of preview pre-scaler	0
PreVerRatio_Pr	[6:0]	Vertical ratio of preview pre-scaler	0

**PREVIEW PRE-SCALER CONTROL REGISTER 2**

Register	Address	R/W	Description	Reset Value
CIPRSCPREDST	0x48000088	RW	Preview pre-scaler destination format	0

CIPRSCPREDST	Bit	Description	Initial State
PreDstWidth_Pr	[27:16]	Destination width for preview pre-scaler	0
PreDstHeight_Pr	[11:0]	Destination height for preview pre-scaler	0

**PREVIEW MAIN-SCALER CONTROL REGISTER**

Register	Address	R/W	Description	Reset Value
CIPRSCCTRL	0x4800008c	RW	Preview main-scaler control	0

CIPRSCCTRL	Bit	Description	Initial State
Sample_Pr	[31]	Sampling method for format conversion. (normally 1)	0
RGBformat_Pr	[30]	1 = 24-bit RGB ,                      0 = 16-bit RGB	0
ScaleUpDown_Pr	[29:28]	Scale up/down flag for preview scaler(In 1:1 scale ratio, this bit should be "1") 00 = Down                                      11 = Up	00
MainHorRatio_Pr	[24:16]	Horizontal scale ratio for preview main-scaler	0
PrScalerStart	[15]	Preview scaler start	0
MainVerRatio_Pr	[8:0]	Vertical scale ratio for preview main-scaler	0

**PREVIEW DMA TARGET AREA REGISTER**

Register	Address	R/W	Description	Reset Value
CIPRTAREA	0x48000090	RW	Preview pre-scaler destination format	0

CIPRTAREA	Bit	Description	Initial State
CIPRTAREA	[25:0]	Target area for preview DMA = Target H size x Target V size	0

**PREVIEW STATUS REGISTER**

Register	Address	R/W	Description	Reset Value
CIPRSTATUS	0x48000098	R	Preview path status	0

CIPRSTATUS	Bit	Description	Initial State
OvFiCb_Pr	[31]	Overflow state of preview FIFO Cb	0
OvFiCr_Pr	[30]	Overflow state of preview FIFO Cr	0
FrameCnt_Pr	[27:26]	Frame count of preview DMA	0
FlipMd_Pr	[24:23]	Flip mode of preview DMA	0
ImgCptEn_PrSC	[21]	Image capture enable of preview path	0

**IMAGE CAPTURE ENABLE REGISTER**

Register	Address	R/W	Description	Reset Value
CIIMGCPT	0x480000a0	RW	Image capture enable command	0

CIIMGCPT	Bit	Description	Initial State
ImgCptEn	[31]	camera interface global capture enable	0
ImgCptEn_CoSc	[30]	capture enable for codec scaler. This bit must be zero in scaler-bypass mode.	0
ImgCptEn_PrSc	[29]	capture enable for preview scaler. This bit must be zero in scaler-bypass mode.	0

**NOTE:** This register must be set at last.

## NOTES

---

21-28

Preliminary product information describe products that are in development, for which full characterization data and associated errata are not yet available. Specifications and information herein are subject to change without notice.



ELECTRONICS

# 22

## MPEG-4 VIDEO CODEC

### OVERVIEW

MPEG-4 is an ISO/IEC standard developed by MPEG (Moving Picture Experts Group). MPEG-4 video aims at providing standardized core technologies allowing efficient storage, transmission and manipulation of video data in multimedia environments. MPEG-4 video codec of S3C24A0A provides high performance solution and lower the processing load of embedded processor core. The processing clock for DCT/quantization and motion estimation can be controlled by embedded processor core to reduce the power consumption.

### FEATURE

- ISO/IEC MPEG-4 Simple Profile @ Level 3 / ITU-T H.263 Base Line
- AMBA AHB Interface
- Real-time Encoding / Decoding
- Scalable image size : M x N macro-blocks up to 2048x2048
- Hardware Accelerator for Motion Estimation, Motion Compensation, DCT/Quantization and VLC/VLD
- Unrestricted Mode & Advanced Prediction Mode (4MV)
- Half-pel Search
- Programmable Processing Clock in DCT/Quantization and Motion Estimation: HCLK ~ HCLK/30

## BLOCK DIAGRAM

Figure 22-1 shows the functional block diagram of S3C24A0A MPEG-4 Video CODEC. This CODEC consists of four parts, i.e., DCT/Quantization, Motion Compensation, Motion Estimation and VLX(VLC/VLD).

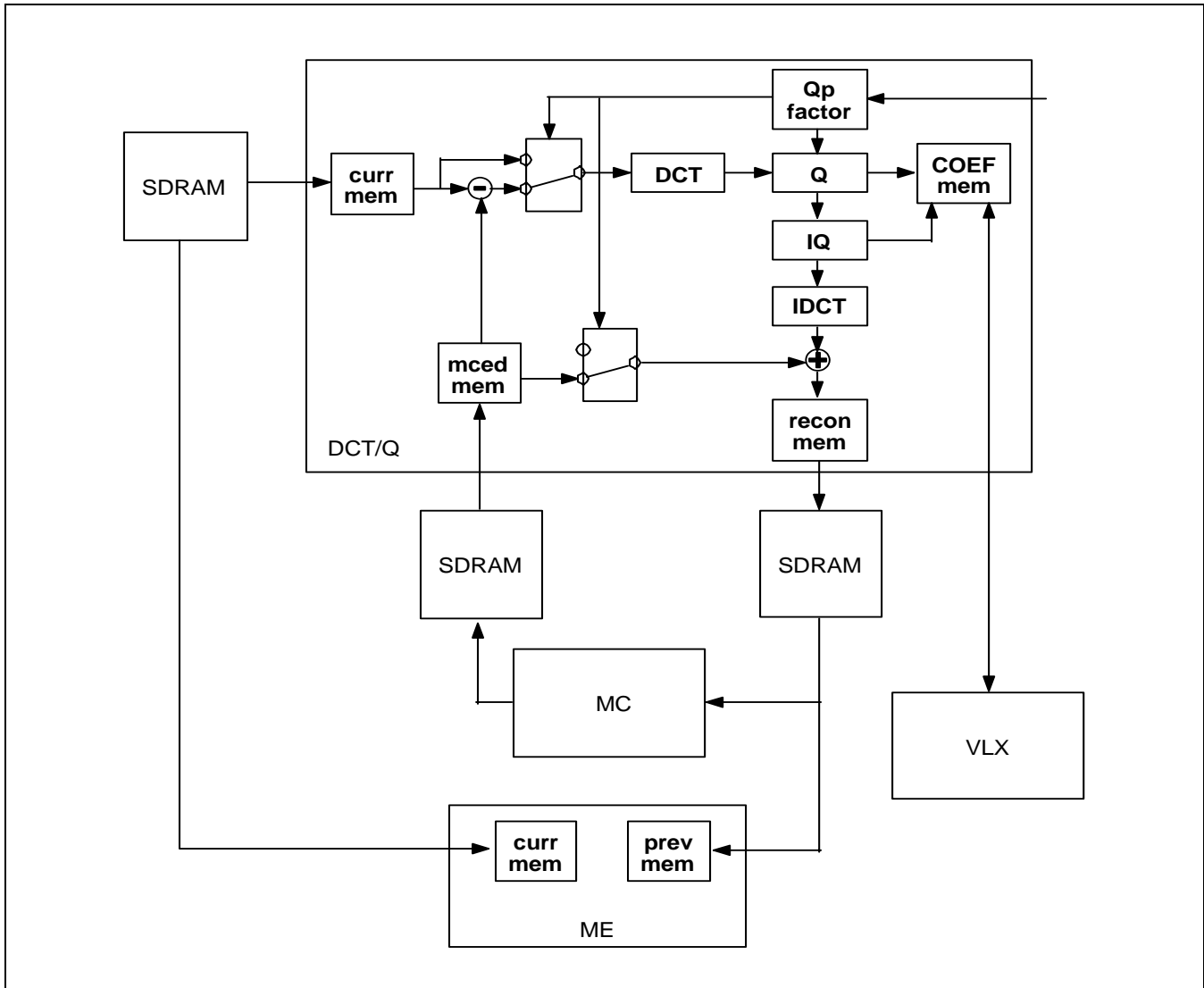

Figure 22-1. MPEG-4 Video CODEC Block Diagram

# 23

## MPEG-4 MOTION ESTIMATION

### OVERVIEW

The MPEG-4 motion estimation block is a part of MPEG-4 Video CODEC. Motion estimation is an essential part in standard video coder such as H.26x, MPEG-1, MPEG-2 and MPEG-4. By removing temporal redundancies existing in adjacent frames Advanced MRMCS (Multi-Resolution search using Multiple Candidates and Spatial correlation of motion field) algorithm is applied and it is based on the hierarchical search block-matching algorithm.

### FEATURE

- MPEG-4 Simple Profile @ Level 3 / H.263 Base Line
- AMBA AHB Interface
- Using Advanced MRMCS (Multi-Resolution search using Multiple Candidates and Spatial correlation of motion field) Algorithm
- Scalable image size: M x N macro-blocks up to 2048x2048
- Unrestricted Mode & Advanced Prediction Mode (4MV)
- INTRA / INTER Mode Decision
- Macroblock-based Padding
- Search Range: [-16, 15.5]
- Half-pel Search
- Double Buffering of frame Data
- Re-use of Overlapped Search Range Data
- Variable processing clock (HCLK ~ HCLK / 30)

## MPEG-4 MOTION ESTIMATION OPERATION

### BLOCK DIAGRAM

Figure 23-1 shows the functional block diagram of MPEG-4 Motion Estimation. This block includes two parts with different clocks, i.e., system clock part and motion estimation clock part.

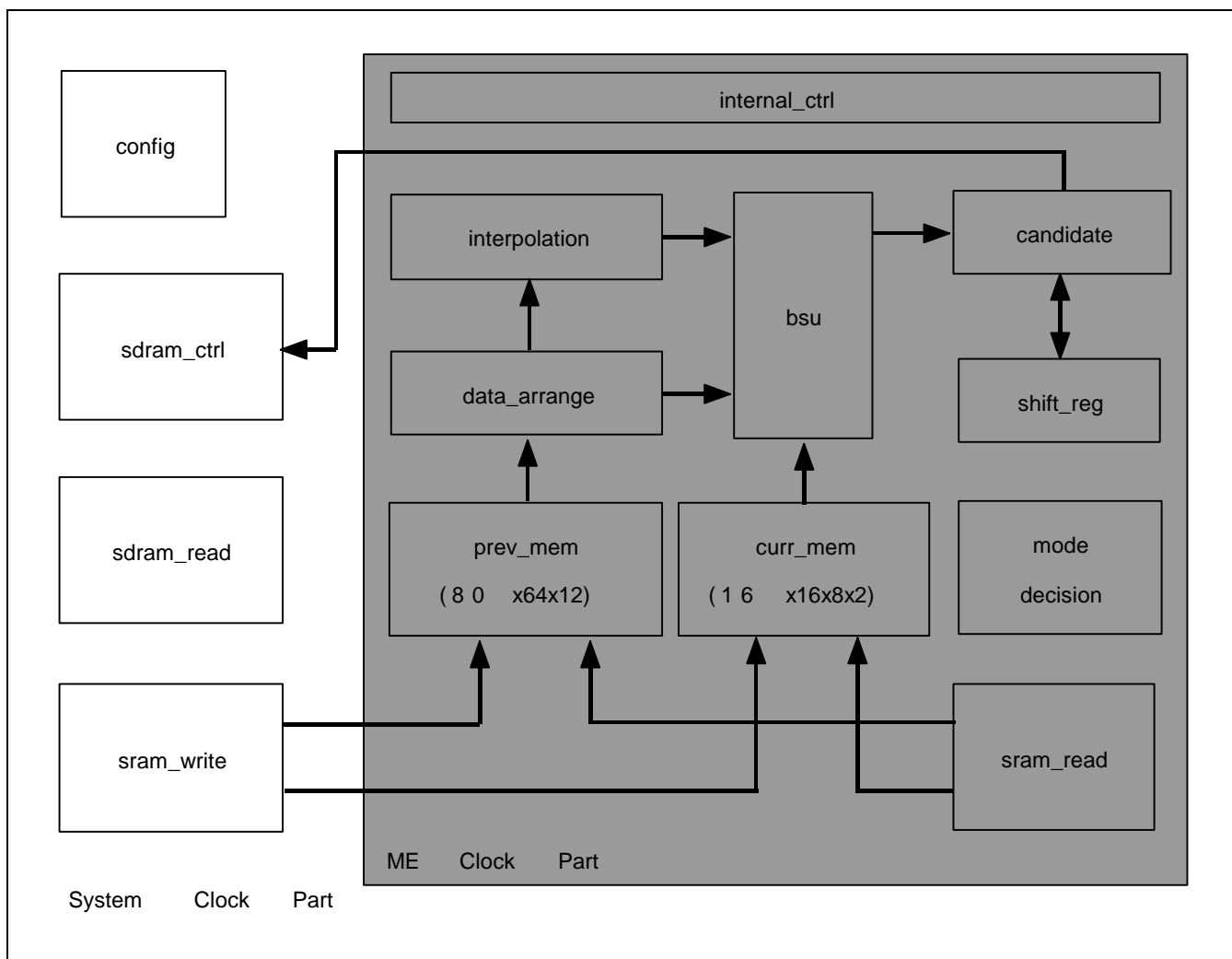
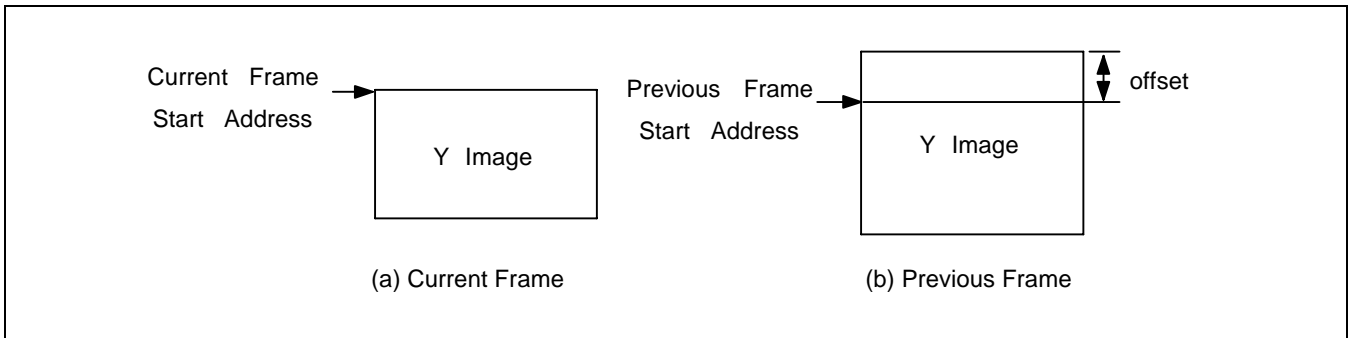

Figure 23-1. MPEG-4 Motion Estimation Block Diagram



**OPERATION FLOW**

- Firstly, set current, previous, and motion vector start address registers.
- Start address of previous frame must be considered the padding area.
- Set command register to operate motion estimation block.
- Current image data and padded previous image data of a macro-block are stored into the internal SRAM buffers from the external SDRAM.
- Operations to find motion vector of each macro-block are started after data transfer.
- After the completion of searches for each macro-block, the result data is written into the external SDRAM and then operations for one macro-block are finished.
- The operation unit in command register is set to decide the number of the macro-block to operate motion estimation continuously.



**Figure 23-2. Memory Map of Y (Luminance) Image for Current and Previous Frames**

**Table 23-1. Example of Sizes of Y Image and Offset for QCIF and CIF**

Image Format		QCIF	CIF
Y Image	Current Frame	176x144 = 25,344	352x288 = 101,376
	Previous Frame	$(176+16 \times 2) \times (144+16 \times 2) = 36,608$	$(352+16 \times 2) \times (288+16 \times 2) = 122,880$
	Offset	$(176+16 \times 2) \times 16 + 16 = 3,344$	$(352+16 \times 2) \times 16 + 16 = 6,160$

## RESULT DATA

- The result of the motion estimation for each macro-block is stored into the external SDRAM area assigned in motion vector start address register.
- The result data of each macro-block is as follows.

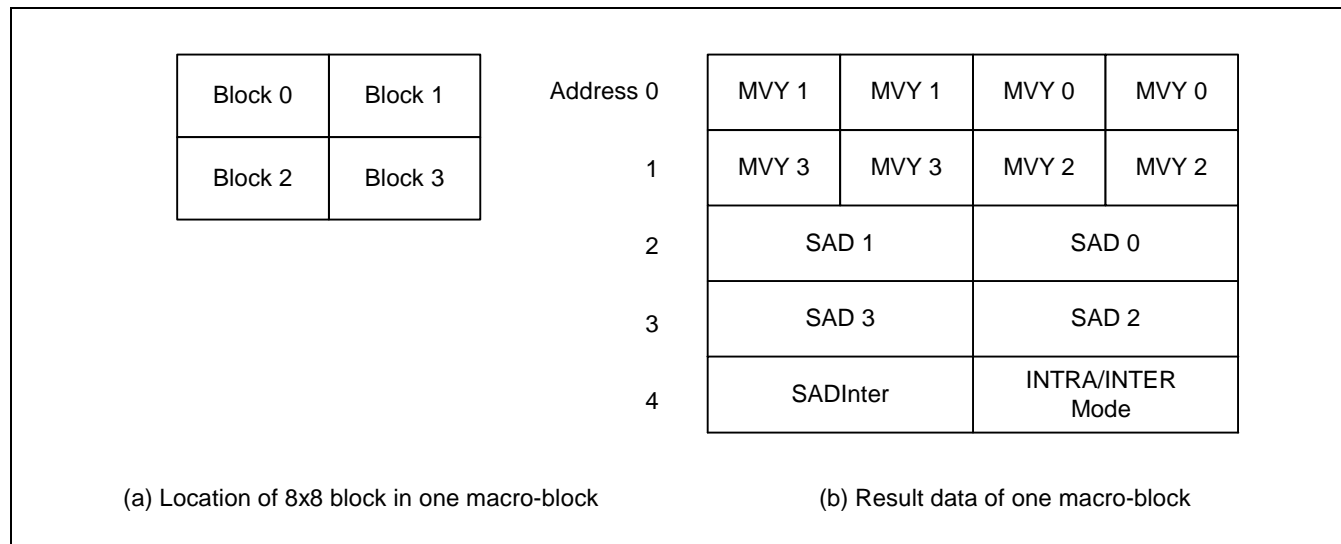

Figure 23-3. Motion Estimation Result Data

- MVX0, 1, 2, 3 and MVY0, 1, 2, 3 are X and Y components for motion vector of block 0, 1, 2, 3, respectively.
- The value of bit 0 of MVX0, 1, 2, 3 and MVY0, 1, 2, 3 indicates the value of half-pel unit. If this bit is 1, the value is 0.5. Otherwise, it indicates 0.0. Bit [7:1] is the signed number that is represented using 2's complement system. For example, if values of MVX0 and MVY0 are 0xE2 and 0x1B, respectively, the values of X and Y components of motion vector are -15.0 and 13.5, respectively.
- In the case of 4MV mode, motion vectors of 4 blocks are generated and in other cases, 4 motion vectors have the same value.
- SAD0, 1, 2 and 3 are the SAD values for each block and they can be used for DCT/Q skipping.
- The value of INTRA/INTER mode indicates that 0x0000 is INTER mode and 0xFFFF is INTRA mode. This value is only valid in case of MPEG-4 mode and always is 0x0000, that is, INTER mode in H.263 mode.
- SADinter is the result of  $\min\{SAD_{16}, SAD_8\}$  after half-pel operation and it is used for INTRA/INTER mode decision.

## MPEG-4 MOTION ESTIMATION SPECIAL REGISTERS

### CURRENT FRAME START ADDRESS REGISTER (ME\_CFSA)

Register	Address	R/W	Description	Reset Value
ME_CFSA	0x4880_0000	R/W	Current frame start address register	0x0000_0000

ME_CFSA	Bit	Description	Initial State
Current frame start address	[31:0]	Set current frame start address	0x0000_0000

**NOTE:** Current Frame Start Address is the start address of current Y image. Motion estimation operates only for Y (Luminance) image.

### PREVIOUS FRAME START ADDRESS REGISTER (ME\_PFSA)

Register	Address	R/W	Description	Reset Value
ME_PFSA	0x4880_0004	R/W	Previous frame start address register	0x0000_0000

ME_PFSA	Bit	Description	Initial State
Previous frame start address	[31:0]	Set previous frame start address	0x0000_0000

**NOTES:**

1. Previous Frame Start Address is the start address of previous Y image. Motion estimation operates only for Y (Luminance) image.
2. Previous Frame Start Address must be considered the padding area and it is the start address of the original previous image except the padding area.

### MOTION VECTOR START ADDRESS REGISTER (ME\_MVSA)

Register	Address	R/W	Description	Reset Value
ME_MVSA	0x4880_0008	R/W	Motion vector start address register	0x0000_0000

ME_MVSA	Bit	Description	Initial State
Motion vector start address	[31:0]	Set motion vector start address	0x0000_0000

**NOTES:**

1. Motion Vector Start Address is the start address to store the result data of motion estimation.
2. The number of the result data is determined according to the operation unit of command register.



**COMMAND REGISTER (ME\_CMND)**

Register	Address	R/W	Description	Reset Value
ME_CMND	0x4880_000C	R/W	Command register	0x0000_0001

ME_CMND	Bit	Description	Initial State
–	[31:18]	Reserved	0x0
Round control bit	[17]	0 = Round bit 0 1 = Round bit 1	0
4MV mode enable	[16]	0 = 16x16 prediction mode 1 = Advanced prediction mode (4MV)	0
–	[15:4]	Reserved	0x0
ME operation start bit	[3]	0 = Not active 1 = Enable	0
MPEG-4/H.263 mode select	[2]	0 = MPEG-4 mode 1 = H.263 mode	0
Frame start bit	[1]	0 = Not active 1 = Enable	0
Interrupt request clear bit	[0]	0 = Not active 1 = Clear	1

**NOTES:**

1. Frame start bit is enabled only when the first start of the frame.
2. ME operation start bit is enable every operation unit in the frame.
3. Interrupt request clear bit is cleared when ME operation start bit is enable at the same time.

**STATUS & S/W RESET REGISTER (ME\_STAT\_SWR)**

Register	Address	R/W	Description	Reset Value
ME_STAT_SWR	0x4880_0010	R/(W)	Status & S/W reset register	0x0000_0002

ME_STAT_SWR	Bit	Description	Initial State
Reserved	[31:20] R	Reserved	0x0
BSU state buf FSM	[19:16] R	BSU state buf FSM in candidate block	0x0
Data flow FSM	[15:12] R	Data flow FSM in internal_ctrl block	0x0
BSU FSM	[11:8] R	BSU FSM in internal_ctrl block	0x0
Reserved	[7] R	Reserved	0
Control FSM	[6:4] R	Control FSM in sdram_ctrl block	0x0
Reserved	[3:2] R	Reserved	0x0
S/W reset bit	[1] R/W	0 = set S/W reset 1 = clear S/W reset	1
Motion estimation status bit	[0] R	0 = idle 1 = busy	0

**NOTES:**

1. In case of not using interrupt, motion estimation operation must be started when motion estimation status bit is "0".
2. S/W reset bit is used to reset motion estimation block. It reset special registers and internal finite state machines.
3. Since S/W reset bit keeps the written value until written into "0" or hardware reset, be careful to use S/W reset bit.

**CONFIGURATION REGISTER (ME\_CNFG)**

Register	Address	R/W	Description	Reset Value
ME_CNFG	0x4880_0014	R/W	Configuration register	0x0010_0063

ME_CNFG	Bit	Description	Initial State
–	[31:25]	Reserved	0x0
Fast mode enable bit	[24]	0 = Disable 1 = Enable	0
–	[23]	Reserved	0
Threshold value	[22:16]	Threshold value to be compared to the intensity variation in the fast mode	0x10
–	[15:14]	Reserved	0x0
Operation unit	[13:0]	The number of macro-blocks to operate motion estimation continuously	0x0063

**NOTES:**

1. The operation unit is variable only inside one frame.
2. In fast mode, the execution time is considerably reduced with less PSNR.
3. Fast mode enable bit is only valid in case of MPEG-4 mode. In H.263 mode, this bit always is not enabled.

**IMAGE FORMAT REGISTER (ME\_IMGFMNT)**

Register	Address	R/W	Description	Reset Value
ME_IMGFMNT	0x4880_0018	R/W	Image format register	0x0000_080A

ME_IMGFMNT	Bit	Description	Initial State
–	[31:15]	Reserved	0x0
N value	[14:8]	The number of vertical macro-blocks minus one	0x08
–	[7]	Reserved	0
M value	[6:0]	The number of horizontal macro-blocks minus one	0x0A

# 24

## MPEG-4 MOTION COMPENSATION

### OVERVIEW

The MPEG-4 motion compensation block is a part of MPEG-4 Video CODEC. Motion compensation is a key element in the inter compression. In inter compression pixels in a region of a previous frame are used to predict pixels in a region of the current frame. Differences between the previous frame and the mced frame are then coded to whatever accuracy is affordable at the desired bit-rate.

### FEATURE

- MPEG-4 Simple Profile @ Level 3 / H.263 Base Line
- AMBA AHB Interface
- 8x8 Block-based Motion Compensation
- Scalable image size: M x N macro-blocks up to 2048x2048
- Dedicated DMA
- Unrestricted Mode & Advanced Prediction Mode (4MV)
- Search Range: [-32, 31.5]
- Half-pel Search
- Error Concealment Support
- Encoding / Decoding

## MPEG-4 MOTION COMPENSATION OPERATION

### BLOCK DIAGRAM

Figure 24-1 shows the functional block diagram of MPEG-4 Motion Compensation.

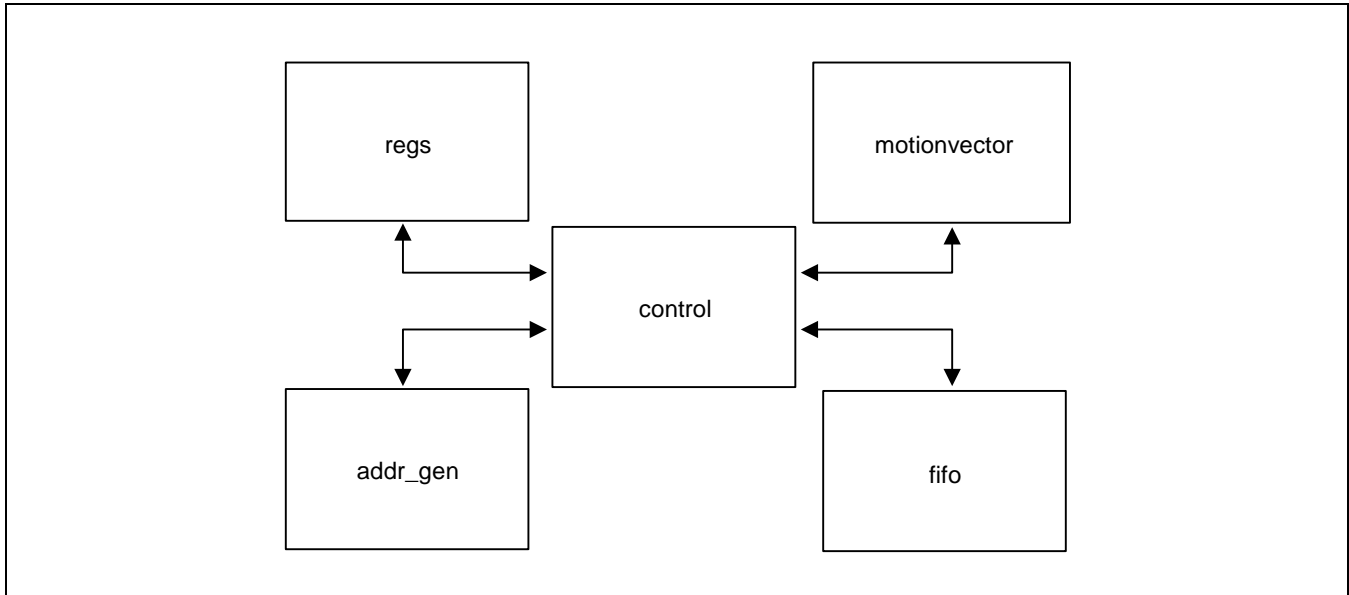
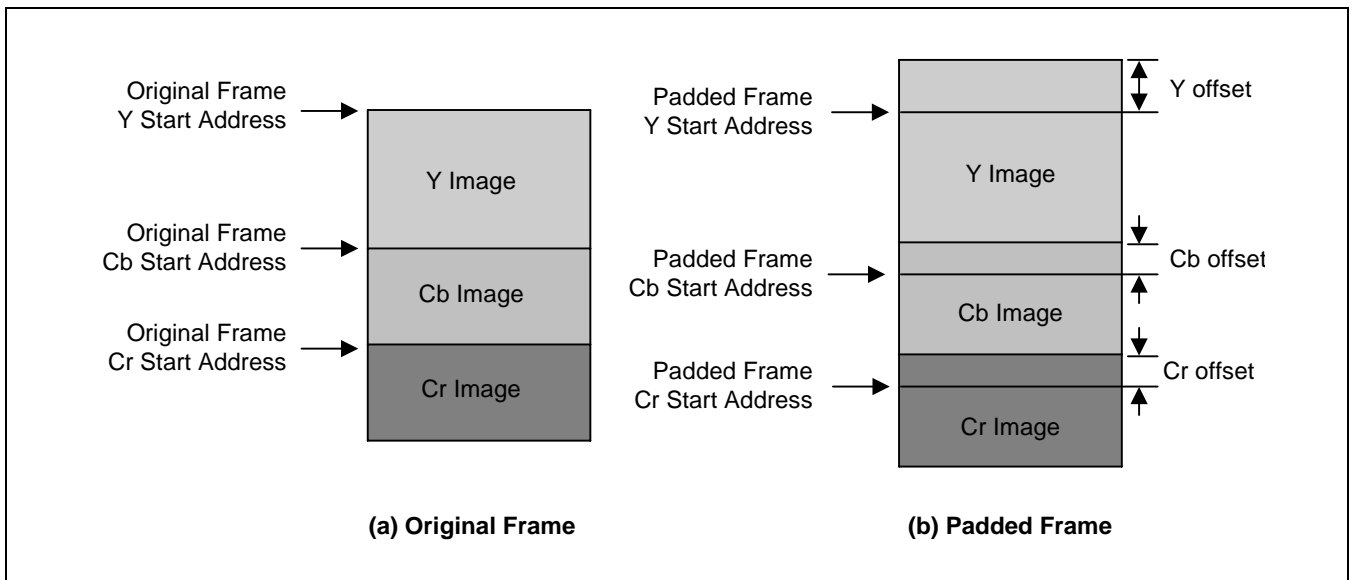

Figure 24-1. MPEG-4 Motion Compensation Block Diagram



**OPERATION FLOW**

- Firstly, set Y/Cb/Cr start address registers of current and previous. Each start address of current and previous frames must be considered the padding area.
- Secondly, set motion vector start address register.
- Set command register to operate motion compensation block.
- The operation unit in command register is set to decide the number of the macro-block to motion compensation continuously.
- The operation of motion compensation is as follows.  
Start → Motion Vector Read → Data Read → Data Processing → Data Write
- Motion compensation is operated in 8x8 block unit.
- Motion compensation cannot support the encoding and the decoding at the same time.
- Current and previous frame are padded frames.



**Figure 24-2. Y/Cb/Cr Image Memory Map of Original and Padded Frames**

**Table 24-1. Sizes of Y/Cb/Cr Image and Offset for QCIF and CIF**

		QCIF	CIF
Original Frame	Y	176x144 = 25,344	352x288 = 101,376
	Cb/Cr	88x72 = 6,336	176x144 = 25,344
Padded Frame	Y	$(176+16 \times 2) \times (144+16 \times 2) = 36,608$	$(352+16 \times 2) \times (288+16 \times 2) = 122,880$
	Cb/Cr	$(88+8 \times 2) \times (72+8 \times 2) = 9,152$	$(176+8 \times 2) \times (144+8 \times 2) = 30,720$
Offset	Y	$(176+16 \times 2) \times 16 + 16 = 3,344$	$(352+16 \times 2) \times 16 + 16 = 6,160$
	Cb/Cr	$(88+8 \times 2) \times 8 + 8 = 840$	$(176+8 \times 2) \times 8 + 8 = 1,544$

## CONFIGURATION OF QCIF / CIF FRAME

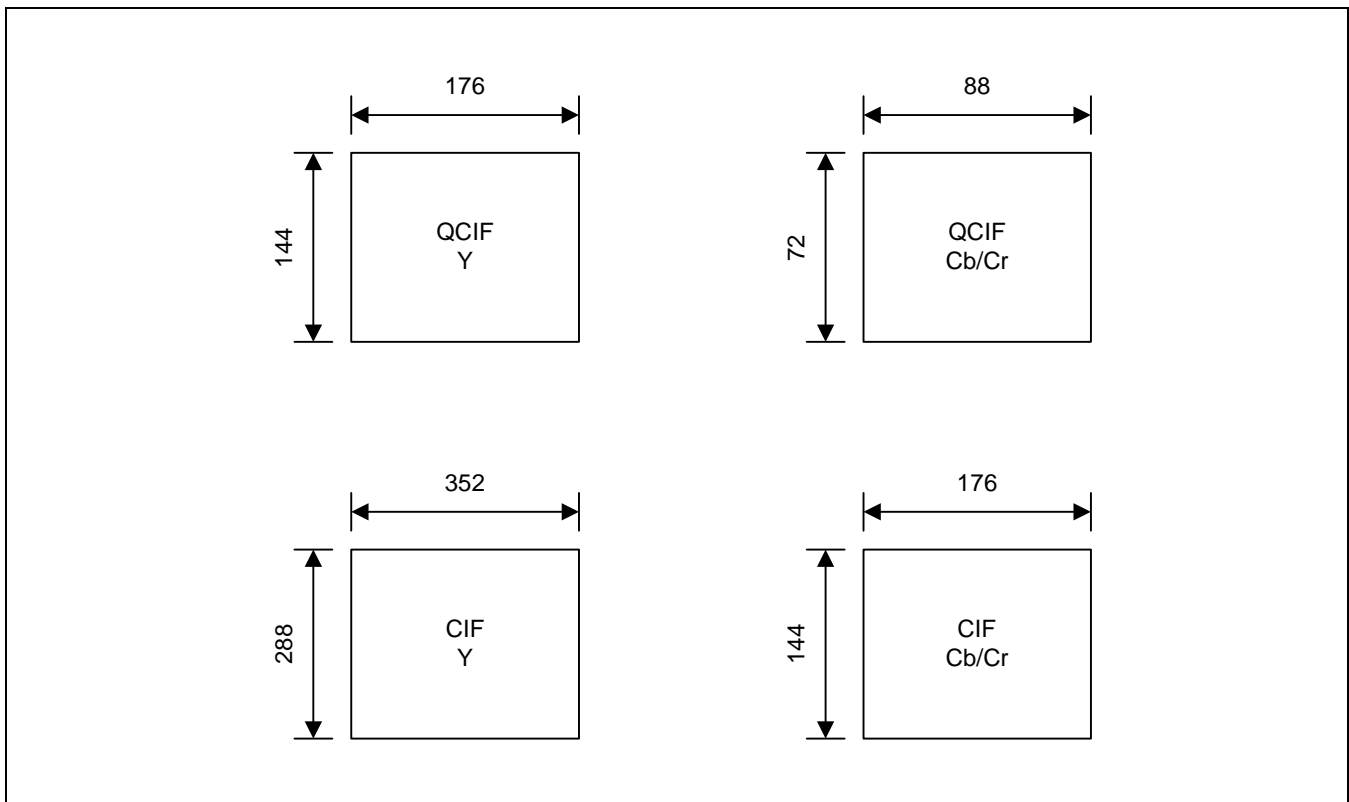

Figure 24-3. Y/Cb/Cr Configuration for QCIF/CIF Original Frame

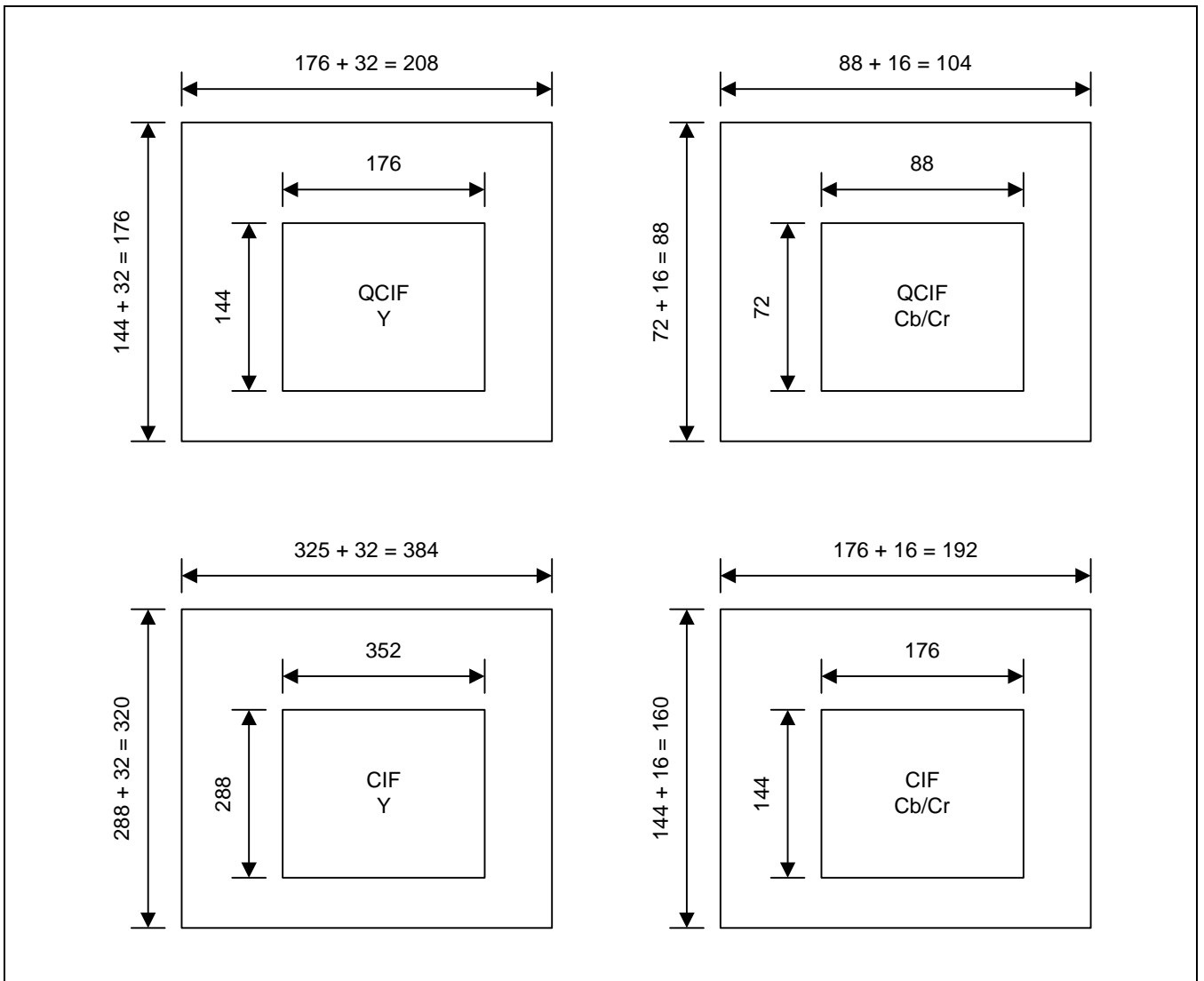

Figure 24-4. Y/Cb/Cr Configuration for QCIF/CIF Padded Frame

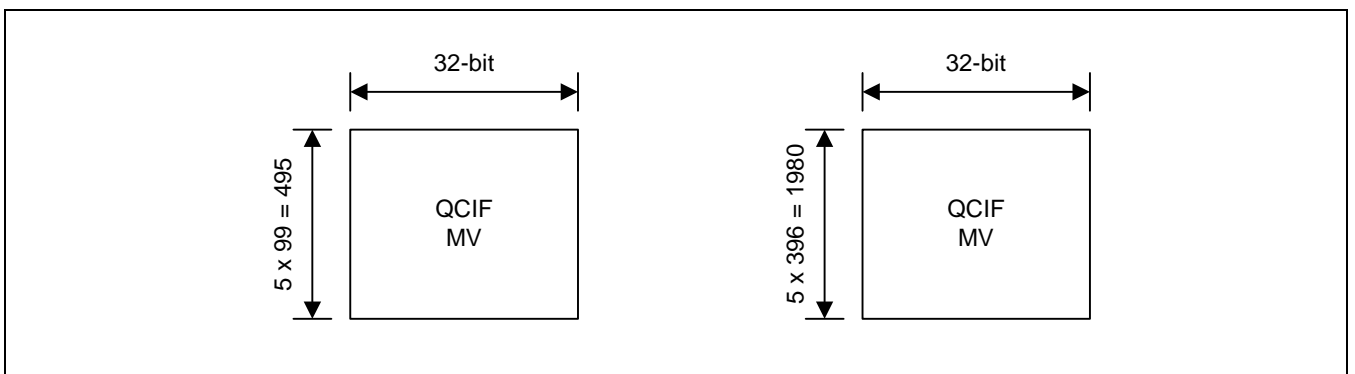

Figure 24-5. Motion Vector Configuration for QCIF/CIF Image

## MPEG-4 MOTION COMPENSATION SPECIAL REGISTERS

### PREVIOUS FRAME Y START ADDRESS REGISTER FOR THE ENCODER (MC\_PFYSA\_ENC)

Register	Address	R/W	Description	Reset Value
MC_PFYSA_ENC	0x48C0_0000	R/W	Previous frame Y start address register (ENC)	0x0000_0000

MC_PFYSA_ENC	Bit	Description	Initial State
Previous frame Y start address (ENC)	[31:0]	Set previous frame Y start address (ENC)	0x0000_0000

### MCED FRAME Y START ADDRESS REGISTER FOR THE ENCODER (MC\_MFYSA\_ENC)

Register	Address	R/W	Description	Reset Value
MC_MFYSA_ENC	0x48C0_0004	R/W	MCed frame Y start address register (ENC)	0x0000_0000

MC_MFYSA_ENC	Bit	Description	Initial State
MCed frame Y start address (ENC)	[31:0]	Set MCed frame Y start address (ENC)	0x0000_0000

### PREVIOUS FRAME Y START ADDRESS REGISTER FOR THE DECODER (MC\_PFYSA\_DEC)

Register	Address	R/W	Description	Reset Value
MC_PFYSA_DEC	0x48C0_0008	R/W	Previous frame Y start address register (DEC)	0x0000_0000

MC_PFYSA_DEC	Bit	Description	Initial State
Previous frame Y start address (DEC)	[31:0]	Set previous frame Y start address (DEC)	0x0000_0000

### MCED FRAME Y START ADDRESS REGISTER FOR THE DECODER (MC\_MFYSA\_DEC)

Register	Address	R/W	Description	Reset Value
MC_MFYSA_DEC	0x48C0_000C	R/W	MCed frame Y start address register (DEC)	0x0000_0000

MC_MFYSA_DEC	Bit	Description	Initial State
MCed frame Y start address (DEC)	[31:0]	Set MCed frame Y start address (DEC)	0x0000_0000

**PREVIOUS FRAME Cb START ADDRESS REGISTER FOR THE ENCODER (MC\_PFCbSA\_ENC)**

Register	Address	R/W	Description	Reset Value
MC_PFCbSA_ENC	0x48C0_0010	R/W	Previous frame Cb start address register (ENC)	0x0000_0000

MC_PFCbSA_ENC	Bit	Description	Initial State
Previous frame Cb start address (ENC)	[31:0]	Set previous frame Cb start address (ENC)	0x0000_0000

**PREVIOUS FRAME Cr START ADDRESS REGISTER FOR THE ENCODER (MC\_PFCrSA\_ENC)**

Register	Address	R/W	Description	Reset Value
MC_PFCrSA_ENC	0x48C0_0014	R/W	Previous frame Cr start address register (ENC)	0x0000_0000

MC_PFCrSA_ENC	Bit	Description	Initial State
Previous frame Cr start address (ENC)	[31:0]	Set previous frame Cr start address (ENC)	0x0000_0000

**MCED FRAME Cb START ADDRESS REGISTER FOR THE ENCODER (MC\_MFCbSA\_ENC)**

Register	Address	R/W	Description	Reset Value
MC_MFCbSA_ENC	0x48C0_0018	R/W	MCed frame Cb start address register (ENC)	0x0000_0000

MC_MFCbSA_ENC	Bit	Description	Initial State
MCed frame Cb start address (ENC)	[31:0]	Set MCed frame Cb start address (ENC)	0x0000_0000

**MCED FRAME Cr START ADDRESS REGISTER FOR THE ENCODER (MC\_MFCrSA\_ENC)**

Register	Address	R/W	Description	Reset Value
MC_MFCrSA_ENC	0x48C0_001C	R/W	MCed frame Cr start address register (ENC)	0x0000_0000

MC_MFCrSA_ENC	Bit	Description	Initial State
MCed frame Cr start address (ENC)	[31:0]	Set MCed frame Cr start address (ENC)	0x0000_0000

**PREVIOUS FRAME Cb START ADDRESS REGISTER FOR THE DECODER (MC\_PFCbSA\_DEC)**

Register	Address	R/W	Description	Reset Value
MC_PFCbSA_DEC	0x48C0_0020	R/W	Previous frame Cb start address register (DEC)	0x0000_0000

MC_PFCbSA_DEC	Bit	Description	Initial State
Previous frame Cb start address (DEC)	[31:0]	Set previous frame Cb start address (DEC)	0x0000_0000

**PREVIOUS FRAME Cr START ADDRESS REGISTER FOR THE DECODER (MC\_PFCrSA\_DEC)**

Register	Address	R/W	Description	Reset Value
MC_PFCrSA_DEC	0x48C0_0024	R/W	Previous frame Cr start address register (DEC)	0x0000_0000

MC_PFCrSA_DEC	Bit	Description	Initial State
Previous frame Cr start address (DEC)	[31:0]	Set previous frame Cr start address (DEC)	0x0000_0000

**MCED FRAME Cb START ADDRESS REGISTER FOR THE DECODER (MC\_MFCbSA\_DEC)**

Register	Address	R/W	Description	Reset Value
MC_MFCbSA_DEC	0x48C0_0028	R/W	MCed frame Cb start address register (DEC)	0x0000_0000

MC_MFCbSA_DEC	Bit	Description	Initial State
MCed frame Cb start address (DEC)	[31:0]	Set MCed frame Cb start address (DEC)	0x0000_0000

**MCED FRAME Cr START ADDRESS REGISTER FOR THE DECODER (MC\_MFCrSA\_DEC)**

Register	Address	R/W	Description	Reset Value
MC_MFCrSA_DEC	0x48C0_002C	R/W	MCed frame Cr start address register (DEC)	0x0000_0000

MC_MFCrSA_DEC	Bit	Description	Initial State
MCed frame Cr start address (DEC)	[31:0]	Set MCed frame Cr start address (DEC)	0x0000_0000

**MOTION VECTOR START ADDRESS REGISTER FOR THE ENCODER (MC\_MVSA\_ENC)**

Register	Address	R/W	Description	Reset Value
MC_MVSA_ENC	0x48C0_0030	R/W	Motion vector start address register (ENC)	0x0000_0000

MC_MVSA_ENC	Bit	Description	Initial State
Motion vector start address (ENC)	[31:0]	Set motion vector start address (ENC)	0x0000_0000

**MOTION VECTOR START ADDRESS REGISTER FOR THE DECODER (MC\_MVSA\_DEC)**

Register	Address	R/W	Description	Reset Value
MC_MVSA_DEC	0x48C0_0034	R/W	Motion vector start address register (DEC)	0x0000_0000

MC_MVSA_DEC	Bit	Description	Initial State
Motion vector start address (DEC)	[31:0]	Set motion vector start address (DEC)	0x0000_0000

**COMMAND REGISTER (MC\_CMND)**

Register	Address	R/W	Description	Reset Value
MC_CMND	0x48C0_0038	R/W	Command register	0x0000_0040

MC_CMND	Bit	Description	Initial State
–	[31:18]	Reserved	0x0
Rounding control bit	[17]	0 = Round bit 0 1 = Round bit 1	0
–	[16:7]	Reserved	0x0
Encoder / Decoder mode select	[6]	0 = Decoder 1 = Encoder	1
Interrupt request clear bit	[5]	0 = Not active 1 = Enable	0
MC operation start bit	[4]	0 = Not active 1 = Enable	0
–	[3:2]	Reserved	0x0
MC abort bit	[1]	0 = Not active 1 = Enable	0
–	[0]	Reserved	0

**NOTES:**

1. MC operation start bit is enabled every operation unit in the frame.
2. Interrupt request clear bit is cleared when MC operation start bit is enabled at the same time.
3. MC abort bit has the same function as S/W reset bit of Status & S/W Reset Register and is cleared automatically.



**STATUS & S/W RESET REGISTER (MC\_STAT\_SWR)**

Register	Address	R/W	Description	Reset Value
MC_STAT_SWR	0x48C0_003C	R/(W)	Status & S/W reset register	0x0000_0002

MC_STAT_SWR	Bit	Description	Initial State
–	[31:9] R	Reserved	0x0
Control FSM	[8:4] R	Control FSM in control block	0x0
–	[3:2] R	Reserved	0x0
S/W reset bit	[1] R/W	0 = Set S/W reset 1 = Clear S/W reset	1
Motion compensation status bit	[0] R	0 = Idle 1 = Busy	0

**NOTES:**

1. In case of not using interrupt, motion compensation operation must be started when motion compensation status bit is "0".
2. S/W reset bit is used to reset motion compensation block. It reset special registers and internal finite state machines.
3. Since S/W reset bit keeps the written value until written into "0" or hardware reset, be careful to use S/W reset bit.



**CONFIGURATION REGISTER (MC\_CNFG)**

Register	Address	R/W	Description	Reset Value
MC_CNFG	0x48C0_0040	R/W	Configuration register	0x0000_0063

MC_CNFG	Bit	Description	Initial State
MC X, Y count update enable bit	[31]	0 = Disable 1 = Enable	0
MC Y count update value	[30:24]	Update value when bit 31 is set to "1"	0x0
–	[23]	Reserved	0
MC X count update value	[22:16]	Update value when bit 31 is set to "1"	0x0
–	[15:14]	Reserved	0x0
Operation unit	[13:0]	The number of the macro-block to operate motion compensation continuously	0x0063

**NOTES:**

1. The operation unit is variable only inside one frame.
2. MC X, Y count update enable bit and MC X, Y count update value should be written at the same time to operate motion compensation for specific macro-blocks in the frame..

**IMAGE FORMAT REGISTER (MC\_IMGfmt)**

Register	Address	R/W	Description	Reset Value
MC_IMGfmt	0x48C0_0044	R/W	Image format register	0x0000_080A

ME_IMGfmt	Bit	Description	Initial State
–	[31:15]	Reserved	0x0
N value	[14:8]	The number of vertical macro-blocks minus one	0x08
–	[7]	Reserved	0
M value	[6:0]	The number of horizontal macro-blocks minus one	0x0A

# 25

## MPEG-4 DCTQ

### OVERVIEW

This specification defines the DCT, IDCT, Quantisation and Dequantisation engine for MPEG-4 codec (refer Figure 25-1). MPEG-4 DCTQ engine gets current macroblock, previous macroblock and quantisation information from main memory. After internal DCTQ operation, this engine writes quantized coefficients and reconstructed macroblock to main memory. Using quantisation factor, it is possible to control bit-rate for video streams. Padding operation for motion estimation supports on the writing reconstruction macroblock. Also, it is possible to setting intra or inter mode and Qp value with accessing quantisation information in memory. This engine has own DMA module. So, just by setting function attributes into DCTQ SFR (Special Function Register), this engine automatically performs DCT, IDCT, Quantisation, Dequantisation, and memory access.

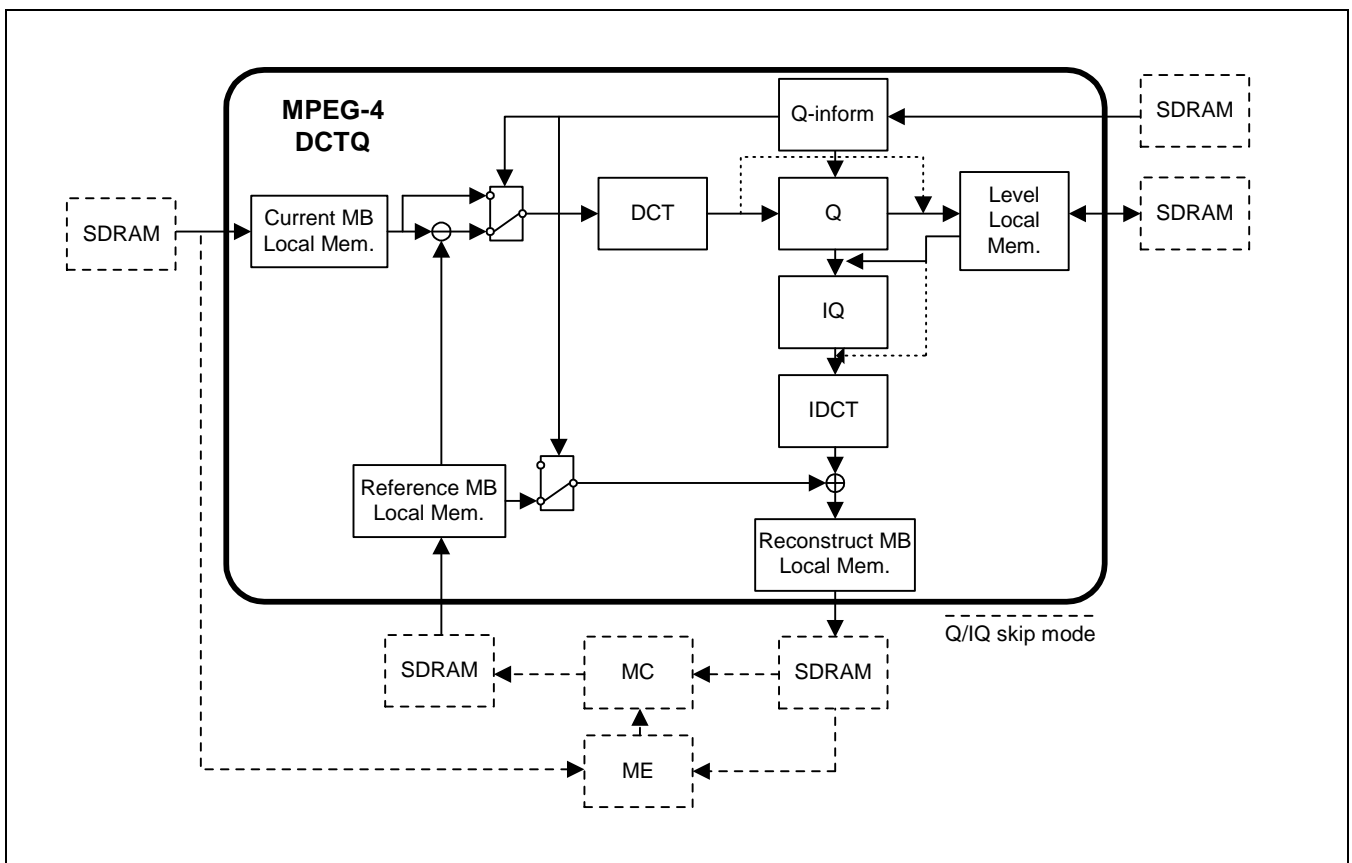

Figure 25-1. DCTQ Overview

## FEATURES

- H.263, MPEG-4 simple profile level 0, 1, 2 3 supports.
- DCT / IDCT / Q / IQ operations
- Residual extraction / Image reconstruction
- Padding operation for unrestricted motion compensation
- Rate control by Q-inform
- Intra refresh feasibility by Q-inform
- Dedicated DMA
- MPEG-4 encoder/decoder support
- JPEG DCT/IDCT support
- Variable aspect ratio and size (up to 4096 x 4096)

## TIMING DIAGRAM

DCTQ IP operates by OPUNIT. OPUNIT is a macroblock-based, which is 16x16 pixel array. One macroblock consists of six 8x8 block, which are 4 luminance blocks and, 2 chrominance blocks. DCTQ IP starts with DCTQ\_START signal by register setting. And, during operation, DCTQ\_BUSY signal remains High. After dctq operation, IRQ is generated. And then, DCTQ\_BUSY signal go to Low. CPU can read the state of DCTQ by referencing DCTQ\_BUSY. In this document, for convenience, dctq operation means dct, quantisation, dequantisation and, inverse dct operations.

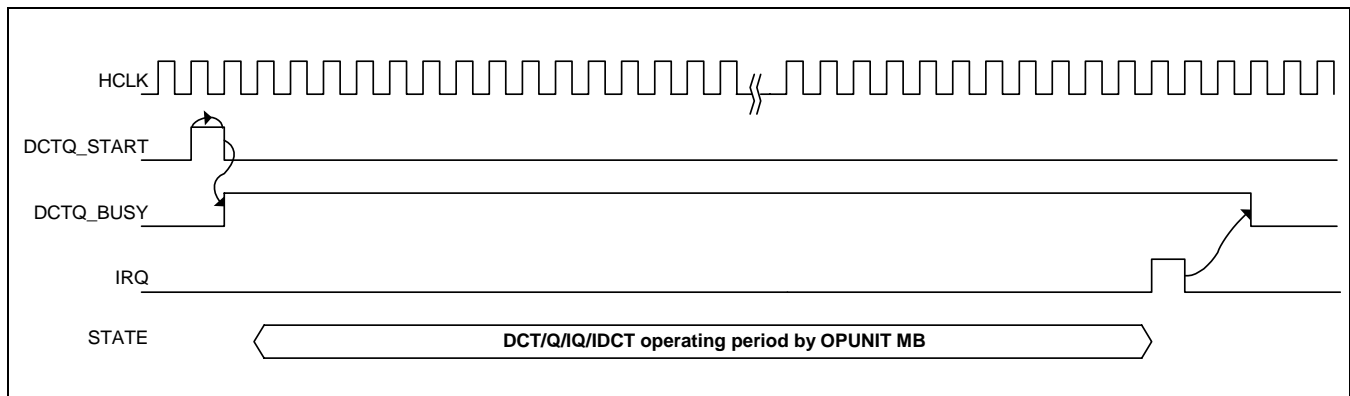

Figure 25-2. DCTQ Operation Timing Diagram

## SEPARATED CLOCK DOMAIN

DCTQ IP has two clock domains. The one is a system bus clock domain. And, the other is a DCTQ core clock domain. These two clock domains are independent. However, it is recommended to use integer number division for DCTQ core clock. For low power consumption, if possible, lower DCTQ core clock is requested within codec performance.

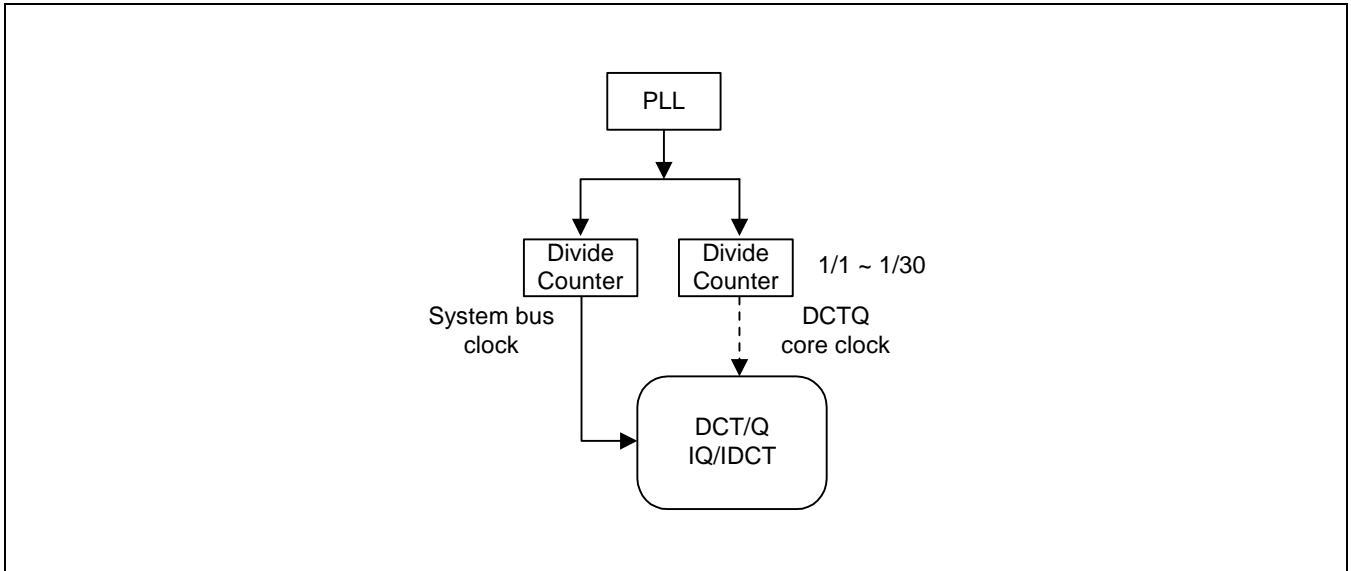

Figure 25-3. DCTQ clock domain

## DCT

A separable 2-dimensional Discrete Cosine Transform (DCT) is used.

$$F(u, v) = \frac{2}{N} C(u)C(v) \sum_{x=0}^{N-1} \sum_{y=0}^{N-1} f(x, y) \cos \frac{(2x+1)u\pi}{2N} \cos \frac{(2y+1)v\pi}{2N}$$

$$C(u), C(v) = \begin{cases} \frac{1}{\sqrt{2}} & \text{for } u, v = 0 \\ 1 & \text{otherwise} \end{cases}$$

In this IP, N value is fixed to 8. Before quantisation,  $F(u, v)$  is rounded. For reducing multiplication and reducing hardware size, row-column decomposition and Chen's algorithm is used.

## IDCT

Inverse DCT module follows next equation.

$$f(x, y) = \frac{2}{N} \sum_{u=0}^{N-1} \sum_{v=0}^{N-1} C(u)C(v)F(u, v) \cos \frac{(2x+1)u\pi}{2N} \cos \frac{(2y+1)v\pi}{2N}$$

## QUANTISATION

The Quantisation parameter  $Q_p$  takes integer values from 1 to 31. The quantisation stepsize is  $2xQ_p$ .

COF        A transform coefficient to be quantized.  
 LEVEL     Absolute value of the quantized version of the transform coefficient.  
 COF'      Reconstructed transform coefficient.

INTRA DC (In MPEG-4 mode)

$$\text{LEVEL} = \text{COF} // \text{dc\_scaler}$$

Others

$$\text{For INTRA: LEVEL} = |\text{COF}| / (2xQ_p)$$

$$\text{For INTER: LEVEL} = (|\text{COF}| - Q_p/2) / (2xQ_p)$$

Clipping to [-127:127] is performed for all coefficients except intra DC.

The sign of COF is then added to obtain COF' :  $\text{COF}' = \text{Sign}(\text{COF}) \times |\text{COF}|$

## DEQUANTISATION

INTRA DC (In MPEG-4 mode)

$$\text{COF}' = \text{LEVEL} \times \text{dc\_scaler}$$

Others

$$|\text{COF}'| = 0, \text{ if LEVEL} = 0$$

$$|\text{COF}'| = 2 \times Q_p \times \text{LEVEL} + Q_p, \text{ if LEVEL} \neq 0, Q_p \text{ is odd}$$

$$|\text{COF}'| = 2 \times Q_p \times \text{LEVEL} + Q_p - 1, \text{ if LEVEL} \neq 0, Q_p \text{ is even}$$

Clipping is [-2048:2047] is performed before IDCT.

## FRAME MEMORY MAP

The frame memories for DCTQ are shown in figure 1-4. The padding area of reference frame fixed to 16 pixel extensions from original image to outsides in any other image sizes. Because of DCTQed bits per pixel, the DCTQed frame memory size is double compared to original frame size. Show the bit format in figure 1-6. Q-information frame consists of the words of Q-information by macroblock units.

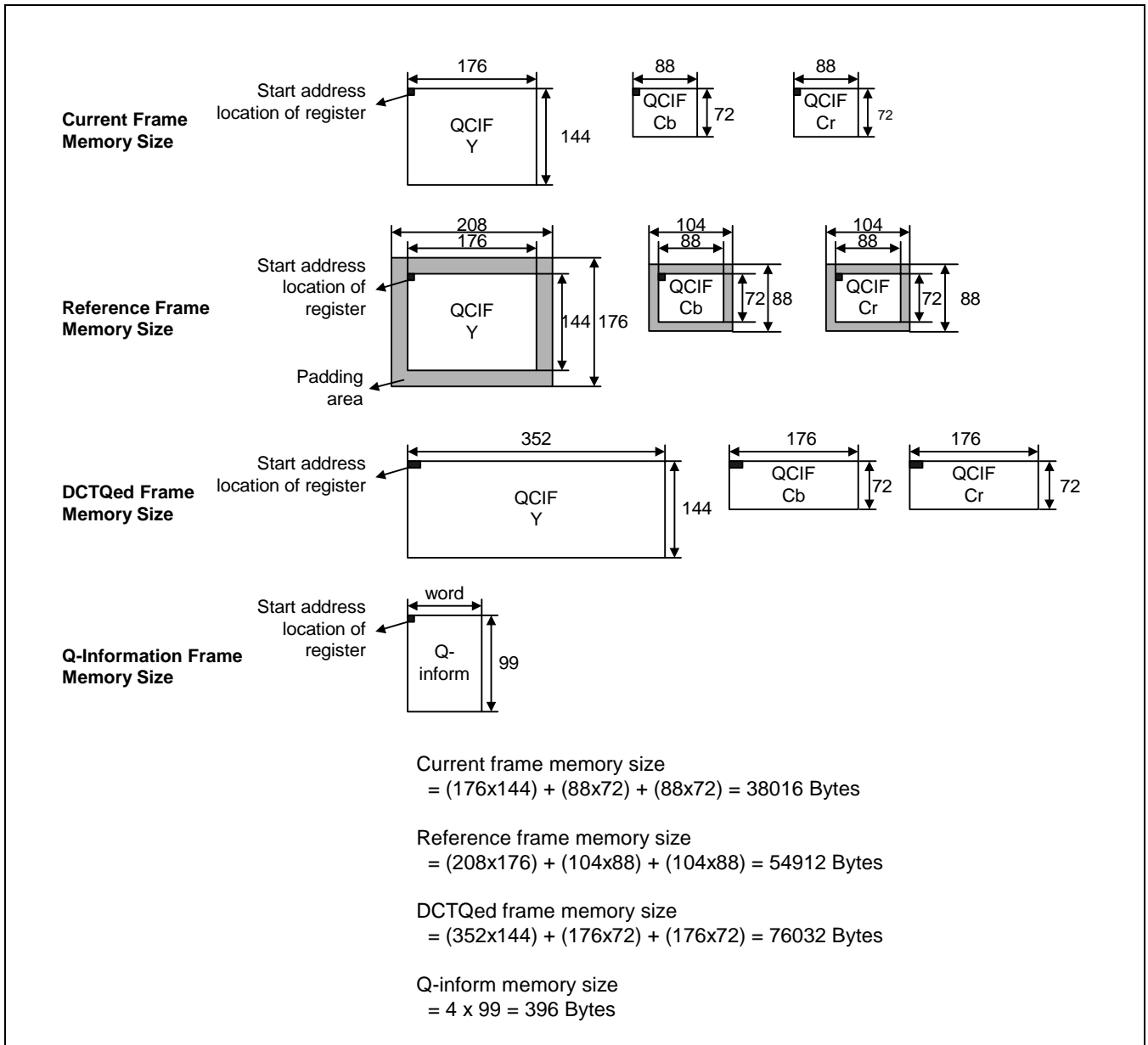

Figure 25-4. DCTQ Frame Memory Map in QCIF Case

## Q-INFORMATION

After DCTQ register setting, the first step of operations is the read of Q-information for macroblock. The DCTQ engine observes the Q-information and then determines the intra- or inter-modes, MB skip mode and, pick up Quantisation information. For CBP mode in the decoder, software has to write zero coefficients into the each skipped 8x8 blocks. In MB-skip case that is not\_coded(Inter, zero-MV), in the decoder, DCTQ operation can be skipped for next MB operation. This MB-skip mode is not recommended with VLC in the encoder.

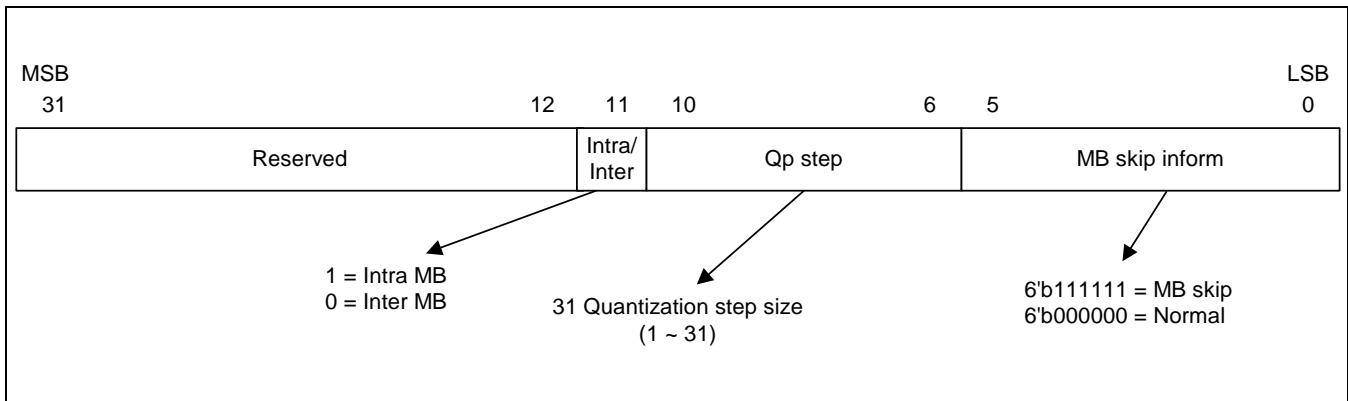

Figure 25-5. Q-Information Structure



## BIT FORMAT

The DMA operations are performed with word units. Internal memory accesses are mainly byte based. The dctq operations use the 9, 12 bits. Only little endian is supported in the words.

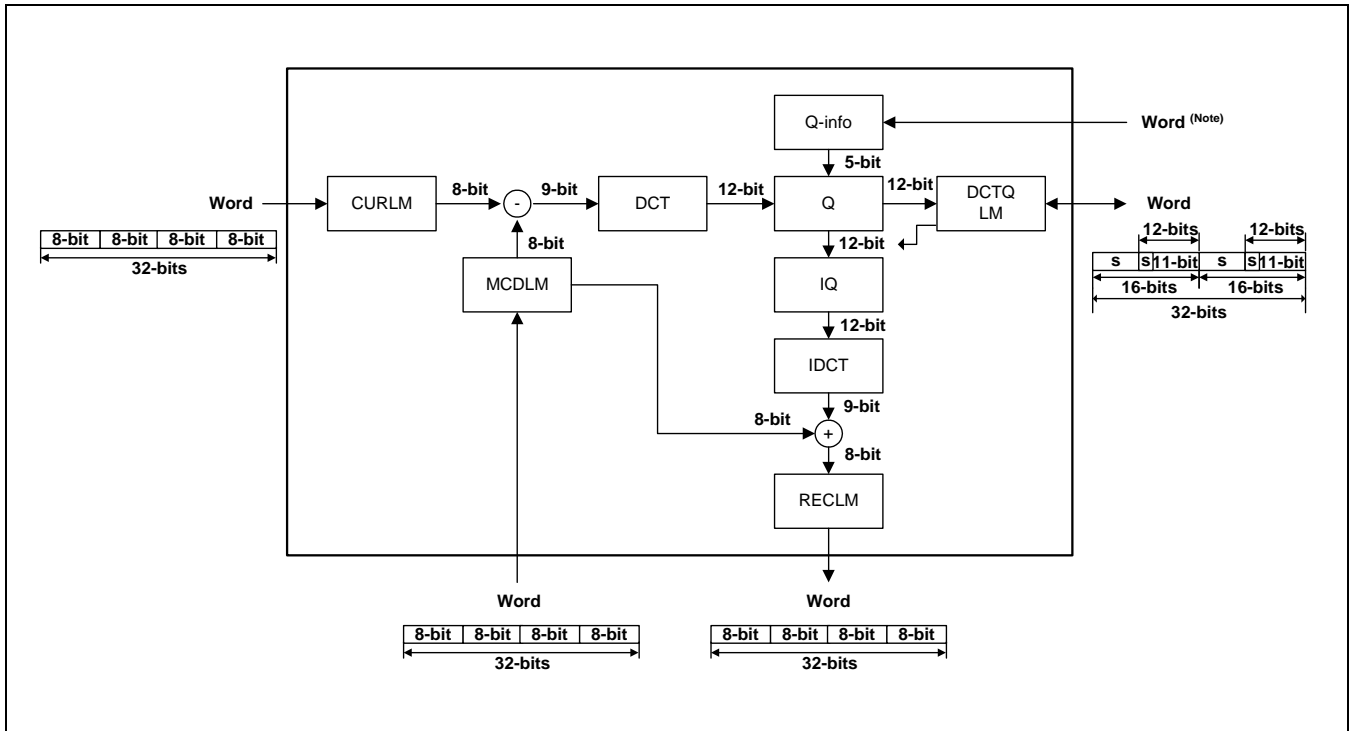

Figure 25-6. DCTQ Bit-Format

CURLM : Current MB local sram, MCDLM : MCed MB local sram, DCTQLM: DCTQed MB local sram, RECLM : Reconstructed MB local sram

**NOTE:** View the Q-inform structure in figure 1-5.

Output bit-format of coefficient is incompatible with 2's compliment for software. For getting sign, check the MSB of output coefficient. And, lower 12-bits are levels for VLC.

For block skip mode in decoder, software can put the '0' coefficients into coefficient memory. In inter-mode, this zero residuals add by MCed pixels for reconstruction image.

**TRANSPOSED COEFFICIENT OUTPUT**

The coefficient outputs of DCTQ are transposed in 8x8 block. One coefficient is stored into the half word. In memory, the sequences of coefficient are 0-8-16-24- etc. In macroblock level, the output sequence of 6 blocks are as shown in below diagram.

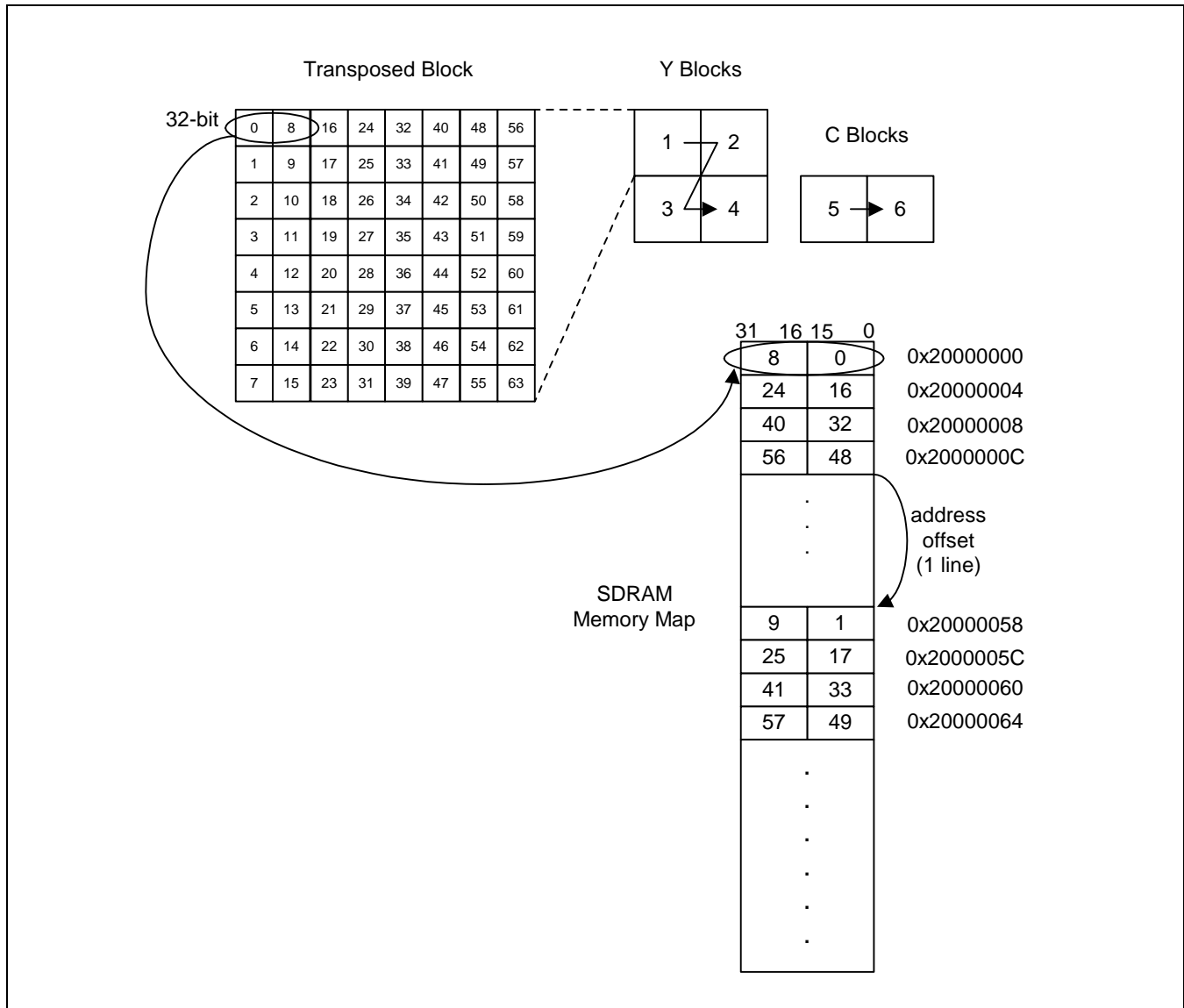

**Figure 25-7. Transposed Coefficient Output for MB**

**SOFTWARE INTERFACE**

This MPEG-4 DCTQ provides a generic data-exchange method. It is recommended that the CONTROL register should be set at the last SFR setting sequence.

## MPEG-4 DCTQ SPECIAL REGISTERS

### CURRENT FRAME Y START ADDRESS REGISTER

Register	Address	R/W	Description	Reset Value
SAYCF	0x4900_0000	RW	Current frame luminance start address	0x00000000

SAYCF	Bit	Description	Initial State
SAYCF	[31:0]	These bits indicate the luminance start address of current frame.	0x00000000

### CURRENT FRAME Cb START ADDRESS REGISTER

Register	Address	R/W	Description	Reset Value
SACBCF	0x4900_0004	RW	Current frame Cb start address	0x00000000

SACBCF	Bit	Description	Initial State
SACBCF	[31:0]	These bits indicate the chrominance Cb start address of current frame.	0x00000000

### CURRENT FRAME Cr START ADDRESS REGISTER

Register	Address	R/W	Description	Reset Value
SACRCF	0x4900_0008	RW	Current frame Cr start address	0x00000000

SACRCF	Bit	Description	Initial State
SACRCF	[31:0]	These bits indicate the chrominance Cr start address of current frame.	0x00000000

**REFERENCE FRAME Y START ADDRESS REGISTER**

Register	Address	R/W	Description	Reset Value
SAYRF	0x4900_000C	RW	Reference frame luminance start address	0x00000000

SAYRF	Bit	Description	Initial State
SAYRF	[31:0]	These bits indicate the luminance start address of reference frame.	0x00000000

**REFERENCE FRAME Cb START ADDRESS REGISTER**

Register	Address	R/W	Description	Reset Value
SACBRF	0x4900_0010	RW	Reference frame Cb start address	0x00000000

SACBRF	Bit	Description	Initial State
SACBRF	[31:0]	These bits indicate the chrominance Cb start address of reference frame.	0x00000000

**REFERENCE FRAME Cr START ADDRESS REGISTER**

Register	Address	R/W	Description	Reset Value
SACRRF	0x4900_0014	RW	Reference frame Cr start address	0x00000000

SACRRF	Bit	Description	Initial State
SACRRF	[31:0]	These bits indicate the chrominance Cr start address of reference frame.	0x00000000

**DCTQED FRAME Y START ADDRESS REGISTER**

Register	Address	R/W	Description	Reset Value
SAYDQF	0x4900_0018	RW	DCTQed frame luminance start address	0x00000000

SAYDQF	Bit	Description	Initial State
SAYDQF	[31:0]	These bits indicate the luminance start address for storing DCT and Quantized outputs.	0x00000000

**DCTQED FRAME Cb START ADDRESS REGISTER**

Register	Address	R/W	Description	Reset Value
SACBDQF	0x4900_001C	RW	DCTQed frame Cb start address	0x00000000

SACBDQF	Bit	Description	Initial State
SACBDQF	[31:0]	These bits indicate the chrominance Cb start address for storing DCT and Quantized outputs.	0x00000000

**DCTQED FRAME Cr START ADDRESS REGISTER**

Register	Address	R/W	Description	Reset Value
SACRDQF	0x4900_0020	RW	DCTQed frame Cr start address	0x00000000

SACRDQF	Bit	Description	Initial State
SACRDQF	[31:0]	These bits indicate the chrominance Cr start address for storing DCT and Quantized outputs.	0x00000000

**QUANTISATION FACTOR START ADDRESS REGISTER**

Register	Address	R/W	Description	Reset Value
SAQP	0x4900_0024	RW	Qp start address	0x00000000

SAQP	Bit	Description	Initial State
SAQP	[31:0]	These bits indicate the Qp start address for Quantisation informations.	0x00000000

**IMAGE SIZE REGISTER**

Register	Address	R/W	Description	Reset Value
IMGSIZE	0x4900_0028	RW	Image horizontal and vertical pixel number	0x00000000

Because DCTQ engine operates by macroblock unit, the horizontal and vertical pixel numbers should be the multiple of 16. For example, you can extract the exact SVGA image size after 800x608 dctq operation with dummy pixels.

IMGSIZE	Bit	Description	Initial State
Image_X	[28:16]	Image horizontal pixel number	0
Image_Y	[12:0]	Image vertical pixel number	0



**SHQ REGISTER**

Register	Address	R/W	Description	Reset Value
SHQ	0x4900_002C	RW	Short header quantization mode	0x00000000

SHQ	Bit	Description	Initial State
Is_SHQ	[27]	0 = MPEG-4 dc_scaler Q-mode for Intra-DC 1 = Short header Q-mode (/8, *8) for Intra-DC	0
Reserved	[26:0]	Must be zero	0

*Reserved SFR 0x49000030*

## CONTROL REGISTER

Register	Address	R/W	Description	Reset Value
DCTQCTRL	0x4900_0034	RW	Control register	0x00000000

DCTQCTRL	Bit	Description	Initial State
Reserved	[31:30]	Reserved	0
Coeff_not_write	[29]	Coefficients write operation to memory can be skipped with VLC IP 'On' state. In this case, DCTQ engine write the coefficient to the internal memory of VLC directly.	0
With_VLC	[28]	DCTQ operates by MB-unit with watching VLC operation (BUSY). In decoder mode, this bit must be zero. If only DCTQ is operating, this bit should be zero.	0
DCT_only	[27]	Quantization skip for JPEG mode	0
IDCT_only	[26]	De-quantization skip for JPEG mode	0
SWRST	[25]	This bit indicates the software reset of MPEG-4 DCTQ.	0
OPUNIT	[24:8]	These bits controls the number of DCTQ operations by macroblock unit. If these bits are 14'd99 in QCIF size, DCTQ operates during one frame without command.	0
DCTQBSY	[7]	This bit indicates the busy state of DCTQ. 1 = DCTQ is operating. 0 = DCTQ is not operating.	0
DCTQST	[6]	This bit indicates the start of DCTQ operation. This bit is auto-cleared.	0
Reserved	[5]	Reserved	0
ISH263	[4]	This bit indicates that the format of current DCTQ operation is H.263 or not. 1 = H.263 (without padding) 0 = MPEG-4 (with padding)	0
Reserved	[3]	Reserved	0
ISENC	[2]	This bit indicates that the current DCTQ operation is encoding or not. 1 = Encoding 0 = Decoding	0
Reserved	[1]	Reserved	0
FRST	[0]	This bit indicates the frame start signal, which is active only first OPUNIT. 1 = Frame start 0 = Normal	0

**Reserved SFR 0x49000038**

**Reserved SFR 0x4900003c**



## NOTES



# 26

## VLX

### OVERVIEW

VLX module consist of VLC (Variable Length Coding) and VLD (Variable Length Decoding) module.

VLC block does the entropy coding in MPEG4 system. It assigns small bits to a symbol that occurs frequently in the source data. On the other hand, it assigns large bits to a symbol that occurs rarely. As a result, the size of the coded data is smaller than that of the original. MPEG4 used a predefined table that assigns a code to each symbol (RUN, LEVEL, LAST) and cannot be redefined by the user in MPEG4 simple profile.

VLC received coefficient data and control signal from DCTQ h/w module. So SFR control bits must be set same value in DCTQ module SFR data in VLC mode.

VLD block does the entropy decoding in MPEG4 system. It reads the coded bit stream from the main memory, extracts one code from the coded bit stream, and generates the symbol from the extracted code. As the length of a code is variable, VLD block searches the coded bit stream step by step and compares the intermediate code value with the code table to get a complete code value.

VLD module is only 1 macro block operation so that always need to control interface between CPU. S/w must to be known the time of end of MB, so polling or interrupt signal generation in VLD h/w.

VLC and VLD operation are not supported operation simultaneous. If intra macros block in VLD mode need to DC prediction decoding and inverse scanning to use in DCTQ H/W module. And inter block in VLD mode don't need extra operation to use DCTQ module.

VLX module designed for AMBA2.0 and has two dedicated DMA, and 1 master and 1 slave AHB interface.

### FEATURE

- MPEG-4 Simple Profile
- AMBA AHB Interface
- Use Dedicated DMA
- Programmable Image size QCIF, CIF, VGA, QVGA etc.
- Include DC prediction in VLC mode..
- Interrupt and polling mode supported
- Support MPEG4 simple profile basic table excluding reversible VLC table



## MPEG-4 VLX (VARIABLE LENGTH CODING, DECODING) OPERATION

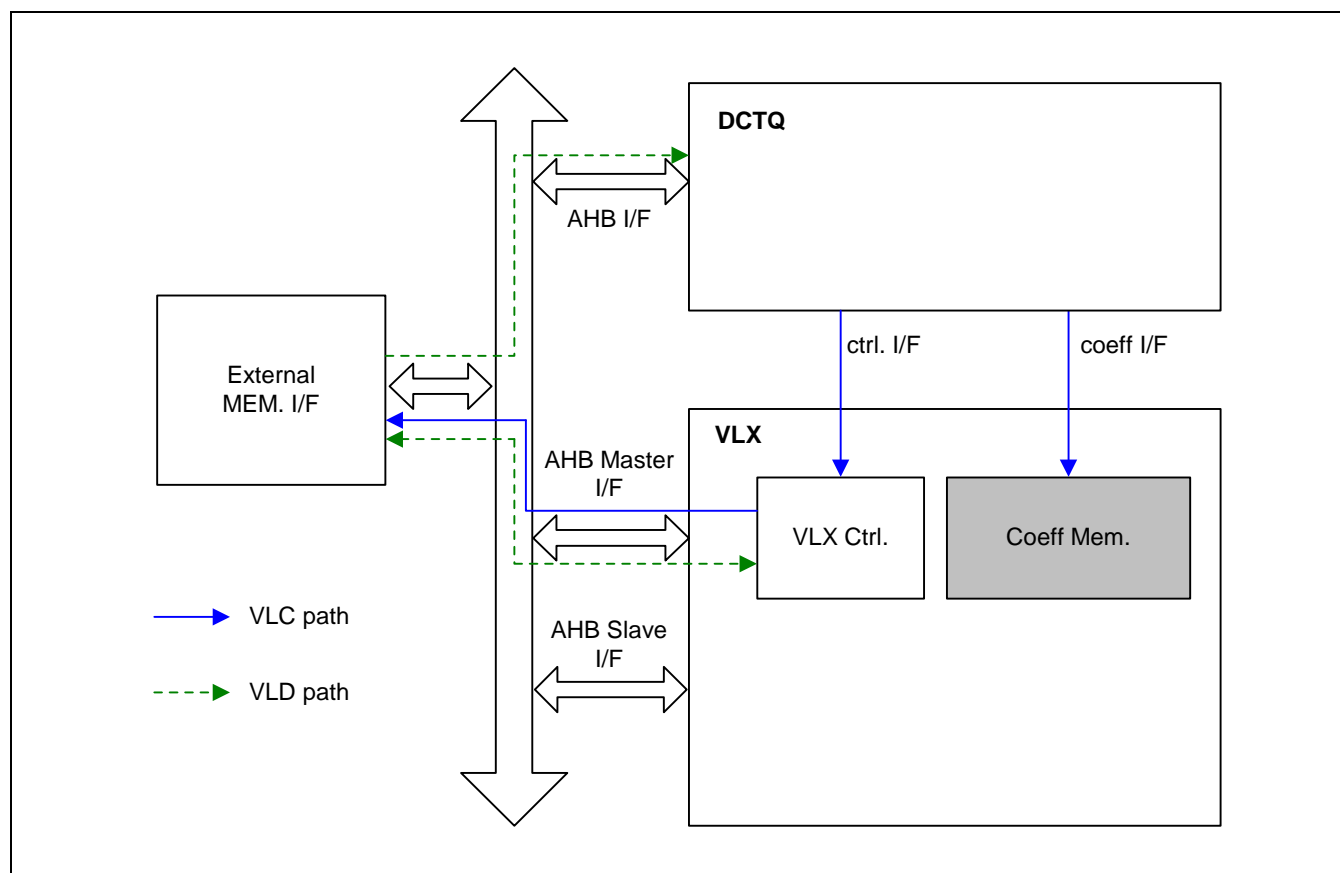

Figure 26-1. VLX Top Interface Block Diagram

### VLC

VLC block has 3 major blocks to code the input symbols. They are VLC coder, run-length coding (RLC), DC prediction block.

#### Run-Length Coder(RLC)

The output of the zigzag address generator is the sequence of the DCT coefficients that read in zigzag order or DCTQ zigzag order. These coefficients are coded to RLC. RLC coder result is LAST, RUN, LEVEL value.

In MPEG4 mode, the AC coefficients are coded to 3-D RLC code: (LAST, RUN, And LEVEL). RUN is the zero number before the non-zero value, LEVEL. The LAST indicates that the LEVEL is the last non-zero value in the DCT block.

RLC coder searched the 8x8 blocks of transform coefficients are scanned with "zigzag" scanning.

Zigzag order is explained Figure. 26-2

1	2	6	7	15	16	28	29
3	5	8	14	17	27	30	43
4	9	13	18	26	31	42	44
10	12	19	25	32	41	45	54
11	20	24	33	40	46	53	55
21	23	34	39	47	52	56	61
22	35	38	48	51	57	60	62
36	37	49	50	58	59	63	64

**Figure 26-2. ZigZag Scanning Method**

A three dimensional variable length coder is used to code transform coefficients. An EVENT is a combination of three parameters

- LAST    0: There are more nonzero coefficients in the block.  
          1: This is the last nonzero coefficient in the block.
- RUN     Number of zero coefficients preceding the current nonzero coefficient.
- LEVEL   Magnitude of the coefficient.

The most commonly occurring combinations of LAST, RUN, LEVEL are coded with variable length codes given standard table. The remaining combinations, no matched case in table use three ESCAPE mode coding. First, Level value change Level minus Lmax( Lmax is defined by RUN . Second, RUN value change RUN minus Rmax (Rmax is defined by Level). Last, FLC, fixed length coding, are coded with a 22 bit word fixed length coding consisting of ESCAPE (7-bit), LAST (1-bit), RUN (6-bit), LEVEL (8-bit), coding used.

## ENTROPY CODER

Entropy coding is performed after the run-length coding. MPEG4 in simple profile uses a predefined table that gives the code and the length of the code for each symbol. Entropy coder use many predefined table, DC table, intra luminance table, intra chrominance table, and various escape table. Etc.. . So, the table in MPEG4 can be fixed in hardware to speed up the entropy coding using direct matching method. it supports only the MPEG4 simple profile, the table is hardwired to speed up the VLC and to lower the power consumption.

### DC Prediction Coder

VLC support DC prediction operation. but AC prediction is not supported VLX module. So, scanning method is always zigzag scanning. DC prediction value calculates below fomular. Assume, 'X', 'A', 'B' and 'C' correspondingly refer to the current block, the previous block, the block above and to the left, and the block immediately above as shown.

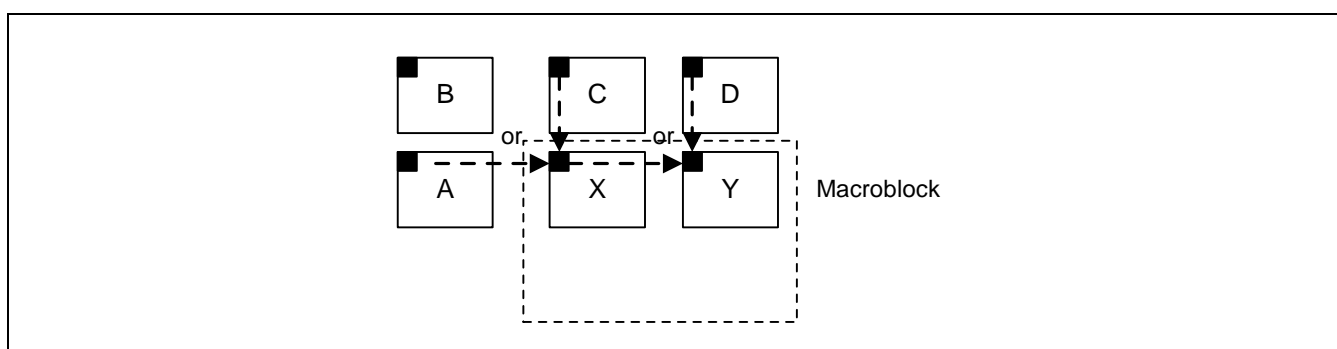

Figure 26-3. Previous Neighboring Blocks Used in DC Prediction

The differential DC is then obtained by subtracting the DC prediction,  $DCX'$  from DC of block 'X'.

if  $(|DCA - DCB| < |DCB - DCC|)$   $DCX' = DCC$

else  $DCX' = DCA$

$DCX = DCX - DCX'$

DC prediction h/w support Q-step Scaling method. Q-step scaling method is to compensate for differences in the quantisation of previous horizontally adjacent or vertically adjacent blocks used in AC prediction of the current block, scaling of prediction coefficients becomes necessary. Thus the prediction is modified so that the predictor is scaled by the ratio of the current quantisation stepsize and the quantisation stepsize of the predictor block.

### VLC Mode Operations Sequence

- Receiving the data and control signal from the DCTQ H/W module.
- 1 macro block data, zigzag ordered data receive form DCTQ module and data save COEF\_MEM in the VLX H/W module.
- SFR control bits already must be set.
- The value, after run-length coding, is coded with intra, Inter, escape run, escape level , dc code table, and then saved external memory.
- VLC output save external memory on 1 word value. Not coded information, from MSB to LSB data. {word count(16-bit), bit count(16-bit) }, VLC coeff. ordered save.VLX output in VLC mode are CBP information, Word count, Bit count VLCed stream data. Figure 26-4 show the output format in VLC mode.
- CBP information: Coded Block Pattern explain MB data exist or not . if Coded Block Patter value 1, that component has no DCTQ coefficient data.
- One MB has six block so CBP information is six bit output. 0 bit is y0 block and 5 bit is Cr block. Figure 26-4 show the CBP bit information.

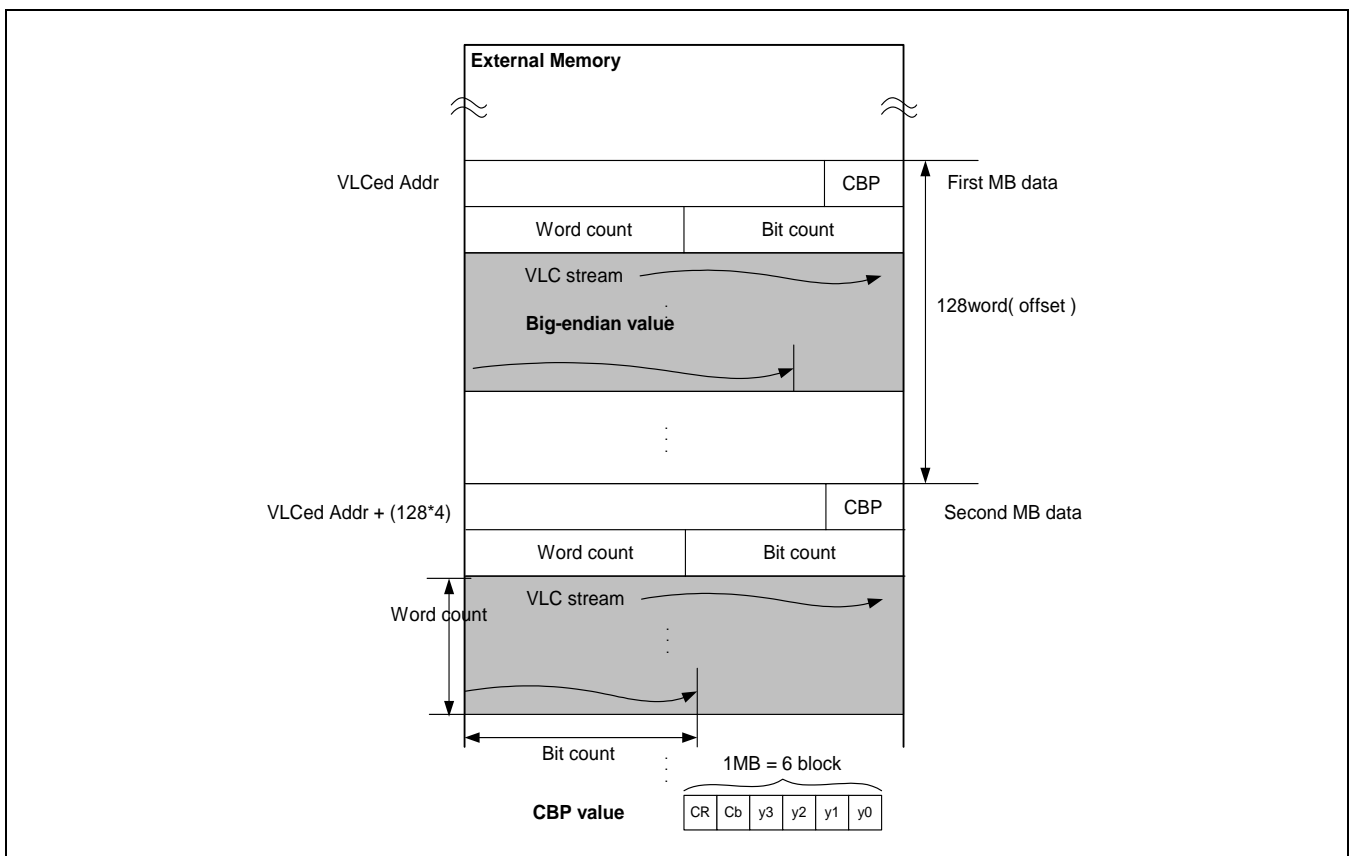

Figure 26-4. VLC output bit stream format

- Output of encoder, saved data in memory, is big-endian data
- Interrupt signal or busy signal generated by end of OP\_UNIT processing. Interrupt signal generation can be controlled by INT\_ENABLE bit.
- Busy signal put to DCTQ module and be set SFR bit.

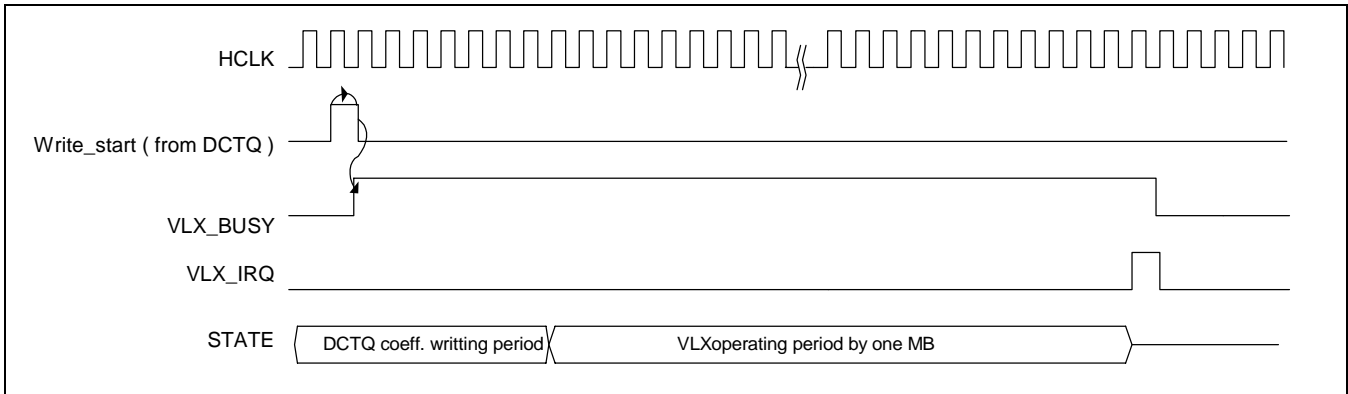

Figure 26-5. VLC Start, Busy, and Interrupt Signal Timing Diagram

At the VOP layer, `intra_dc_vlc_thr` allows switching between DC Intra VLC and AC Intra VLC when coding DC coefficients of Intra macroblocks. When the intra AC-VLC is turned on, INTRA-DC transform coefficients are not handled separately any more, but treated the same as all AC coefficients. This means a zero INTRA-DC will not be coded but will simply increase the run for the following AC-coefficients. But this H/W set `intra_dc_thr` value fixed zero value, so always threat DC coefficients.

**VLD**

VLD h/w support only coefficient bit stream variable length decoding, except header for decoding intra DC/AC inverse prediction. So VLD h/w needs to communicate to S/W per macro block.

This operation is shown Figure 26-6.

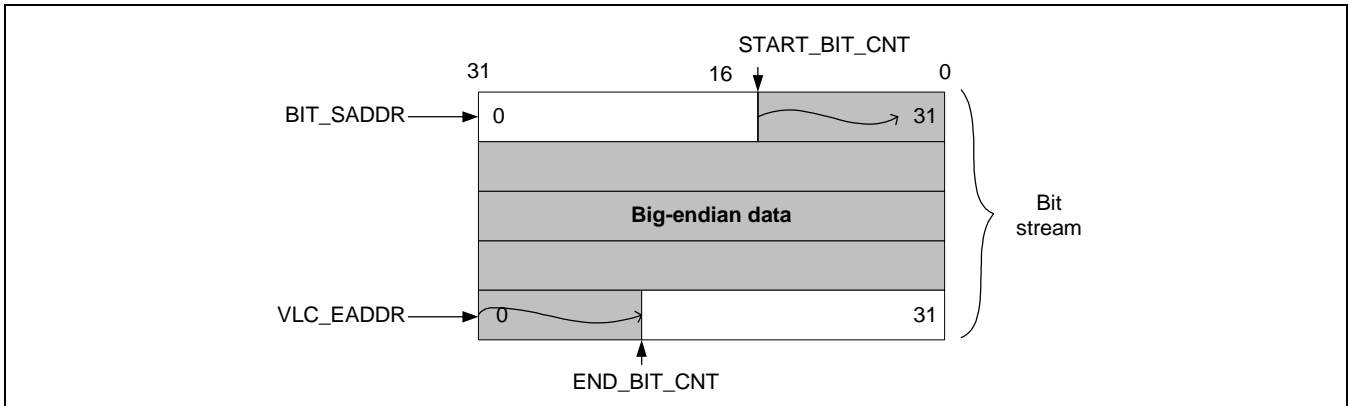

Figure 26-6. VLD Bit Stream H/W and S/W Interface Format.

S/W must be set BIT\_SADDR and START\_BIT\_CNT and bitstream data. BIT\_SADDR is address of start coefficient bit stream. And START\_BIT\_CNT is start bit of current macro block bit stream. And bitstream data must be big-endian data. VLD h/w generates VLC\_EADDR and END\_BIT\_CNT value after macro block VLD operation. Before next macro block start s/w have to find BIT\_SADDR and START\_BIT\_CNT after header parsing and VLD.

Decoded coefficient data saved external memory Y image, Cb image, and Cr image. Figure 26-7 is example external memory amount. So special function register Y\_START\_ADDR, CB\_START\_ADDR, CR\_START\_ADDR must be set.

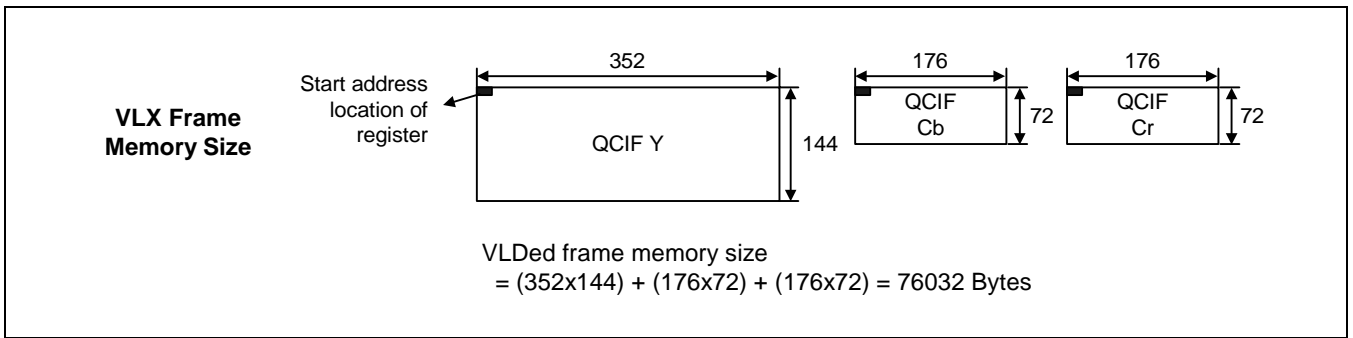

Figure 26-7. External Memory Amount in VLD Mode.

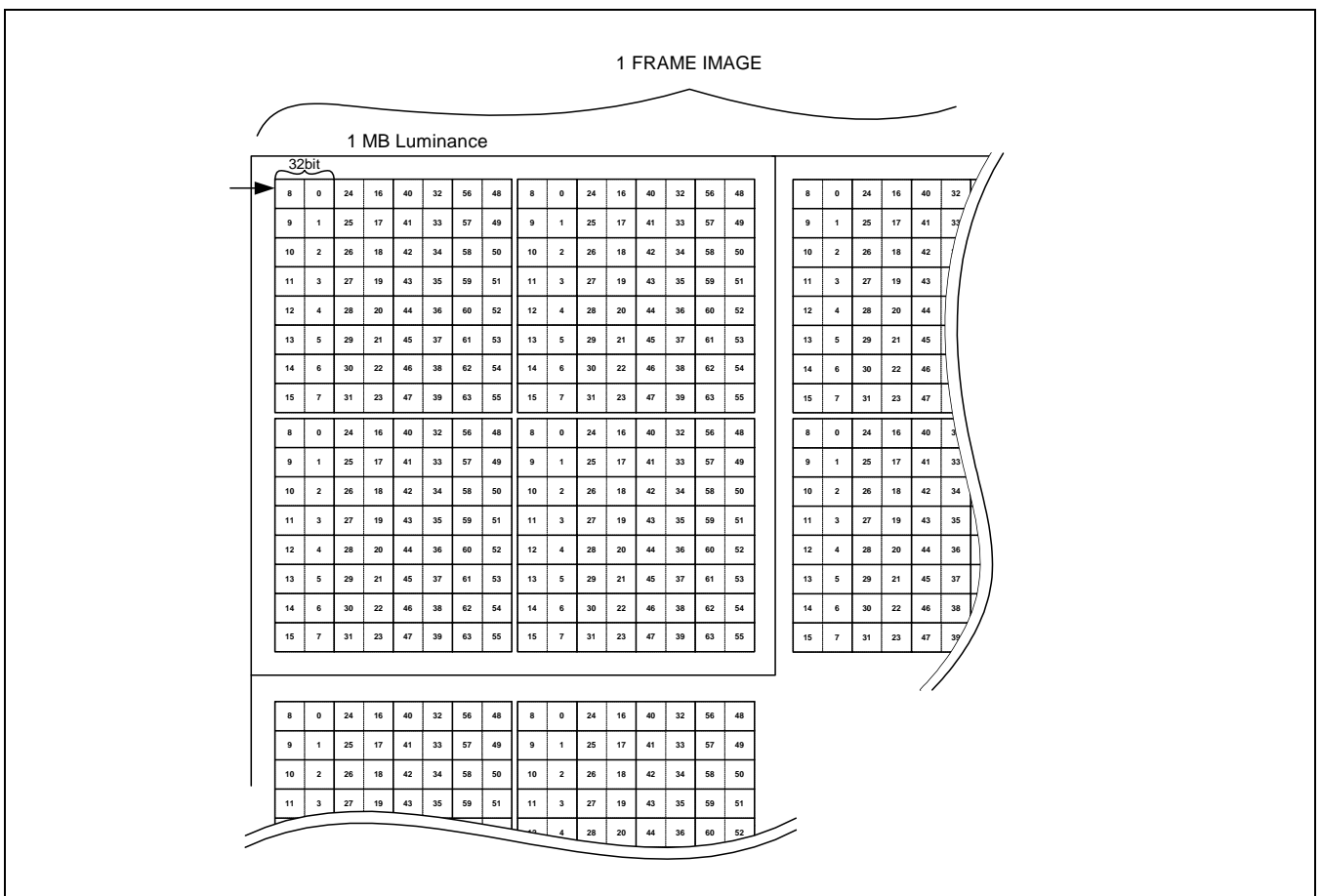

Figure 26-8. VLD Output Coefficient Format

VLD block has 3 major blocks. They are shifter, entropy decoding, run length decoding (RLD), Shifter include entropy coder. The operation and the sequence of the VLD operation are reverse to the VLC.

**Shifter**

The shifter gives the coded bit stream to the entropy-decoding block and does the shifting operation requested from the entropy-decoding block. The shifting operation is executed during the decoding process to give the left aligned coded bit stream to the entropy-decoding block.

**Entropy Decoder**

The entropy-decoding process has two steps. In first step, it extracts one code from the coded bit stream from the shifter and in second, it finds the symbol address corresponding to that code. In general case, during the process to extract one code the address for the symbol is calculated. The outputs of Entropy decoder are Run, Level and Last value. These values are input of RLD module.

**Run Length Decoder**

The output of the entropy decoding is (LAST, RUN, LEVEL) in MPEG mode. They are decoded to a sequence of the coefficients. This operation is done in the run-length decoding block. It is the reverse operation of the RLC block. And reads the sequence of coefficients from the run-length decoding block and writes the coefficients to the DCT/Q memory in zigzag address order or DCTQ zigzag address order. This is the reverse operation in VLC RLC.

**VLD Operation**

- VLD is operated by 1 MB OPUNIT.
- Decoding start address and bit count are accepted on each MB by S/W processing.

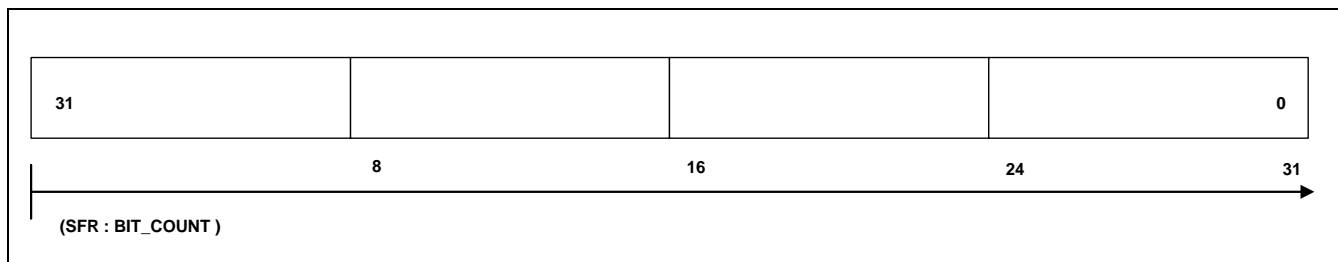

**Figure 26-9. MSB is First Bit Value in Output Bit Stream**

- VLD output is saved image format in external memory. Figure 26-7, 26-8 show the external memory
- DC prediction inverse coding and scanning are need in S/W processing in Intra mode.
- VLD processing explained Figure 26-10 VLD flow chart. VLD flow chart is partitioned S/W processing and H/W processing.



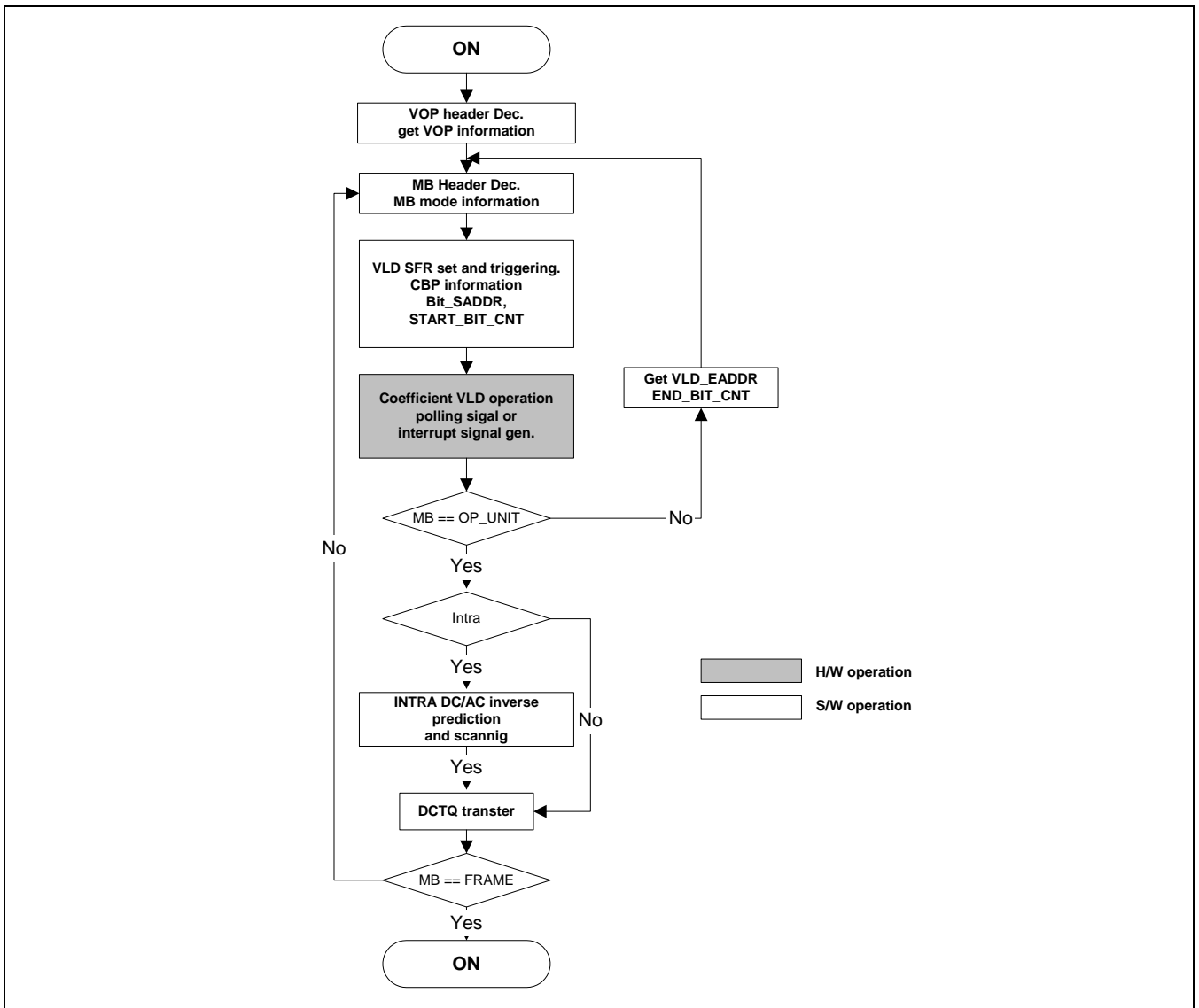

Figure 26-10. VLD Flow Chart and S/W and H/W Processing Partition

art signal, Busy signal and interrupt relation is shown Figure 26-11.

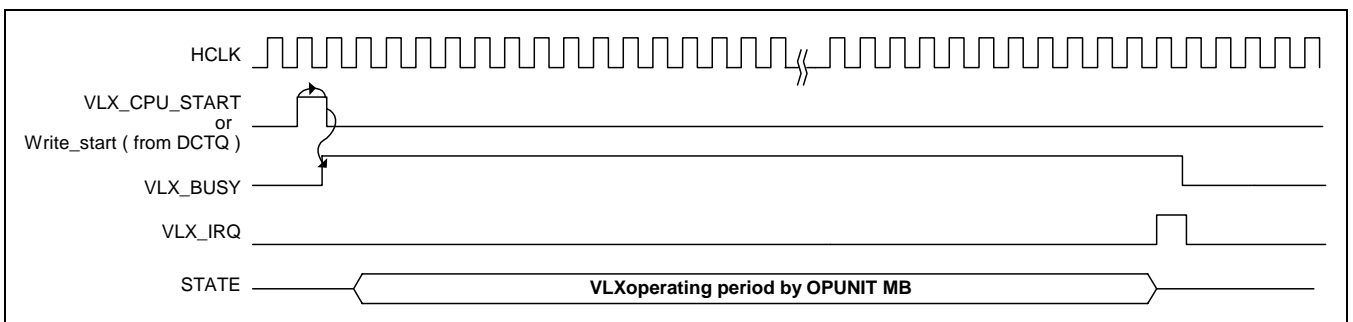

Figure 26-11. Start Signal, Busy Signal and Interrupt Signal in VLD Mode



## VLX (VLC AND VLD) SPECIAL REGISTERS

### VLX COMMON SFR

Register	Address	R/W	Description	Reset Value
COMMON1	0x4940_0000	R/W	VLX common control register 1	0x0000_0000

Common1	Bit	Description	Initial State
VLX_ON	[0]	VLX system on / off control bit, not start bit	0x0
–	[1]	Reserved	0x0
FRAME_START	[2]	1 = Frame START                      0 = Not frame start	0x0
VLX_START	[3]	1 = Encoder or Decoder start   0 = Disable	0x0
ENC_MODE	[4]	1 = Encoder                              0 = Decoder	0x0
INT_ENABLE	[5]	1 = Interrupt mode enable      0 = Disable	0x0
–	[8:6]	Reserved	0x0
OP_UNIT_SFR	[20:9]	Operation MB count	0x000
–	[21]	Reserved	0x0

#### NOTES:

1. VLX\_ON bit is on / off control.
2. FRAME\_START and CPU\_START must down before next COMMON1 set. Because of these signal is generated one pulse signal in VLX internal module ( only detect rising edge this signal ).
3. FRAME\_START signal must be set 1 time per 1 frame. And it must be set 0 before next OP\_UNIT processing start.
4. ENC\_MODE 1 : VLC operation , 0 : VLD operation.
5. INT\_ENABLE 0 : only polling mode ( busy signal is VLX\_BUSY value in VLX\_OUT1 special function register .)
6. OP\_UNIT SFR count value of macro block operation in VLC mode. Interrupt signal generation on end of OP\_UNIT. OP\_UNIT\_SFR must be set 1 value in VLD mode.
7. COMMON[1] and COMMON[8:6] must be set value '0'
8. COMMON[21] must be set value '1'.

## FRAME START ADDR

Register	Address	R/W	Description	Reset Value
FRAME_START_Y	0x4940_0004	R/W	Y coeff. frame start address	0x0000_0000

FRAME_START_Y	Bit	Description	Initial State
Y img frame start addr	[31:0]	Y coeff. frame start address in VLD mode	0x0000_0000

Register	Address	R/W	Description	Reset Value
FRAME_START_CB	0x4940_0008	R/W	CB coeff. frame start address	0x0000_0000

FRAME_START_CB	Bit	Description	Initial State
CB img frame start addr	[31:0]	CB coeff. frame start address in VLD mode	0x0000_0000

Register	Address	R/W	Description	Reset Value
FRAME_START_CR	0x4940_000c	R/W	CR coeff. frame start address	0x0000_0000

FRAME_START_CR	Bit	Description	Initial State
CR img frame start addr	[31:0]	CR coeff. frame start address in VLD mode	0x0000_0000

## VLX CONTROL REGISTER (VLX\_CON)

Register	Address	R/W	Description	Reset Value
VLC_CON1	0x4940_0010	R/W	Control register in VLC mode	0x0000_0000

VLC_CON1	Bit	Description	Initial State
IMG_XSIZE_SFR	[9:0]	Image x size set register	0x000
–	[10]	Reserved	0x0
SEL_SCAN_SFR	[12:11]	Scanning method select control bits.	0x0
–	[13]	Reserved	0x0
SW_RESET	[14]	S/w reset active high.	0x0

## NOTES:

1. IMG\_XSIZE\_SFR is pixel count value. Ex ) QCIF = 176, CIF = 352
2. 2'b00 : zigzag scan, 2'b11 : DCTQ zigzag format by dctq module format , others : ordered format.
3. S/W reset active high. And need to be down after high.
4. COMMON[10] must be set value '1'
5. COMMON[13] must be set value '0'

Register	Address	R/W	Description	Reset Value
VLC_CON2	0x4940_0014	R/W	Reserved	–

Register	Address	R/W	Description	Reset Value
VLC_CON3	0x4940_0018	R/W	VLC bit stream start address.	0x0000_0000

VLC_CON3	Bit	Description	Initial State
VLCED_ADDR	[31:0]	External address saved VLCed output stream.	0x0000_0000

**NOTE:** VLCED\_ADDR is bit stream base address output in VLC mode.

**VLCED\_ADDR[8:0] bit must be set 0 value!!.**

Register	Address	R/W	Description	Reset Value
VLC_CON4	0x4940_001c	R/W	Reserved	0x0000_0000

**VLD CONTROL REGISTER (VLD\_CON)**

Register	Address	R/W	Description	Reset Value
VLD_CON1	0x4940_0020	R/W	VLD control value setting register	0x0000_0000

VLD_CON1	Bit	Description	Initial State
–	[11:0]	Reserved	–
START_BIT_CNT	[17:12]	First bit count value when VLD start	0x00
IS_INTRA_VLD	[18]	1 = intra, 0 = inter mode in VLD	0x0
–	[19]	Reserved	–
CBP_VLD_SFR	[25:20]	CBP value	0x00
QP_SFR	[30:26]	QP value	0x00
–	[31]	Reserved	–

**NOTES:**

1. BIT\_STUFF\_SFR is bit count number of first start macro block bit streams.
2. Bit[11:0], Bit[19] must be set value '0'.
3. Bit[31] must be set '0x1'

Register	Address	R/W	Description	Reset Value
VLD_CON2	0x4940_0024	R/W	VLD BIT_SADDR	0x0000_0000

VLD_CON2	Bit	Description	Initial State
BIT_SADDR	[31:0]	VLD Bit stream start bit in VLD mode.	0x0000_0000

Register	Address	R/W	Description	Reset Value
VLD_CON3	0x4940_0028	R/W	Reserved	–

**VLX OUTPUT REGISTER 1 (VLX\_CON 1) – READ ONLY**

Register	Address	R/W	Description	Reset Value
VLX_OUT1	0x4940_002c	R	VLX output information register. 1	0x0000_0000

VLX_CON1	Bit	Description	Initial State
VLD_BUSY	[0]	VLX busy signal	0x0
N_ST_BIT_CNT	[6:1]	Next start bit count	0x00

**VLX OUTPUT REGISTER 2 (VLX\_CON 2) – READ ONLY**

Register	Address	R/W	Description	Reset Value
VLX_OUT2	0x4940_0030	R	VLX output information register. 2	0x0000_0000

VLX_CON2	Bit	Description	Initial State
N_START_ADDR	[31:0]	Next start address.	0x0000_0000

**NOTES:**

1. N\_START\_BIT\_CNT is next start bit counter number for next MB decoding.
2. N\_START\_ADDR is next start address for next MB decoding.

# 27 POST PROCESSOR

## OVERVIEW

Post processor performs video/graphic scale, video format conversion and color space conversion. It is composed of Data-Path, DMA controller and Register files as shown in the overall block diagram of Figure 27-1. Overall features are summarized as follows.

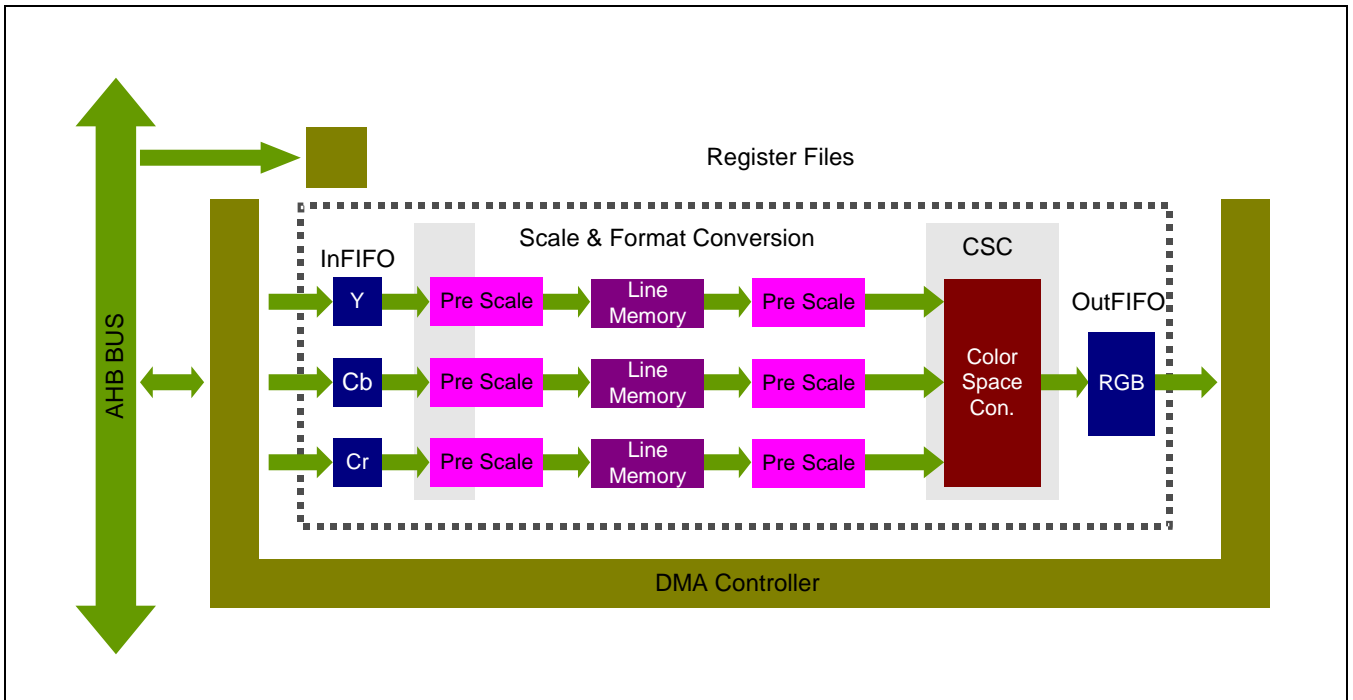

Figure 27-1. Block Diagram of Post Processor

**OVERALL FEATURES**

- AMBA AHB v2.0 compatible interface
- Dedicated DMA with offset address
- 3 Channel scaling pipelines for video/graphic scaling up/down or zooming in/out
- Video input format: 420, 422 format
- Graphic input format: 16-bit (565format) or 24-bit
- Output format: 16-bit (565 format) / 24-bit graphic data
- Programmable source and destination image size up to 2048 × 2048 resolution
- Programmable scaling ratio
- Format conversion for video signals
- Color space conversion
- Separate processing clock with AHB interface clock



## A SOURCE AND DESTINATION IMAGE DATA FORMAT

Various source and destination image formats can be selected according to the mode configuration as described in Table 27-1. Source image format is one of YCbCr420, YCbCr422, RGB16-bit (565format) and RGB 24-bit format. Destination image format is either RGB 16-bit (565format) or RGB 24-bit.

In the case of YCbCr420 source image format, each component of Y, Cb and Cr is stored in each own separated address space without any interleaving as shown in Case A of Figure 27-2 (a) and Figure 27-3. In the other cases, either byte or half-word interleaving is applied within unified address space as shown in Figure 27-2 (b). Byte interleaving order of YCbCr422 source image is selectable either YCbYCr or CbYCrY as shown in case B and C of Figure 27-2 (b) and Figure 27-3. Byte order of RGB 24-bit and half-word order of RGB 16-bit are shown in case D and E of Figure 27-2 (b) and Figure 27-3.

In both cases of YCbCr420 and YCbCr422 source image format, whether MPEG4 format or MPEG2/H.263 format needs to be selected according to the sampling position of the chroma information as shown in Figure 27-4.

All source and destination image data need to be stored in memory system aligned with word boundary. It means that neither byte nor half-word size DMA operations are supported (see chapter 27-4 for DMA operation). Therefore, the width of source and destination image should be selected to satisfy the word boundary condition (see chapter 27-3 for image size).

**Table 27-1. Mode Configuration for Video/Graphic Source Format and the Corresponding Data Format**

Mode[8] SRC420	Mode[3] InRGB	Mode[2] Inter- Leave	Mode[1] InRGB Format	Mode[0] InYCbCr Format	Description	
					Video/Graphic Format	Data Format In Figure27-2 and 3
1	0	0	1	×	420 YCbCr Format	A
0	0	1	1	0	422 YCbYCr Format	B
0	0	1	1	1	422 CbYCrY Format	C
0	1	1	1	×	RGB 24-bit true color	D
0	1	1	0	×	RGB 16-bit Format	E

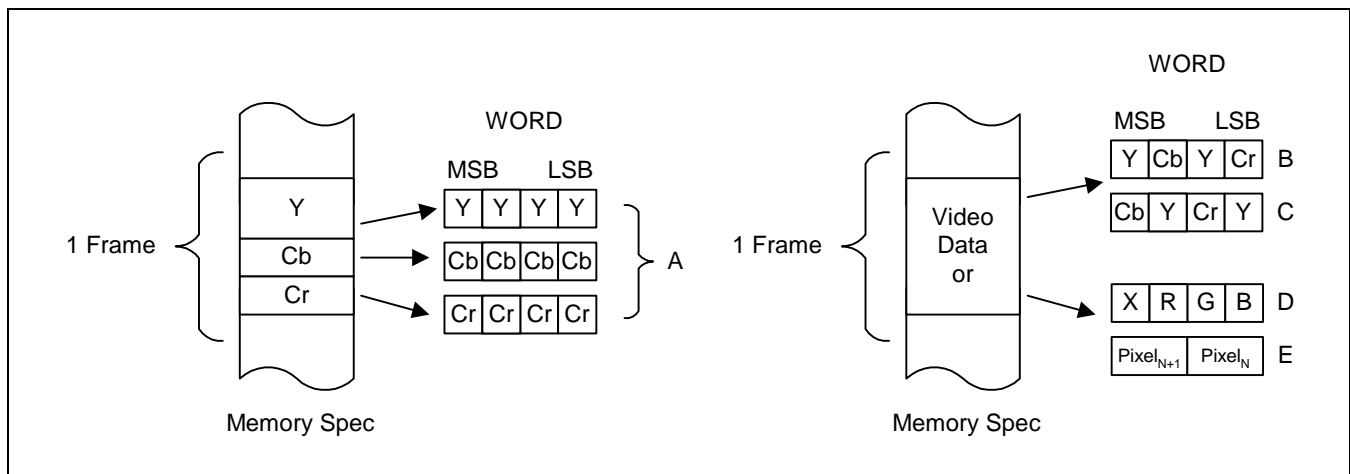

Figure 27-2. Data Format Stored in External Memory

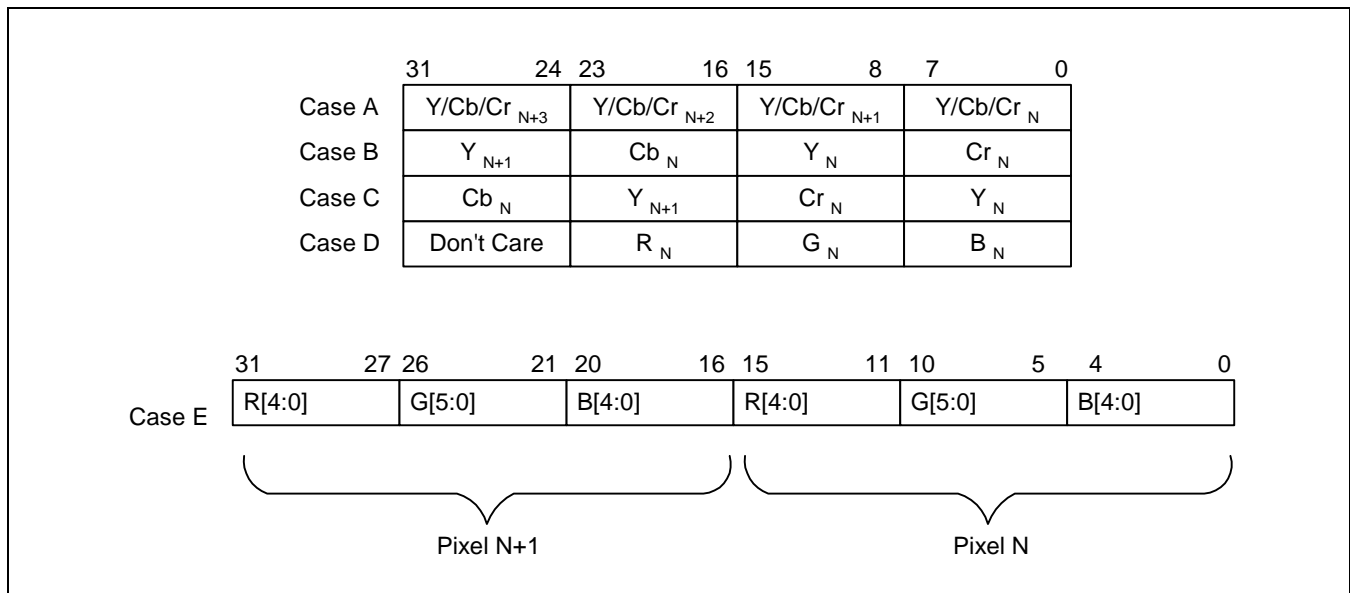
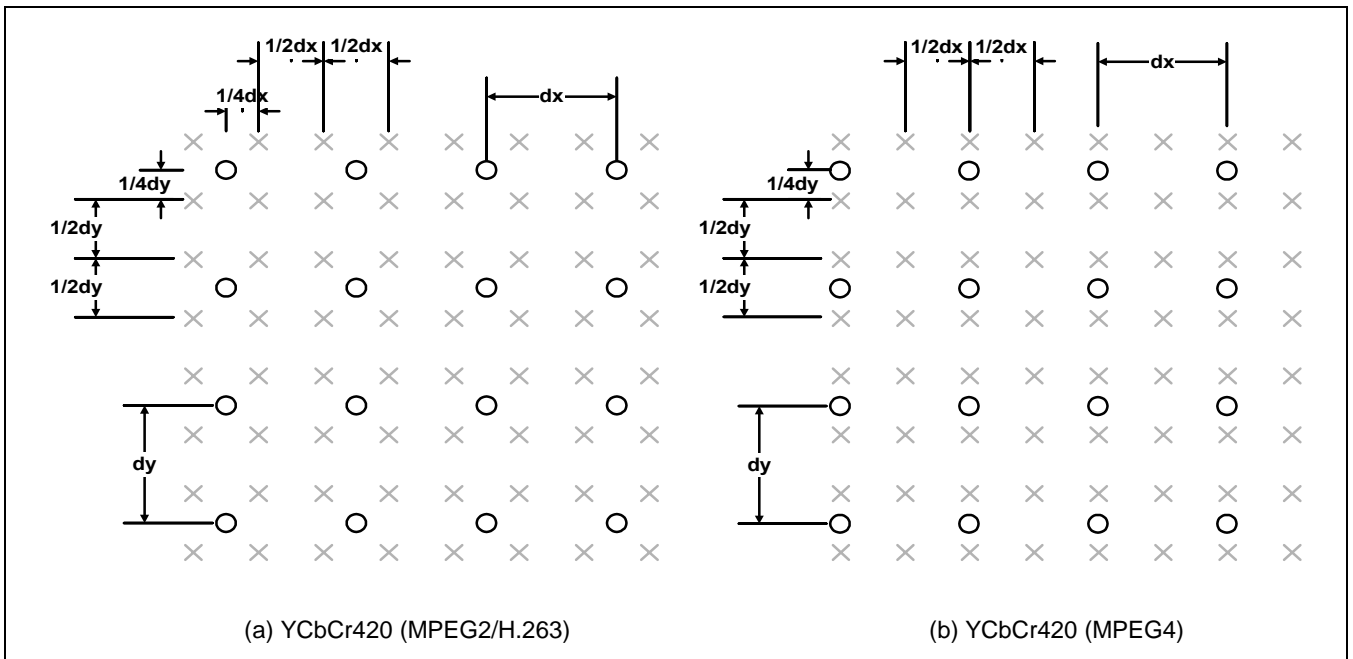
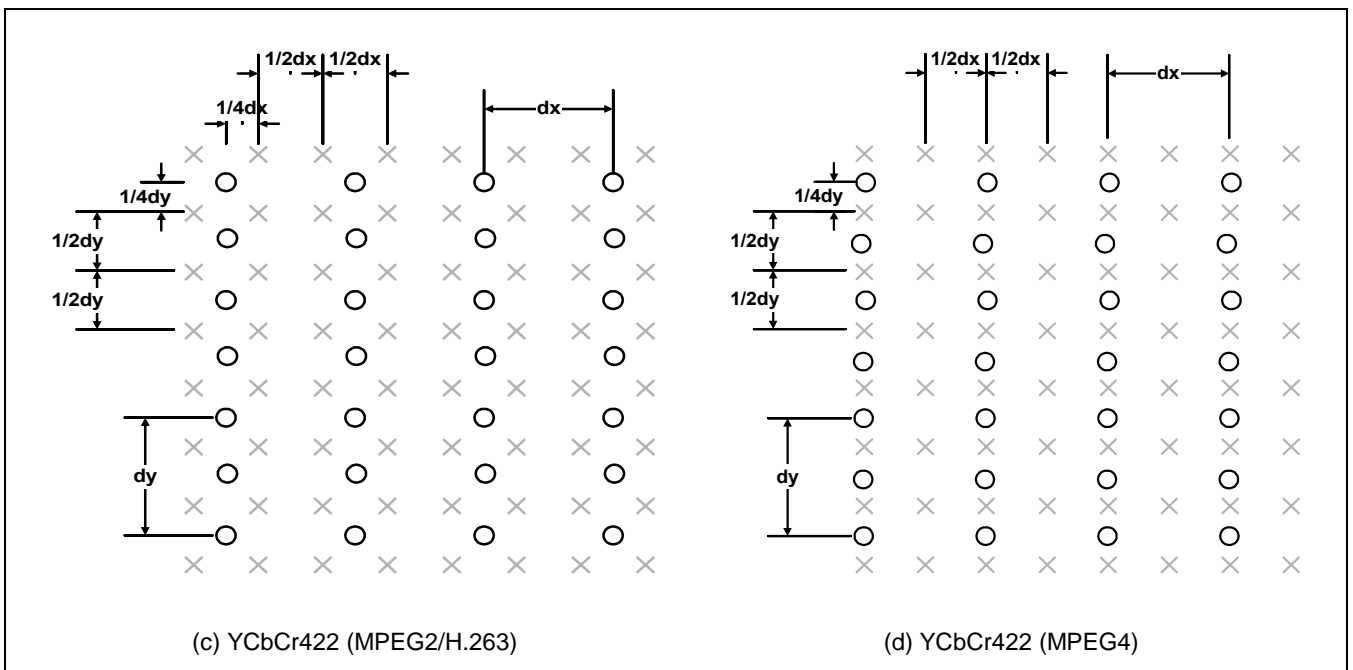

Figure 27-3. Byte and Half-Word Organization



(a) YCbCr420 (MPEG2/H.263)

(b) YCbCr420 (MPEG4)



(c) YCbCr422 (MPEG2/H.263)

(d) YCbCr422 (MPEG4)

Figure 27-4. Sampling Position of YCbCr420 and YCbCr422 Format  
(X: Luma Sample and O: Chroma Sample)

## IMAGE SIZE AND SCALE RATIO

The RGB graphic source image size is determined by number of pixels along to horizontal and vertical directions. YCbCr420 and YCbCr422 source image size is determined only by numbers of Y samples along to horizontal and vertical directions. Destination image size is determined by dimension of final RGB graphic image, after color space conversion if source image is YCbCr image.

As explained in the previous section, SRC\_Width and DST\_Width satisfy the word boundary constraints such that the number of horizontal pixel can be represented to  $kn$  where  $n = 1, 2, 3, \dots$  and  $k = 1 / 2 / 8$  for 24bppRGB / 16bppRGB / YCbCr420 image, respectively.

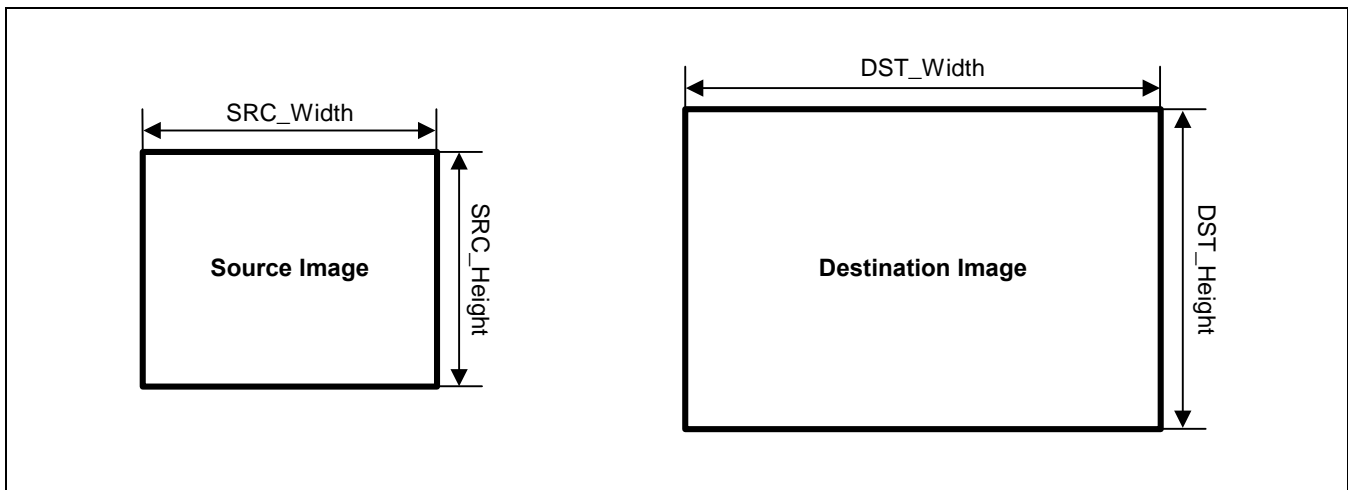

Figure 27-5. Source Destination Image Size

The other control registers of pre-scaled image size, pre-scale ratio, pre-scale shift ratio and main scale ratio are defined according to the following equations.

```

If ( SRC_Width >= 64 x DST_Width ) { Exit(-1); /* Out Of Horizontal Scale Range */ }
else if ( SRC_Width >= 32 x DST_Width ) { PreScale_H_Ratio = 32; H_Shift = 5; }
else if ( SRC_Width >= 16 x DST_Width ) { PreScale_H_Ratio = 16; H_Shift = 4; }
else if ( SRC_Width >= 8 x DST_Width ) { PreScale_H_Ratio = 8; H_Shift = 3; }
else if ( SRC_Width >= 4 x DST_Width ) { PreScale_H_Ratio = 4; H_Shift = 2; }
else if ( SRC_Width >= 2 x DST_Width ) { PreScale_H_Ratio = 2; H_Shift = 1; }
else { PreScale_H_Ratio = 1; H_Shift = 0; }

```

```
PreScale_DSTWidth = SRC_Width / PreScale_H_Ratio;
```

```
dx = ( SRC_Width << 8 ) / ( DST_Width << H_Shift );
```

```
If ( SRC_Height >= 64 × DST_Height ) { Exit(-1); /* Out Of Vertical Scale Range */ }
else if ( SRC_Height >= 32 × DST_Height ) { PreScale_V_Ratio = 32; V_Shift = 5; }
else if ( SRC_Height >= 16 × DST_Height ) { PreScale_V_Ratio = 16; V_Shift = 4; }
else if ( SRC_Height >= 8 × DST_Height ) { PreScale_V_Ratio = 8; V_Shift = 3; }
else if ( SRC_Height >= 4 × DST_Height ) { PreScale_V_Ratio = 4; V_Shift = 2; }
else if ( SRC_Height >= 2 × DST_Height ) { PreScale_V_Ratio = 2; V_Shift = 1; }
else { PreScale_V_Ratio = 1; V_Shift = 0; }
```

PreScale\_DSTHeight = SRC\_Height / PreScale\_V\_Ratio;

dy = ( SRC\_Height << 8 ) / ( DST\_Height << V\_Shift );

PreScale\_SHFactor = 10 - ( H\_Shift + V\_Shift );

### DMA OPERATION OF SOURCE AND DESTINATION IMAGE

There are three address categories such as start address, end address and offset address for DMA operation. Each address category consists of three source address components of Y/Cb/Cr and one destination address component of RGB. If a source image is stored by the non-interleaved format such as YCbCr420, all source address components are valid as shown in Figure 27-6 (a). If a source image is stored by the interleaved format such as a RGB graphic format or an YCbCr422 format, only Y component of three source components is valid and two chroma address components are invalid as shown in Figure 27-6 (b). The details of start and end address are define as follows.

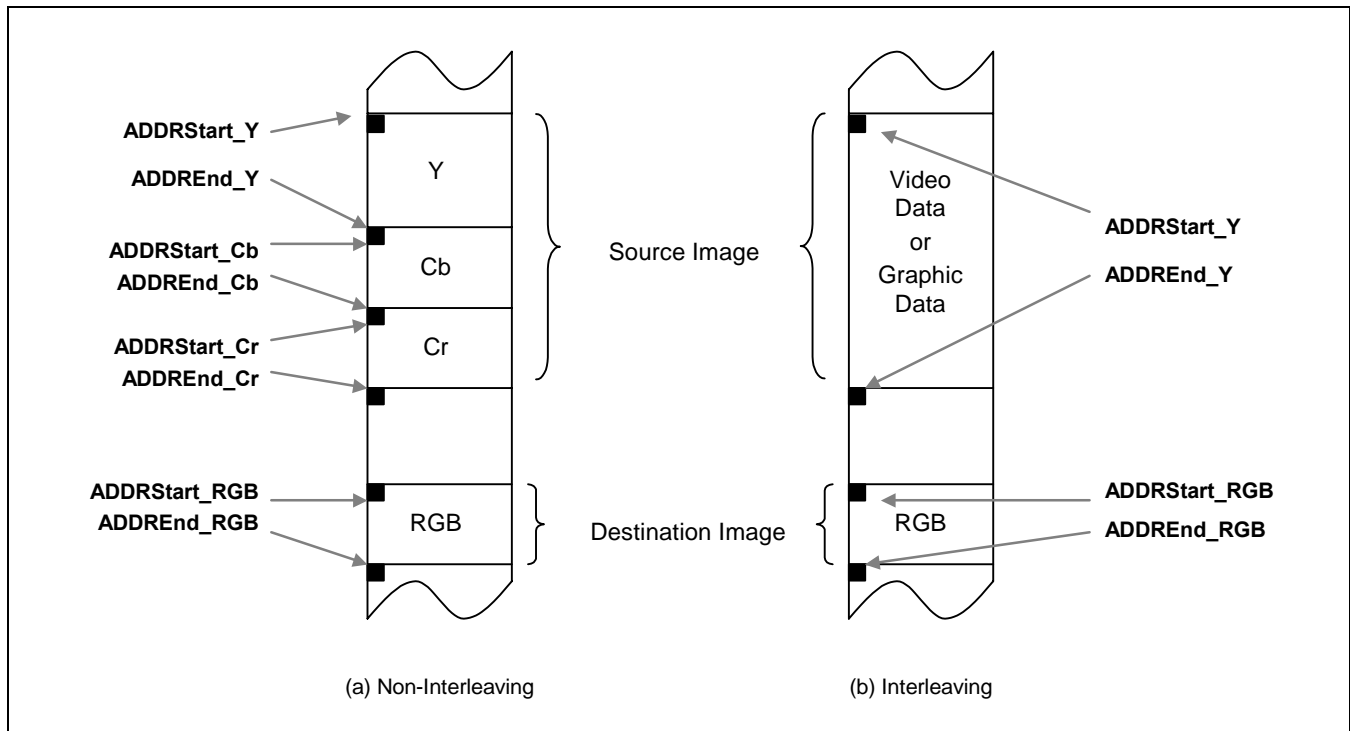

Figure 27-6. Start and End Address Set According to Memory Allocation Type

**Start Address**

Start address of ADDRStart\_Y/Cb/Cr/RGB points the first word address where the corresponding component of Y/Cb/Cr/RGB is read or written. Each one should be aligned with word boundary (i.e. ADDRStart\_X[1:0] = 00). ADDRStart\_Cb and ADDRStart\_Cr are valid only for the YCbCr420 source image format.

**End Address**

ADDREnd\_Y

= ADDRStart\_Y + Memory size for the component of Y

= ADDRStart\_Y + (SRC\_Width × SRC\_Height) × ByteSize\_Per\_Pixel + Offset\_Y × (SRC\_Height-1)

ADDREnd\_Cb (Valid for YCbCr420 source format)

= ADDRStart\_Cb + Memory size for the component of Cb

= ADDRStart\_Cb + (SRC\_Width/2 × SRC\_Height/2) × ByteSize\_Per\_Pixel + Offset\_Cb × (SRC\_Height/2-1)

ADDREnd\_Cr (Valid for YCbCr420 source format)

= ADDRStart\_Cr + Memory size for the component of Cr

= ADDRStart\_Cr + (SRC\_Width/2 × SRC\_Height/2) × ByteSize\_Per\_Pixel + Offset\_Cr × (SRC\_Height/2-1)

ADDREnd\_RGB

= ADDRStart\_RGB + Memory size for the component of RGB data

= ADDRStart\_RGB + (DST\_Width × DST\_Height) × ByteSize\_Per\_Pixel + Offset\_RGB × (DST\_Height-1)

Where,

Offset\_Y/Cb/Cr/RGB

= Memory size for offset per a horizontal line

= Number of pixel (or sample) in horizontal offset × ByteSize\_Per\_Pixel (or Sample)

ByteSize\_Per\_Pixel = 1 for YCbCr420

2 for 16-bit RGB and YCbCr422

4 for 24-bit RGB

Offset is used for the following two situations. One is to fetch some parts of source image in order to zoom in/out as shown in Figure 27-7 (a). The other is to restore destination image for PIP (picture-in-picture) applications as shown in Figure 27-7 (b). Of course, the word boundary constraints should be satisfied in both cases.

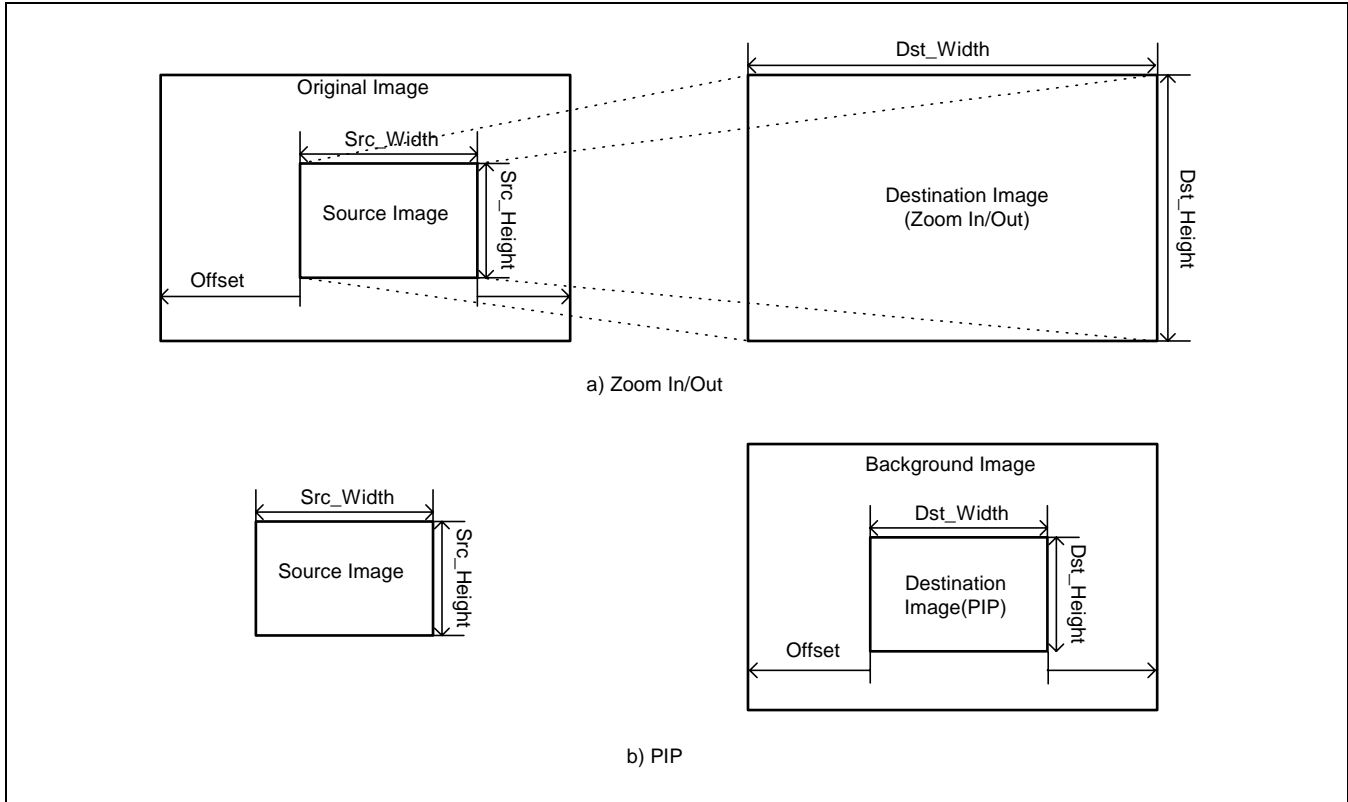

**Figure 27-7. Offset for (a) Source Image for Zoom In/Out Operation and (b) Destination Image for PIP Applications**



## STARTING AND TERMINATING OF POST PROCESSOR

Starting and terminating the operation of POST-Processor are controlled by two control register such as POSTENVID and POSTINT as shown in Figure 27-8. "POSTENVID" triggers the operation of POST PROCESSOR. It is automatically de-asserted when all operations of the given frame are completed. Before asserting "POSTENVID", all control registers should be set to the proper value as explained in the previous chapters. When all operations are completed, interrupt pending register is asserted (POSTINT=1), if interrupt enable signal is asserted (INTEN=1). The POSTINT signal, directing to the interrupt controller, should be cleared by the interrupt service routine. Otherwise, polling POSTENVID is used to detect the end of the operation.

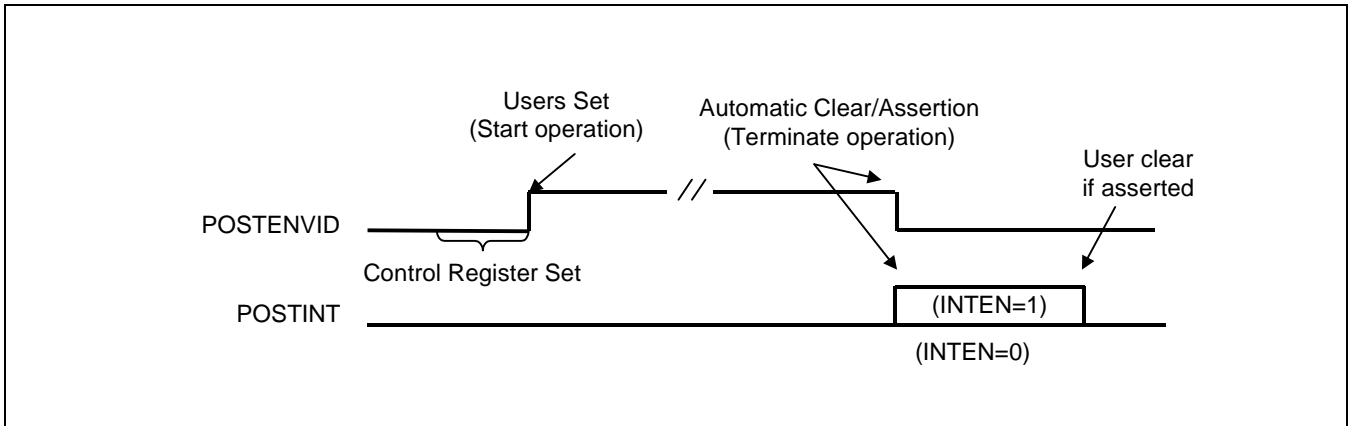

Figure 27-8. Start and Termination of the Operation of Post Processor

## REGISTER FILE LISTS

## Mode Control Register

Register	Address	R/W	Description	Reset Value
MODE	0X4A100000	R/W	Mode Register [9:0]	0xB12

Mode	Bit	Description	Initial State
Reserved	11	This bit should be '1'.	1
Reserved	10	This bit should be '0'.	0
MPEG4	[9]	Sampling position of chrome information. 0 for H.263/MPEG2 and 1 for MPEG4. It is valid only for YCbCr source image (i.e. InRGB = 0)	1
SRC420	[8]	0 for YCbCr422 and 1 for YCbCr420 source format. It is valid only for YCbCr source image (i.e. InRGB = 0)	1
INTEN	[7]	Interrupt Enable. It determines whether the POSTINT signal is asserted or not, when the processing of the current frame is finished. 0: disable, 1 : enable.	0
POSTINT	[6]	Interrupt Pending Bit. If INTEN is enabled, it is automatically asserted right after finishing operation of the current frame. It should be cleared by interrupt service routine. 0 : disable, 1 : enable.	0
POSTENVID	[5]	Enable Video Processing. It turns on the operation of Post Processor. It is de-asserted automatically after operation of the current frame is finished. It should be disabled (POSTENVID=0) during control register configuration state.	0
OutRGBFormat	[4]	It determines the output format of destination image. 0 for 16-bit (565 format) RGB and 1 for 24-bit RGB.	1
InRGB	[3]	It indicates the input color space of source image. 0 for YCbCr or 1 for RGB.	0
INTERLEAVE	[2]	It indicates the data format of YCbCr. 0 for Non-Interleaved format (Each component of Y, Cb and Cr is access by the word). 1 for Interleaved format (All components of Y, Cb and Cr are mixed inside single word). It should be 1 when source image is RGB data (or InRGB =1).	0
InRGBFormat	[1]	If the source image is in RGB color space (or InRGB=1), it indicates the data format of graphic image. 0 for 16-bit (565 format) and 1 for 24-bit. Otherwise (or InRGB=0), it should be remains to 1.	1
InYCbCrFormat	[0]	It determines the byte organization of word data when the source image is interleaved YCbCr format (InRGB=0 and INTERLEAVE=1). 0 for YCbYCr(type B in Fig. 27-2(b)) and 1 for CbYCrY (type C in Fig.27-2(b)) .	0

**Pre-Scale Ratio Register**

Register	Address	R/W	Description	Reset Value
PreScale_Ratio	0X4A100004	R/W	Pre-Scale ratio for vertical and horizontal.	0x0

PreScale_Ratio	Bit	Description	Initial State
PreScale_V_Ratio	[13:7]	Pre-scale ratio along to vertical direction (see chapter 27-3)	0x0
PreScale_H_Ratio	[6:0]	Pre-scale ratio along to horizontal direction (see chapter 27-3)	0x0

**PRE-SCALE IMAGE SIZE REGISTER**

Register	Address	R/W	Description	Reset Value
PreScaleImgSize	0X4A100008	R/W	Pre-Scaled image size	0x0

PreScaleImgSize	Bit	Description	Initial State
PreScale_DSTHeight	[23:12]	Pre-Scaled image height (see chapter 27-3)	0x0
PreScale_DSTWidth	[11:0]	Pre-Scaled image width (see chapter 27-3)	0x0

**SOURCE IMAGE SIZE REGISTER**

Register	Address	R/W	Description	Reset Value
SRClmgSize	0X4A10000C	R/W	Source image size	0x0

SRClmgSize	Bit	Description	Initial State
SRCHeight	[23:12]	Source image height (see chapter 27-3)	0x0
SRCWidth	[11:0]	Source image width (see chapter 27-3)	0x0

**Horizontal Main Scale Ratio Register**

Register	Address	R/W	Description	Reset Value
MainScale_H_Ratio	0X4A100010	R/W	Main scale ratio along to horizontal direction	0x0

MainScale_H_Ratio	Bit	Description	Initial State
MainScale_H_Ratio	[8:0]	Main scale ratio along to horizontal direction (see chapter 27-3)	0x0

**Vertical Main Scale Ratio Register**

Register	Address	R/W	Description	Reset Value
MainScale_V_Ratio	0X4A100014	R/W	Main scale ratio along to vertical direction	0x0

MainScale_V_Ratio	Bit	Description	Initial State
MainScale_V_Ratio	[8:0]	Main scale ratio along to vertical direction (see chapter 27-3)	0x0

**DESTINATION IMAGE SIZE REGISTER**

Register	Address	R/W	Description	Reset Value
DSTImgSize	0X4A100018	R/W	Destination image size	0x0

SRCImgSize	Bit	Description	Initial State
DSTHeight	[23:12]	Destination image height (see chapter 27-3)	0x0
DSTWidth	[11:0]	Destination image width (see chapter 27-3)	0x0

**Pre-Scale Shift Factor Register**

Register	Address	R/W	Description	Reset Value
PreScale_SHFactor	0X4A10001C	R/W	Pre-scale shift factor	0x0

SRC_Width	Bit	Description	Initial State
PreScale_SHFactor	[3:0]	Pre-scale shift factor (see chapter 27-3)	0x0

**DMA START ADDRESS REGISTER**

Register	Address	R/W	Bit	Description	Reset Value
ADDRStart_Y	0X4A100020	R/W	[30:0]	DMA Start address for Y or RGB component of source image	0x2000_0000

Register	Address	R/W	Bit	Description	Reset Value
ADDRStart_Cb	0X4A100024	R/W	[30:0]	DMA Start address for Cb component of source image	0x2000_0000

Register	Address	R/W	Bit	Description	Reset Value
ADDRStart_Cr	0X4A100028	R/W	[30:0]	DMA Start address for Cr component of source image	0x2000_0000

Register	Address	R/W	Bit	Description	Reset Value
ADDRStart_RGB	0X4A10002C	R/W	[30:0]	DMA Start address for RGB component of destination image	0x2000_0000



**DMA END ADDRESS REGISTER**

Register	Address	R/W	Bit	Description	Reset Value
ADDREnd_Y	0X4A100030	R/W	[30:0]	DMA End address for Y or RGB component of source image (see chapter 27-4)	0x2000_62fc

Register	Address	R/W	Bit	Description	Reset Value
ADDREnd_Cb	0X4A100034	R/W	[30:0]	DMA End address for Cb component of source image (see chapter 27-4)	0x2000_62fc

Register	Address	R/W	Bit	Description	Reset Value
ADDREnd_Cr	0X4A100038	R/W	[30:0]	DMA End address for Cr component of source image (see chapter 27-4)	0x2000_62fc

Register	Address	R/W	Bit	Description	Reset Value
ADDREnd_RGB	0X4A10003C	R/W	[30:0]	DMA End address for RGB component of destination image (see chapter 27-4)	0x2000_62fc

**OFFSET REGISTER**

Register	Address	R/W	Bit	Description	Reset Value
Offset_Y	0X4A100040	R/W	[23:0]	Offset of Y component for fetching source image (see chapter 27-4)	0

Register	Address	R/W	Bit	Description	Reset Value
Offset_Cb	0X4A100044	R/W	[23:0]	Offset of Cb component for fetching source image (see chapter 27-4)	0

Register	Address	R/W	Bit	Description	Reset Value
Offset_Cr	0X4A100048	R/W	[23:0]	Offset of Cr component for fetching source image (see chapter 27-4)	0

Register	Address	R/W	Bit	Description	Reset Value
Offset_RGB	0X4A10004C	R/W	[23:0]	Offset of RGB component for restoring destination image (see chapter 27-4)	0

# 28

## LCD CONTROLLER

### OVERVIEW

The LCD controller with S3C24A0A consists of logic for transferring LCD image data from a video buffer located in system memory to an external LCD driver.

The LCD controller supports 1-bit per pixel, 2-bit per pixel, 4-bit per pixel, 8-bit per pixel for interfacing with the palletized TFT color LCD panel, 8-bit, 16-bit per pixel and 18-bit per pixel non-palletized color display.

The LCD controller can be programmed to support the different requirements on the screen related to the number of horizontal and vertical pixels, data line width for the data interface, interface timing, and refresh rate.

### FEATURES

Video Clock Source	HCLK
External Panel Interface	Supports up to 18 bit RGB I/F Panel (RGB Parallel mode) Supports 6 bit RGB I/F Panel (RGB Serial mode) Supports both RGB and BGR mode
OSD(Overlay)	Supports 8 BPP (bit per pixel) palettized or non-palettized color displays for TFT Supports 16 and 18 BPP non-palettized color displays for color TFT
	Supports X,Y indexed position
	Supports 8 bit Alpha blending: per Plan or per Pixel (18 BPP only)
	Support 18 bit Color Key function
Color Level of TFT	Supports 1, 2, 4 and 8 BPP (bit per pixel) palettized color displays for TFT
	Supports 8, 16 and 18 BPP non-palettized color displays for TFT
Display Size	Supports 640x480, 320x240, 176x192 and others
Configurable Burst Length	Support programmable 4 / 8 / 16 Burst DMA operation
Dual Palette	256 x 24 bit palette (2ea for each Background and Foreground image)
Soft Scrolling	Horizontal: 1 Byte resloution Vertical: 1 pixel resolution
Virtual Screen	Virtual image can has up to 16MB image size.
Double Buffering	Frame buffer alternating by one control bit
Dithering	Patented 4x4 dither matrix implemetation

**EXTERNAL INTERFACE SIGNAL**

<b>Name</b>	<b>Type</b>	<b>Source/Destination</b>	<b>Description</b>
XvVCLK	Output	Pad	Video Clock Signal
XvHSYNC	Output	Pad	Horizontal Sync. Signal
XvVSYNC	Output	Pad	Vertical Sync. Signal
XvVDEN	Output	Pad	Video Data Enable/Valid
XvVD[17:12]	Output	Pad	LCD pixel data output for Red in RGB Parallel Mode LCD pixel data output in RGB Serial Mode
XvVD[11:6]	Output	Pad	LCD pixel data output for Green in RGB Parallel Mode
XvVD[5:0]	Output	Pad	LCD pixel data output for Blue in RGB Parallel Mode



## BLOCK DIAGRAM

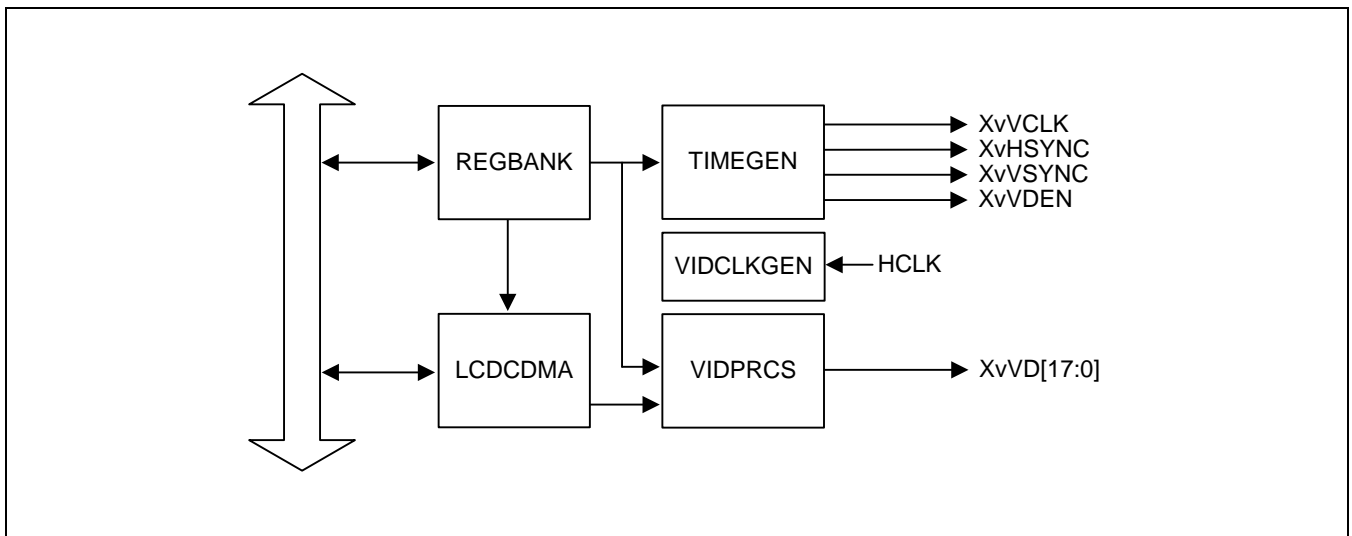

Figure 28-1. LCD Controller Block Diagram

The LCD controller with S3C24A0A is used to transfer the video data and to generate the necessary control signals such as, XvVSYNC, XvHSYNC, XvVCLK, and XvVDEN. As well as the control signals, S3C24A0A has the data ports for video data, which are XvVD[17:0] as shown in Figure 28-1. The LCD controller consists of a REG BANK, LCDCDMA, VIDPRCS, TIMEGEN, and VIDCLKGEN (See Figure 28-1 LCD Controller Block Diagram). The REG BANK has 26 programmable register sets and 256x24 palette memory which are used to configure the LCD controller. The LCDCDMA is a dedicated DMA, which it can transfer the video data in frame memory to LCD driver, automatically. By using this special DMA, the video data can be displayed on the screen without CPU intervention. The VIDPRCS receives the video data from LCDCDMA and sends the video data through the VD[17:0] data ports to the LCD driver after changing them into a suitable data format, for example 8-bit per pixel mode(8 BPP Mode) or 16-bit per pixel mode(16 BPP Mode). The TIMEGEN consists of programmable logic to support the variable requirement of interface timing and rates commonly found in different LCD drivers. The TIMEGEN block generates, XvVSYNC, XvHSYNC, XvVCLK, and XvVDEN.

The description of data flow is as follows:

FIFO memory is present in the LCDCDMA. When FIFO is empty or partially empty, LCDCDMA requests data fetching from the frame memory based on the burst memory transfer mode(Consecutive memory fetching of 4 / 8 / 16 words per one burst request without allowing the bus mastership to another bus master during the bus transfer). When this kind of transfer request is accepted by bus arbitrator in the memory controller, there will be 4 / 8 / 16 successive word data transfers from system memory to internal FIFO. The total sizes of FIFO are 128x2 words, which consist of 128 words for background FIFO and 128 words foreground FIFO, respectively. The S3C24A0A has two FIFOs because it needs to support the OSD display mode. In case of one screen display mode, the background FIFO could only be used.

LCD controller supports overlay function which enables overlaying any image (OSD, foreground image) which is small or same size can be blended with background image with programmable alpha blending or color (chroma) key function.

## TIMING CONTROLLER OPERATION

The TIMEGEN generates the control signals for LCD driver such as , XvVSYNC, XvHSYNC, XvVCLK, and XvVDEN signal. These control signals are highly related with the configuration on the LCDTCON1/2/3 registers in the REGBANK. Base on these programmable configurations on the LCD control registers in REGBANK, the TIMEGEN can generate the programmable control signals suitable for the support of many different types of LCD drivers.

The VSYNC signal is asserted to cause the LCD's line pointer to start over at the top of the display.

The generation of VSYNC and HSYNC pulse is controlled by the configuration of both the HOZVAL field and the LINEVAL field in the LCDTCON3 register. The HOZVAL and LINEVAL can be determined by the size of the LCD panel according to the following equations:

$$\text{HOZVAL} = (\text{Horizontal display size}) - 1$$

$$\text{LINEVAL} = (\text{Vertical display size}) - 1$$

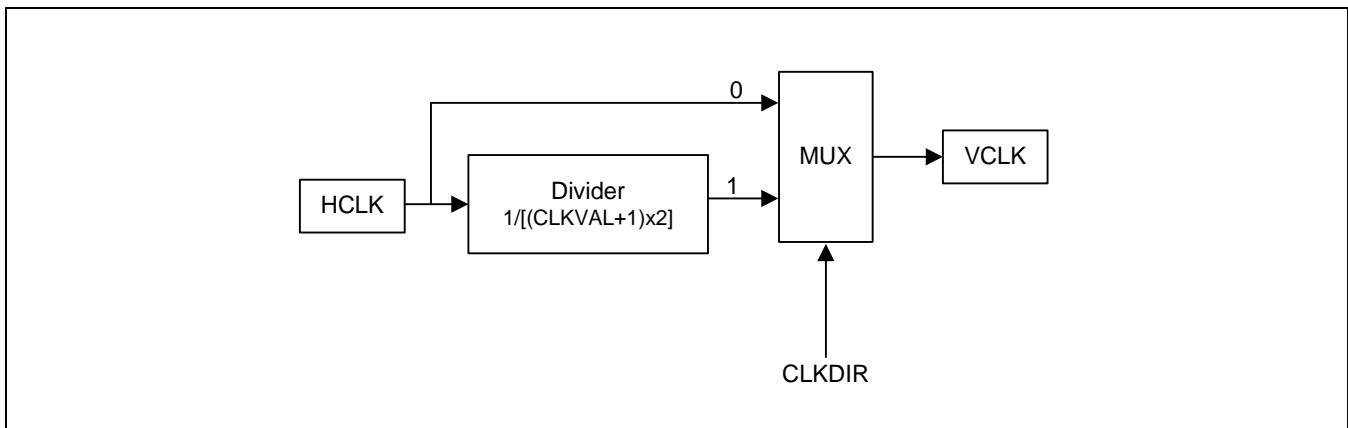

Figure 28-2. Clock Selection

The rate of VCLK signal can be controlled by the CLKVAL field in the LCDCON1 register. The table below defines the relationship of VCLK and CLKVAL. The minimum value of CLKVAL is 0.

$$\text{XvVCLK (Hz)} = \text{HCLK} / [(\text{CLKVAL} + 1) \times 2]$$

The frame rate is VSYNC signal frequency. The frame rate is related with the field of VSYNC, VBPD, VFPD, LINEVAL, HSYNC, HBPD, HFPD, HOZVAL, CLKVAL registers. Most LCD driver needs their own adequate frame rate. The frame rate is calculated as follows;

$$\text{Frame Rate} = 1 / [ \{ (\text{VSPW} + 1) + (\text{VBPD} + 1) + (\text{LINEVAL} + 1) + (\text{VFPD} + 1) \} \times \{ (\text{HSPW} + 1) + (\text{HBPD} + 1) + (\text{HFPD} + 1) + (\text{HOZVAL} + 1) \} \times \{ 2 \times (\text{CLKVAL} + 1) / (\text{Frequency of Clock source}) \} ]$$

Table 28-1. Relation Between XvCLK and CLKVAL (TFT, Freq. of Video Clock Source = 60 MHz)

CLKVAL	60 MHz/X	XvCLK
1	60 MHz/4	15.0 MHz
2	60 MHz/6	10.0 MHz
:	:	:
63	60 MHz/128	492 kHz

## VIDEO OPERATION

The TFT LCD controller within S3C24A0A supports 1, 2, 4 or 8 BPP(bit per pixel) palettized color displays and 8, 16 non-palettized high-color or 18 BPP non-palettized true-color displays. The TFT LCD controller also supports On-Screen Display with 256-level alpha blending and color (chroma) key functions. The background image and foreground image (OSD image) should have a frame buffer of each image.

### OSD (ON-SCREEN DISPLAY): OVERLAY

OSD (On Screen Display) and blending operation as shown in Fig 28-3 are established for video overlay or other graphics applications. Two blending schemes are provided according to the control bit of OSD\_BLD\_PIX. One is per-pixel blending for 18 BPP mode display (OSD\_BLD\_PIX = 1) and the other is per-plane bending for 8/16/18 BPP mode display (OSD\_BLD\_PIX = 0). LCDB1ADDR1/2/3, LCDB2ADDR1/2/3 registers are defined to perform DMA for OSD image. Four screen coordinates such as OSD\_LEFT\_TOP\_X, OSD\_LEFT\_TOP\_Y, OSD\_RIGHT\_BOT\_X and OSD\_RIGHT\_BOT\_Y determines where the OSD image is located on the whole background image. The level of blending is controller by OSD\_ALPHA as following manner.

<Equation 28-1>

$$\text{New Pixel} = (1-\text{Alpha}) \times \text{Background Pixel} + \text{Alpha} \times \text{Foreground Pixel}$$

Where, Alpha = 0, if OSD\_ALPHA[7:0] = 0.

$$\text{Alpha} = \sum_{i=1,2,\dots,7} \text{OSD\_ALPHA}[7-i] \times 2^{-i} \times \text{OSD\_ALPHA}[7-i], \text{ other.}$$

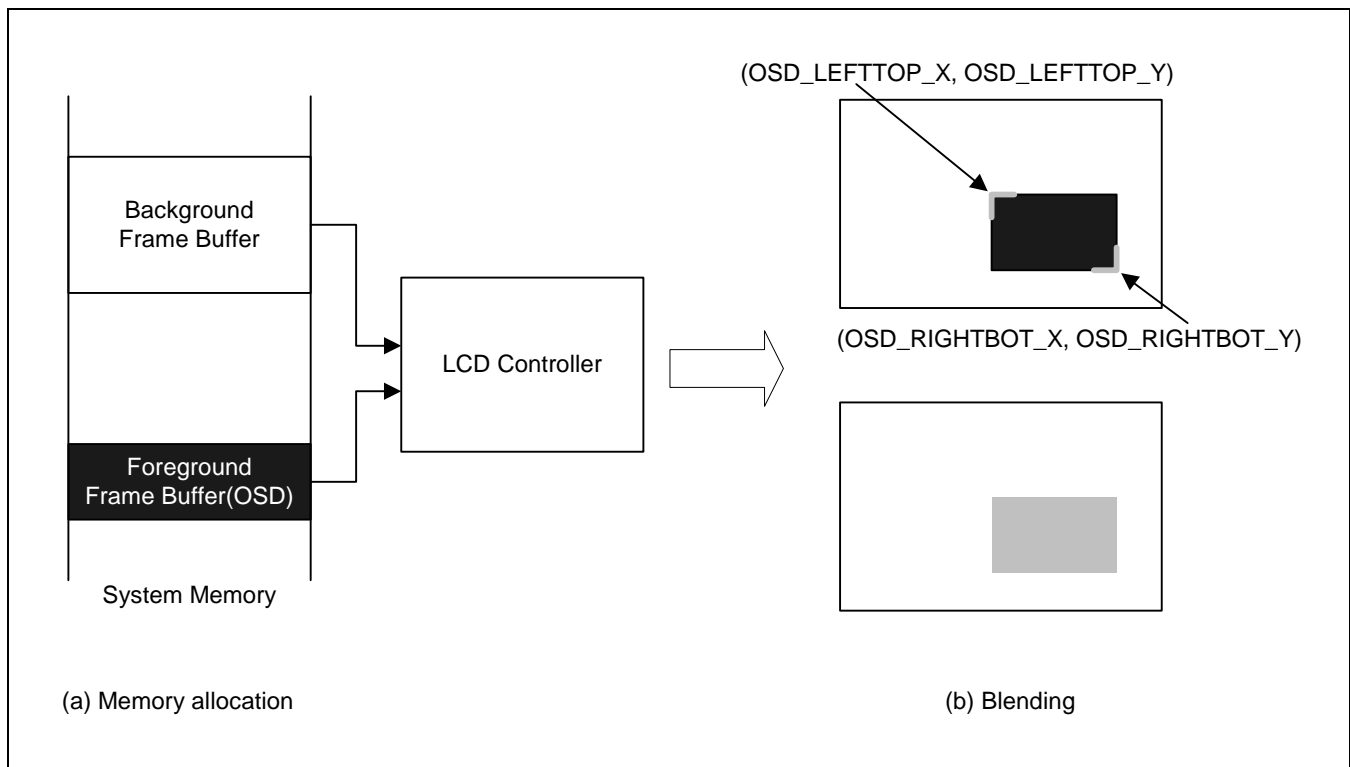

Figure 28-3. OSD Procedure

### COLOR-KEY FUNCTION

The S3C24A0A can support color-key function for the various effect of image mapping. Color image, which is specified by COLOR-KEY register, of OSD layer will be substituted by background image for special functionality, as cursor image or pre-view image of the camera.

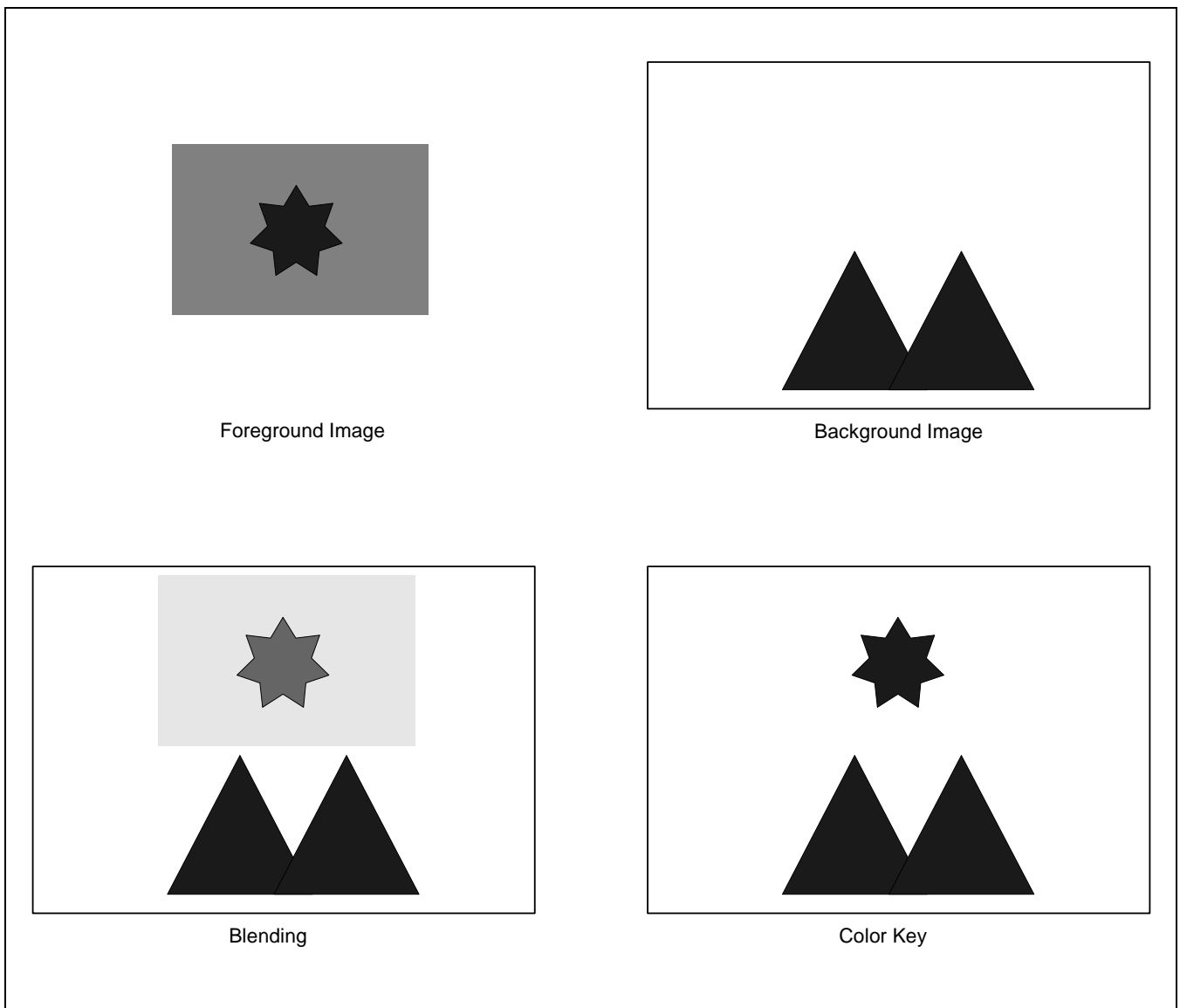

Figure 28-4. Blending and Color Key Function of OSD

## DUAL BUFFER

The S3C24A0A LCD controller supports easy and fast way for the dual buffering of frame image.

User can take two frame image buffer and select one for active frame buffer using the BDBCON (Background double buffer control) and FDBCON (Foreground double buffer control) register. Pre-defined address sets of frame buffer 1 and frame buffer2 are described at Frame Buffer Register 1,2,3. So, user can select which buffer will be activated by setting of the BDBCON and FDBCON register. Maybe, some applications should need simple changing method of frame buffer namely "ping-pong display". Pre-view image of camera interface will be good example of dual buffering method. One frame should be used as a display buffer, and the other frame as a updating buffer by camera interface module.

**Memory Data Format (TFT)**

The LCD controller requests the specified memory format of frame buffer. The next table shows some examples of each display mode.

**18 BPP Display**

[BSWP = 0, HWSWP = 0]

	D[31:24]	D[23:0]
000H	Alpha1	P1
004H	Alpha2	P2
008H	Alpha3	P3
...		

**NOTE:** D[31:24] are used to be the alpha value according to each pixel data when blending mode is per-pixel at 18 BPP. So, user must write appropriate value to this filed.

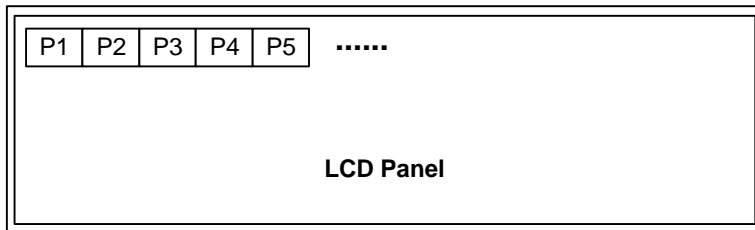

[Memory Storing Order at 18 BPP]

D[23:0]	23	22	21	20	19	18	17	16	15	14	13	12	11	10	9	8	7	6	5	4	3	2	1	0
Data	R5	R4	R3	R2	R1	R0	x	x	G5	G4	G3	G2	G1	G0	x	x	B5	B4	B3	B2	B1	B0	x	x

x: Don't care, We recommend that those bits are filled with '0'.

[XvVD Pin Connection at 18 BPP/Parallel Mode]

XvVD	17	16	15	14	13	12	11	10	9	8	7	6	5	4	3	2	1	0
Data	R5	R4	R3	R2	R1	R0	G5	G4	G3	G2	G1	G0	B5	B4	B3	B2	B1	B0

[XvVD Pin Connection at 18 BPP/Serial Mode]

XvVD	17	16	15	14	13	12	11 - 0
1 <sup>st</sup> Data	R5	R4	R3	R2	R1	R0	NC
2 <sup>nd</sup> Data	G5	G4	G3	G2	G1	G0	NC
3 <sup>rd</sup> Data	B5	B4	B3	B2	B1	B0	NC

**16BPP Display**

[BSWP = 0, HWSWP = 0]

	D[31:16]	D[15:0]
000H	P1	P2
004H	P3	P4
008H	P5	P6
...		

[BSWP = 0, HWSWP = 1]

	D[31:16]	D[15:0]
000H	P2	P1
004H	P4	P3
008H	P6	P5
...		

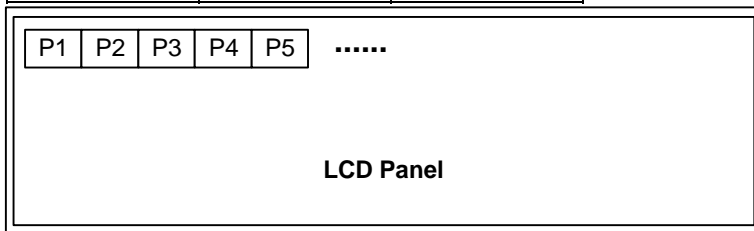

[Memory Storing Method at 16 BPP]

**(5:6:5)**

D[15:0]	15	14	13	12	11	10	9	8	7	6	5	4	3	2	1	0
Data	R4	R3	R2	R1	R0	G5	G4	G3	G2	G1	G0	B4	B3	B2	B1	B0

**(5:5:5:1)**

D[15:0]	15	14	13	12	11	10	9	8	7	6	5	4	3	2	1	0
Data	R4	R3	R2	R1	R0	G4	G3	G2	G1	G0	B4	B3	B2	B1	B0	I

[XvVD Pin Connection at 16 BPP/Parallel Mode]

**(5:6:5)**

XvVD	17	16	15	14	13	12	11	10	9	8	7	6	5	4	3	2	1	0
Data	R4	R3	R2	R1	R0	NC	G5	G4	G3	G2	G1	G0	B4	B3	B2	B1	B0	NC

**(5:5:5:1)**

XvVD	17	16	15	14	13	12	11	10	9	8	7	6	5	4	3	2	1	0
Data	R4	R3	R2	R1	R0	I	G4	G3	G2	G1	G0	I	B4	B3	B2	B1	B0	I



[XvVD Pin Connection at 16 BPP/Serial Mode]

(5:6:5)

XvVD	17	16	15	14	13	12	11 - 0
1 <sup>st</sup> Data	R4	R3	R2	R1	R0	NC	NC
2 <sup>nd</sup> Data	G5	G4	G3	G2	G1	G0	NC
3 <sup>rd</sup> Data	B4	B3	B2	B1	B0	NC	NC

(5:5:5:1)

XvVD	17	16	15	14	13	12	11 - 0
1 <sup>st</sup> Data	R4	R3	R2	R1	R0	I	NC
2 <sup>nd</sup> Data	G4	G3	G2	G1	G0	I	NC
3 <sup>rd</sup> Data	B4	B3	B2	B1	B0	I	NC

**8BPP Display**

[BSWP = 0, HWSWP = 0]

	D[31:24]	D[23:16]	D[15:8]	D[7:0]
000H	P1	P2	P3	P4
004H	P5	P6	P7	P8
008H	P9	P10	P11	P12
...				

[BSWP = 1, HWSWP = 0]

	D[31:24]	D[23:16]	D[15:8]	D[7:0]
000H	P4	P3	P2	P1
004H	P8	P7	P6	P5
008H	P12	P11	P10	P9
...				

**[Memory Storing Method at Non-palettized 8 BPP]**

D[7:0]	7	6	5	4	3	2	1	0
Data	R2	R1	R0	G2	G1	G0	B1	B0

[XvVD Pin Connection at Non-palettized 8BPP/Parallel Mode]

XvVD	17	16	15	14	13	12	11	10	9	8	7	6	5	4	3	2	1	0
Data	R2	R1	R0	NC	NC	NC	G2	G1	G0	NC	NC	NC	B1	B0	NC	NC	NC	NC

[XvVD Pin Connection at Non-palettized 8BPP/Serial Mode]

XvVD	17	16	15	14	13	12	11 - 0
1 <sup>st</sup> Data	R2	R1	R0	NC	NC	NC	NC
2 <sup>nd</sup> Data	G2	G1	G0	NC	NC	NC	NC
3 <sup>rd</sup> Data	B1	B0	NC	NC	NC	NC	NC



**4BPP Display**

[BSWP = 0, HWSWP = 0]

	D[31:28]	D[27:24]	D[23:20]	D[19:16]	D[15:12]	D[11:8]	D[7:4]	D[3:0]
000H	P1	P2	P3	P4	P5	P6	P7	P8
004H	P9	P10	P11	P12	P13	P14	P15	P16
008H	P17	P18	P19	P20	P21	P22	P23	P24
...								

[BSWP = 1, HWSWP = 0]

	D[31:28]	D[27:24]	D[23:20]	D[19:16]	D[15:12]	D[11:8]	D[7:4]	D[3:0]
000H	P7	P8	P5	P6	P3	P4	P1	P2
004H	P15	P16	P13	P14	P11	P12	P9	P10
008H	P23	P24	P21	P22	P19	P20	P17	P18
...								

**2BPP Display**

[BSWP = 0, HWSWP = 0]

D	[31:30]	[29:28]	[27:26]	[25:24]	[23:22]	[21:20]	[19:18]	[17:16]
000H	P1	P2	P3	P4	P5	P6	P7	P8
004H	P17	P18	P19	P20	P21	P22	P23	P24
008H	P33	P34	P35	P36	P37	P38	P39	P40
...								

D	[15:14]	[13:12]	[11:10]	[9:8]	[7:6]	[5:4]	[3:2]	[1:0]
000H	P9	P10	P11	P12	P13	P14	P15	P16
004H	P25	P26	P27	P28	P29	P30	P31	P32
008H	P41	P42	P43	P44	P45	P46	P47	P48
...								



## 256 PALETTE USAGE (TFT)

### Palette Configuration and Format Control

The S3C24A0A can support the 256 colors palette for various selection of color mapping. The user can select 256 colors from the 24-bit palette data through these three formats. 256 color palette consist of the 256(depth) × 24-bit SPSRAM. Palette supports 6:6:6, 5:6:5(R:G:B), and 5:5:5:1(R:G:B:I) format. When the user use 5:5:5:1 format, the intensity data(I) is used as a common LSB bit of each RGB data. So, 5:5:5:1 format is same as (5+I):G(5+I):B(5+I) format. For example of 5:5:5:1 format, write palette like Table 28-4 and then connect VD pin to TFT LCD panel(R(5+I)=VD[17:13]+VD[12], VD[6] or VD[0], G(5+I)=VD[11:7]+ VD[12], VD[6] or VD[0], B(5+I)=VD[5:1]+ VD[12], VD[6] or VD[0].) At the last, Set PALFRM register to 0x3.

**Table 28-2. 6:6:6 Palette Data Format**

INDEX\Bit Pos.	23-18	17	16	15	14	13	12	11	10	9	8	7	6	5	4	3	2	1	0
00H	–	R5	R4	R3	R2	R1	R0	G5	G4	G3	G2	G1	G0	B5	B4	B3	B2	B1	B0
01H	–	R5	R4	R3	R2	R1	R0	G5	G4	G3	G2	G1	G0	B5	B4	B3	B2	B1	B0
.....	–	...	...	...	...	...	...	...	...	...	...	...	...	...	...	...	...	...	...
FFH	–	R5	R4	R3	R2	R1	R0	G5	G4	G3	G2	G1	G0	B5	B4	B3	B2	B1	B0
<b>Number of VD</b>	–	17	16	15	14	13	12	11	10	9	8	7	6	5	4	3	2	1	0

**Table 28-3. 5:6:5 Palette Data Format**

INDEX\Bit Pos.	23-16	15	14	13	12	11	10	9	8	7	6	5	4	3	2	1	0
00H	–	R4	R3	R2	R1	R0	G5	G4	G3	G2	G1	G0	B4	B3	B2	B1	B0
01H	–	R4	R3	R2	R1	R0	G5	G4	G3	G2	G1	G0	B4	B3	B2	B1	B0
.....	–	...	...	...	...	...	...	...	...	...	...	...	...	...	...	...	...
FFH	–	R4	R3	R2	R1	R0	G5	G4	G3	G2	G1	G0	B4	B3	B2	B1	B0
<b>Number of VD</b>	–	17	16	15	14	13	11	10	9	8	7	6	5	4	3	2	1

**Table 28-4. 5:5:5:1 Palette Data Format**

INDEX\Bit Pos.	23-16	15	14	13	12	11	10	9	8	7	6	5	4	3	2	1	0
00H	–	R4	R3	R2	R1	R0	G4	G3	G2	G1	G0	B4	B3	B2	B1	B0	I
01H	–	R4	R3	R2	R1	R0	G4	G3	G2	G1	G0	B4	B3	B2	B1	B0	I
.....	–	...	...	...	...	...	...	...	...	...	...	...	...	...	...	...	...
FFH	–	R4	R3	R2	R1	R0	G4	G3	G2	G1	G0	B4	B3	B2	B1	B0	I
<b>Number of VD</b>	–	17	16	15	14	13	11	10	9	8	7	5	4	3	2	1	1)

#### NOTES:

1. VD12, VD6 and VD0 has same output value, I.
2. DATA[31:24] is invalid.

### Palette Read/Write

It is prohibited to access Palette memory during the ACTIVE status of the VSTATUS (vertical status) of LCDCON2 register. When the user going to do Read/Write operation on the palette, VSTATUS must be checked.

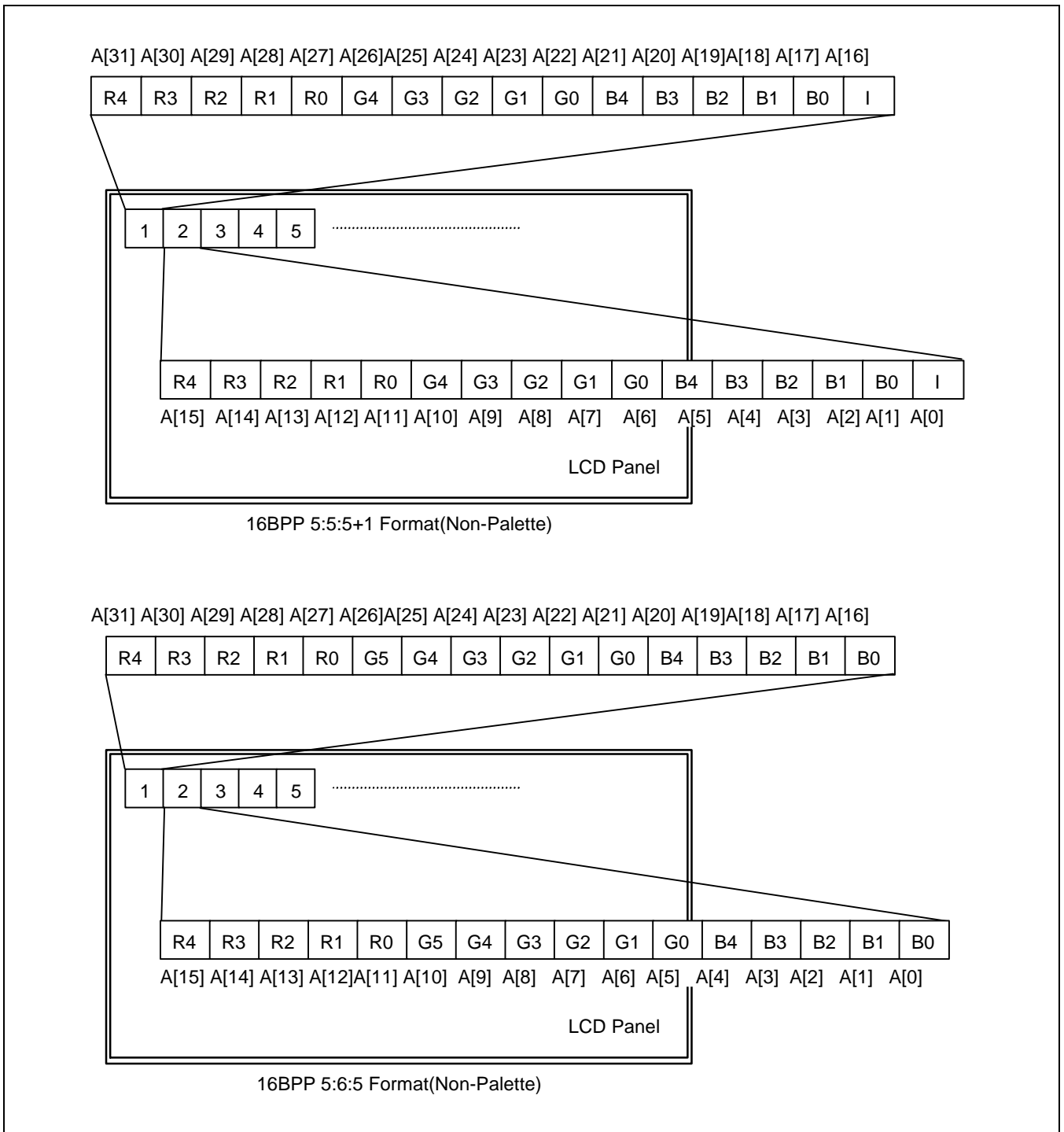

Figure 28-5. 16BPP Display Types

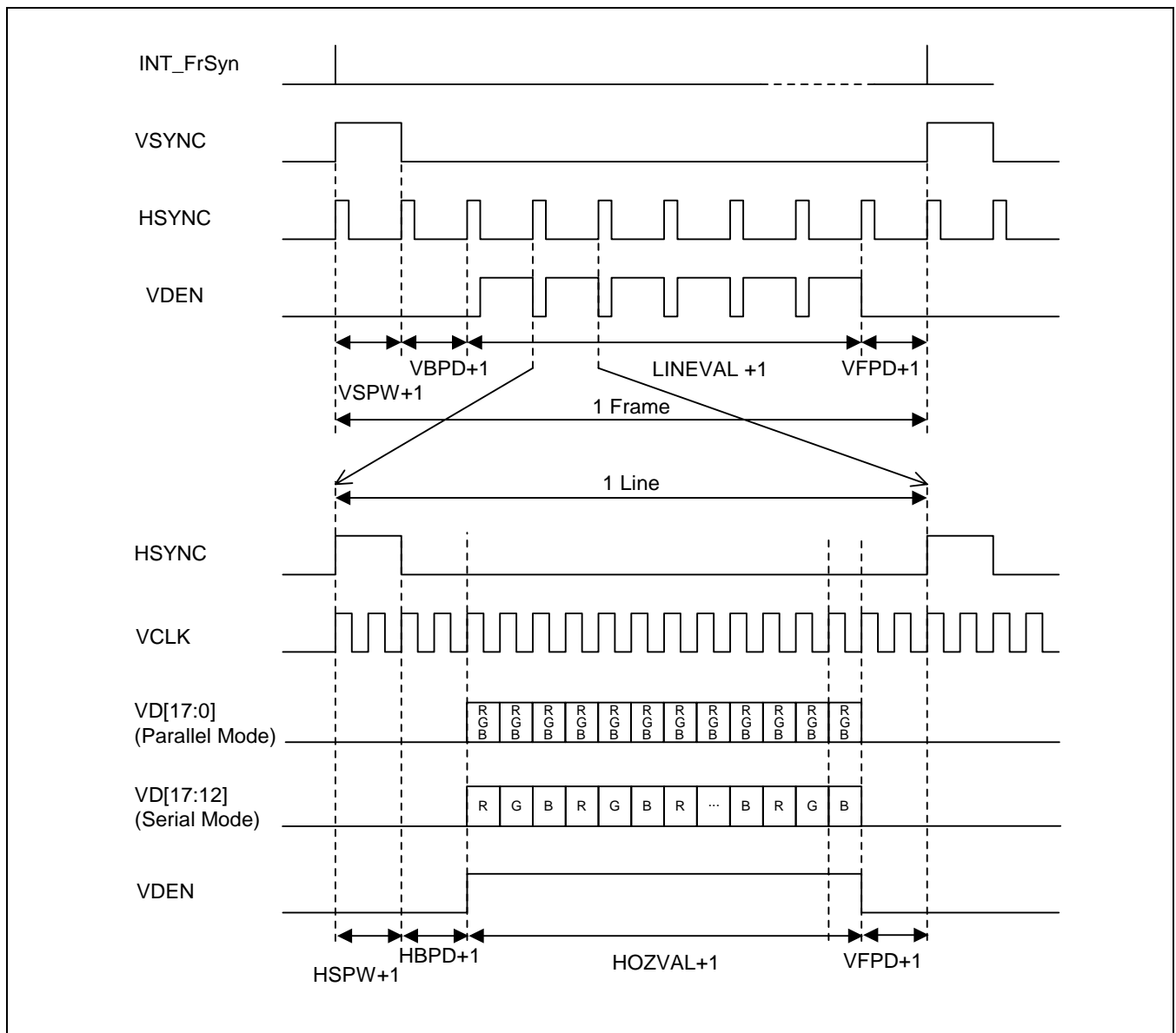
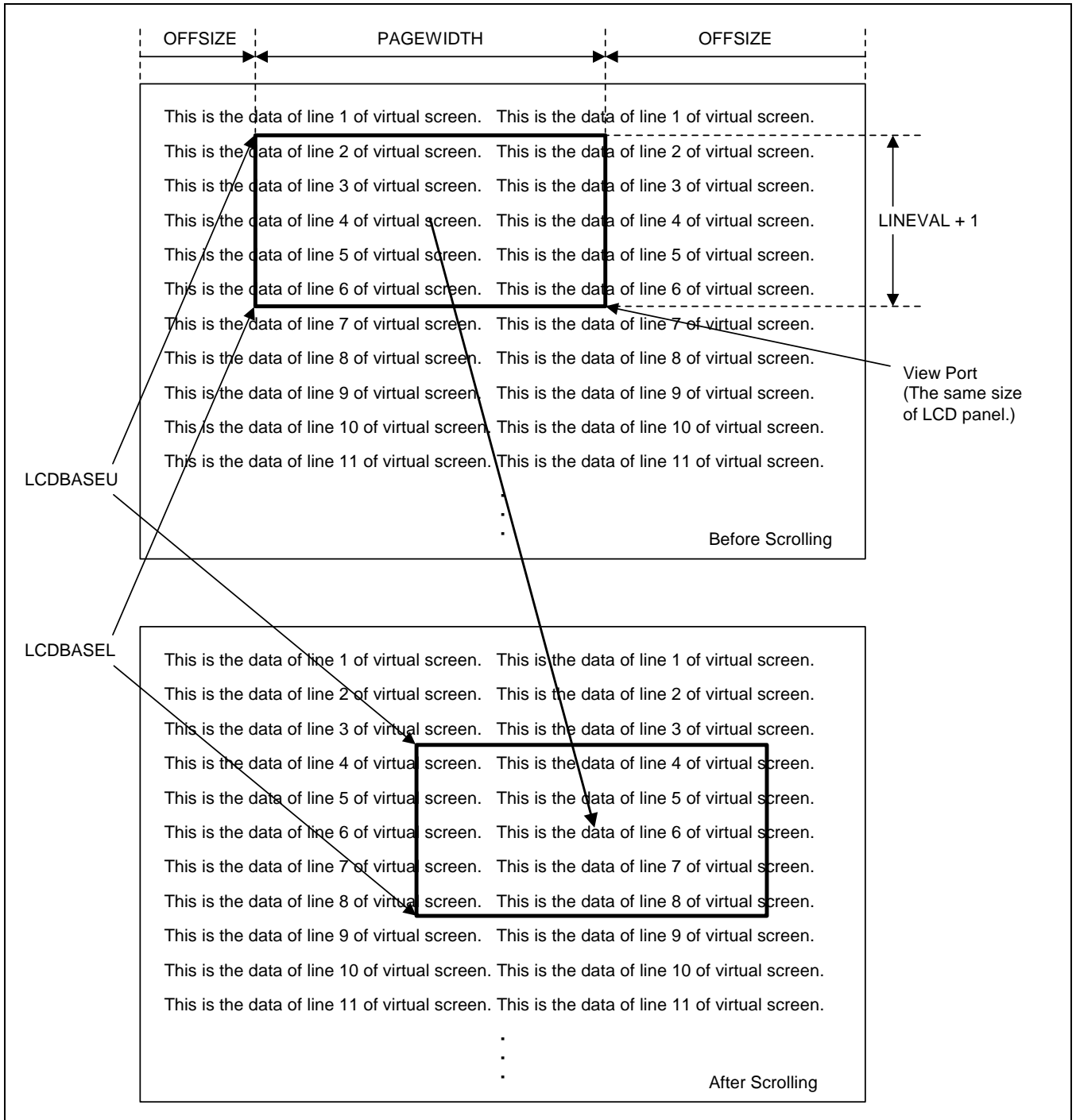

Figure 28-6. TFT LCD Timing Example

**VIRTUAL DISPLAY**

The S3C24A0A supports hardware horizontal or vertical scrolling. If the screen is scrolled, the fields of LCDBASEU and LCDBASEL registers need to be changed(refer to Figure 28-7) but not the values of PAGEWIDTH and OFFSIZE. The size of video buffer in which the image is stored should be larger than LCD panel screen size.



**Figure 28-7. Example of Scrolling in Virtual Display**



**REGISTER DESCRIPTION****MEMORY MAP**

Table 28-5. Configuration registers

Register	Address	R/W	Description	Reset Value
LCDCON1	0X4A000000	R/W	LCD Control 1	0x00000000
LCDCON2	0X4A000004	R/W	LCD Control 2	0x00000000
LCDTCON1	0X4A000008	R/W	LCD Time Control 1	0x00000000
LCDTCON2	0X4A00000C	R/W	LCD Time Control 2	0x00000000
LCDTCON3	0X4A000010	R/W	LCD Time Control 3	0x00000000
LCDOSD1	0X4A000014	R/W	LCD OSD Control Register	0x00000000
LCDOSD2	0X4A000018	R/W	Foreground image(OSD Image) Left top position set	0x00000000
LCDOSD3	0X4A00001C	R/W	Foreground image(OSD Image) Right Bottom position set	0x00000000
LCDSADDRB1	0X4A000020	R/W	Frame Buffer Start Address 1(Background buffer 1)	0x00000000
LCDSADDRB2	0X4A000024	R/W	Frame Buffer Start Address 2(Background buffer 2)	0x00000000
LCDSADDRF1	0X4A000028	R/W	Frame Buffer Start Address 1(Foreground buffer 1)	0x00000000
LCDSADDRF2	0X4A00002C	R/W	Frame Buffer Start Address 2(Foreground buffer 2)	0x00000000
LCDEADDRB1	0X4A000030	R/W	Frame Buffer End Address 1(Background buffer 1)	0x00000000
LCDEADDRB2	0X4A000034	R/W	Frame Buffer End Address 2(Background buffer 2)	0x00000000
LCDEADDRF1	0X4A000038	R/W	Frame Buffer End Address 1(Foreground buffer 1)	0x00000000
LCDEADDRF2	0X4A00003C	R/W	Frame Buffer End Address 2(Foreground buffer 2)	0x00000000
LCDVSCRB1	0X4A000040	R/W	Virtual Screen OFFSIZE and PAGEWIDTH(Background buffer 1)	0x00000000
LCDVSCRB2	0X4A000044	R/W	Virtual Screen OFFSIZE and PAGEWIDTH (Background buffer 2)	0x00000000
LCDVSCRF1	0X4A000048	R/W	Virtual Screen OFFSIZE and PAGEWIDTH (Foreground buffer 1)	0x00000000
LCDVSCRF2	0X4A00004C	R/W	Virtual Screen OFFSIZE and PAGEWIDTH (Foreground buffer 2)	0x00000000
LCDINTCON	0X4A000050	R/W	LCD Interrupt Control	0x00000000
LCDKEYCON	0X4A000054	R/W	COLOR KEY Control 1	0x00000000
LCDKEYVAL	0X4A000058	R/W	COLOR KEY Control 2	0x00000000
LCDBGCON	0x4A00005C	R/W	Background color Control	0x00000000
LCDFGCON	0x4A000060	R/W	Foreground color Control	0x00000000
LCDDITHCON	0X4A000064	R/W	LCD Dithering Control for Active Matrix	0x00000000



## LCD CONTROL 1 REGISTER (CONTINUED)

LCDCON1	Bit	Description	Initial State
BPPMODEB	[5:2]	Select the BPP (Bits Per Pixel) mode for background image. 0000 = 1 BPP 0001 = 2 BPP 0010 = 4 BPP 0011 = 8 BPP (palettized) 0100 = 8 BPP (non-palettized, R:3-G:3-B:2) 0101 = 16 BPP (non-palettized, R:5-G:6-B:5) 0110 = 16 BPP (non-palettized, R:5-G:5-B:5-I:1) 0111 = Unpacked 18 BPP (non-palettized) 1xxx = Reserved	0
ENVID	[1]	LCD video output and the logic immediately enable/disable. 0 = Disable the video output and the LCD control signal. 1 = Enable the video output and the LCD control signal.	0
ENVID_F	[0]	LCD video output and the logic enable/disable at current frame end. 0 = Disable the video output and the LCD control signal. 1 = Enable the video output and the LCD control signal. <b>Note:</b> If you on and off this bit, then you will read "H" and video controller is enabled until the end of current frame.	0

**NOTE:** Per Frame video on-off : ENVID & ENVID\_F on-off simultaneously.  
Direct video on-off : ENVID on-off only. (where, ENVID\_F = 0)



## LCD CONTROL 2 REGISTER

Register	Address	R/W	Description	Reset Value
LCDCON2	0X4A000004	R/W	LCD control 2 register	0x00000000

LCDCON2	Bit	Description	Initial state
LINECNT (read only)	[25:15]	Provide the status of the line counter (read only) Up count from 0 to LINEVAL	0
VSTATUS	[14:13]	Vertical Status (read only). 00 = VSYNC                      01 = BACK Porch 10 = ACTIVE                     11 = FRONT Porch	0
HSTATUS	[12:11]	Horizontal Status (read only). 00 = HSYNC                     01 = BACK Porch 10 = ACTIVE                     11 = FRONT Porch	0
PALFRM	[10:9]	This bit determines the size of the palette data format 00 = Reserved                    01 = 18-bit ( 6:6:6) 10 = 16-bit (5:6:5)               11 = 16-bit ( 5:5:5:1)	0
Reserved	[8]	This bit must be "0".	0
IVCLK	[7]	This bit controls the polarity of the VCLK active edge. 0 = The video data is fetched at VCLK falling edge 1 = The video data is fetched at VCLK rising edge	0
IHSYNC	[6]	This bit indicates the HSYNC pulse polarity. 0 = Normal                      1 = Inverted	0
IVSYNC	[5]	This bit indicates the VSYNC pulse polarity. 0 = Normal                      1 = Inverted	0
Reserved	[4]	Reserved	0
IVDEN	[3]	This bit indicates the VDEN signal polarity. 0 = Normal                      1 = Inverted	0
BITSWP	[2]	Bit swap control bit. 0 = Swap Disable               1 = Swap Enable	0
BYTSWP	[1]	Byte swap control bit. 0 = Swap Disable               1 = Swap Enable	0
HAWSWP	[0]	Half-Word swap control bit. 0 = Swap Disable               1 = Swap Enable	0



## LCD TIME CONTROL 1 REGISTER

Register	Address	R/W	Description	Reset Value
LCDTCON1	0X4A000008	R/W	LCD control 2 register	0x00000000

LCDTCON1	Bit	Description	Initial State
VBPD	[23:16]	Vertical back porch is the number of inactive lines at the start of a frame, after vertical synchronization period.	0
VFPD	[15:8]	Vertical front porch is the number of inactive lines at the end of a frame, before vertical synchronization period.	0
VSPW	[7:0]	Vertical sync pulse width determines the VSYNC pulse's sync level width by counting the number of inactive lines.	0

## LCD TIME CONTROL 2 REGISTER

Register	Address	R/W	Description	Reset Value
LCDTCON2	0X4A00000C	R/W	LCD time control 2 register	0x00000000

LCDTCON2	Bit	Description	Initial state
HBPD	[23:16]	Horizontal back porch is the number of VCLK periods between the falling edge of HSYNC and the start of active data.	0000000
HFPD	[15:8]	Horizontal front porch is the number of VCLK periods between the end of active data and the rising edge of HSYNC.	0X00
HSPW	[7:0]	Horizontal sync pulse width determines the HSYNC pulse's sync level width by counting the number of the VCLK.	0X00

## LCD TIME CONTROL 3 REGISTER

Register	Address	R/W	Description	Reset Value
LCDTCON3	0X4A000010	R/W	LCD time control 3 register	0x00000000

LCDTCON3	Bit	Description	Initial state
LINEVAL	[21:11]	These bits determine the vertical size of LCD panel.	0
HOZVAL	[10:0]	These bits determine the horizontal size of LCD panel.	0

## LCD OSD CONTROL 1 REGISTER

Register	Address	R/W	Description	Reset Value
LCDOSD1	0X4A000014	R/W	LCD OSD control 1 register	0x00000000

LCDOSD1	Bit	Description	Initial state
OSDEN_F	[9]	OSD(On-screen display) control bit. 0 = OSD Disable      1 = OSD Enable	0
OSD_BLD_PIX	[8]	Select blending mode 0 = Per plane blending (8/16/18 BPP mode) 1 = Per pixel blending (18 BPP only)	0
OSD_ALPHA	[7:0]	8-bit Alpha value for Per plane defined by Equation 28-1.	0

**NOTE:** OSD\_ALPHA when blending mode is Per pixel should be written in MSB 8 bits of D[31:0].  
If color key is enabled, blending function is not performed.

## LCD OSD CONTROL 2 REGISTER

Register	Address	R/W	Description	Reset Value
LCDOSD2	0X4A000018	R/W	LCD OSD control 2 register	0x0

LCDOSD2	Bit	Description	initial state
OSD_LEFTTOP_X	[21:11]	Horizontal screen coordinate for left top pixel of OSD image	0
OSD_LEFTTOP_Y	[10:0]	Vertical screen coordinate for left top pixel of OSD image	0

## LCD OSD CONTROL 3 REGISTER

Register	Address	R/W	Description	Reset Value
LCDOSD3	0X4A00001C	R/W	LCD OSD control 3 register	0x0

LCDOSD3	Bit	Description	initial state
OSD_RIGHTBOT_X	[21:11]	Horizontal screen coordinate for right bottom pixel of OSD image. OSD_RIGHTBOT_X <= LCD Panel size of X.	0
OSD_RIGHTBOT_Y	[10:0]	Vertical screen coordinate for right bottom pixel of OSD image. OSD_RIGHTBOT_X <= LCD Panel size of Y.	0

**NOTE:** Horizontal screen coordinate of LCDOSD2 and LCDOSD3 must be in word boundary.  
So, 18 BPP mode can has X position by 1 pixel. ( ex, X = 0,1,2,3....)  
16 BPP mode can has X position by 2 pixel. ( ex, X = 0,2,4,6....)  
8 BPP mode can has X position by 4 pixel. ( ex, X = 0,4,8,12....)



## FRAME BUFFER START ADDRESS REGISTERS

Register	Address	R/W	Description	Reset Value
LCDSADDRB1	0X4A000020	R/W	Frame buffer start address register for Background buffer 1	0x0
LCDSADDRB2	0X4A000024	R/W	Frame buffer start address register for Background buffer 2	0x0
LCDSADDRF1	0X4A000028	R/W	Frame buffer start address register for Foreground(OSD) buffer 1	0x0
LCDSADDRF2	0X4A00002C	R/W	Frame buffer start address register for Foreground(OSD) buffer 2	0x0

LCDSADDRxx	Bit	Description	Initial State
LCDBANK	[31:24]	These bits indicate A[31:24] of the bank location for the video buffer in the system memory.	0
LCDBASEU	[23:0]	These bits indicate A[23:0] of the start address of the LCD frame buffer.	0

## FRAME BUFFER END ADDRESS REGISTERS

Register	Address	R/W	Description	Reset Value
LCDEADDRB1	0X4A000030	R/W	Frame buffer end address register for Background buffer 1	0x0
LCDEADDRB2	0X4A000034	R/W	Frame buffer end address register for Background buffer 2	0x0
LCDEADDRF1	0X4A000038	R/W	Frame buffer end address register for Foreground(OSD) buffer 1	0x0
LCDEADDRF2	0X4A00003C	R/W	Frame buffer end address register for Foreground(OSD) buffer 2	0x0

LCDEADDRxx	Bit	Description	Initial State
LCDBASEL	[23:0]	These bits indicate A[23:0] of the end address of the LCD frame buffer. $LCDBASEL = LCDBASEU + (PAGEWIDTH+OFFSIZE) \times (LINEVAL+1)$	0x0000

## VIRTUAL SCREEN OFFSIZE AND PAGEWIDTH REGISTERS

Register	Address	R/W	Description	Reset Value
LCDVSCRb1	0X4A000040	R/W	Virtual screen OFFSIZE and PAGEWIDTH for Background buffer 1	0x00000000
LCDVSCRb2	0X4A000044	R/W	Virtual screen OFFSIZE and PAGEWIDTH for Background buffer 2	0x00000000
LCDVSCRf1	0X4A000048	R/W	Virtual screen OFFSIZE and PAGEWIDTH for Foreground(OSD) buffer 1	0x00000000
LCDVSCRf2	0X4A00004C	R/W	Virtual screen OFFSIZE and PAGEWIDTH for Foreground(OSD) buffer 2	0x00000000

LCDVSCRxx	Bit	Description	Initial State
OFFSIZE	[25:13]	Virtual screen offset size (the number of byte). This value defines the difference between the address of the last byte displayed on the previous LCD line and the address of the first byte to be displayed in the new LCD line. OFFSIZE must has value more than burst length value or 0.	0
PAGEWIDTH	[12:0]	Virtual screen page width (the number of byte). This value defines the width of the view port in the frame. PAGEWIDTH must has value which is multiple of the burst length.	0

## LCD INTERRUPT CONTROL REGISTER

Register	Address	R/W	Description	Reset Value
LCDINTCON	0X4A000050	R/W	Indicate the LCD interrupt control register	0x0

LCDINTCON	Bit	Description	Initial state
FRAMESEL0	[11:10]	LCD Frame Interrupt 2 at start of: 00 = BACK Porch                      01 = VSYNC 10 = ACTIVE                            11 = FRONT Porch	0
FRAMESEL1	[9:8]	LCD Frame Interrupt 1 at start of: 00 = None                                01 = BACK Porch 10 = VSYNC                              11 = FRONT Porch	0
INTFRMEN	[7]	LCD Frame interrupt Enable control bit. 0 = LCD Frame Interrupt Disable 1 = LCD Frame Interrupt Enable	0
Reserved	[6:5]	Reserved.	0
Reserved	[4:2]	Reserved.	0
Reserved	[1]	Reserved.	0
INTEN	[0]	LCD interrupt Enable control bit. 0 = LCD Interrupt Disable 1 = LCD Interrupt Enable	0



## COLOR KEY 1 REGISTER

Register	Address	R/W	Description	Reset Value
LCDKEYCON	0X4A000054	R/W	Color key control register	0x00000

LCDKEYCON	Bit	Description	Initial state
KEYEN	[25]	Color Key (Chroma key ) Enable control 0 = Color key disable, blending enable 1 = Color key enable, blending disable	0
DIRCON	[24]	Color key (Chroma key)direction control 0 = If the pixel value match foreground image with COLVAL according to COMPKEY, pixel from background image is displayed (only in OSD area) 1 = If the pixel value match background with COLVAL according to COMPKEY, pixel from foreground image is displayed (only in OSD area)	0
COMPKEY	[23:0]	Each bit is correspond to the COLVAL[23:0]. If some bit position is set then that bit position of COLVAL and pixel value will not be compared.	0

## COLOR KEY 2 REGISTER

Register	Address	R/W	Description	Reset Value
LDCDCOLVAL	0X4A000058	R/W	Color key value ( transparent value) register	0x00000000

LDCDCOLVAL	Bit	Description	Initial state
COLVAL	[23:0]	Color key value for the transparent pixel effect.	0

**NOTE:** COLVAL and COMPKEY use 24-bit data at all BPP mode.

18 BPP mode: 18-bit color value is valid.

COLVAL	23	22	21	20	19	18	17-16	15	14	13	12	11	10	9-8	7	6	5	4	3	2	1-0
Data	R5	R4	R3	R2	R1	R0	x	G5	G4	G3	G2	G1	G0	x	B5	B4	B3	B2	B1	B0	x

x: Don't care, We recommend that those bits are filled with '0'.

COMPKEY	23	22	21	20	19	18	17-16	15	14	13	12	11	10	9-8	7	6	5	4	3	2	1-0
Data	R5	R4	R3	R2	R1	R0	0x3	G5	G4	G3	G2	G1	G0	0x3	B5	B4	B3	B2	B1	B0	0x3

COMPKEY[17:16], COMPKEY[9: 8] and COMPKEY[1:0] must be 0x3.

16 BPP (5:6:5) mode: 16 bit color value is valid

COLVAL	23	22	21	20	19	18-16	15	14	13	12	11	10	9-8	7	6	5	4	3	2-0
Data	R5	R4	R3	R2	R1	x	G5	G4	G3	G2	G1	G0	x	B5	B4	B3	B2	B1	x

x: Don't care, We recommend that those bits are filled with '0'.

COMPKEY Y	23	22	21	20	19	18-16	15	14	13	12	11	10	9-8	7	6	5	4	3	2-0
Data	R5	R4	R3	R2	R1	0x7	G5	G4	G3	G2	G1	G0	0x3	B5	B4	B3	B2	B1	0x7

COMPKEY[18:16] and COMPKEY[2:0] must be 0x7.

COMPKEY[9:8] must be 0x3.

COMPKEY register must be set properly for the each BPP mode.

#### BACKGROUND COLOR MAP

Register	Address	R/W	Description	Reset Value
LCDBGCON	0X4A00005C	R/W	Background color control	0x00000

LCDBGCON	Bit	Description	Initial state
BGCOLEN	[24]	Background color mapping control bit. If this bit is enabled then LCD background DMA will stop, and GBCOLOR will be appear on background image instead of original image. 0 = Disable 1 = Enable	0
BGCOLOR	[23:0]	Color value	0

## FOREGROUND COLOR MAP

Register	Address	R/W	Description	Reset Value
LCDFGCON	0X4A000060	R/W	Foreground color control	0x00000

LCDFGCON	Bit	Description	Initial state
FGCOLEN	[24]	Foreground color mapping control bit . If this bit is enabled then lcd foreground DMA will stop, and FGCOLOR will be appear on foreground image instead of original image. 0 = Disable 1 = Enable	0
FGCOLOR	[23:0]	Color Value	0

## DITHERING CONTROL 1 REGISTER

Register	Address	R/W	Description	Reset Value
LCDDITHMODE	0X4A000064	R/W	Dithering mode register.	0x00000

LCDDITHMODE	Bit	Description	Initial state
RDithPos	[6:5]	Red Dither bit control 01 = 6-bit 1x = 5-bit	0
GDithPos	[4:3]	Green Dither bit control 01 = 6-bit 1x = 5-bit	0
BDithPos	[2:1]	Blue Dither bit control 01 = 6-bit 1x = 5-bit	0
DITHEN	[0]	Dithering Enable bit 0 = Dithering disable 1 = Dithering enable	0

## NOTES:

- Dithering function can reduce the "contouring" effect.  
The "contouring" effect is a undesirable artifact which can be occurred at the following cases.
  - Reduce quantization ( pre-view of camera image)
  - Conversion of image data from YUV format to an RGB format
  - Edge boosting ( rigid line of 3D image )
  - Etc.
- LCD controller use fixed dithering matrix, and it can occur the side artifact known as "graininess".  
So, user must make decision by trade-off between contouring effect and graininess effect.



**BACKGROUND PALETTE RAM ACCESS ADDRESS (NOT SFR)**

Index	Address	R/W	Description	Reset Value
00	0X4A001000	R/W	Background palette entry 0 address	undefined
01	0X4A001004	R/W	Background palette entry 1 address	undefined
–	–	–	–	–
FF	0x4A0013FC	R/W	Background palette entry 255 address	undefined

**FOREGROUND PALETTE RAM ACCESS ADDRESS (NOT SFR)**

Index	Address	R/W	Description	Reset Value
00	0X4A002000	R/W	Foreground palette entry 0 address	undefined
01	0X4A002004	R/W	Foreground palette entry 1 address	undefined
–	–	–	–	–
FF	0x4A0023FC	R/W	Foreground palette entry 255 address	undefined

## NOTES

# 29 KEY PAD I/F

## OVERVIEW

The Key Pad I/F in S3C24A0A receive the key matrix inputs. An internal register remembers the last key pressed even after the key is released. It provides interrupt source and status register at the moment of key pressed or key released or both cases. The internal debouncing filter prevents the switching noises.

The **KEYDAT** register value is the number of the pressed key. The number of 25 key is same as Figure 29-1.

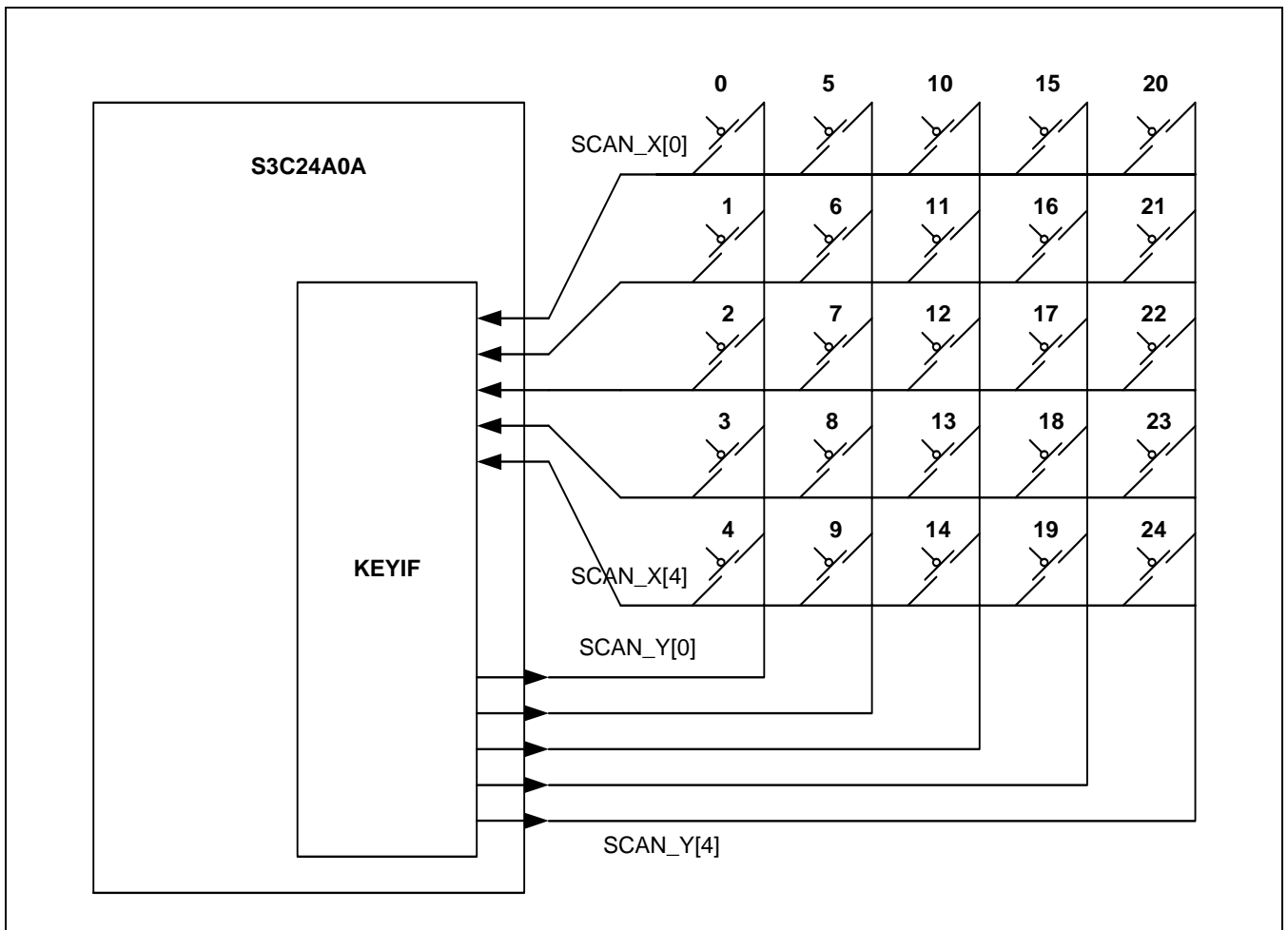

Figure 29-1. Key Matrix Interface Guide

**KEYPAD CONTROL REGISTER****KEYPAD CONTROL REGISTERS (KEYDAT, KEYPUP)**

Register	Address	R/W	Description	Reset Value
KEYDAT	0x44900000	R/W	The data register for KEYPAD input	0x20

KEYDAT	Bit	Description
KEYDAT[3:0]	[4:0]	KEYPAD input decoding data (Read Only)
KEYVAL	[5]	KEYDAT Valid Status (Read Only) 0 = Valid                      1 = Invalid
KEYCLEAR	[6]	Key Clear (Write Only) 0 = No action                1 = Clear the KEYDAT
KEYEN	[7]	KEY Enable 0 = Disable                 1 = Enable

**KEYPAD INTERRUPT CONTROL REGISTER**

Register	Address	R/W	Description	Reset Value
KEYINTC	0x44900004	R/W	KEYPAD input ports interrupt control	0x0

KEYINTC	Bit	Description
KEYINTLV	[2:0]	KEYPAD input ports interrupt level 000 = Low level (Key Pressing)      001 = High level(Key Not Pressing) 010 = Rising edge(Key Released)    10x = Falling edge (Key Pressed) 11x = Both edge(Key Released or Key Pressed)
KEYINTEN	[3]	Interrupt enable of KEYPAD input ports. 0 = Disable                1 = Enable

**DEBOUNCING FILTER**

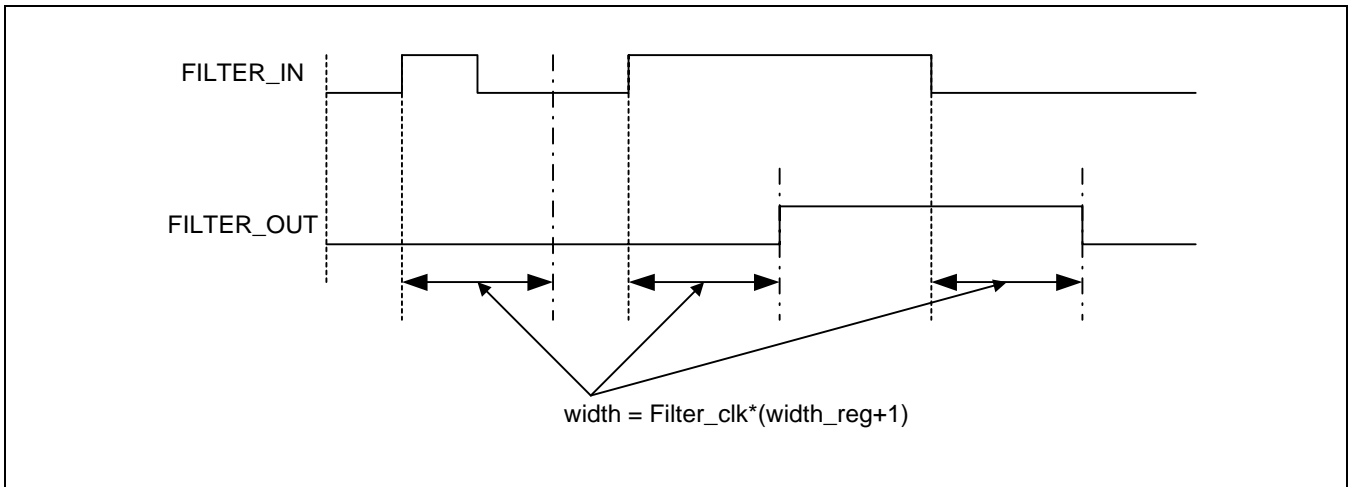

**KEYPAD FILTER CONTROL REGISTER ( KEYFLT )**

Register	Address	R/W	Description	Reset Value
KEYFLT0	0x44900008	R/W	KEY PAD input filter control register	0x0000
KEYFLT1	0x4490000C	R/W	KEY PAD input filter control register	0x0000

KEYFLT0	Bit	Description
SELCLK	[0]	Select Filter Clock 0 = RTC Clock                      1 = GCLK
FILEN	[1]	Filter Enable 0 = Disable                              1 = Enable
Reserved	[15:2]	Must be "0"

KEYFLT1	Bit	Description
WIDTH_reg	[13:0]	Filtering width of KEYPAD input ports.
Reserved	[15:14]	Must be "0"



## KEYPAD MANUAL SCAN CONTROL REGISTER (YMAN)

Register	Address	R/W	Description	Reset Value
KEYMAN	0x44900010	R/W	KEYPAD manual scan control	0x1F

YMAN	Bit	Description
Y_VAL	[4:0]	KEYPAD manual column value.(Read) KEYPAD manual row value.(Write)
MAN_EN	[5]	KEYPAD manual scan control enable 0 = Disable    1= Enable

# 30

## ADC & TOUCH SCREEN INTERFACE

### OVERVIEW

The 10-bit CMOS ADC (Analog to Digital Converter) of S3C24A0A is a recycling type device with 8-channel analog inputs. It converts the analog input signal into 10-bit binary digital codes at a maximum conversion rate of 500KSPS with 2.5MHz A/D converter clock. A/D converter operates with on-chip sample-and-hold function and power down mode is supported.

S3C24A0A supports Touch Screen Interface. This function consists of touch screen panel, 4 internal switch, external voltage source, AIN[7] and AIN[5] (refer to the example, Figure 30-2). Touch Screen Interface is controlling and selecting control signal (nYPON, YMON, nXPON and XMON) and analog pads (AIN[7] and AIN[5]) which are connected with pads of touch screen panel and the internal switch for X-position conversion and Y-position conversion. Touch Screen Interface contains switch control logic and ADC interface logic with interrupt generation logic.

### FEATURES

- Resolution: 10-bit
- Differential Linearity Error:  $\pm 1.0$  LSB
- Integral Linearity Error :  $\pm 2.0$  LSB
- Maximum Conversion Rate: 500 KSPS
- Low Power Consumption
- Internal switch for X-position conversion and Y-position conversion
- Power Supply Voltage: 3.3V
- Analog Input Range: 0 ~ 3.3V
- On-chip sample-and-hold function
- Normal Conversion Mode
- Separate X/Y position conversion Mode
- Auto (Sequential) X/Y Position Conversion Mode
- Waiting for Interrupt Mode (Stylus pen up or down interrupt)

## ADC & TOUCH SCREEN INTERFACE OPERATION

### BLOCK DIAGRAM

Figure 30-1 shows the functional block diagram of S3C24A0A A/D converter and Touch Screen Interface. Note that the A/D converter device is a recycling type.

A pull-up resistor is attached to AIN[7] on VDDA\_ADC. So, XP pad of touch screen panel should be connected with AIN[7] of S3C24A0A and YP pad of touch screen panel should be connected with AIN[5].

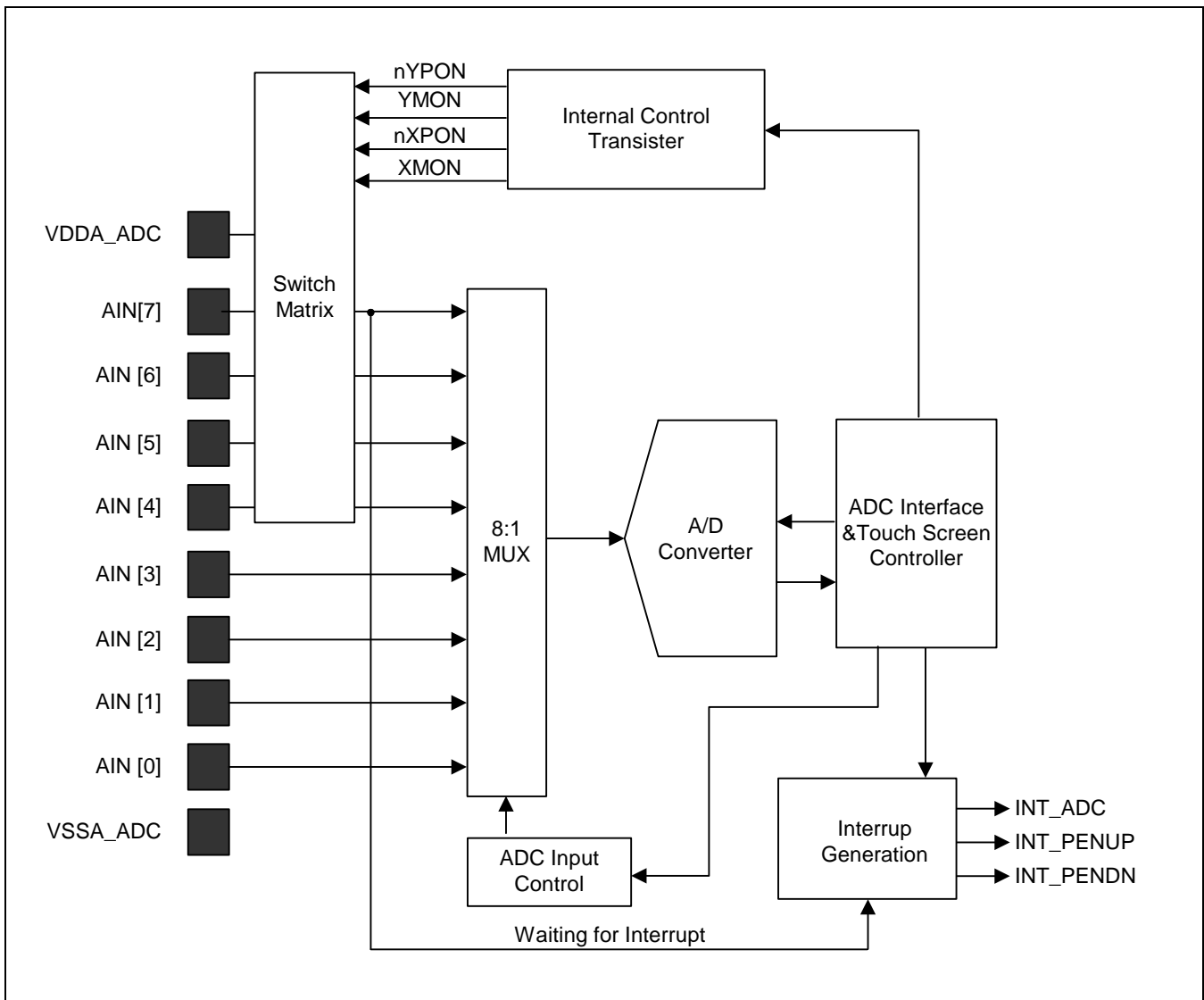
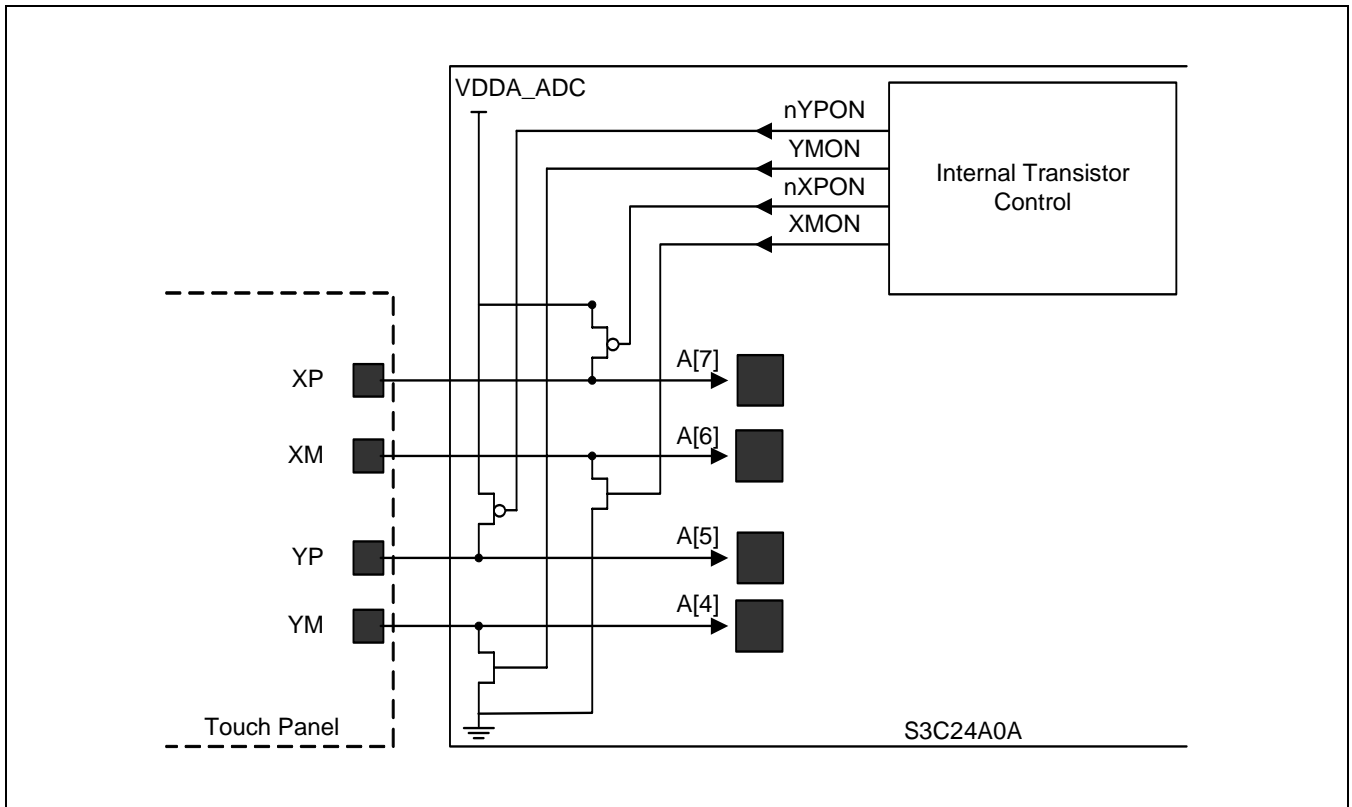

Figure 30-1. ADC and Touch Screen Interface Functional Block Diagram



**EXAMPLE FOR TOUCH SCREEN**

In this example, AIN[7] is connected with XP and AIN[5] is connected with YP pad of touch screen panel. To control pads of touch screen panel (XP, XM, YP and YM), 4 internal transistor are applied and control signals, nYPON, YMON, nXPON and XMON are connected with 4 internal transistor.



**Figure 30-2. Example of ADC and Touch Screen Interface**

1. Select Separate X/Y Position Conversion Mode or Auto (Sequential) X/Y Position Conversion Mode to get X/Y position.
2. Set Touch Screen Interface to Waiting Interrupt Mode,
3. If interrupt occurs, then appropriate conversion (Separate X/Y Position Conversion Mode or Auto (Sequential) X/Y Position Conversion Mode) is activated.
4. After get the proper value about X/Y position, return to Waiting for Interrupt Mode.

## FUNCTION DESCRIPTIONS

### A/D Conversion Time

When the PCLK frequency is 50 MHz and the prescaler value is 49, total 10-bit conversion time is as follows.

$$A/D \text{ converter freq.} = 50 \text{ MHz} / (49 + 1) = 1 \text{ MHz}$$

$$\text{Conversion time} = 1 / (1 \text{ MHz} / 5 \text{ cycles}) = 1 / 200 \text{ kHz} = 5 \text{ us}$$

### NOTE

This A/D converter was designed to operate at maximum 2.5MHz clock, so the conversion rate can go up to 500 KSPS.

### Touch Screen Interface Mode

#### 1. Normal Conversion Mode

Normal Conversion Mode (AUTO\_PST = 0, XY\_PST = 0) is the most likely used for General Purpose ADC Conversion. This mode can be initialized by setting the ADCCON and ADCTSC and completed with a read the XPDATA (Normal ADC) value of ADCDAX (ADC Data Register 0).

#### 2. Separate X/Y Position Conversion Mode

Touch Screen Controller can be operated by one of two Conversion Modes. Separate X/Y Position Conversion Mode is operated as the following way;

X-Position Mode (AUTO\_PST = 0 and XY\_PST = 1) writes X-Position Conversion Data to XPDATA of ADCDAX register, After conversion, Touch Screen Interface generates the Interrupt source (INT\_ADC) to Interrupt Controller.

Y-Position Mode (AUTO\_PST = 0 and XY\_PST = 2) writes Y-Position Conversion Data to YPDATA of ADCDAY, After conversion, Touch Screen Interface generates the Interrupt source (INT\_ADC) to Interrupt Controller also.

**Table 30-1. Condition of Touch Screen Panel Pads in Separate X/Y Position Conversion Mode**

	XP	XM	YP	YM
X Position Conversion	VDDA_ADC	GND	AIN[5]	Hi-Z
Y Position Conversion	AIN[7]	Hi-Z	VDDA_ADC	GND

## 1. Auto(Sequential) X/Y Position Conversion Mode

Auto (Sequential) X/Y Position Conversion Mode (AUTO\_PST = 1 and XY\_PST = 0) is operated as the following;

Touch Screen Controller automatically converts X-Position and Y-Position. Touch Screen Controller writes X-measurement data to XPDATA of ADCDAX, and then writes Y-measurement data to YPDATA of ADCDAY. After Auto (Sequential) Position Conversion, Touch Screen Controller is generating Interrupt source(INT\_ADC) to Interrupt Controller.

**Table 30-2. Condition of Touch Screen Panel Pads in Auto (Sequential) X/Y Position Conversion Mode**

	XP	XM	YP	YM
X Position Conversion	VDDA_ADC	GND	AIN[5]	Hi-Z
Y Position Conversion	AIN[7]	Hi-Z	VDDA_ADC	GND

## 2. Waiting for Interrupt Mode

When Touch Screen Controller is in Waiting for Interrupt Mode (YM\_SEN = 1, XP\_SEN = 1 and XY\_PST = 3), Touch Screen Controller is waiting for Stylus down or up. Touch Screen Controller is generating Interrupt (INT\_PENDN or INT\_PENUP) signal when the Stylus is down or up on Touch Screen Panel.

After interrupt occurs, X and Y position can be read by the proper conversion mode (Separate X/Y position conversion Mode or Auto X/Y Position Conversion Mode).

**Table 30-3. Condition of Touch Screen Panel Pads in Waiting for Interrupt Mode**

	XP	XM	YP	YM
Waiting for Interrupt Mode	AIN[7](Pull-up enable)	Hi-Z	AIN[5]	GND

## Standby Mode

Standby mode is activated when STDBM of ADCCON register is set to '1'. In this mode, A/D conversion operation is halted and XPDATA (Normal ADC) of ADCDAX and YPDATA of ADCDAY contain the previous converted data.

### Programming Notes

1. The A/D converted data can be accessed by means of interrupt or polling method. With interrupt method the overall conversion time - from A/D converter start to converted data read - may be delayed because of the return time of interrupt service routine and data access time. With polling method, by checking the ADCCON[15] - end of conversion flag-bit, the read time from ADCDAT register can be determined.
2. Another way for starting A/D conversion is provided. After ADCCON[1] - A/D conversion start-by-read mode-is set to 1, A/D conversion starts simultaneously whenever converted data is read.

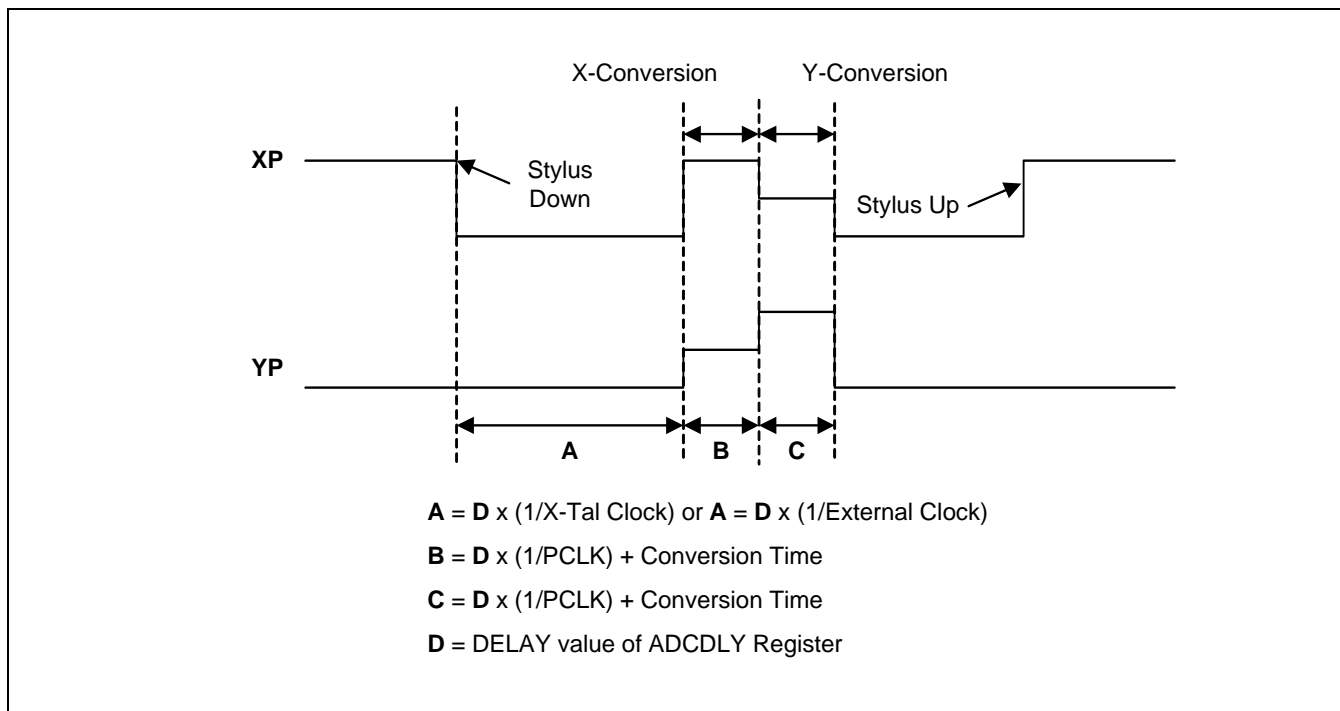

Figure 30-3. Timing Diagram at Auto (Sequential) X/Y Position Conversion Mode

## ADC AND TOUCH SCREEN INTERFACE SPECIAL REGISTERS

### ADC CONTROL REGISTER (ADCCON)

Register	Address	R/W	Description	Reset Value
ADCCON	0x4580_0000	R/W	ADC control register	0x3FC4

ADCCON	Bit	Description	Initial State
ECFLG	[15]	End of conversion flag(Read only) 0 = A/D conversion in process 1 = End of A/D conversion	0
PRSCEN	[14]	A/D converter prescaler enable 0 = Disable 1 = Enable	0
PRSCVL	[13:6]	A/D converter prescaler value Data value: 1 ~ 255 <b>Note:</b> ADC Frequency should be set less than PCLK by 5times. (Ex. PCLK=10MHZ, ADC Freq.< 2MHz)	0xFF
SEL_MUX	[5:3]	Analog input channel select 000 = AIN 0 001 = AIN 1 010 = AIN 2 011 = AIN 3 100 = AIN 4 101 = AIN 5 (YP) 110 = AIN 6 111 = AIN 7 (XP)	0
STDBM	[2]	Standby mode select 0 = Normal operation mode 1 = Standby mode	1
READ_START	[1]	A/D conversion start by read 0 = Disable start by read operation 1 = Enable start by read operation	0
ENABLE_START	[0]	A/D conversion starts by setting this bit. If READ_START is enabled, this value is not valid. 0 = No operation 1 = A/D conversion starts and this bit is cleared after the start-up.	0

## ADC TOUCH SCREEN CONTROL REGISTER (ADCTSC)

Register	Address	R/W	Description	Reset Value
ADCTSC	0x4580_0004	R/W	ADC touch screen control register	0x058

ADCTSC	Bit	Description	Initial State
Reserved	[11:8]	Reserved. Should be set to 0.	0
YM_SEN	[7]	Select output value of YMON 0 = YMON output is 0. (YM = Hi-Z) 1 = YMON output is 1. (YM = GND)	0
YP_SEN	[6]	Select output value of nYPON 0 = nYPON output is 0. (YP = External voltage) 1 = nYPON output is 1. (YP is connected with AIN[5])	1
XM_SEN	[5]	Select output value of XMON 0 = XMON output is 0. (XM = Hi-Z) 1 = XMON output is 1. (XM = GND)	0
XP_SEN	[4]	Select output value of nXPON 0 = nXPON output is 0. (XP = External voltage) 1 = nXPON output is 1. (XP is connected with AIN[7])	1
PULL_UP <sup>(1)</sup>	[3]	Pull-up Switch Enable 0 = XP Pull-up Enable. 1 = XP Pull-up Disable.	1
AUTO_PST <sup>(2)</sup>	[2]	Automatically sequencing conversion of X-Position and Y-Position 0 = Normal ADC conversion. 1 = Auto (Sequential) X/Y Position Conversion Mode.	0
XY_PST <sup>(3)</sup>	[1:0]	Manually measurement of X-Position or Y-Position. 00 = No operation mode 01 = X-position measurement 10 = Y-position measurement 11 = Waiting for Interrupt Mode	0

## NOTES:

1. Unexpected pen-up or pen-down interrupt may be occurred when pull-up switch is turn on. It is recommended that pull-up enable switch is turn on before setting to the waiting for interrupt mode because some stabilization time of pull-up switch is needed.
2. AUTO\_PST bit should be set whenever the data conversion ends if the conversion start by read mode is activated.
3. When all data conversions are finished at automatically sequencing conversion mode, the conversion pointer remained at Y position conversion mode. It is recommended to set XY\_PST register to "01" (X-position measurement mode) every conversion time for getting right result.

**ADC START DELAY REGISTER (ADCDLY)**

Register	Address	R/W	Description	Reset Value
ADCDLY	0x4580_0008	R/W	ADC start or interval delay register	0x00ff

ADCDLY	Bit	Description	Initial State
DELAY	[15:0]	Normal Conversion Mode, Separate X/Y Position Conversion Mode, Auto (Sequential) X/Y Position Conversion Mode. → X/Y Position Conversion Delay Value. Waiting for Interrupt Mode. When Stylus down occurs at Waiting for Interrupt Mode, generates Interrupt signal (INT_ADC), having interval (several ms), for Auto X/Y Position conversion. <b>Note:</b> Don't use Zero value(0x0000)	00ff

**NOTES:**

1. Before ADC conversion, Touch screen uses X-tal clock or EXTCLK (Waiting for Interrupt Mode).
2. During ADC conversion PCLK is used.

**ADC CONVERSION DATA REGISTER (ADC DAX)**

Register	Address	R/W	Description	Reset Value
ADC DAX	0x4580_000C	R	ADC conversion data register X-Position conversion data at Touch Screen mode	–

ADC DAX	Bit	Description	Initial State
UPDOWN	[15]	Up or Down state of Stylus at Waiting for Interrupt Mode. 0 = Stylus down state. 1 = Stylus up state.	–
AUTO_PST	[14]	Automatic sequencing conversion of X-Position and Y-Position 0 = Normal ADC conversion. 1 = Sequencing measurement of X-position, Y-position.	–
XY_PST	[13:12]	Manually measurement of X-Position or Y-Position. 00 = No operation mode 01 = X-position measurement 10 = Y-position measurement 11 = Waiting for Interrupt Mode	–
Reserved	[11:10]	Reserved	–
XPDATA (Normal ADC)	[9:0]	X-Position Conversion data value (include Normal ADC Conversion data value) Data value: 0 ~ 3FF	–



**ADC CONVERSION DATA REGISTER (ADCDAY)**

Register	Address	R/W	Description	Reset Value
ADCDAY	0x4580_0010	R	ADC conversion data register Y-Position conversion data at Touch Screen mode	–

ADCDAY	Bit	Description	Initial State
UPDOWN	[15]	Up or Down state of Stylus at Waiting for Interrupt Mode. 0 = Stylus down state. 1 = Stylus up state.	–
AUTO_PST	[14]	Automatically sequencing conversion of X-Position and Y-Position 0 = Normal ADC conversion. 1 = Sequencing measurement of X-position, Y-position.	–
XY_PST	[13:12]	Manually measurement of X-Position or Y-Position. 00 = No operation mode 01 = X-position measurement 10 = Y-position measurement 11 = Waiting for Interrupt Mode	–
Reserved	[11:10]	Reserved	–
Ypdata	[9:0]	Y-Position Conversion data value Data value: 0 ~ 3FF	–

## NOTES

# 31

## SECURE DIGITAL INTERFACE

### OVERVIEW

The S3C24A0A SDI(Secure Digital Interface) can interface for SD memory card, SDIO device and MMC(Multi-Media Card).

### FEATURE

- SD Memory Card Spec (Ver 1.0) / MMC Spec (2.11) compatible
- SDIO Card Spec (Ver 1.0) compatible
- 16 words(64 bytes) FIFO for data Tx/Rx
- 40-bit Command Register
- 136-bit Response Register
- 8-bit Prescaler logic ( $\text{Freq} = \text{System Clock} / (P + 1)$ )
- Normal, and DMA data transfer mode (byte, halfword, word transfer)
- DMA burst4 access support(only word transfer)
- 1-bit / 4-bit (wide bus) mode & block / stream mode switch support

## BLOCK DIAGRAM

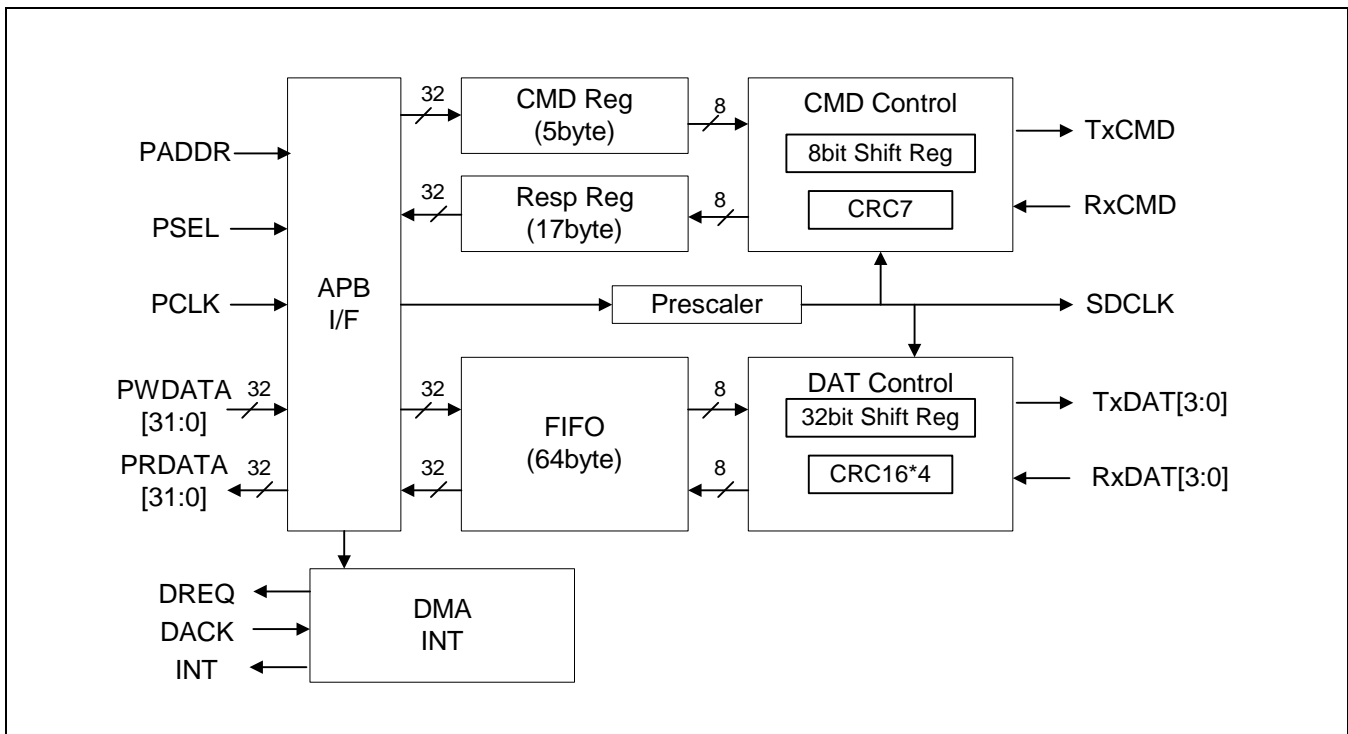

Figure 31-1. SDI Block Diagram

## SDI OPERATION

A serial clock line synchronizes shifting and sampling of the information on the five data lines. The transmission frequency is controlled by making the appropriate bit settings to the SDIPRE register. You can modify its frequency to adjust the baud rate data register value.

### Programming Procedure (common)

To program the SDI modules, follow these basic steps:

1. Set SDICON to configure properly with clock & interrupt enable
2. Set SDIPRE to configure with a proper value.
3. Wait 74 SDCLK clock cycle in order to initialize the card.

### CMD Path Programming

1. Write command argument 32bit to SDICARG.
2. Determine command types and start command transmit with setting SDICCON.
3. Confirm the end of SDI CMD path operation when the specific flag of SDICSTA is set
4. The flag is CmdSent if command type is no response.
5. The flag is RspFin if command type is with response.
6. Clear the corresponding flag of SDICSTA through writing one with this bit

### DAT Path Programming

1. Write data timeout period to SDIDTIMER.
2. Write block size(block length) to SDIBSIZE(normally 0x80 word).
3. Determine the mode of block, wide bus, dma, etc and start data transfer with setting SDIDCON.
4. Tx data → Write data to Data Register(SDIDAT) while Tx FIFO is available(TFDET is set), or half(TFHalf is set), or empty(TFEmpty is set).
5. Rx data → Read data from Data Register(SDIDAT) while Rx FIFO is available(RFDET is set), or full(RFFull is set), or half(RFHalf is set), or ready for last data(RFLast is set).
6. Confirm the end of SDI DAT path operation when DatFin flag of SDIDSTA is set
7. Clear the corresponding flag of SDIDSTA through writing one with this bit



## SDIO OPERATION

There are two functions of SDIO operation: SDIO Interrupt receiving and Read Wait Request generation. These two functions can operate when RcvIOInt bit and RwaitEn bit of SDICON register is activated respectively. And two functions have the steps and conditions like below.

### SDIO Interrupt

In SD 1bit mode, Interrupt is received through all range from RxDAT [1] pin.

In SD 4bit mode, RxDAT[1] pin is shared between data receiving and interrupt receiving. When interrupt detection range (Interrupt Period) is:

1. Single Block : the time between A and B  
A: 2clocks after the completion of a data packet  
B: The completion of sending the end bit of the next with data command
2. Multi Block, PrdType = 0: the time between A and B, restart at C  
A: 2clocks after the completion of a data packet  
B: 2clocks after A  
C: 2clocks after the end bit of the abort command response
3. Multi Block, PrdType = 1: the time between A and B, restart at A  
A: 2clocks after the completion of a data packet  
B: 2clocks after A

In case of last block, interrupt period begins at A, but not ends at B(CMD53 case)

### Read Wait Request

Regardless of 1bit or 4-bit mode, Read Wait Request signal transmits to TxDAT[2] pin in condition of below.

- In read multiple operation, request signal transmission begins at 2clocks after the end of the data block
- Transmission ends when user sets to one RwaitReq bit of SDIDSTA register

## SDI SPECIAL REGISTERS

## SDI CONTROL REGISTER (SDICON)

Register	Address	R/W	Description	Reset Value
SDICON	0x4600_0000	R/W	SDI Control Register	0x0

SDICON	Bit	Description	Initial Value
Reserved	[31:9]	–	
SDMMC Reset (SDreset)	[8]	Reset whole sdmmc block. This bit is automatically clear. 0 = Normal mode, 1 = SDMMC reset	0
Hold Margin (HoldMgn)	[7:6]	Determines how much you delay CMD, DAT lines for hold margin in MMC clock type 00 = 1/2 PCLK cycle, 01 = 1 PCLK cycle 10 = 3/2 PCLK cycles, 11 = 2 PCLK cycles	0
Clock Type (CTYP)	[5]	Determines which clock type is used as SDCLK. 0 = SD type, 1 = MMC type	0
Byte Order Type(ByteOrder)	[4]	Determines byte order type when you read(write) data from(to) sd host FIFO with word boundary. 0 = Type A, 1 = Type B	0
Receive SDIO Interrupt from card (RcvIOInt)	[3]	Determines whether SD host receives SDIO Interrupt from the card or not(for SDIO). 0 = Ignore, 1 = Receive SDIO Interrupt	0
Read Wait Enable(RWaitEn)	[2]	Determines read wait request signal generate when SD host waits the next block in multiple block read mode. This bit needs to delay the next block to be transmitted from the card(for SDIO). 0 = Disable(no generate), 1 = Read wait enable(use SDIO)	0
Reserved	[1]	–	
Clock Out Enable (ENCLK)	[0]	Determines whether SDCLK Out enable or not 0 = Disable(prescaler off), 1 = Clock enable	0

**NOTE:** Byte Order Type

- Type A: (Access by Word) D[7:0] → D[15:8] → D[23:16] → D[31:24]  
(Access by Halfword) D[7:0] → D[15:8]
- Type B: (Access by Word) D[31:24] → D[23:16] → D[15:8] → D[7:0]  
(Access by Halfword) D[15:8] → D[7:0]



**SDI BAUD RATE PRESCALER REGISTER (SDIPRE)**

Register	Address	R/W	Description	Reset Value
SDIPRE	0x4600_0004	R/W	SDI buad rate prescaler register	0x01

SDIPRE	Bit	Description	Initial Value
Prescaler Value	[7:0]	Determines SDI clock (SDCLK) rate as above equation. Baud rate = PCLK / (Prescaler value + 1)	0x01

**NOTE:** Prescaler Value should be greater than zero.

**SDI COMMAND ARGUMENT REGISTER (SDICARG)**

Register	Address	R/W	Description	Reset Value
SDICARG	0x4600_0008	R/W	SDI command argument register	0x0

SDICARG	Bit	Description	Initial Value
CmdArg	[31:0]	Command argument	0x00000000

**SDI COMMAND CONTROL REGISTER (SDICCON)**

Register	Address	R/W	Description	Reset Value
SDICCON	0x4600_000c	R/W	SDI command control register	0x0

SDICCON	Bit	Description	Initial Value
Reserved	[31:13]		
Abort Command (AbortCmd)	[12]	Determines whether command type is for abort (for SDIO). 0 = Normal command, 1 = Abort command (CMD12, CMD52)	0
Command with Data (WithData)	[11]	Determines whether command type is with data (for SDIO). 0 = Without data, 1 = With data	0
LongRsp	[10]	Determines whether host receives a 136-bit long response or not 0 = Short response, 1 = Long response	0
WaitRsp	[9]	Determines whether host waits for a response or not 0 = No response, 1 = Wait response	0
Command Start(CMST)	[8]	Determines whether command operation starts or not. . This bit is automatically clear 0 = Command ready, 1 = Command start	0
CmdIndex	[7:0]	Command index with start 2-bit (8-bit)	0x00



**SDI COMMAND STATUS REGISTER (SDICSTA)**

Register	Address	R/W	Description	Reset Value
SDICSTA	0x4600_0010	R/(C)	SDI command status register	0x0

SDICSTA	Bit	Description	Initial Value
Reserved	[31:13]		
Response CRC Fail(RspCrc)	[12] R/C	CRC check failed when command response received. This flag is cleared by setting to one this bit. 0 = Not detect, 1 = CRC fail	0
Command Sent (CmdSent)	[11] R/C	Command sent(not concerned with response). This flag is cleared by setting to one this bit. 0 = Not detect, 1 = Command end	0
Command Time Out (CmdTout)	[10] R/C	Command response timeout (64CLK). This flag is cleared by setting to one this bit. 0 = Not detect, 1 = Timeout	0
Response Receive End (RspFin)	[9] R/C	Command response received. This flag is cleared by setting to one this bit. 0 = Not detect, 1 = Response end	0
CMD line progress On (CmdOn)	[8]	Command transfer in progress 0 = Not detect, 1 = In progress	0
RspIndex	[7:0]	Response index 6bit with start 2-bit (8-bit)	0x00

**SDI RESPONSE REGISTER0 (SDIRSP0)**

Register	Address	R/W	Description	Reset Value
SDIRSP0	0x4600_0014	R	SDI response register 0	0x0

SDIRSP0	Bit	Description	Initial Value
Response0	[31:0]	Card status[31:0](short), card status[127:96](long)	0x00000000

**SDI RESPONSE REGISTER1 (SDIRSP1)**

Register	Address	R/W	Description	Reset Value
SDIRSP1	0x4600_0018	R	SDI response register 1	0x0

SDIRSP1	Bit	Description	Initial Value
RCRC7	[31:24]	CRC7(with end bit, short), card status[95:88](long)	0x00
Response1	[23:0]	Unused(short), card status[87:64](long)	0x000000



**SDI RESPONSE REGISTER2 (SDIRSP2)**

Register	Address	R/W	Description	Reset Value
SDIRSP2	0x4600_001c	R	SDI response register 2	0x0

SDIRSP2	Bit	Description	Initial Value
Response2	[31:0]	Unused(short), card status[63:32](long)	0x00000000

**SDI RESPONSE REGISTER3 (SDIRSP3)**

Register	Address	R/W	Description	Reset Value
SDIRSP3	0x4600_0020	R	SDI response register 3	0x0

SDIRSP3	Bit	Description	Initial Value
Response3	[31:0]	Unused(short), card status[31:0](long)	0x00000000

**SDI DATA / BUSY TIMER REGISTER (SDIDTIMER)**

Register	Address	R/W	Description	Reset Value
SDIDTIMER	0x4600_0024	R/W	SDI data / busy timer register	0x0

SDIDTIMER	Bit	Description	Initial Value
Reserved	[31:21]	–	–
DataTimer	[22:0]	Data / Busy timeout period(0~2M cycle)	0x10000

**SDI BLOCK SIZE REGISTER (SDIBSIZE)**

Register	Address	R/W	Description	Reset Value
SDIBSIZE	0x4600_0028	R/W	SDI block size register	0x0

SDIBSIZE	Bit	Description	Initial Value
Reserved	[31:12]	–	–
BlkSize	[11:0]	Block Size value(0 ~ 4095 byte) , don't care when stream mode	0x000

**NOTE:** In Case of multi block, BlkSize must be aligned to word (4byte) size. (BlkSize[1:0] = 00)



**SDI DATA REMAIN COUNTER REGISTER (SDIDCNT)**

Register	Address	R/W	Description	Reset Value
SDIDCNT	0x4600_0030	R	SDI data remain counter register	0x0

SDIDCNT	Bit	Description	Initial Value
Reserved	[31:24]	–	–
BlkNumCnt	[23:12]	Remaining block number	0x000
BlkCnt	[11:0]	Remaining data byte of 1 block	0x000

## SDI DATA STATUS REGISTER (SDIDSTA)

Register	Address	R/W	Description	Reset Value
SDIDSTA	0x4600_0034	R/(C)	SDI data status register	0x0

SDIDSTA	Bit	Description	Initial Value
Reserved	[31:12]	–	–
No Busy(NoBusy)	[11] R/C	Busy is not active during 16cycle after CMD packet transmitted in only busy check mode. This flag is cleared by setting to 1 this bit. 0 = Not detect,                    1 = No busy signal	0
Read Wait Request Occur (RWaitReq)	[10] R/C	Read wait request signal transmits to SD card. The request signal is stopped and this flag is cleared by setting to one this bit. 0 = Not occur,                    1 = Read wait request occur	0
SDIO Interrupt Detect (IOIntDet)	[9] R/C	SDIO interrupt detect. This flag is cleared by setting to one this bit. 0 = Not detect,                    1 = SDIO interrupt detect	0
Reserved	[8]	–	–
CRC Status Fail (CrcSta)	[7] R/C	CRC Status error when data block sent(CRC check failed). This flag is cleared by setting to one this bit. 0 = Not detect,                    1 = CRC status fail	0
Data Receive CRC Fail (DatCrc)	[6] R/C	Data block received error(CRC check failed). This flag is cleared by setting to one this bit. 0 = Not detect,                    1 = Receive CRC fail	0
Data Time Out (DatTout)	[5] R/C	Data / Busy receive timeout. This flag is cleared by setting to one this bit. 0 = Not detect,                    1 = Timeout	0
Data Transfer Finish (DatFin)	[4] R/C	Data transfer completes (data counter is zero). This flag is cleared by setting to one this bit. 0 = Not detect,                    1 = Data finish detect	0
Busy Finish (BusyFin)	[3] R/C	Only busy check finish. This flag is cleared by setting to one this bit 0 = Not detect,                    1 = Busy finish detect	0
Reserved	[2]	–	0
Tx Data progress On (TxDatOn)	[1]	Data transmit in progress 0 = Not active,                    1 = Data Tx in progress	0
Rx Data Progress On (RxDatOn)	[0]	Data receive in progress 0 = not active,                    1 = data Rx in progress	0

## SDI FIFO STATUS REGISTER (SDIFSTA)

Register	Address	R/W	Description	Reset Value
SDIFSTA	0x4600_0038	R	SDI FIFO status register	0x0

SDIFSTA	Bit	Description	Initial State
Reserved	[31:16]	–	–
FIFO Reset(FRST)	[16] C	Reset FIFO value. This bit is automatically clear. 0 = Normal mode, 1 = FIFO reset	0
FIFO Fail error (FFfail)	[15:14] R/C	FIFO fail error when FIFO occurs overrun/underrun data saving. This flag is cleared by setting to one these bits. 00 = Not detect, 01 = FIFO fail 10 = FIFO fail in the last transfer(only FIFO reset need) 11 = Reserved	0
FIFO available Detect for Tx (TFDET)	[13]	This bit indicates that FIFO data is available for transmit when DatMode is data transmit mode. If DMA mode is enable, SD host requests DMA operation. 0 = Not detect(FIFO full), 1 = Detect(0 ≤ FIFO ≤ 63)	0
FIFO available Detect for Rx (RFDET)	[12]	This bit indicates that FIFO data is available for receive when DatMode is data receive mode. If DMA mode is enable, SD host requests DMA operation. 0 = Not detect(FIFO empty), 1 = Detect(1 ≤ FIFO ≤ 64)	0
Tx FIFO Half Full (TFHalf)	[11]	This bit sets to 1 whenever Tx FIFO is less than 33byte. 0 = 33 ≤ Tx FIFO ≤ 64, 1 = 0 ≤ Tx FIFO ≤ 32	0
Tx FIFO Empty (TFEmpty)	[10]	This bit sets to 1 whenever Tx FIFO is empty. 0 = 1 ≤ Tx FIFO ≤ 64, 1 = Empty(0byte)	0
Rx FIFO Last Data Ready (RFLast)	[9] R/C	This bit sets to 1 when Rx FIFO occurs to behave last data of all block. This flag is cleared by setting to one this bit. 0 = Not received yet, 1 = Rx FIFO gets Last data	0
Rx FIFO Full (RFFull)	[8]	This bit sets to 1 whenever Rx FIFO is full. 0 = 0 ≤ Rx FIFO ≤ 63, 1 = Full(64byte)	0
Rx FIFO Half Full (RFHalf)	[7]	This bit sets to 1 whenever Rx FIFO is more than 31byte. 0 = 0 ≤ Rx FIFO ≤ 31, 1 = 32 ≤ Rx FIFO ≤ 64	0
FIFO Count (FFCNT)	[6:0]	Number of data(byte) in FIFO	0000000

**NOTE:** Although the last Rx data size is larger than remained count of FIFO data, you could read this data. If this event happens, you should clear FFfail field, and FIFO reset field

## SDI INTERRUPT MASK REGISTER (SDIIMSK)

Register	Address	R/W	Description	Reset Value
SDIIMSK	0x4600_003C	R/W	SDI interrupt mask register	0x0

SDICON	Bit	Description	Initial Value
Reserved	[31:19]	–	–
NoBusy Interrupt Enable (NoBusyInt)	[18]	Determines SDI generate an interrupt if busy signal is not active 0 = Disable, 1 = Interrupt enable	0
RspCrc Interrupt Enable (RspCrcInt)	[17]	Determines SDI generate an interrupt if response CRC check fails 0 = Disable, 1 = Interrupt enable	0
CmdSent Interrupt Enable (CmdSentInt)	[16]	Determines SDI generate an interrupt if command sent(no response required) 0 = Disable, 1 = Interrupt enable	0
CmdTout Interrupt Enable (CmdToutInt)	[15]	Determines SDI generate an interrupt if command response timeout occurs 0 = Disable, 1 = Interrupt enable	0
RspEnd Interrupt Enable (RspEndInt)	[14]	Determines SDI generate an interrupt if command response received 0 = Disable, 1 = Interrupt enable	0
RWaitReq Interrupt Enable (RWaitReqInt)	[13]	Determines SDI generate an interrupt if read wait request occur. 0 = Disable, 1 = Interrupt enable	0
IOIntDet Interrupt Enable (IOIntDetInt)	[12]	Determines SDI generate an interrupt if SD host receives SDIO Interrupt from the card(for SDIO). 0 = Disable, 1 = Interrupt enable	0
FFfail Interrupt Enable (FFfailInt)	[11]	Determines SDI generate an interrupt if FIFO fail error occurs 0 = Disable, 1 = Interrupt enable	0
CrcSta Interrupt Enable (CrcStaInt)	[10]	Determines SDI generate an interrupt if CRC status error occurs 0 = Disable, 1 = Interrupt enable	0
DatCrc Interrupt Enable (DatCrcInt)	[9]	Determines SDI generate an interrupt if data receive CRC failed 0 = Disable, 1 = Interrupt enable	0
DatTout Interrupt Enable (DatToutInt)	[8]	Determines SDI generate an interrupt if data receive timeout occurs 0 = Disable, 1 = Interrupt enable	0
DatFin Interrupt Enable (DatFinInt)	[7]	Determines SDI generate an interrupt if data counter is zero 0 = Disable, 1 = Interrupt enable	0

**SDI INTERRUPT MASK REGISTER (SDIIMSK) (Continued)**

SDICON	Bit	Description	Initial Value
BusyFin Interrupt Enable (BusyFinInt)	[6]	Determines SDI generate an interrupt if only busy check completes 0 = Disable, 1 = Interrupt enable	0
Reserved	[5]	–	0
TFHalf Interrupt Enable (TFHalfInt)	[4]	Determines SDI generate an interrupt if Tx FIFO fills half 0 = Disable, 1 = Interrupt enable	0
TFEmpty Interrupt Enable (TFEmptyInt)	[3]	Determines SDI generate an interrupt if Tx FIFO is empty 0 = Disable, 1 = Interrupt enable	0
RFLast Interrupt Enable (RFLastInt)	[2]	Determines SDI generate an interrupt if Rx FIFO has last data 0 = Disable, 1 = Interrupt enable	0
RFFull Interrupt Enable (RFFullInt)	[1]	Determines SDI generate an interrupt if Rx FIFO fills full 0 = Disable, 1 = Interrupt enable	0
RFHalf Interrupt Enable (RFHalfInt)	[0]	Determines SDI generate an interrupt if Rx FIFO fills half 0 = Disable, 1 = Interrupt enable	0

**SDI DATA REGISTER (SDIDATN)**

Register	Address	R/W	Description	Reset Value
SDIDAT0	0x4600_0040 (W, HW, B)	R/W	SDI data0 register	0x0
SDIDAT1	0x4600_0044 (Word)	R/W	SDI data1 register	0x0
SDIDAT2	0x4600_0048 (Word)	R/W	SDI data2 register	0x0
SDIDAT3	0x4600_004C (Word)	R/W	SDI data3 register	0x0

SDIDATn	Bit	Description	Initial State
Data Register	[31:0]	This field contains the data to be transmitted or received over the SDI channel	0x00000000

**NOTE:** In case that DMA Burst4 mode is enabled by setting SDIDCON [24], SDIDAT1 ~ SDIDAT3 are valid.



# 32 MEMORY STICK

## OVERVIEW

There are many types of media for storing and transferring data. Memory Stick is one of the popular media. The S3C24A0A supports Memory Stick specifications version 1.3. Four pins are dedicated for memory stick interface, which are Bus State (MS\_BS), Serial Data (MS\_SDIO), Serial Clock (MS\_SCLK) and Insertion Detect (MS\_INS).

## FEATURES

- Protocol is started by writing to the command register (TP\_CMD)
- Supports DMA
- BUSY timeout period can be controlled by setting the BSYCNT bit fields in control status register (CTRL\_STA)
- The output from FIFO is only little endian
- Built in 8-byte (2-word) FIFO buffers for Tx and Rx respectively
- Built in CRC circuit (can be turned on/ off)
- PCLK must be under 80MHz
- Supports automatic command execution (can be turn on/ off)
- Supports Memory Stick detection interrupt



**MEMORY STICK PROTOCOL**

Figure 32-1 and 2 shows the read/ write packet of Memory Stick. The memory stick host controller uses only PCLK as its source clock. The MS\_SCLK frequency is made by divided PCLK (1/1, 1/2, 1/4 or 1/8) and it is slower than 20MHz.

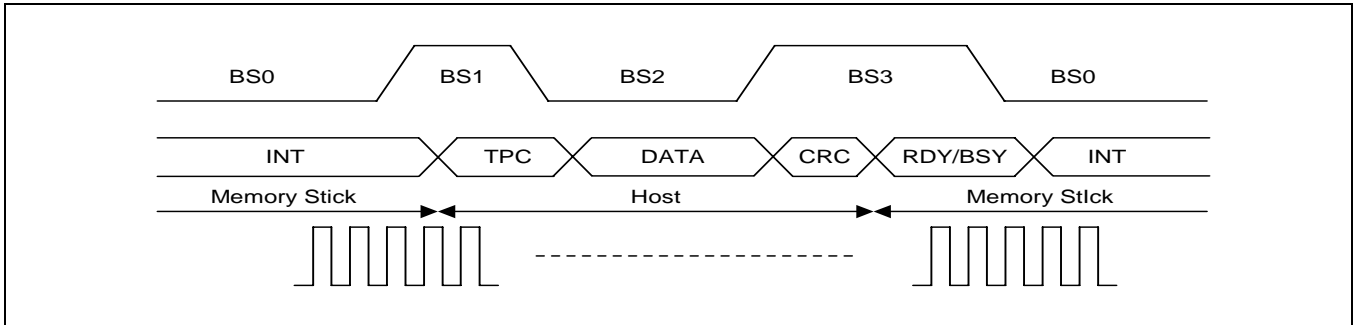

**Figure 32-1. Memory Stick Write Packet**

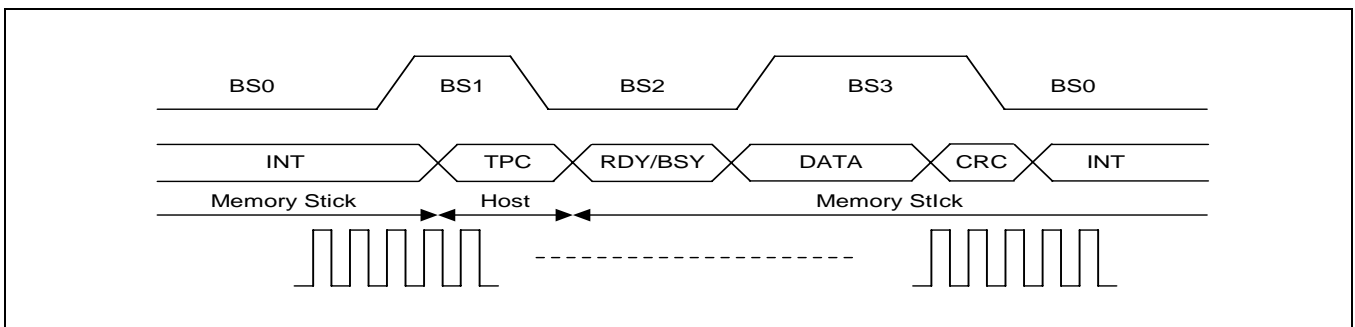

**Figure 32-2. Memory Stick Read Packet**

**MANDATORY HARDWARE CONFIGURATION**

The MS\_SDIO pin should be configured pull down resistor and the MS\_INS pin should be configured pull up resistor.

HOST BLOCK PIN DESCRIPTION

Pin Name	Function Name	Dir	Active	Description
XINT	Interrupt request	Out	Low	Interrupt request signal line Low level during interrupt request High level at access to IntDataReg
PI	Input parallel port	In	–	Parallel port for input only (used for insertion/extraction detect of Memory stick) Fixed in a High level when unused
RBE	Receive buffer empty	Out	High	High level when receive data buffer is empty Low level when there is data in receive data buffer
RBF	Receive buffer full	Out	High	High level when receive data buffer is full. Low level when there is space in receive data buffer
TBE	Transmit buffer empty	Out	High	High level when transmit data buffer is empty Low level when there is data in transmit data buffer
TBF	Transmit buffer full	Out	High	High level when transmit data buffer is full Low level when there is space in transmit data buffer

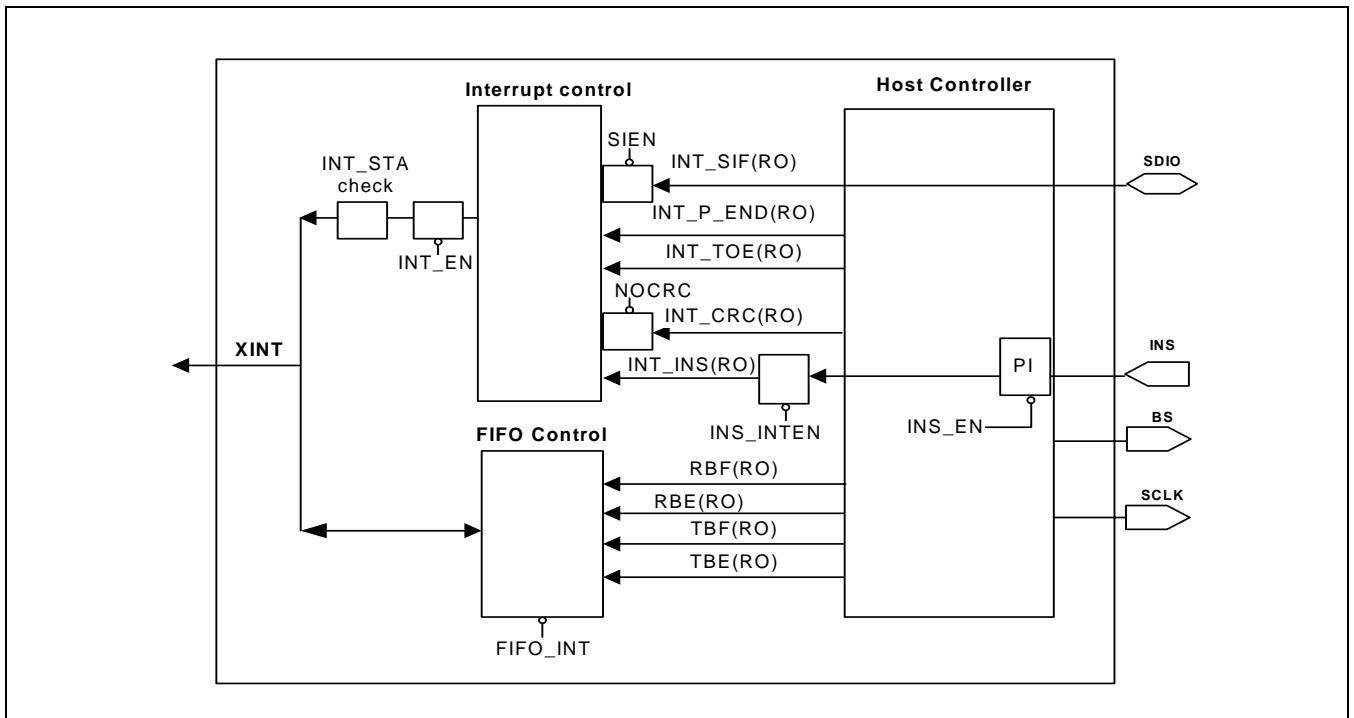

## MEMORY STICK SPECIAL REGISTERS

### PRESCALER CONTROL (MSPRE) REGISTER

Register	Address	R/W	Description	Reset Value
MSPRE	0x46100000	R/W	Pescaler control register	0x0

MSPRE	Bit	Description	Initial State
PRE_EN	[2]	Prescaler control 0 = Disable                      1 = Enable	0
PRE_VAL	[1:0]	Prescaler value 00 = 1/1                      01 = 1/2 10 = 1/4                      11 = 1/8 <b>Note:</b> MS_SCLK must be less than 20MHz	00

### FIFO INTERRUPT CONTROL (MSFINTCON) REGISTER

Register	Address	R/W	Description	Reset Value
MSFINTCON	0x46100004	R/W	FIFO interrupt control	0x0

MSINTCON	Bit	Description	Initial State
FIFO_INTEN	[0]	FIFO states, which are receive buffer full (RBF), receive buffer empty (RBF), transmit buffer full (TBF) and transmit buffer empty (TBF) request interrupt or do not. 0 = Only for XINT 1 = Enables interrupt request according to FIFO states <b>Note:</b> XINT means internal conditions, which are detecting protocol end interrupt (INT_P_END), serial interface interrupt (INT_SIF), Tx/ Rx request interrupt (INT_TR), and insertion interrupt (INT_INS).	0

## TRANSFER PROTOCOL COMMAND (TP\_CMD) REGISTER

Register	Address	R/W	Description	Reset Value
TP_CMD	0x46108000	R/W	Transfer protocol command register	0x0000

MSINTCON	Bit	Description	Initial State
TPC	[15:12]	Transfer protocol command 0x2 = Read page data 0xd = Write page data 0x8 = Set read/ write register address 0xe = Set command 0x7 = Get interrupt 0x4 = Read register 0xb = Write register Others = Reserved  <b>Note:</b> These bit fields can not be written while the INT_P_END bit in INTCON_STA register is '0'.	0x0
Reserved	[11:10]	Reserved	00
DAT_SIZE	[9:0]	Transferred data size 0x200 = Read/ write page data command 0x4 = Set read/ write register address 0x1 = Set command/ Get interrupt 0xX = Any data size to read/ write register	0x00



**CONTROL AND STATUS (CTRLSTA) REGISTER**

Register	Address	R/W	Description	Reset Value
CTRL_STA	0x46108004	R/W	Control [15:8] and staus [7:0] register	0x050a

MSCTRLSTA	Bit	Description	Initial State
RST	[15]	Internal logic reset control 0 = Clear reset      1 = Reset	0
PWS	[14]	Power save mode control 0 = Normal mode      1 = Power save mode	0
SIEN	[13]	Serial interface enable/ disable control 0 = Disable      1 = Enable	0
Reserved	[12]	Should be 0 (SBZ)	0
NOCRC	[11]	CRC enable/ disable control 0 = Enable      1 = Disable	0
BSYCNT	[10:8]	Busy timeout counter Timeout detecting time (MS_SCLK cycles) = BSYCNT x 4 + 2 Example: BSYCNT = 0x5, MS_SCLK = 10MHz Exceeding 2.2us (22 x 0.1) causes a RDY timeout error.	0x5
INT_STA (Read only)	[7]	Interrupt status 0 = Not generated interrupt condition 1 = Generated interrupt condition	0
DRQ_STA (Read only)	[6]	DMA request status 0 = Not requested DMA 1 = Requested DMA	0
Reserved	[5:4]	Reserved	00
RBE_STA (Read only)	[3]	Receive buffer (FIFO) empty status 0 = Not empty 1 = Empty	1
RBF_STA (Read only)	[2]	Receive buffer (FIFO) full status 0 = Not full 1 = Full	0
TBE_STA (Read only)	[1]	Transmit buffer (FIFO) empty status 0 = Not empty 1 = Empty	1
TBF_STA (Read only)	[0]	Transmit buffer (FIFO) full status 0 = Not full 1 = Full	0

**DATA FIFO (DAT\_FIFO) REGISTER**

Memory stick host controller has two 16-byte FIFO for the Tx and Rx mode. Transmit and receive FIFO access is performed through same FIFO entry: the address FIFOENTRY is 0x46108008.

Register	Address	R/W	Description	Reset Value
DAT_FIFO	0x46108008	R/W	Tx/ Rx FIFO (buffer) register	0x0000

MSFIFO	Bit	Description	Initial State
FIFOENTRY	[15:0]	Transmit/ receive data for memory stick	0x0000

**INTERRUPT CONTROL AND STATUS (INTCTRLSTA) REGISTER**

Register	Address	R/W	Description	Reset Value
INTCTRL_STA	0x4610800c	R/W	Interrupt control [15:8] and staus [7:0] register	0x0080

MSINTCTRLSTA	Bit	Description	Initial State
INT_EN	[15]	Internal enable/ disable control 0 = Disable                      1 = Enable	0
Reseved	[14]	Reseved	0
INS_INTEN	[13]	Insertion interrupt enable/ disable control 0 = Disable                      1 = Enable	0
Reserved	[12:8]	Reserved	0x00
INT_P_END (Read only)	[7]	Protocol end interrupt status 0 = In progress                  1 = Complete	1
INT_SIF (Read only)	[6]	Serial interface receive interrupt status(From Memory stick) 0 = No interrupt                  1 = Receive interrupt	0
Reseved	[5]	Reseved	0
INT_INS (Read only)	[4]	Insertion interrupt status 0 = No insertion                  1 = Insertion	0
Reserved	[3:2]	Reserved	00
INT_CRC (Read only)	[1]	CRC error interrupt status 0 = No CRC error                  1 = Occurred CRC error	0
INT_TOE (Read only)	[0]	Busy timeout error interrupt status 0 = No timeout error              1 = Occurred timeout error	0



**INS PORT CONTROL (INSCON) REGISTER**

Register	Address	R/W	Description	Reset Value
INS_CON	0x46108010	R/W	INS port control register	0x0000

MSINSCON	Bit	Description	Initial State
Reserved	[15:13]	Reserved	000
INS_EN	[12]	INS port enable/ disable control 0 = Disable                      1 = Enable	0
Reserved	[11:5]	Reserved	0x00
INS_STA	[4]	INS port status 0 = High (no insertion)   1 = Low (insertion)	0
Reserved	[3:0]	Reserved	0x0

**AUTO COMMAND/ POL CONTROL (ACMD\_CON) REGISTER**

Register	Address	R/W	Description	Reset Value
ACMD_CON	0x46108014	R/W	Auto command and polaiity control register	0x0000

MSACMDCON	Bit	Description	Initial State
ATPC_EN	[15]	Auto command operation enable/ disable control 0 = Disable                      1 = Enable	0
POL	[14]	Loading polarity control of the serial data input 0 = Rising edge                1 = Falling edge	0
Reserved	[13:0]	Reserved	0x00

**AUTO TRANSFER PROTOCOL COMMAND (ATP\_CMD) REGISTER**

Register	Address	R/W	Description	Reset Value
ATP_CMD	0x46108018	R/W	Auto transfer protocol command register	0x7001

MSACMD	Bit	Description	Initial State
ATPC	[15:12]	Set transfer protocol command (TPC) to be automatically executed.	0x7
Reserved	[11:10]	Reserved	0x0
ADAT_SIZE	[9:0]	Set the size of data which is transferred.	0x01



# 33

## CLOCK & POWER MANAGEMENT

### OVERVIEW

The Clock & Power management unit consists of 3 parts; System Clock Control, USB Clock Control, and System Power-management Control.

The System Clock Control logic in S3C24A0A can generate the required system clock signals, ARMCLK for CPU, HCLK for the AHB-bus peripherals, and PCLK for the APB-bus peripherals. There are two PLLs in S3C24A0A. One is for ARMCLK, HCLK, and PCLK, and the other is for the USB, IrDA and Camera Interface. The clock control-logic can make slow clock without PLL and connect/disconnect the clock to each peripheral block by software, which will reduce the power consumption.

In the power control logic, S3C24A0A has various power management schemes to keep optimal power consumption for a given task. The power management in S3C24A0A consists of four modes: General Clock Gating (NORMAL) mode, IDLE mode, STOP mode, and SLEEP mode.

General Clock Gating mode is used to control the On/Off of clocks for internal peripherals in S3C24A0A. The user can optimize the power consumption of S3C24A0A using this General Clock Gating mode by supplying clocks for peripherals that are necessary for a certain application. For example, if a timer is not needed, the user can disconnect the clock to the timer to reduce power.

IDLE mode disconnects the ARMCLK only to CPU core while it supplies the clock to all peripherals. By using IDLE mode, the power consumption due to CPU core can be reduced.

STOP mode freezes all clocks to the CPU as well as peripherals by disabling PLLs. The power consumption is only due to the leakage current in S3C24A0A.

SLEEP mode is intended to disconnect the internal power. So, the power consumption due to CPU and the internal logic except the wake-up logic will be zero in the SLEEP mode. In order to use the SLEEP mode two independent power sources are needed. One of the two power sources supplies the power for the wake-up logic. The other one supplies the other internal logic including CPU, and should be controlled in order to be turned on/off. In SLEEP mode, the second power supply source for the CPU and internal logic will be turned off.

A detailed description of the power-saving modes such as the entering sequence to the specific power-down mode or the wake-up sequence from a power-down mode is given in the following Power Management section.



**FUNCTION DESCRIPTION**

**CLOCK Generation Overview**

Figure 33-1 shows the block diagram of the clock generation module. The main clock source comes from an external crystal (XsXTIN) or external clock (XsEXTCLK). The clock generator consists of two PLLs (Phase-Locked-Loop) which generate the high-frequency clock signals required in S3C24A0A.

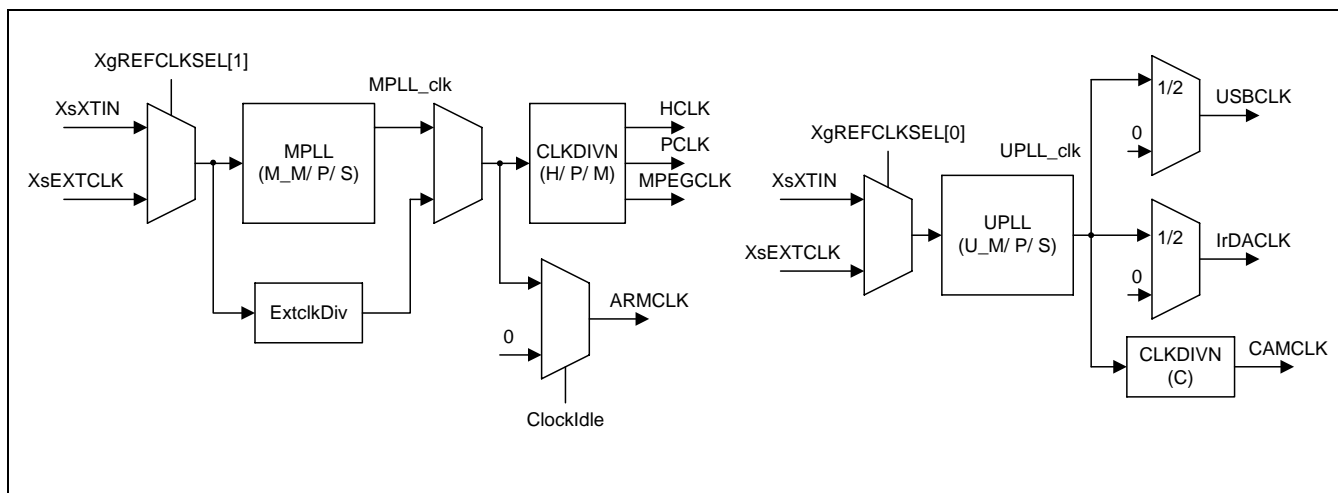

**Figure 33-1. Clock Generator Block Diagram**

**CLOCK Source Selection**

Table 33-1 shows the relationship between the combination of mode control pins XgREFCLKSEL[1:0] and the selection of source clock for S3C24A0A. (see the Figure 33-1.)

**Table 33-1. Clock Source Selection for the Internal PLLs and Clock Generation Logic**

XgREFCLKSEL[1:0] (refer to Pin Description)	Main Clock source (MPLL and External Clock)	USB Clock source (UPLL and External Clock)
00	XsXTIN	XsXTIN
01	XsXTIN	XsEXTCLK
10	XsEXTCLK	XsXTIN
11	XsEXTCLK	XsEXTCLK

**NOTES:**

- Although the MPLL/UPLL starts just after a reset, the MPLL output (MPLL\_clk) isn't used as the system clock until the S/W writes valid settings to the MPLLCON / UPLLCON register. Before this valid setting, the clock from XsXTIN or XsEXTCLK source will be used as the system clock directly. Even if the user wants to maintain the default value of MPLLCON / UPLLCON register, the user should write the same value into MPLLCON / UPLLCON register.
- MPLL generates the clock source for ARMCLK, HCLK, PCLK and UPLL generates clock source for USBCLK, IrDACLK and CAMCLK.

### PLL (Phase-Locked-Loop)

The PLL (Phase-Locked Loop) frequency synthesizer is constructed in CMOS on single monolithic structure. The PLL provides frequency multiplication capabilities the output clock frequency MPLL\_clk is related to the input clock frequency Fin by the following equation:

$$F_{out} \text{ (MPLL\_clk or UPLL\_clk)} = (m * F_{in}) / (p * 2^s)$$

Where,

$m = M$  (the value for Main Divider)+ 8,  $p = P$  (the value for Pre-Divider P) + 2

Where, Fout is the output clock frequency. Fin the input frequency. M, P and S are the values for programmable dividers (see the register description). The PLL consists of a Phase/Frequency Detector (PFD), a Charge Pump, an Off-chip Loop Filter, a Voltage Controlled Oscillator (VCO), a 6 bit pre-divider, an 8bit main divider and 2-bit post scaler and shown in Figure 33-2

The UPLL within the clock generator is same as the MPLL in every aspect.

To ensure the proper operation of the internal PLLs, we recommend the following PLL value-sets(refer to Table 33-7). If the user requires other range of PLL set-values, please contact one of SEC application engineers.

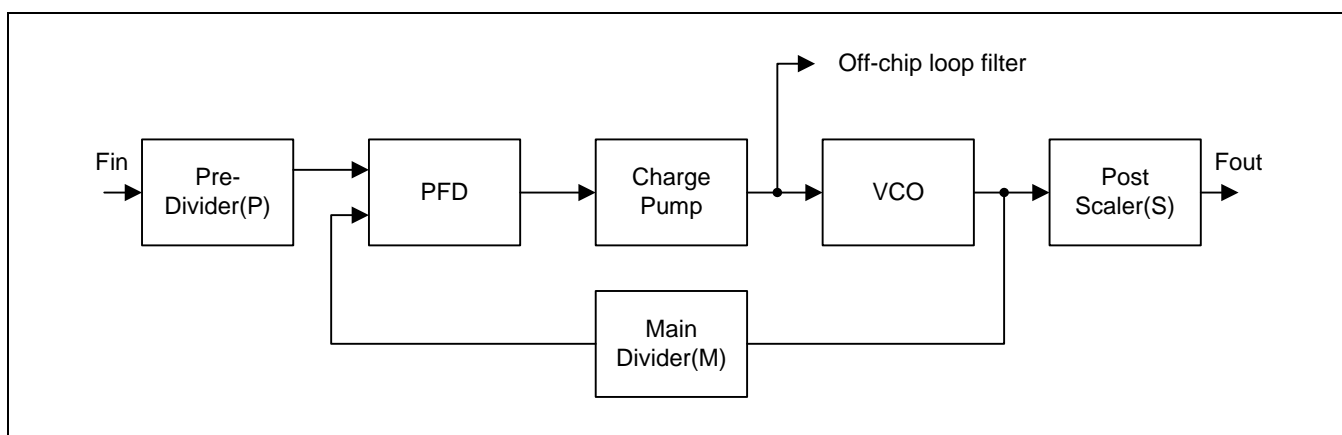

Figure 33-2. PLL (Phase-Locked Loop) Block Diagram

## Usual Conditions for PLL &amp; Clock Generator

Table 33-2. Recommended operation conditions

Characteristics	Min	Typ	Max	Unit
Supply voltage differential	-0.1		0.1	V
External loop filter capacitance		1.7		nF
Operating temperature	-40		85	°C

Table 33-3. DC Electrical Characteristics

Characteristics	Symbol	Min	Typ	Max	Unit
Operating voltage	AVDD12D/AVDD12A	1.14	1.20	1.26	V
Dynamic current	$I_{DD}$			3	mA
Power down current	$I_{PD}$		TBD		μA

Table 33-4. AC Electrical Characteristics

Characteristics	Symbol	Min	Typ	Max	Unit
Input frequency	$F_{IN}$	10		40	MHz
Output clock frequency	$F_{out}$	50		200	MHz
VCO output frequency	$F_{VCO}$	100		300	MHz
Input clock duty cycle	$T_{ID}$	40	50	60	%
Input glitch pulse width	$T_{IGP}$			1	ns
Jitter, cycle to cycle	$T_{JCC}$	200		200	ps

## CLOCK Control Logic

The clock control logic determines the clock source to be used, i.e., the PLL clock(MPLL\_clk) or the direct external clock ( XsXTIN or XsEXTCLK ). When PLL is configured to a new frequency value, the clock control logic disables the ARMCLK until the PLL output is stabilized during the PLL locking time. The clock control logic is also activated at power-on reset and waked-up from power-down mode.

## PLL Lock Time

The lock time is the minimum time required for PLL output stabilization. The lock time should be a minimum of 300us. After reset and wake-up from STOP and SLEEP mode, respectively, the lock-time is inserted automatically by the internal logic with lock time count register. The automatically inserted lock time is calculated as follows;

$$t_{lock} \text{ (the PLL lock time by H/W logic)} = (1/F_{in}) \times n$$

where,  $n = M\_LTIME$  for MPLL,  $U\_LTIME$  for UPLL, refer to the register description

### Power-On Reset (XsRESETn)

Figure 33-3 shows the clock behavior during the power-on reset sequence. The crystal oscillator begins oscillation within several milliseconds after the power source supplies enough power-level to the S3C24A0A. Internal PLLs (MPLL and UPLL) also begins the frequency locking based on power-on-reset frequency-setting value. XsRESETn signal should be released after the fully settle-down of the power-level. For the proper system operation, the S3C24A0A requires a hazard-free system clock (ARMCLK, HCLK and PCLK) when the system reset is released (XsRESETn). However, the PLL is commonly known to be unstable after power-on reset, so Fin (the direct external clock source, XsXTIN or XsEXTCLK depending on the XgREFCLKSEL[1:0] pin status) is fed directly to ARMCLK instead of the MPLL\_clk (PLL output) before the S/W newly configures the MPLLCON register. Even if the user wants to use the default value of MPLLCON register, user should write the same value into MPLLCON register by S/W after the release of the system reset.

The PLL begins the lockup sequence toward the new frequency only after the S/W configures the PLL with a new frequency-value. ARMCLK is configured to be PLL output (MPLL\_clk) immediately after lock time.

The user should be aware that the crystal oscillator settle-down time is not explicitly added by the hardware during the power-up sequence. The S3C24A0A assumes that the crystal oscillation is settled during the power-supply settle-down period. However, to ensure the proper operation during wake-up from the STOP mode, the S3C24A0A explicitly adds the crystal oscillator settle-down time (the wait-time can be programmed using the XTALWSET registers) after wake-up from the STOP mode.

For the USB, IrDA and Camera Interface device clocks, the output of UPLL clock is directly fed to those devices.

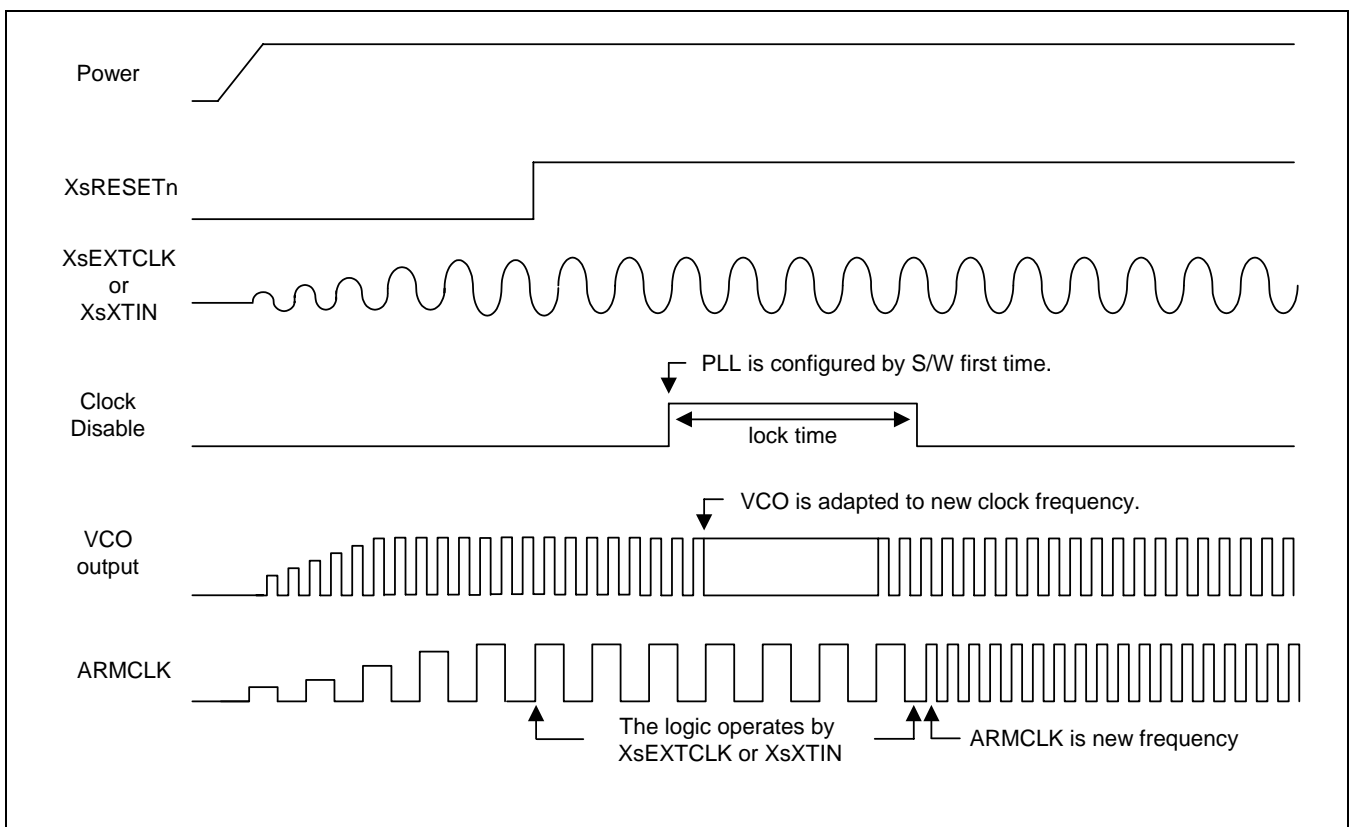

Figure 33-3. Power-On Reset Sequence

### Change PLL Settings In Normal Operation

During the operation of S3C24A0A in NORMAL mode, if the user wants to change the frequency by writing the PMS value, the PLL lock time is automatically inserted. During the lock time, the clock is not supplied to the internal blocks in S3C24A0A. The timing diagram is as follow.

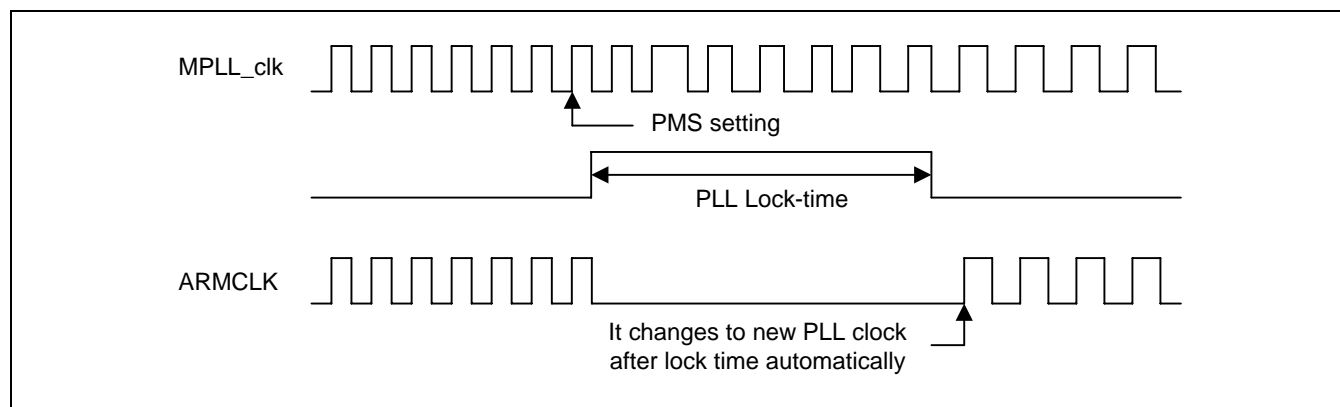

Figure 33-4. The Case that Changes Slow Clock by Setting PMS Value

#### NOTE

Changing PMS value can cause a problem in LCD display. In the S3C24A0A, the LCD screen-refresh timing is dependent on the HCLK (HCLK clock is also dependent on the MPLL clock output).

### ARMCLK, HCLK, PCLK, MPEGCLK and CAMCLK Control

The ARMCLK is used for ARM926EJ-S core, the main CPU of the S3C24A0A. The HCLK is the reference clock for internal AHB bus and peripherals such as the memory controller, the interrupt controller, the Modem Interface, LCD controller, the DMA, USB host block, System Controller, Power down controller and etc. The PCLK is used for internal APB bus and peripherals such as WDT, IIS, I2C, PWM timer, and MMC interface, ADC, UART, GPIO, RTC and SPI etc. MPEGCLK is used for MPEG4 H/W accelerator block such as DCT, ME, MC block. CAMCLK is used for camera interface block.

The following table shows the clock division ratios between ARMCLK, HCLK and PCLK. This ratio is determined by HDIV and PDIV bits of CLKDIVN control register.

HCLKdiv[1:0]	PCLKdiv	ARMCLK	HCLK	PCLK	Division Ratio
00	0	ARMCLK	ARMCLK	ARMCLK	1 : 1 : 1 (Default)
00	1	ARMCLK	ARMCLK	ARMCLK / 2	1 : 1 : 2
01	0	ARMCLK	ARMCLK / 2	ARMCLK / 2	1 : 2 : 2
01	1	ARMCLK	ARMCLK / 2	ARMCLK / 4	1 : 2 : 4
10	0	ARMCLK	ARMCLK / 3	ARMCLK / 3	1 : 3 : 3
10	1	ARMCLK	ARMCLK / 3	ARMCLK / 6	1 : 3 : 6
11	0	ARMCLK	ARMCLK / 4	ARMCLK / 4	1 : 4 : 4
11	1	ARMCLK	ARMCLK / 4	ARMCLK / 8	1 : 4 : 8



MPEGCLK and CAMCLK frequency are determined by MPEGCLKdiv[3:0] and CAMCLKdiv[3:0] bits of CLKDIVN control register.

MPEG or CAMCLKdiv[3:0]	MPEGCLK	CAMCLK
0	HCLK	UPLL_clk
1~15	$HCLK / (2 \times \text{MPEGCLKdiv})$	$UPLL\_clk / (\text{CAMCLKdiv} + 1)$

The MPEGCLK and the CAMCLK frequency are changed whenever the source clock frequency is changed.

### UCLK (USB Clock) Control

USB host interface and USB device interface needs 48Mhz fixed-frequency clock. In the S3C24A0A, The USB dedicated PLL (UPLL) generates 96Mhz and divided by two for USB block. UPLL will be turned off during STOP and SLEEP mode automatically. Also, UPLL will be generated clock to USBCLK, IrDACLK, CAMCLK after exiting STOP and SLEEP mode if USBon, IrDAckOn and CAMckOn bits are enabled in CLKCON register.

Condition	UCLK state	UPLL State
After reset	UPLL output	on
After configuring UPLL	During PLL lock time: Low After PLL lock time: UPLL output	on
UPLL is turned off by U_PLLOff bit in CLKSRC register	No clock	off
UPLL is turned on by U_PLLOff bit in CLKSRC register	UPLL output	on

**NOTE:** UPLL\_clk (UPLL output) is 98MHz. USBCLK is obtained by dividing by two of UPLL\_clk, i.e. UPLL\_clk/2.



**Power Management**

The power management block controls the system clocks by software for the reduction of power consumption in S3C24A0A. These schemes are related to PLL, clock control logic(ARMCLK,HCLK,PCLK) and wake-up signal. The Figure 33-5 depicts the clock distribution of S3C24A0A.

S3C24A0A has four power-down modes. The following section describes each power management mode.

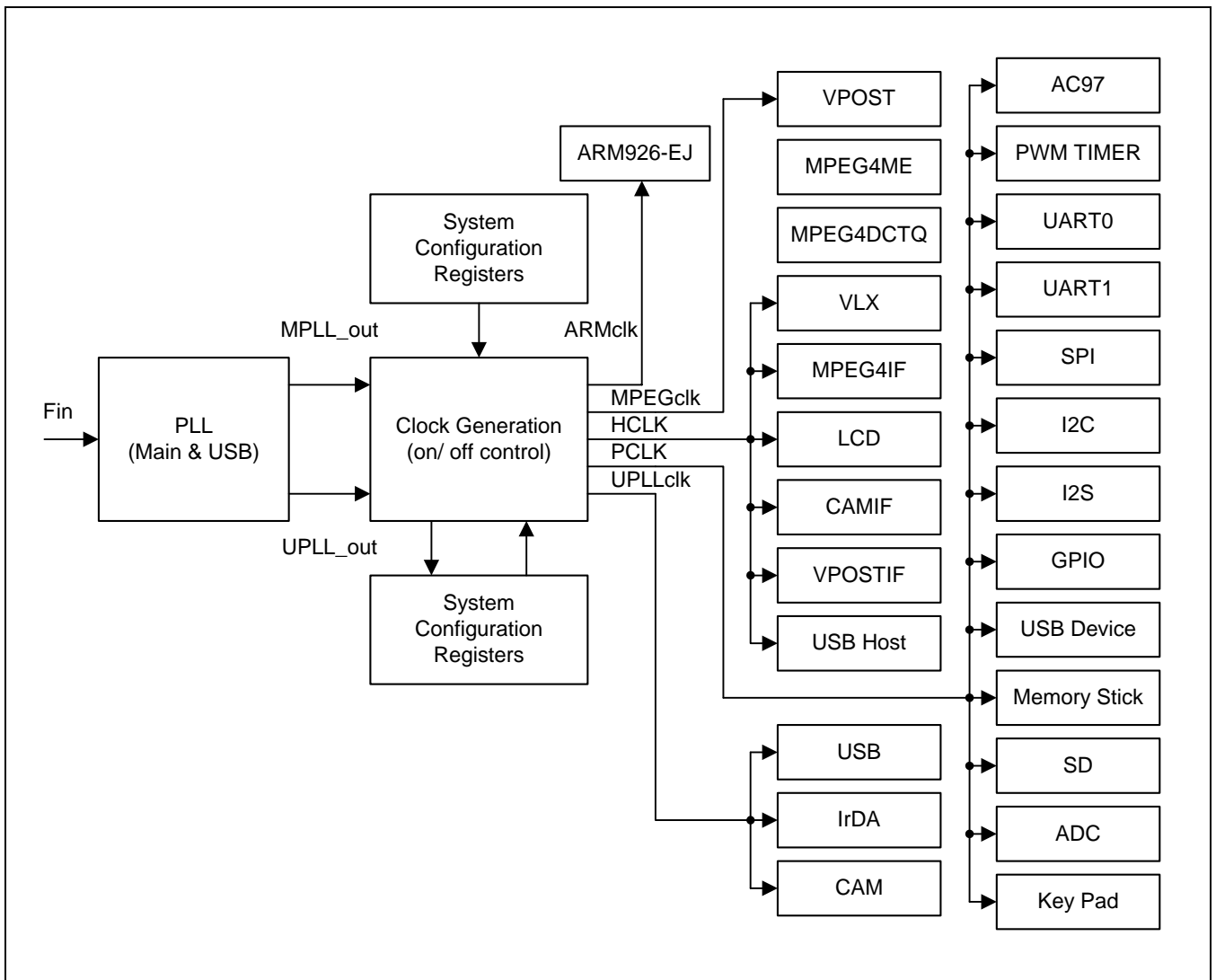

Figure 33-5. The Clock Distribution Block Diagram



## POWER SAVING MODES

### General Clock Gating Mode

In General Clock Gating mode, the On/Off clock gating of the individual clock source of each IP block is performed by controlling of each corresponding clock source enable bit. The Clock Gating is applied instantly whenever the corresponding bit (or bits) is changed. (In general, these bits are set or cleared by the main CPU.)

### IDLE Mode

In IDLE mode, the clock to CPU core is stopped. The IDLE mode is activated just after the execution of the STR instruction that enables the IDLE Mode bit. The IDLE Mode bit should be cleared by software after the wake-up from the IDLE state because it is not cleared automatically, and the H/W logic only detects the low-to-high triggering of the IDLE Mode bit.

### STOP Mode

In STOP mode, all clocks are stopped for minimum power consumption. Therefore, the PLL and oscillator circuit are also stopped. The STOP Mode is activated after the execution of the STR instruction that enables the STOP Mode bit. The STOP Mode bit should be cleared by software after the wake-up from the STOP state because it is not cleared automatically, and the H/W logic only detects the low-to-high triggering of the STOP Mode bit.

To exit from STOP mode, External interrupt, RTC alarm, Modem INT, XsRESETn or XsWRESETn has to be activated. During the wake-up sequences, the crystal oscillator and PLL may begin to operate. The crystal-oscillator settle-down-time and the PLL locking-time is required to provide stabilized ARMCLK. Those time-waits are automatically inserted by the hardware of the S3C24A0A. During these time-waits, the clock is not supplied to the internal logic circuitry.

STOP mode Entering sequence is

1. Set the STOP Mode bit by software.
2. Set the SDRAM in self-refresh mode to preserve its contents (the Power-manager of S3C24A0A requests the entering of the self-refresh state to the SDRAM controller of S3C24A0A and it issues the self-refresh command.)
3. After receiving the self-refresh acknowledge, disables the X-tal and PLL oscillation.

STOP mode Exiting sequence is

1. Enable X-tal Oscillator if it is used, and wait the OSC settle down (around 1ms).
2. After the Oscillator settle-down, the System Clock is fed using the PLL input clock and also enable the PLLs and waits the PLL locking time.
3. Switching the clock source, now the PLL is the clock source.
4. The SDRAM controller releases the self-refresh mode just before the S3C24A0A access the SDRAM.

#### NOTES:

1. DRAM has to be in self-refresh mode during STOP and SLEEP mode to retain valid memory data.
2. LCD must be stopped before STOP and SLEEP mode, because DRAM can't be accessed when it is in self-refresh mode.

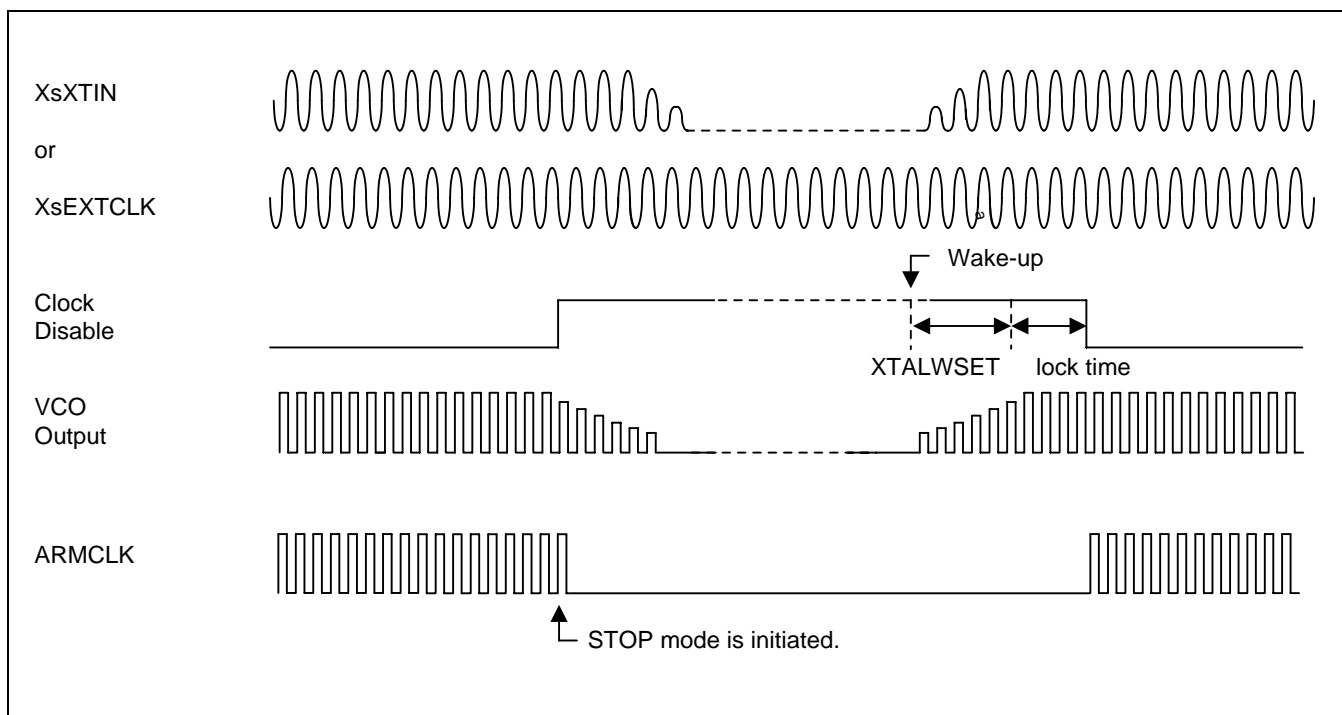

Figure 33-6. Entering STOP Mode and Exiting STOP mode (Wake-up)

### SLEEP Mode

In the SLEEP Mode, all the clock sources are off and also the internal logic-power is not supplied except for the wake-up logic circuitry. In this mode, the static power-dissipation of internal logic can be minimized.

SLEEP Mode Entering sequence is as follows.

1. One of the SLEEP Mode entering events is triggered by the system software or by the hardware.
2. Set the SDRAM in self-refresh mode to preserve its contents (the Power-manager of S3C24A0A requests the entering of the self-refresh state to the SDRAM controller of S3C24A0A and it issues the self-refresh command.).
3. After receiving the self-refresh acknowledge, disables the X-tal and PLL oscillation and also disables the external power source for the internal logic by asserting XgPWROFFn signal to low state. XgPWROFFn signal is the regulator-disable control signal for the internal-logic power-source.

SLEEP Mode Exiting sequence is as follows.

1. Enable external power source by deactivation of the XgPWROFFn signal and wait power settle down time (around 6ms, it is programmable by a register in the GPIO block).
2. Release the System Reset (synchronously, relatively to the system clock) after the power supply is stabilized (see the GPIO descriptions).
3. The SDRAM controller releases the self-refresh mode just before the S3C24A0A access the SDRAM.



**Power Mode State Diagram**

Figure 33-7 show that Power Saving mode state and Entering or Exiting condition. In general, the S3C24A0A issues the Entering conditions.

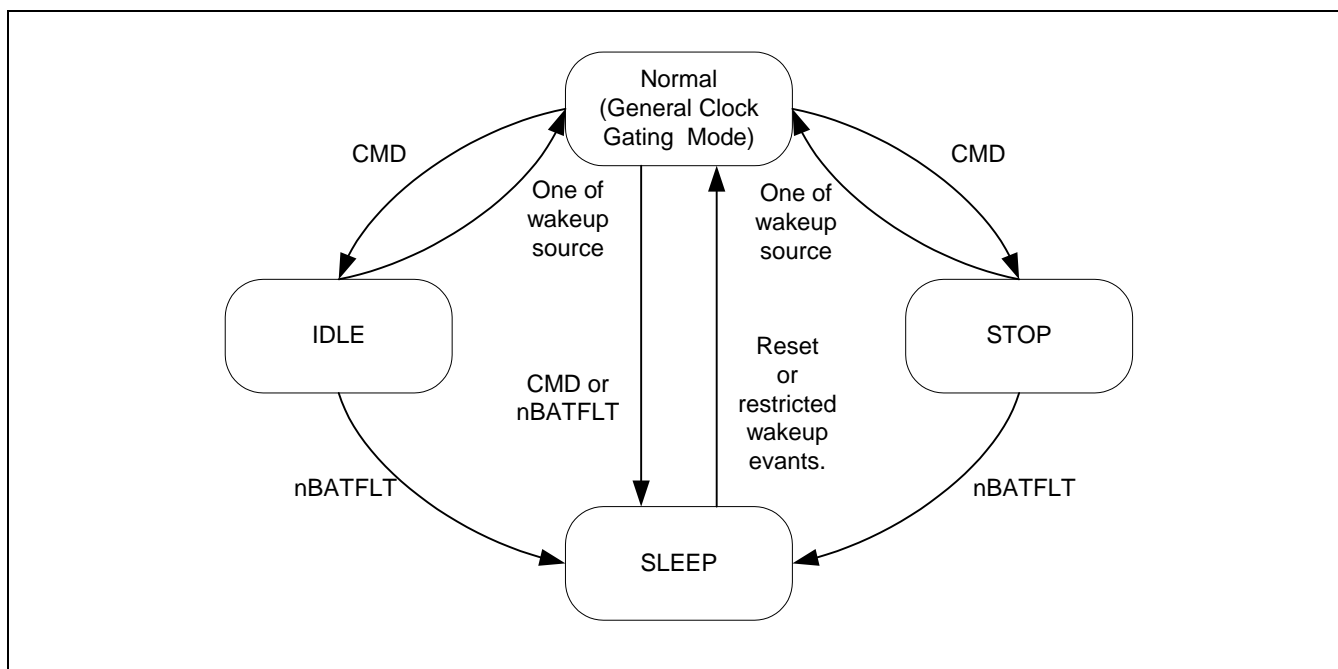

**Figure 33-7. Power mode state diagram**

**Wake-Up Event**

When the S3C24A0A wakes up from the STOP Mode or the SLEEP Mode by an External Interrupt, a RTC alarm interrupt and other interrupts, the PLL is turned on automatically. However, the clock supply scheme is quite different. The initial-state of the S3C24A0A after wake-up from the SLEEP Mode is almost the same as the Power-On-Reset state except for the contents of the external DRAM is preserved. In contrast, the S3C24A0A automatically recovers the previous working state after wake-up from the STOP Mode.

The following table shows the states of PLLs and internal clocks after wake-ups from the power-saving modes.

**Table 33-5. The Status of PLL and ARMCLK After Wake-Up**

Mode before wake-up	PLL on/off after wake up	ARMCLK after wake up and before the lock time	ARMCLK after the lock time by internal logic
IDLE	Unchanged	PLL Output	PLL Output
STOP	Off → on	No clock	PLL Output
SLEEP	Off → on	External Clock	External Clock

**Output port state in STOP and SLEEP mode**

Refer to Pin Assignment Table \* in Product Overview chapter.

**Power Saving Mode Entering/Exiting Condition**

Table 33-6 shows that Power Saving mode state and Entering or Exiting condition.

**Table 33-6. Power Saving Mode Entering/Exiting condition**

Power Saving Mode	Entering	Exiting
NORMAL	Disable the CLKCON bit for each IP block	Enable the CLKCON bit for each IP block
IDLE	Enable the ClockIdle bit of CLKCON register	1) All Interrupt 2) XsWRESETn 3) XsRESETn
STOP	Enable the ClockStop bit of CLKCON register	1) External INT[9:0] 2) RTC Alarm INT 3) Modem INT 4) XsWRESETn 5) XsRESETn
SLEEP	Write '0xA3' to the SLEEP_CODE[7:0] bits of PWRMAN register	1) External INT[9:0] 2) RTC Alarm INT 3) XsWRESETn 4) XsRESETn
SLEEP	When the XgBATFLT port goes to low	1) External INT: GPIO[1:0] 2) XsWRESETn 3) XsRESETn

**NOTES:**

- The Wake-up Event Sources for the SLEEP mode due to the XgBATFLT are limited as in the above table.
- Entering to the SLEEP mode by the XgBATFLT is programmable,
  - the XgBATFLT can be forwarded as an FIQ
  - the XgBATFLT can be used as the entering event for the SLEEP mode
  - the XgBATFLT can be ignored.

**Reset Definition**

Reset	Definition
XsRESETn	This is the cold reset. The internal state (include registers) of the S3C24A0A will be initialized when XsRESETn is activated. The XsRESETn is a non-maskable signal except for the case when the XgBATFLTn is in the active state (low). The contents of the SDRAM will not be preserved when the XsRESETn is applied.
XsWRESETn, SoftReset	The XsWRESETn and the Soft-reset reset the system except RTC, Clock Generator, power management module and memory controller (preserves SDRAM data)



**CLOCK GENERATOR & POWER MANAGEMENT SPECIAL REGISTER****LOCK TIME COUNT REGISTER (LOCKTIME)**

Register	Address	R/W	Description	Reset Value
LOCKTIME	0x40000000	R/W	PLL lock time count register	0x0FFF_0FFF

LOCKTIME	Bit	Description	Initial State
U_LTIME	[27:16]	UPLL lock time count (generally 300us)	0xFFFF
M_LTIME	[11:0]	MPLL lock time count (generally 300us)	0xFFFF

**PLL Locking Time**

$$\text{Locking Time} = (1/\text{Fin}) \times (\text{U\_LTIME or M\_LTIME} \times 16)$$

**X-TAL OSCILLATION WAIT REGISTER (XTALWSET)**

Register	Address	R/W	Description	Reset Value
XTALWSET	0x40000004	R/W	Crystal oscillator settle-down wait time	0x5000_5000

XTALWSET	Bit	Description	Initial State
U_OSCWAIT	[31:16]	UPLL Crystal oscillator settle-down wait time	0x5000
M_OSCWAIT	[15:0]	MPLL Crystal oscillator settle-down wait time	0x5000

**X-tal Settle-Down Wait Time**

$$\text{X-tal Settle-down Time} = T_{\text{crystal\_clock}} \times (\text{U\_OSCWAIT or M\_OSCWAIT})$$

**PLL CONTROL REGISTER (MPLLCON, UPLLCON)****PLL Value Selection Guide**

1.  $M_{pll}$  or  $U_{pll} = (m \times F_{in}) / (p \times 2^s)$ , where:  $m = (MDIV + 8)$ ,  $p = (PDIV + 2)$ ,  $s = SDIV$
2.  $F_{in}/(25 \times p) < 16.7e6/m < F_{in}/(10 \times p)$
3.  $0.7 < 6.48/\sqrt{m} < 1.8$
4.  $(F_{in}/p) \times m < 330e6$

Register	Address	R/W	Description	Reset Value
MPLLCON	0x40000010	R/W	MPLL configuration register	0x0004_8021
UPLLCON	0x40000014	R/W	UPLL configuration register	0x0003_0021

M/U PLLCON	Bit	Description	Initial State
MDIV	[19:12]	Main divider control ( M value )	0x48 / 0x30
PDIV	[9:4]	Pre-divider control ( P value )	0x02 / 0x02
SDIV	[1:0]	Post divider control ( S value )	0x1 / 0x1

To ensure the proper operation of the internal PLLs, we recommend the following PLL value-sets. If the user requires other range of PLL set-values, please contact one of SEC application engineers.

**Table 33-7. PLL value selection table**

Input Frequency	Output Frequency (MHz)	MDIV	PDIV	SDIV
12.00MHz	84	34 (0x22)	1	1
12.00MHz	90	37 (0x25)	1	1
12.00MHz	96	56 (0x38)	2	1
12.00MHz	102	43 (0x2b)	1	1
12.00MHz	112.5	67 (0x43)	2	1
12.00MHz	118	51 (0x33)	1	1
12.00MHz	124	54 (0x36)	1	1
12.00MHz	132	58 (0x3a)	1	1
12.00MHz	136	60 (0x3c)	1	1
12.00MHz	176	36 (0x24)	1	0
12.00MHz	177	51 (0x33)	2	0
12.00MHz	180	37 (0x25)	1	0
12.00MHz	186	54 (0x36)	2	0
12.00MHz	192	56 (0x38)	2	0
12.00MHz	200	42 (0x2a)	1	0
12.00MHz	204	60 (0x3c)	2	0



## CLOCK CONTROL REGISTER (CLKCON)

Register	Address	R/W	Description	Reset Value
CLKCON	0x40000020	R/W	Clock generator control Register	0x03ffff0

CLKCON	Bit	Description	Initial State
VLXclkOn	[29]	Controls HCLK into VLX block 0 = Disable 1 = Enable	1
VPOSTclkOn	[28]	Controls MPEGCLK into VPOST block 0 = Disable 1 = Enable	1
Reserved	[27]	Reserved	
MPEGDCTQclkOn	[26]	Controls MPEGCLK into MPEGDCTQ block 0 = Disable 1 = Enable	1
VPOSTIFclkOn	[25]	Controls HCLK into VPOST block (AHB bus side) 0 = Disable 1 = Enable	1
MPEGIFclkOn	[24]	Controls HCLK into MPEG AHB Interface 0 = Disable 1 = Enable	1
CAMclkOn	[23]	Controls UPLL_clk into CAM block 0 = Disable 1 = Enable	1
LCDclkOn	[22]	Controls HCLK into LCD block 0 = Disable 1 = Enable	1
CAMIFclkOn	[21]	Controls HCLK into camera interface block 0 = Disable 1 = Enable	1
MPEGMEclkOn	[20]	Controls MPEG4CLK into MPEG ME block 0 = Disable 1 = Enable	1
KeyPadClkOn	[19]	Controls PCLK into Key Pad block 0 = Disable 1 = Enable	1
ADCclkOn	[18]	Controls PCLK into ADC block 0 = Disable 1 = Enable	1
SDclkOn	[17]	Controls PCLK into SD block 0 = Disable 1 = Enable	1
MScIkOn	[16]	Controls PCLK into Memory Stick block 0 = Disable 1 = Enable	1
USBdeviceClkOn	[15]	Controls PCLK into USB device block 0 = Disable 1 = Enable	1
GPIOclkOn	[14]	Controls PCLK into GPIO block 0 = Disable 1 = Enable	1
IISclkOn	[13]	Controls PCLK into IIS block 0 = Disable 1 = Enable	1
IICclkOn	[12]	Controls PCLK into IIC block 0 = Disable 1 = Enable	1
SPIclkOn	[11]	Controls PCLK into SPI block 0 = Disable 1 = Enable	1





**CLOCK CONTROL REGISTER (CLKCON) (Continued)**

CLKCON	Bit	Description	Initial State
UART1clkOn	[10]	Controls PCLK into UART1 block 0 = Disable    1 = Enable	1
UART0clkOn	[9]	Controls PCLK into UART0 block 0 = Disable    1 = Enable	1
PWMTIMERCkOn	[8]	Controls PCLK into PWMTIMER block 0 = Disable    1 = Enable	1
USBhostClkOn	[7]	Controls HCLK into USB host block 0 = Disable    1 = Enable	1
AC97clkOn	[6]	Controls PCLK into AC97 block 0 = Disable    1 = Enable	1
Reserved	[5]	Reserved(Should be zero)	0
IrDAclkOn	[4]	Controls UPLL_clk into IrDA block 0 = Disable    1 = Enable	1
Reserved	[3]	Reserved	0
ClockIdle	[2]	Enters IDLE mode. This bit is not cleared automatically. 0 = Disable    1 = Transition to IDLE mode	0
ClkMonOn	[1]	HCLK monitor Enable 0 = Disable    1 = Enable	0
ClockStop	[0]	Enters STOP mode. This bit is not cleared automatically. 0 = Disable    1 = Transition to STOP mode	0



**CLOCK SOURCE CONTROL REGISTER (CLKSRC)**

Register	Address	R/W	Description	Reset Value
CLKSRC	0x40000024	R/W	Clock source control register.	0x00000004

CLKSRC	Bit	Description	Initial State
OnOSC_EN	[8]	Crystal Oscillator Enable control during the STOP mode 0 = Disable    1 = Enable	0
U_PLLoff	[7]	UPLL on/off control 0 = on        1 = off	0
Reserved	[6]	Reserved	0
M_PLLoff	[5]	MPLL on/off control 0 = on        1 = off	0
SelExtClk	[4]	Select External clock source for ARMCLK/HCLK/PCLK 0 = MPLL_clk    1 = External clock	0
Reserved	[3]	Reserved	0
ExtclkDiv	[2:0]	External clock division factor 000 = No division    001 ~ 110: Divided by (2×ExtClkDiv) 111 = Reserved for the S3C24A0A test	4



**SOFTRESET CONTROL REGISTER (SOFTRESET)**

Register	Address	R/W	Description	Reset Value
SOFTRESET	0x40000038	R/W	Software reset control register	–

SOFTRESET	Bit	Description	Initial State
Soft Reset	[7:0]	Software controlled reset setting code	–

**NOTE:** SOFTRESET command is 0xA3. When this register was set with the value of 0xFFFF\_XXA3 the soft-reset is activated.

## NOTES



# 34 MECHANICAL DATA

## PACKAGE DIMENSIONS

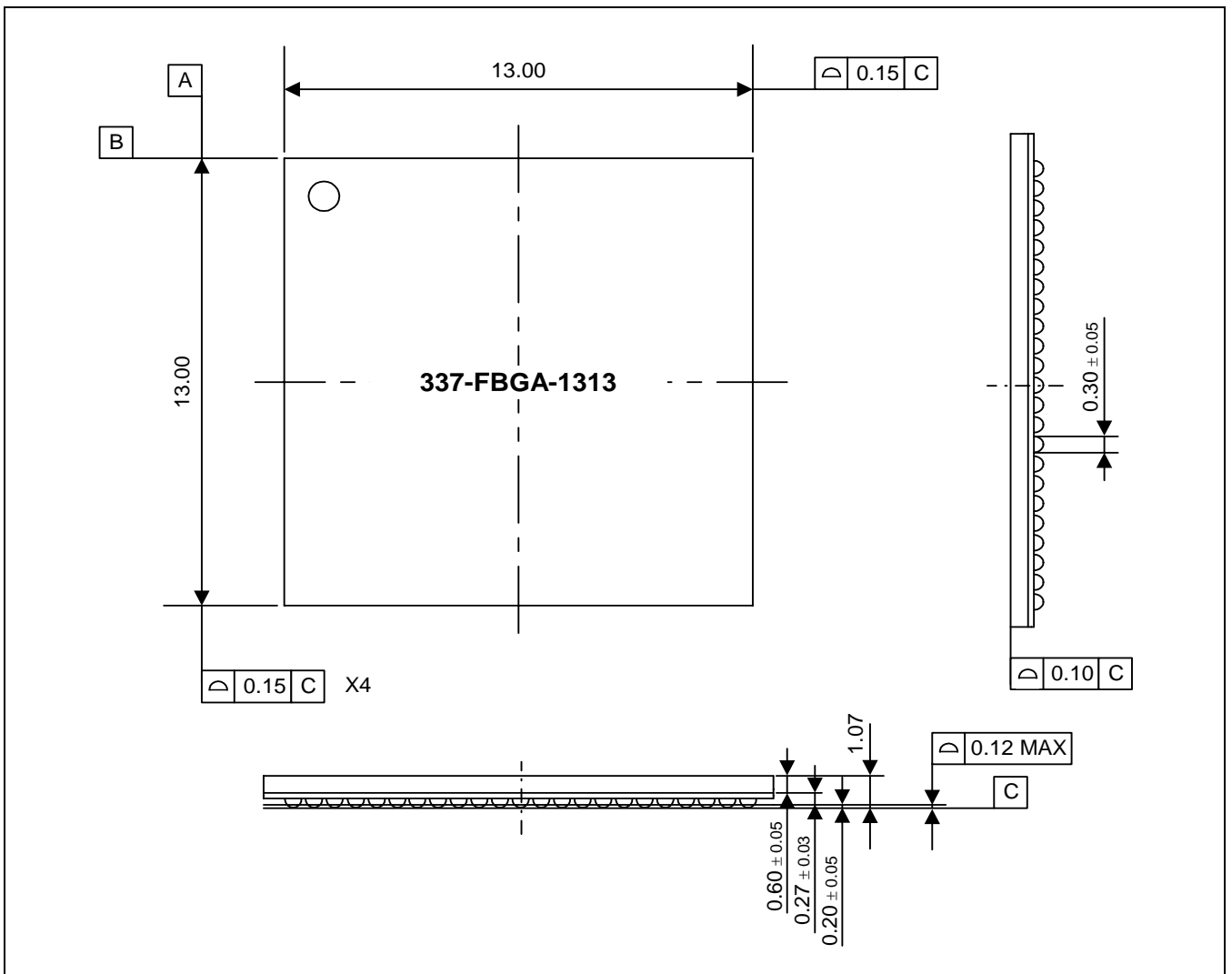

Figure 34-1. 337-FBGA-1313 Package Dimension 1 (Top View)



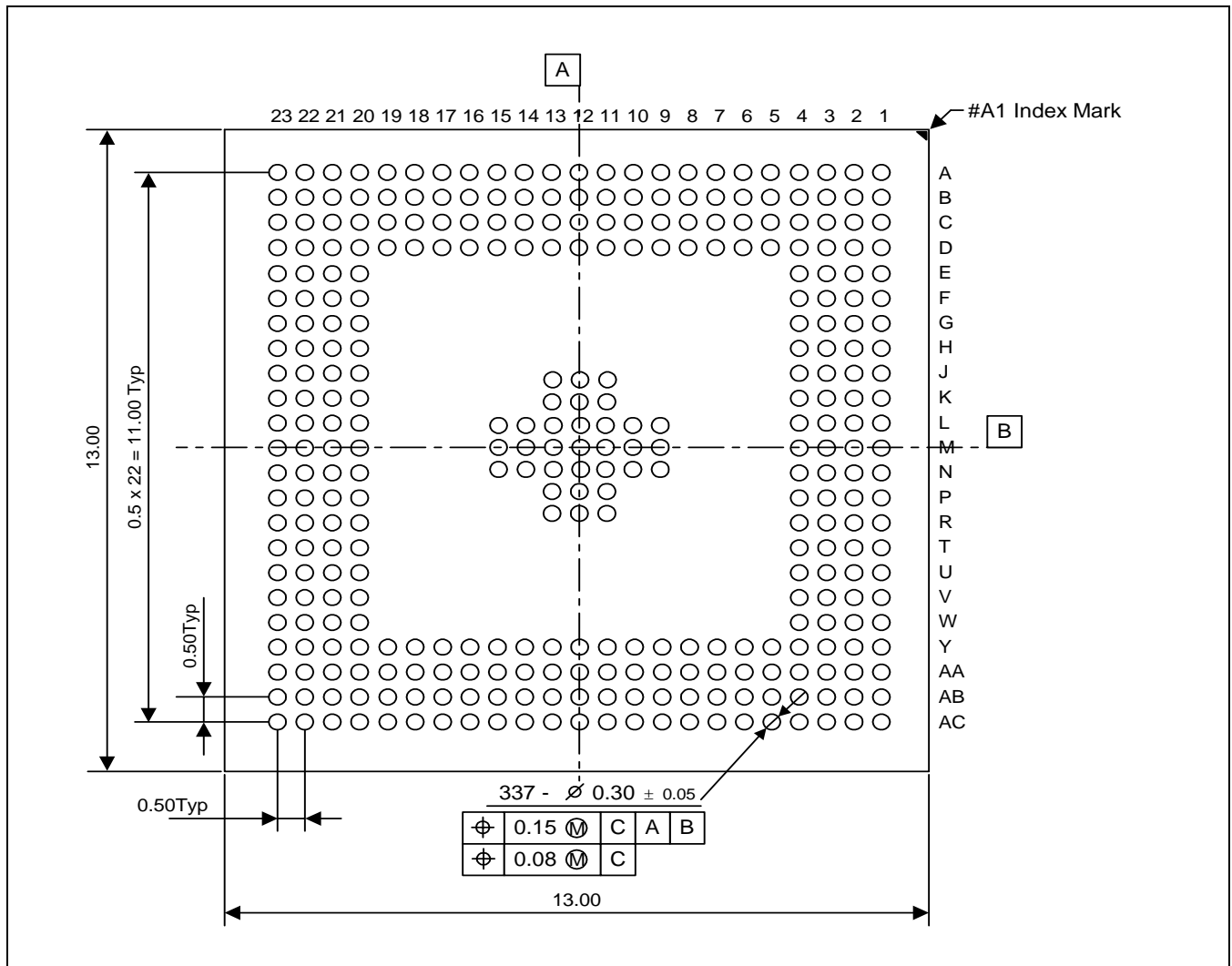

Figure 34-2. 337-FBGA-1313 Package Dimension 2 (Bottom View)