

INTRODUCTION

The S1T8603 can fulfill the standards of other countries by changing the external component. Dynamic or piezoelectric type can be used with receiver. Each gain is controlled with AGC in accordance with the line current. The S1T8603 can be operated down to D.C line 1.6V.

FEATURES

- Independent adjustment of DC resistance and AC impedance.
- ECM or dynamic microphone can be used.
- DTMF signal interface.
- Mute function
- Operates at the low line voltage (1.6V)
- Low or high impedance receiver type can be used.
- Low line current operation. ($I_L = 4\text{mA}$)

16-DIP-300A

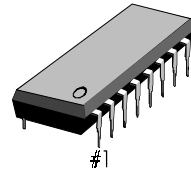

16-SOP-225

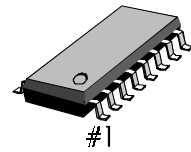

ORDERING INFORMATION

Device	Package	Operating Temperature
S1T8603X01-D0B0	16-DIP-300A	- 25°C to +75°C
S1T8603X01-S0B0	16-SOP-225	

BLOCK DIAGRAM

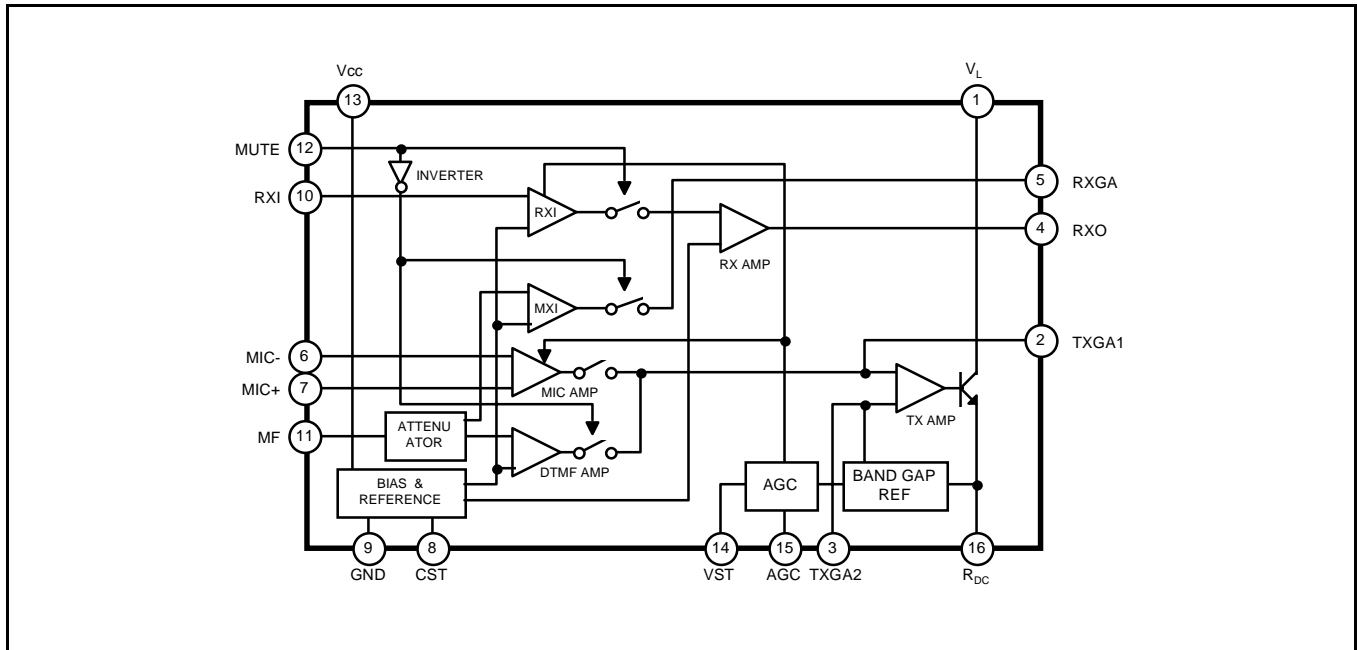

PIN CONFIGURATION

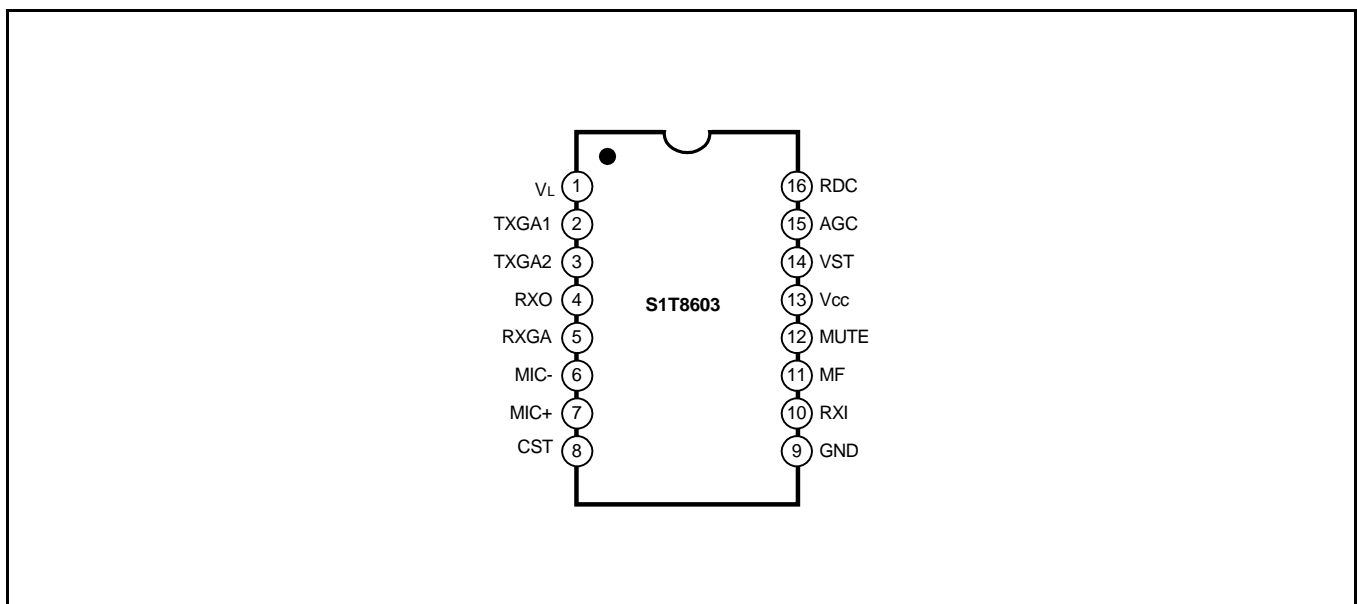

PIN DESCRIPTION

Pin No	Symbol	Description
1	V_L	Positive power line and TX Amp output
2	TXGA1	TX gain adjustment
3	TXGA2	TX gain adjustment
4	RXO	RX output
5	RXGA	RX gain adjustment
6	MIC-	Mic(-) input
7	MIC+	Mic(+) input
8	CST	Current stabilizer
9	GND	Ground
10	RXI	RX input
11	MF	DTMF Input
12	MUTE	Mute 'High': DTMF mode, Mute 'Low': speech mode
13	V_{CC}	Internal power supply pin
14	VST	Voltage stabilizer
15	AGC	Automatic gain control
16	R_{DC}	DC Resistance control

ABSOLUTE MAXIMUM RATINGS

Characteristic	Symbol	Value	Unit
Line Voltage	V_L	15	V
Line Current	I_L	150	mA
Surge Line Current	$I_{L(SURGE)}$	200	mA
Power Dissipation	P_D	1.0	W
Operating Temperature	T_{ORP}	- 25 to +75	°C
Storage Temperature	T_{STG}	- 55 to +150	°C

ELECTRICAL CHARACTERISTICS

(Ta = 25°C, f = 1kHz, I_L = 15mA, unless otherwise noted)

Characteristic	Symbol	Test Conditions	Min.	Typ.	Max.	Unit	
Line Voltage	V _L	I _L = 4mA	–	2.1	–	V	
		I _L = 15mA	3.55	3.9	4.25		
		I _L = 50mA	4.1	4.6	5.1		
		I _L = 140mA	–	6.45	7.0		
Line Voltage with R _{UP}	V _{LU}	Between Pin14 & Pin 16 R _{up} = 220kΩ	4.15	4.35	4.55	V	
Line Voltage with R _{DOWN}	V _{LD}	Between Pin 14& Pin 1 R _{DOWN} = 330kΩ	3.25	3.45	3.65	V	
TX Gain	G _{V(TX)}	R _{TX} = 68kΩ V _I = 3mV _{rsm}	I _L = 15mA	49.5	51.5	53.5	dB
			I _L = 50mA	45.5	47.5	49.5	
			I _L = 80mA	43.5	45.5	47.5	
TX Gain frequency response	ΔG _{TXF}	f = 300 to 3400Hz	–	± 0.2	–	dB	
TX Dynamic output voltage	V _{O(TX)}	THD = 2% THD = 10%	–	1.6	–	V _{rms}	
			1.7	2.2	–		
MIC Input Impedance	Z _{I(MIC)}	–	–	64	–	kΩ	
RX Gain	G _{V(RX)}	R _{LOAD} = 150Ω+10u	I _L = 15mA	28.5	30.5	32.5	dB
			I _L = 50mA	24.5	26.5	28.5	
			I _L = 80mA	22.5	24.5	26.5	
RX Gain frequency response	ΔG _{RXF}	f = 300 to 3400Hz	–	± 0.2	–	dB	
RX Dynamic output voltage	V _{O(RX)}	THD = 2% (R _L = 150Ω) THD = 10%	0.22	0.29	–	V _{rms}	
			0.30	0.40	–		
DTMF GAIN	G _{V(MF)}	R _{TX} = 68KΩ (MUTE = H)	23.5	25.5	27.5	dB	
DTMF Input Impedance	Z _{I(MF)}	–	–	20.7	–	kΩ	
MUTE Input Voltage	V _{IH(MUTE)}	–	1.5	–	V _{CC}	V	
	V _{IL(MUTE)}	–	–	–	0.8		
TX Gain variation range by AGC	ΔG _{TXA}	R _{AGC} = 180KΩ I _L = 15 ~ 80mA	–	–6	–	dB	
RX Gain variation range by AGC	ΔG _{RXA}	R _{AGC} = 180KΩ I _L = 15 ~ 80mA	–	–6	–	dB	
TX Noise Output Voltage (Psophometric weighted)	V _{TNO}	–	–	–72	–	dBmp	
RX Noise Output Voltage (Psophometric weighted)	V _{RNO}	–	–	50	–	uV	

APPLICATION CIRCUIT

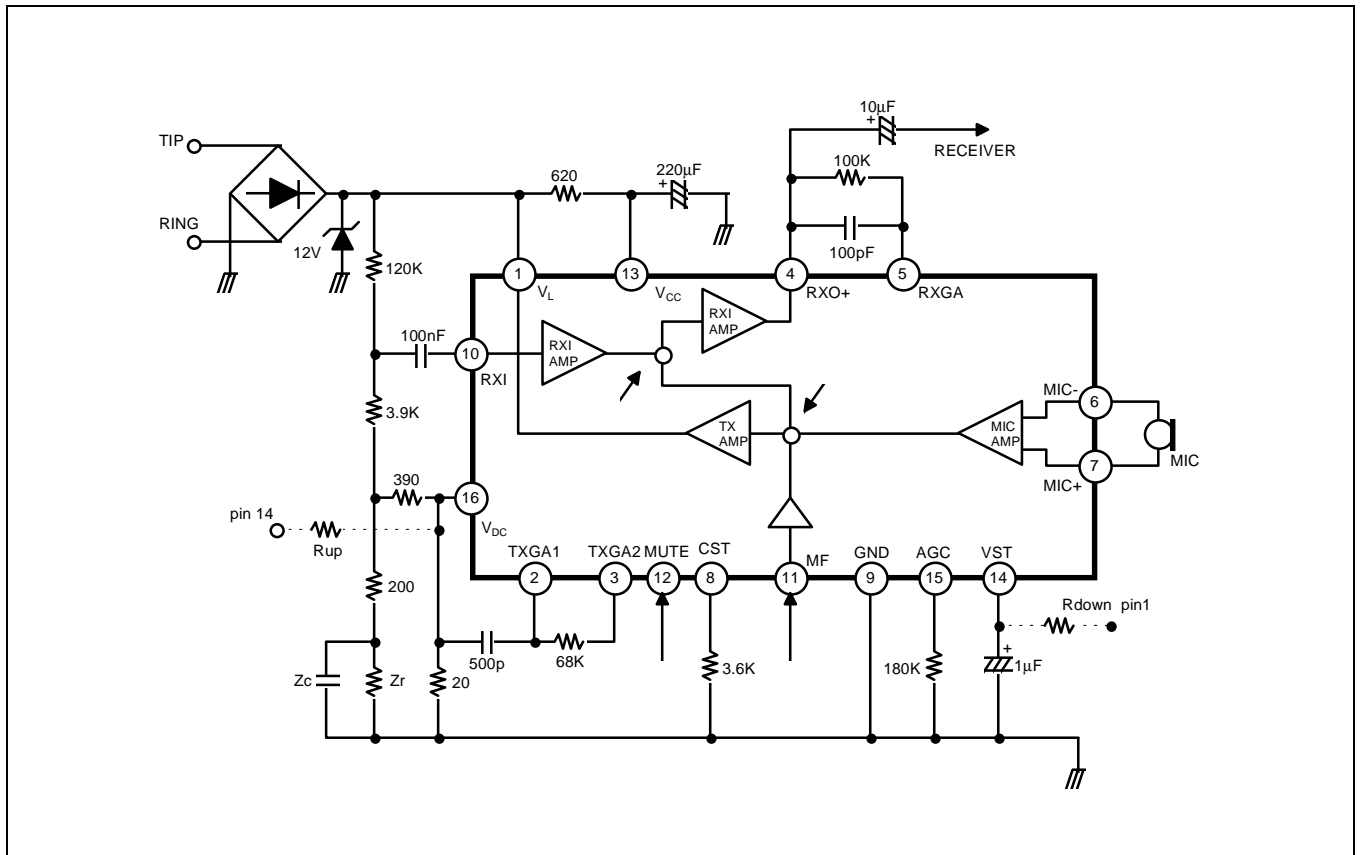

NOTES