

N-CHANNEL GaAs MESFET NES1823P-100

100W L-BAND PUSH-PULL POWER GaAs MESFET

DESCRIPTION

The NES1823P-100 is a 100 W push-pull type GaAs MESFET designed for high power transmitter applications for IMT-2000 and PCS/PCN base station systems. It is capable of delivering 100 watts of output power with high linear gain, high efficiency and excellent distortion. Its primary band is 1.8 to 2.3 GHz with different matching.

The device employs Tungsten Silicide gates, via holes, plated heat sink, and silicon dioxide and nitride passivation for superior performance, thermal characteristics, and reliability.

Reliability and performance uniformity are assured by NEC's stringent quality and control procedures.

FEATURES

- Push-pull type N-channel GaAs MESFET
- High Output Power : 100 W TYP.
- High Linear Gain : 11.0 dB TYP.
- High Drain Efficiency: 50 % TYP. @ $V_{DS} = 10$ V, $I_{Dset} = 6$ A, $f = 2.2$ GHz

ORDERING INFORMATION (PLAN)

Part Number	Package	Supplying Form
NES1823P-100	T-92	ESD protective envelope

Remark To order evaluation samples, please contact your local NEC sales office.

(Part number for sample order: NES1823P-100)

ABSOLUTE MAXIMUM RATINGS ($T_A = +25^\circ\text{C}$)

Operation in excess of any one of these parameters may result in permanent damage.

Parameter	Symbol	Ratings	Unit
Drain to Source Voltage	V_{DS}	15	V
Gate to Source Voltage	V_{GSO}	-7	V
Drain Current	I_D	76	A
Gate Current	I_G	440	mA
Total Power Dissipation	P_T	220 ^{Note}	W
Channel Temperature	T_{ch}	175	$^\circ\text{C}$
Storage Temperature	T_{stg}	-65 to +175	$^\circ\text{C}$

Note $T_C = 25^\circ\text{C}$

Caution Please handle this device at static-free workstation, because this is an electrostatic sensitive device.

The information in this document is subject to change without notice.

RECOMMENDED OPERATING LIMITS

Parameter	Symbol	Test Condition	MIN.	TYP.	MAX.	Unit
Drain to Source Voltage	V_{DS}			10.0	10.0	V
Gain Compression	G_{comp}				3.0	dB
Channel Temperature	T_{ch}				+150	°C
Set Drain Current ^{Note 1}	I_{Dset}			6.0	8.0	A
Gate Resistance ^{Note 2}	R_g			10	12.5	Ω

- Notes**
- $I_{Dset} = 3.0$ A each drain, $V_{DS} = 10$ V, RF OFF.
 - R_g is the series resistance between the gate supply and FET gate.

ELECTRICAL CHARACTERISTICS ($T_A = +25^\circ\text{C}$)

Parameter	Symbol	Test Conditions	MIN.	TYP.	MAX.	Unit
Saturated Drain Current	I_{DSS}	$V_{DS} = 2.5$ V, $V_{GS} = 0$ V		76		A
Pinch-off Voltage	V_p	$V_{DS} = 2.5$ V, $I_{DS} = 330$ mA	-4.0	-2.6		V
Thermal Resistance	R_{th}	Channel to Case		0.6	0.8	°C/W
Output Power	P_{out}	$f = 2.2$ GHz, $V_{DS} = 10$ V	49.0	50.0		dBm
Drain Current	I_D	$P_{in} = +42.5$ dBm, $R_g = 12.5$ Ω $I_{Dset} = 6.0$ A Total (RF OFF) ^{Note}		20.0	32.5	A
Drain Efficiency	η_D			50		%
Linear Gain	G_L		9.0	11.0		dB

Note $I_{Dset} = 3.0$ A each drain

TYPICAL CHARACTERISTICS ($T_A = +25^\circ\text{C}$)
POWER MATCHING AND IM_3 MATCHING

NEC produces two type matching circuits, power matching and IM_3 matching. Power matching circuit is used our production line. And the IM_3 matching circuit is useful for the customers to design the special tuning application. The power matching is designed as this, input impedance is gain-matching, output is matched with power matching impedance which is calculated with large signal simulation model. The IM_3 matching is designed as this, input impedance is matched to the impedance which has the direction of decreasing S_{21} phase-shift, output impedance is matched to the almost same as the efficiency matching impedance. Those typical RF data are shown as this, $G_L = 10.2$ dB $P_{\text{out}} = 50.0$ dBm $\text{IM}_3 = -28$ dBc at power matching, $G_L = 10.0$ dB $P_{\text{out}} = 49.3$ dBm $\text{IM}_3 = -31$ dBc at IM_3 matching (@2 tone $P_{\text{out}} = 40$ dBm).

POWER MATCHING
 OUTPUT POWER, DRAIN CURRENT AND EFFICIENCY
 vs. INPUT POWER

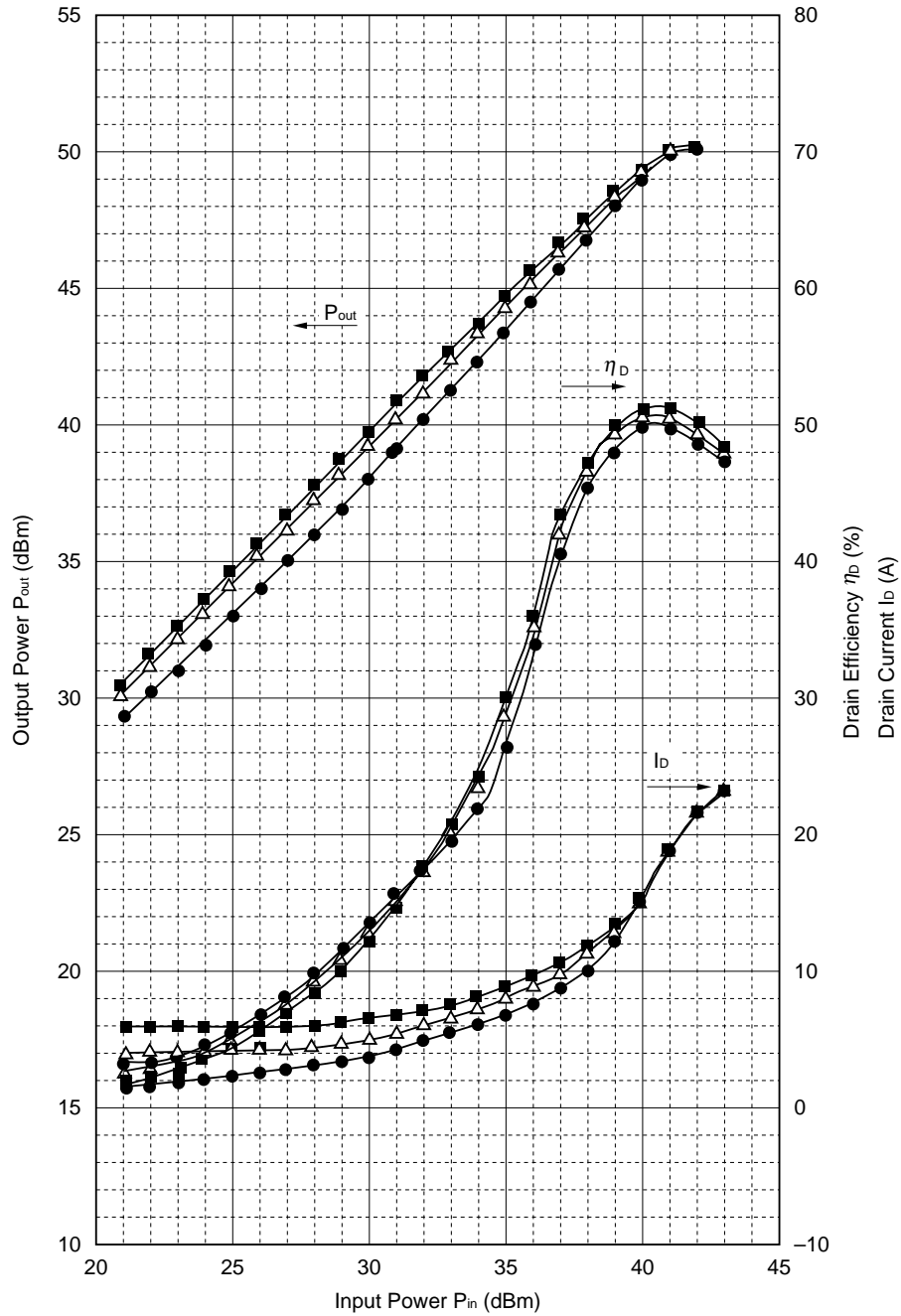

$V_{DS} = 10$ V
 $f = 2.2$ GHz
 $R_g = 12.5 \Omega$
 ● $I_{Dset} = 2$ A
 △ $I_{Dset} = 4$ A
 ■ $I_{Dset} = 6$ A

DISTORTION MATCHING
 OUTPUT POWER, DRAIN CURRENT AND EFFICIENCY
 vs. INPUT POWER

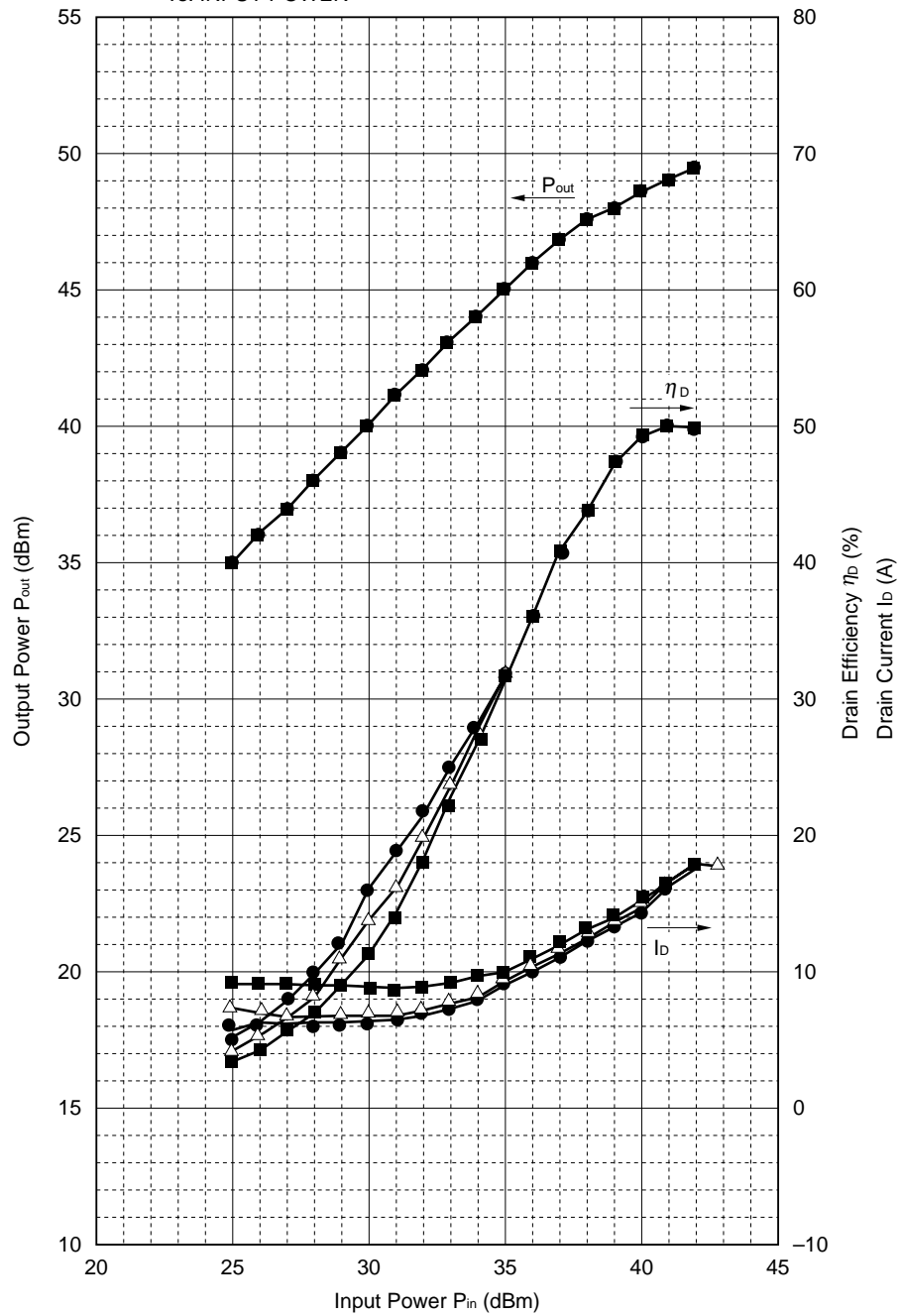

$V_{DS} = 10\text{ V}$
 $f = 2.12\text{ GHz}$
 $R_g = 12.5\ \Omega$
 ● $I_{Dset} = 6\text{ A}$
 △ $I_{Dset} = 8\text{ A}$
 ■ $I_{Dset} = 10\text{ A}$

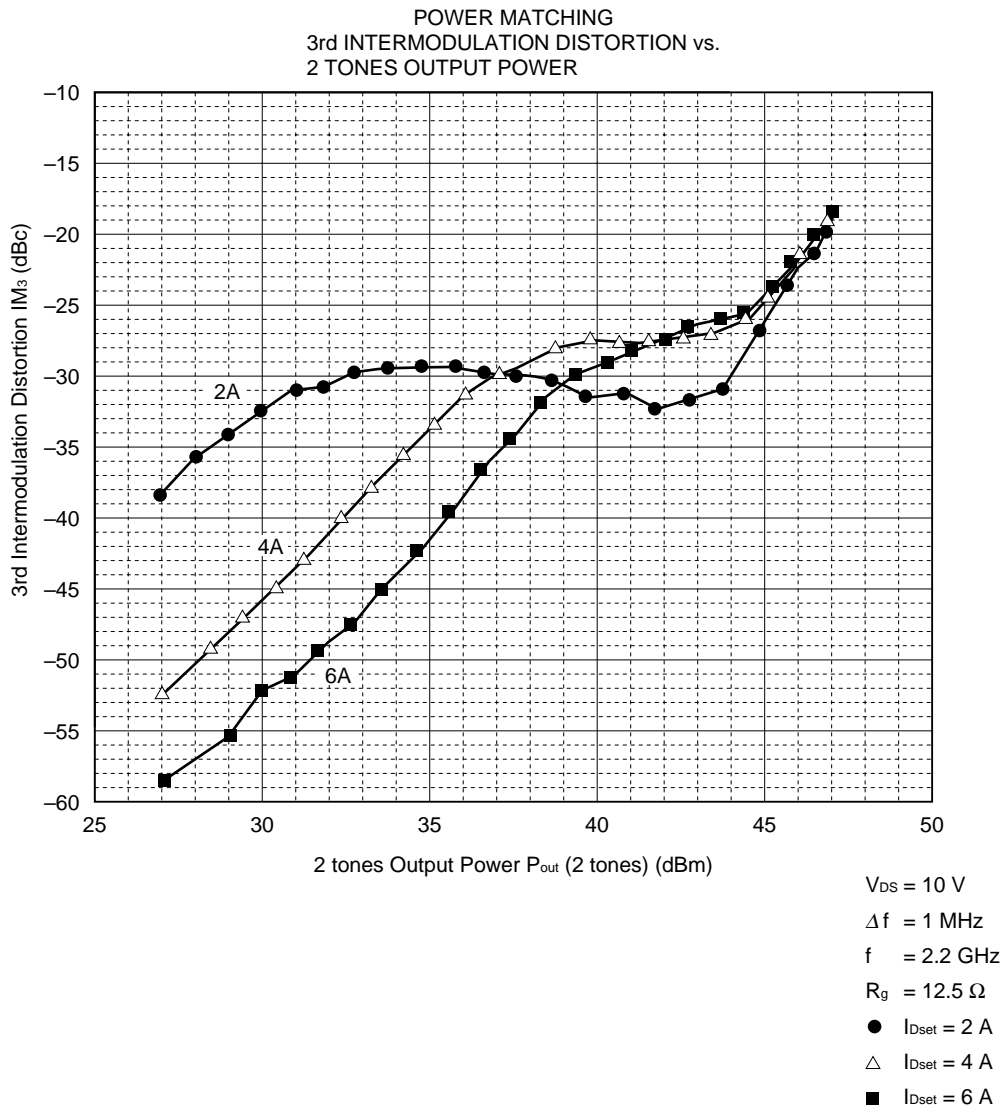

DISTORTION MATCHING
3rd INTER MODULATION DISTORTION vs.
2TONES OUTPUT POWER

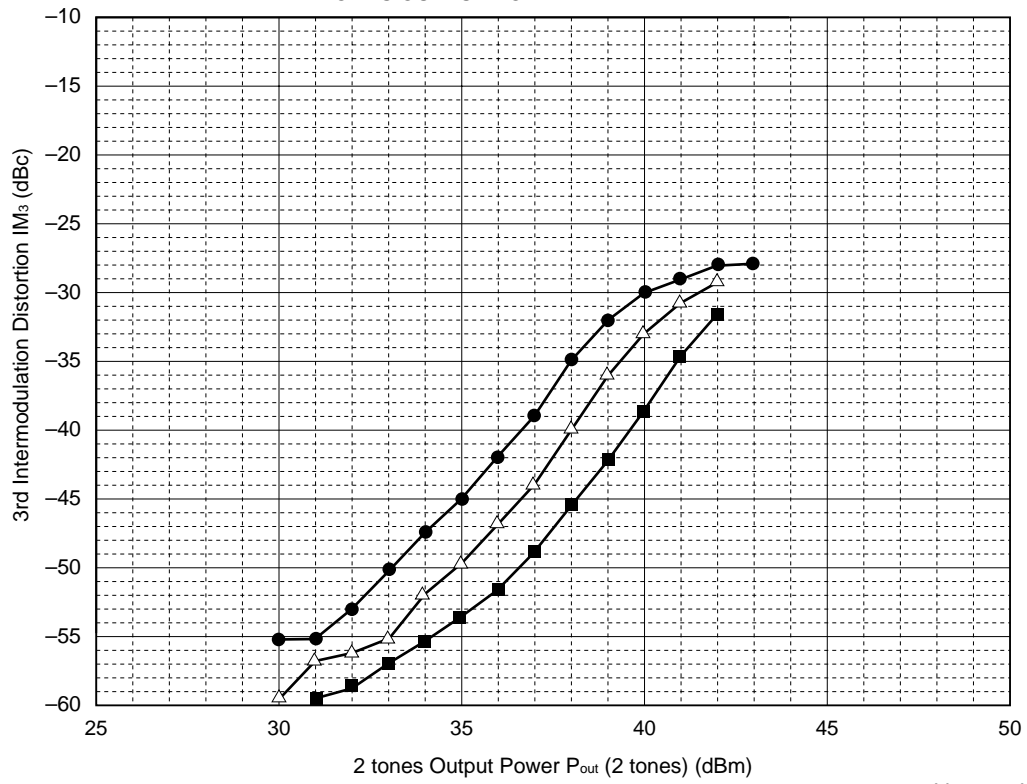

V_{DS} = 10 V
Δf = 1 MHz
f = 2.12 GHz
R_g = 12.5 Ω
● Idset = 6 A
△ Idset = 8 A
■ Idset = 10 A

DISTORTION MATCHING
 3rd INTER MODULATION DISTORTION vs.
 2TONES OUTPUT POWER

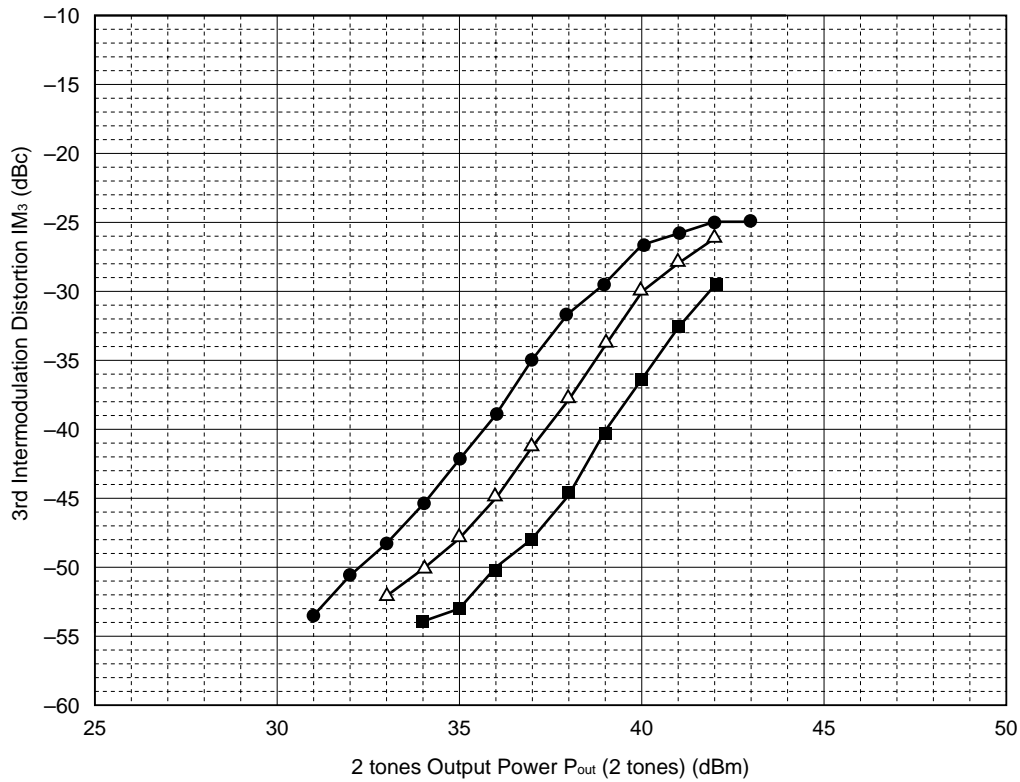

V_{DS} = 10 V
 Δf = 20 MHz
 f = 2.12 GHz
 R_g = 12.5 Ω
 ● I_{Dset} = 6 A
 △ I_{Dset} = 8 A
 ■ I_{Dset} = 10 A

S-Parameters

$V_{DS} = 10\text{ V}$, $I_{Dset} = 3\text{ A}$ each drain

START 1 GHz, STOP 3 GHz, STEP 40 MHz

Marker 2.2 GHz

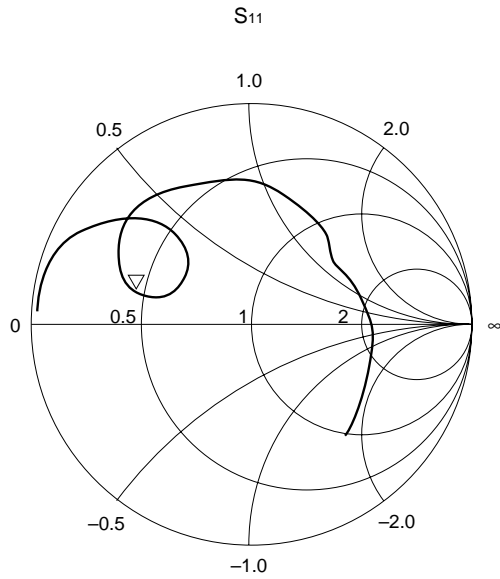

$R_{max.} = 1$

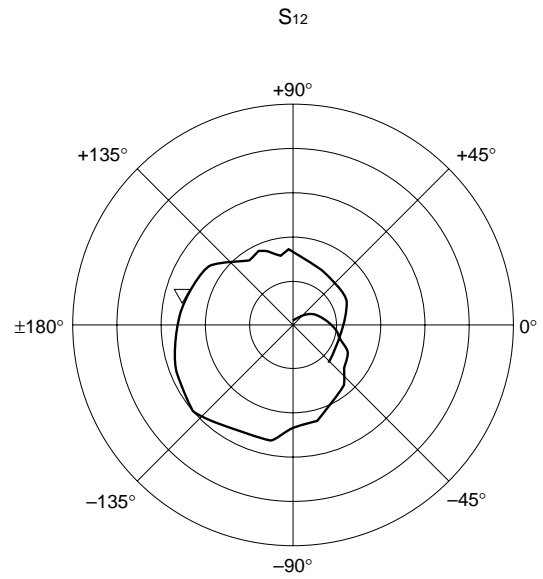

$R_{max.} = 0.1$

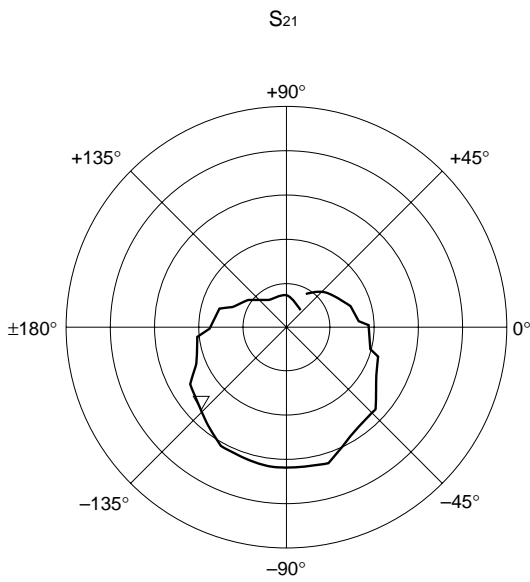

$R_{max.} = 5$

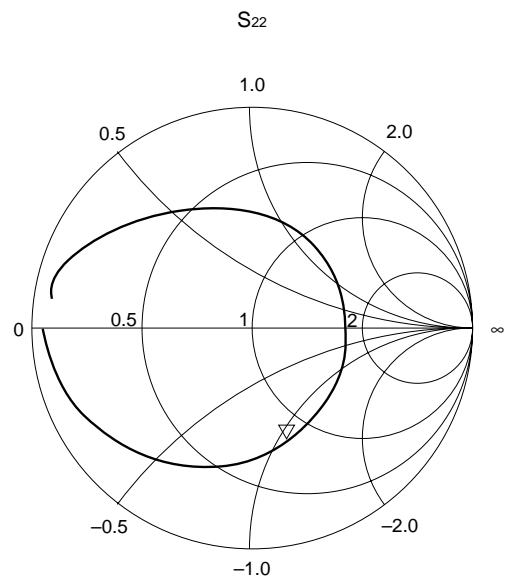

$R_{max.} = 1$

S-Parameters

$V_{DS} = 10\text{ V}$, $I_{Dset} = 3\text{ A}$ each drain

FREQUENCY GHz	S ₁₁		S ₂₁		S ₁₂		S ₂₂	
	MAG.	ANG.	MAG.	ANG.	MAG.	ANG.	MAG.	ANG.
1.000	0.959	173.5	0.857	65.1	0.006	62.5	0.943	171.2
1.040	0.959	172.7	0.537	58.8	0.006	57.4	0.924	166.7
1.080	0.956	171.7	0.478	57.7	0.006	53.7	0.922	165.7
1.120	0.956	170.8	0.429	58.5	0.007	51.0	0.914	164.2
1.160	0.956	170.8	0.419	59.5	0.007	48.3	0.904	162.7
1.200	0.950	168.7	0.408	62.7	0.008	47.1	0.898	161.5
1.240	0.946	167.5	0.424	60.9	0.008	43.5	0.880	159.8
1.280	0.941	166.2	0.416	66.8	0.009	43.8	0.866	158.2
1.320	0.941	164.8	0.475	68.3	0.009	37.8	0.851	156.4
1.360	0.935	163.3	0.540	68.3	0.010	34.8	0.832	154.7
1.400	0.927	161.7	0.577	67.2	0.012	32.1	0.814	152.8
1.440	0.920	159.9	0.728	66.4	0.012	28.6	0.794	150.9
1.480	0.912	158.1	0.780	59.2	0.014	20.2	0.776	148.9
1.520	0.903	156.0	0.956	55.2	0.015	18.9	0.758	146.8
1.560	0.890	153.9	1.001	46.2	0.017	9.6	0.739	144.5
1.600	0.876	151.5	1.183	41.6	0.018	7.7	0.720	142.0
1.640	0.858	149.1	1.262	30.6	0.021	-1.8	0.701	139.5
1.680	0.839	146.6	1.364	24.7	0.022	-8.4	0.683	136.7
1.720	0.815	143.8	1.542	16.7	0.025	-18.3	0.663	133.6
1.760	0.789	141.2	1.585	6.3	0.028	-25.1	0.644	130.0
1.800	0.756	138.1	1.823	3.4	0.030	-36.7	0.625	125.8
1.840	0.719	135.1	1.968	-11.4	0.036	-45.7	0.606	120.5
1.880	0.674	132.1	2.157	-16.4	0.038	-58.5	0.583	113.6
1.920	0.616	129.1	2.379	-28.8	0.044	-74.2	0.563	104.6
1.960	0.548	127.3	2.757	-40.5	0.045	-85.5	0.535	91.7
2.000	0.474	127.6	2.806	-54.6	0.054	-103.2	0.499	74.1
2.040	0.405	132.9	3.193	-70.0	0.055	-120.7	0.461	50.3
2.080	0.371	144.4	3.181	-85.4	0.059	-140.4	0.436	19.8
2.120	0.403	156.0	3.141	-103.6	0.058	-159.5	0.443	-14.0
2.160	0.477	160.5	3.069	-118.7	0.054	-179.6	0.483	-44.9
2.200	0.553	159.4	2.740	-133.2	0.051	168.1	0.543	-69.8
2.240	0.622	155.8	2.545	-150.0	0.048	147.2	0.605	-89.0
2.280	0.664	150.3	2.246	-157.0	0.042	135.8	0.660	-103.5
2.320	0.693	144.6	2.008	-175.7	0.036	123.9	0.708	-115.0
2.360	0.712	138.7	1.732	-178.2	0.038	114.5	0.749	-124.2
2.400	0.719	132.7	1.576	165.7	0.031	100.7	0.783	-131.9
2.440	0.723	127.3	1.333	161.8	0.033	94.9	0.804	-136.9
2.480	0.721	120.8	1.181	156.5	0.029	80.3	0.823	-142.7
2.520	0.713	114.1	1.131	149.7	0.028	74.3	0.848	-147.4
2.560	0.701	106.5	0.887	145.0	0.028	65.5	0.860	-151.8
2.600	0.684	98.3	0.965	142.0	0.028	46.9	0.875	-155.2
2.640	0.661	88.7	0.751	135.7	0.026	44.9	0.882	-158.4
2.680	0.632	78.0	0.851	134.8	0.027	27.6	0.894	-161.5
2.720	0.594	65.6	0.727	125.7	0.026	18.4	0.900	-163.8
2.760	0.542	51.8	0.735	119.7	0.023	3.4	0.907	-166.2
2.800	0.483	40.7	0.650	119.2	0.022	-5.7	0.915	-168.7
2.840	0.499	29.6	0.714	109.0	0.020	-7.0	0.917	-170.4
2.880	0.530	10.9	0.636	106.7	0.023	-15.0	0.923	-172.2
2.920	0.555	-9.1	0.689	94.9	0.023	-24.8	0.928	-174.0
2.960	0.587	-28.3	0.654	88.7	0.022	-36.4	0.931	-175.7
3.000	0.625	-46.2	0.625	72.9	0.024	-47.5	0.932	-177.1

CIRCUIT DESIGN

The matching circuit of package inside consists of bond-wire, chip-capacitor and microstrip line on the alumina substrate. The package-lead impedance is designed as 25Ω connecting to the external matching circuit, in the external circuit design, the microstrip line impedance is 25Ω , conjugate with package impedance, then the impedance is connected to balun, it is 1:2 balun structure, finally connected to 50Ω . Balun technology has some advantage over single-ended device, minimize matching-loss with decrease of impedance change ratio and cancel the even mode harmonic frequency for IM_3 performance. The balun circuit is employed for this product.

BALUN DESIGN

The balun design is the key for these high power push-pull structure device. NEC designed low insertion loss microstrip balun for this product. What is the reason of our choice? One is the repeatability of assembly, and the other is its performance. Microstrip balun performance tolerance is small because of its simple structure. So the balun performance is stable and repeatable between NEC and customers. And its insertion loss is 0.2 dB less than coaxial balun 0.3 dB, also its band width is better than coaxial balun. The microstrip balun is consists of microstrip pattern and cavity, therefore its insertion loss and band width due to its parameter design. Those parameters are optimized with simulation. : (substrate duroid $\epsilon_r = 2.2$ $t = 0.8$ mm)

Then the phase difference between two ports is $180^\circ \pm 4$, insertion loss is 0.2 dB from 1 to 3 GHz.

DC STABILITY (AVOID OSCILLATION)

The function of DC-cut capacitor arranged between transformer and microstrip balun is avoid DC oscillation. When the gate is pinch-off, a few pinch-off voltage (VP) difference of each port occur the loop current, then start DC oscillation in the area of pinch-off. Because of this reasons, the DC-cut capacitor is need to this microstrip balun assemble. Additionally, the ground of transformer substrate is effective to DC oscillation, so that five screws are arranged at the middle of substrate.

RF TEST FIXTURE

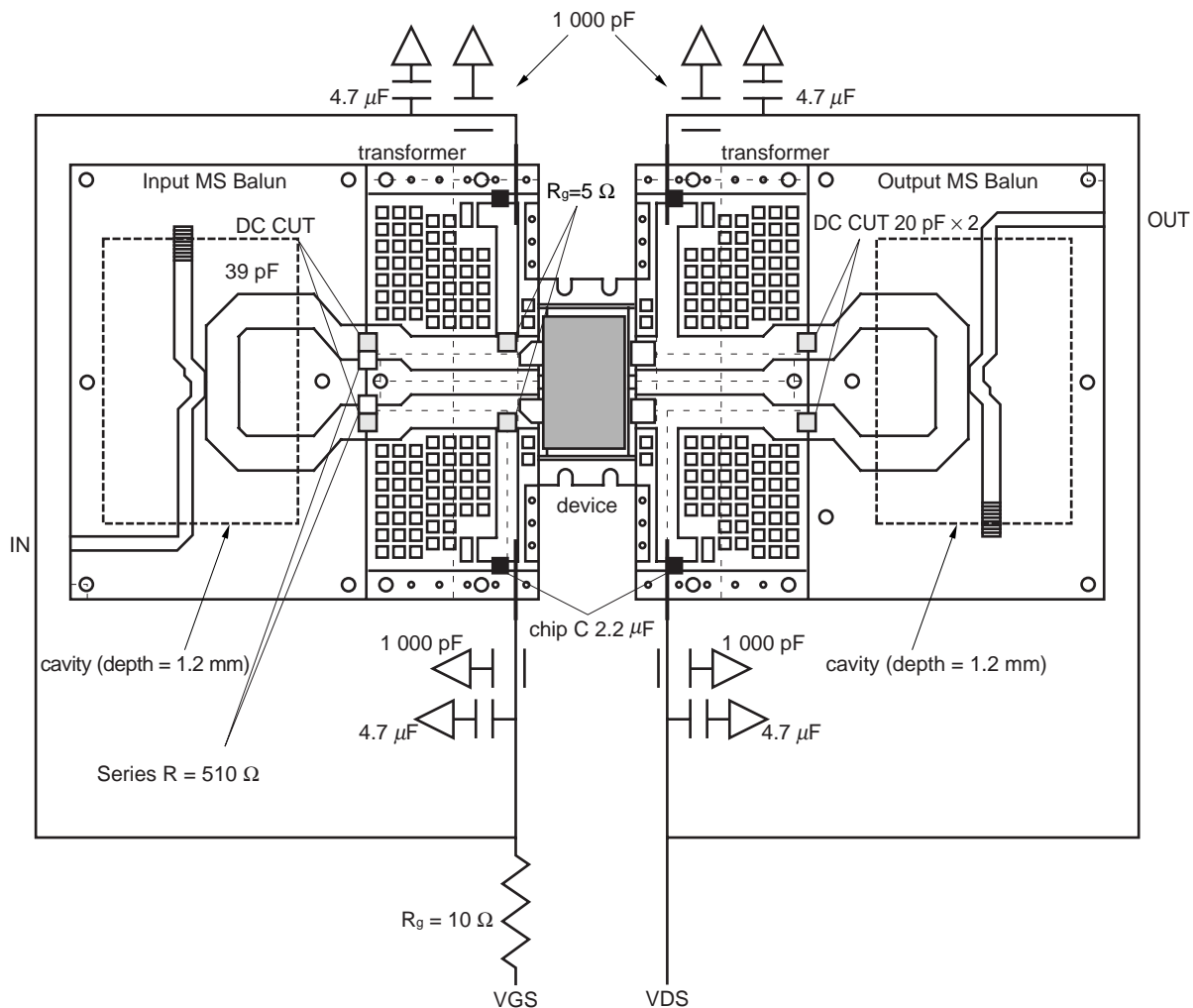
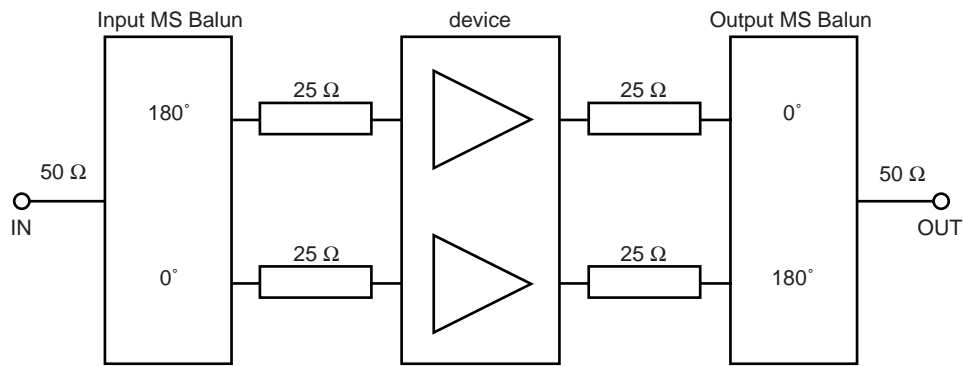

FIGURES OF SUBSTRATE (UNIT: mm)
BALUN (FACE)

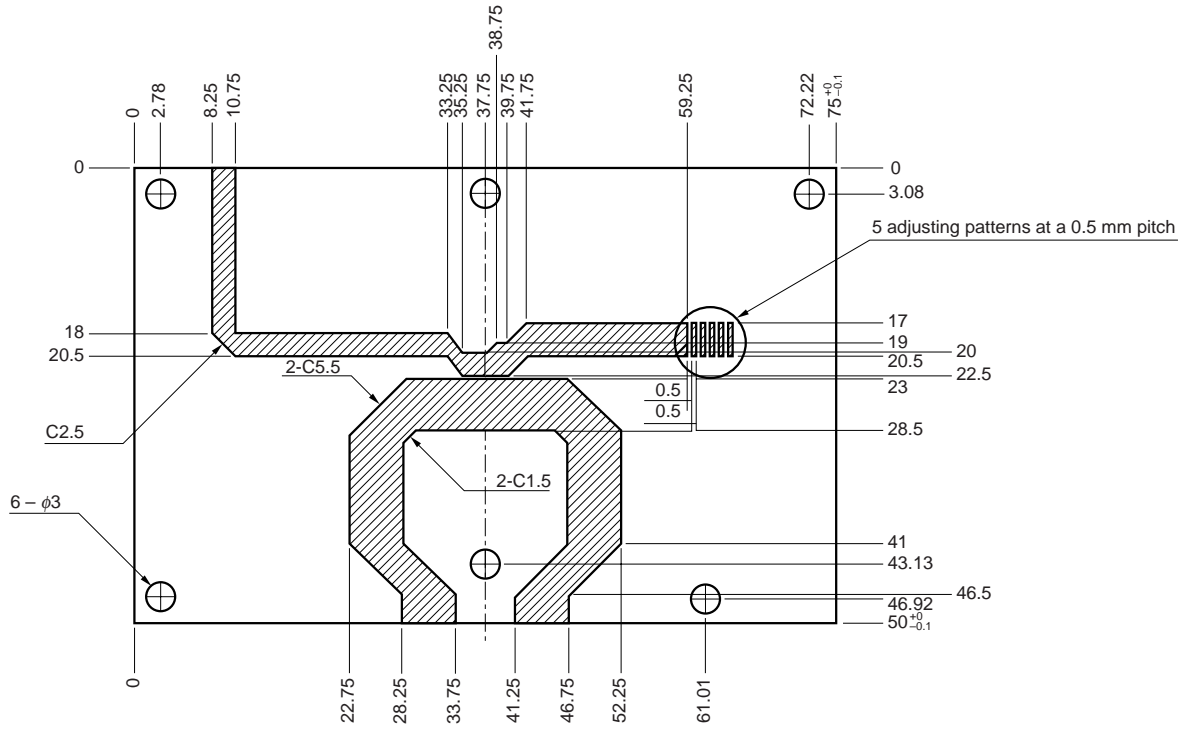

BALUN (BACK)

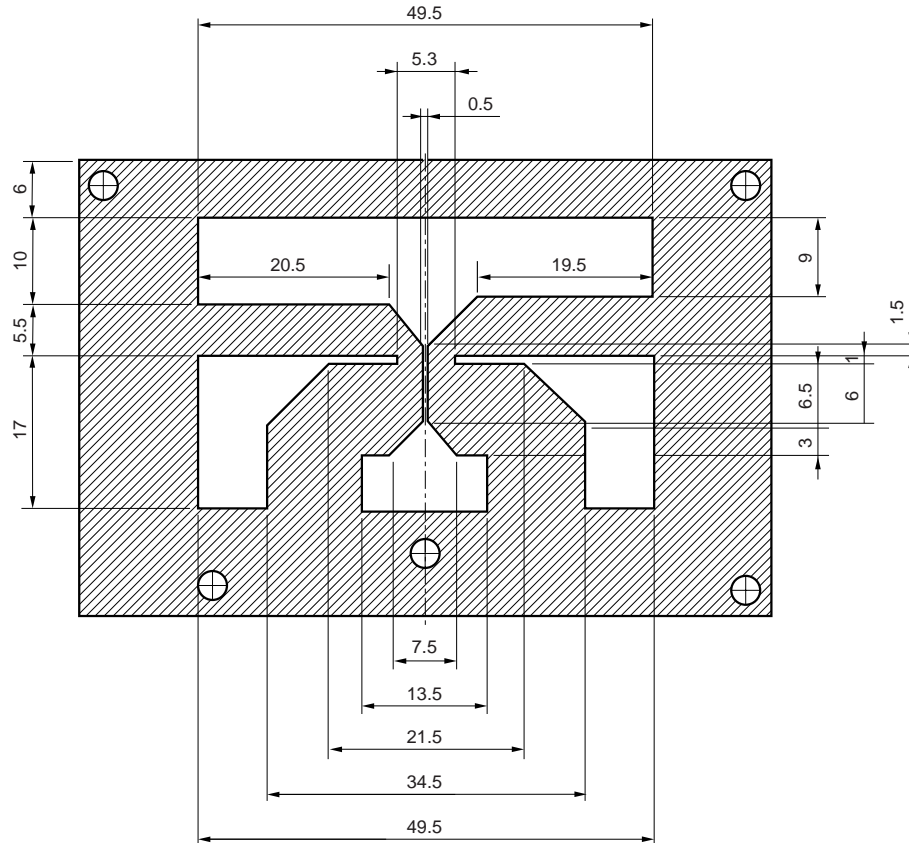

PACKAGE DIMENSIONS (UNIT: mm)

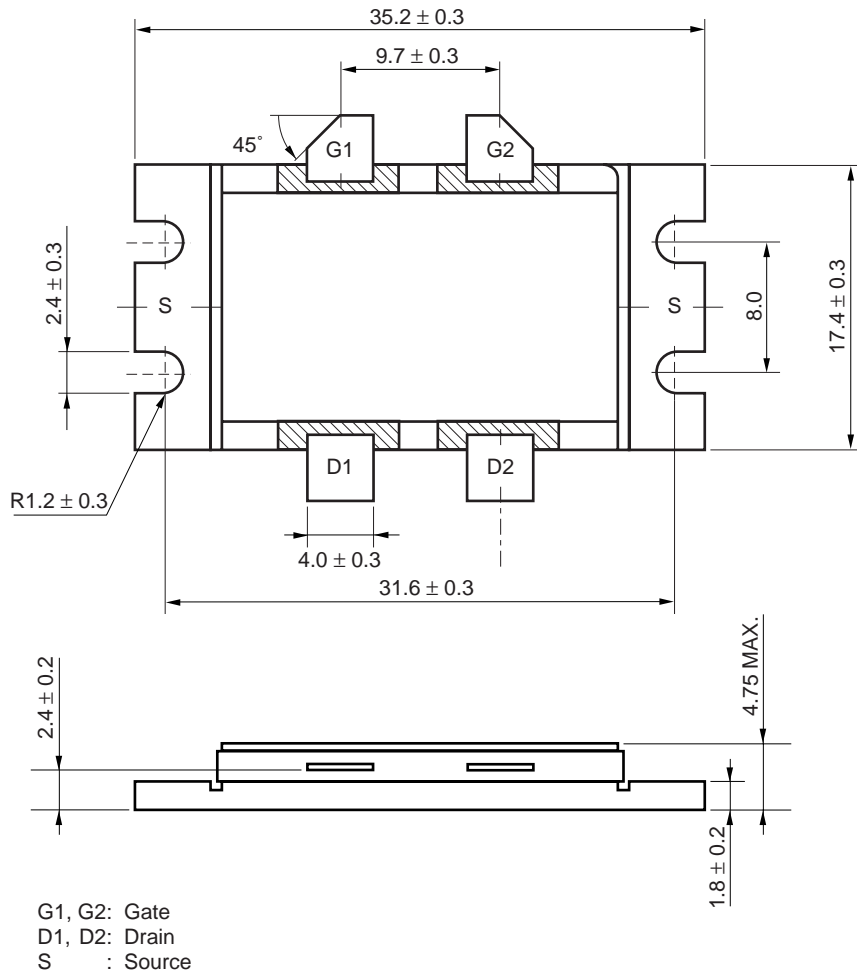

RECOMMENDED MOUNTING CONDITION FOR CORRECT USE

- (1) Fix to a heatsink or mount surface completely with screw at the four holes of the flange.
- (2) Recommended torque strength of the screw is 3 kgF typical using M2.3 type screw.
- (3) Recommended flatness of the mount surface is less than $\pm 10 \mu\text{m}$. (roughness of surface is $\nabla\nabla\nabla$)

RECOMMENDED SOLDERING CONDITIONS

This product should be soldered under the following recommended conditions. For soldering methods and conditions other than those recommended below, contact your NEC sales representative.

Soldering Method	Soldering Conditions	Recommended Condition Symbol
Partial Heating	Pin temperature: 260°C Time: 5 seconds or less (per pin row)	—

For details of recommended soldering conditions, please contact your local NEC sales office.

[MEMO]

[MEMO]

[MEMO]

Caution

**The Great Care must be taken in dealing with the devices in this guide.
The reason is that the material of the devices is GaAs (Gallium Arsenide), which is designated as harmful substance according to the law concerned.
Keep the law concerned and so on, especially in case of removal.**

No part of this document may be copied or reproduced in any form or by any means without the prior written consent of NEC Corporation. NEC Corporation assumes no responsibility for any errors which may appear in this document.

NEC Corporation does not assume any liability for infringement of patents, copyrights or other intellectual property rights of third parties by or arising from use of a device described herein or any other liability arising from use of such device. No license, either express, implied or otherwise, is granted under any patents, copyrights or other intellectual property rights of NEC Corporation or others.

While NEC Corporation has been making continuous effort to enhance the reliability of its semiconductor devices, the possibility of defects cannot be eliminated entirely. To minimize risks of damage or injury to persons or property arising from a defect in an NEC semiconductor device, customers must incorporate sufficient safety measures in its design, such as redundancy, fire-containment, and anti-failure features.

NEC devices are classified into the following three quality grades:

"Standard", "Special", and "Specific". The Specific quality grade applies only to devices developed based on a customer designated "quality assurance program" for a specific application. The recommended applications of a device depend on its quality grade, as indicated below. Customers must check the quality grade of each device before using it in a particular application.

Standard: Computers, office equipment, communications equipment, test and measurement equipment, audio and visual equipment, home electronic appliances, machine tools, personal electronic equipment and industrial robots

Special: Transportation equipment (automobiles, trains, ships, etc.), traffic control systems, anti-disaster systems, anti-crime systems, safety equipment and medical equipment (not specifically designed for life support)

Specific: Aircrafts, aerospace equipment, submersible repeaters, nuclear reactor control systems, life support systems or medical equipment for life support, etc.

The quality grade of NEC devices is "Standard" unless otherwise specified in NEC's Data Sheets or Data Books. If customers intend to use NEC devices for applications other than those specified for Standard quality grade, they should contact an NEC sales representative in advance.

Anti-radioactive design is not implemented in this product.