

### GENERAL DESCRIPTION

The AK4113 is a 24-bit stereo digital audio receiver that supports sampling rates up to 216kHz. The channel status bits decoder supports both consumer and professional modes. The AK4113 automatically detects non-PCM bit streams such as Dolby Digital, MPEG etc. When combined with the multi channel codec (AK4626 or AK4628), the two chips provide a system solution for Dolby Digital applications. Control of AK4113 is achieved through a  $\mu$ P or pin strapping (parallel mode). It is packaged in a space-saving 30-pin VSOP.

\* Dolby Digital is a trademark of Dolby Laboratories.

### FEATURES

- AES/EBU, IEC60958, S/PDIF, EIAJ CP1201 Compatible
- Low Jitter Analog PLL
- PLL Lock Range: 8k ~ 216kHz
- Clock source: PLL or X'tal
- 6-channel Receiver Input and 1-channel Transmission Output (Through output)
- Auxiliary Digital Input
- De-emphasis for 32kHz, 44.1kHz and 48kHz
- Detection Functions
  - Non-PCM Bit Stream Detection
  - DTS-CD Bit Stream Detection
  - Sampling Frequency Detection  
(8kHz, 11.025kHz, 16kHz, 22.05kHz, 24kHz, 32kHz, 44.1kHz, 48kHz, 64kHz, 88.2kHz, 96kHz, 176.4kHz and 192kHz)
  - Unlock & Parity Error Detection
  - Validity Detection
  - DAT Start ID Detection
- Up to 24bit Audio Data Format
- Audio Interface: Master or Slave Mode
- 40-bit Channel Status Buffer
- Burst Preamble bit Pc and Pd Buffer for Non-PCM bit stream
- Q-subcode Buffer for CD bit stream
- Serial  $\mu$ P Interface: I<sup>2</sup>C (max. 400kHz) or 4-wire
- Two Master Clock Outputs: 64fs/128fs/256fs/512fs
- Operating Voltage: 2.7 to 3.6V with 5V Logic Tolerance
- Small Package: 30pin VSOP
- Ta: - 40 ~ 85°C

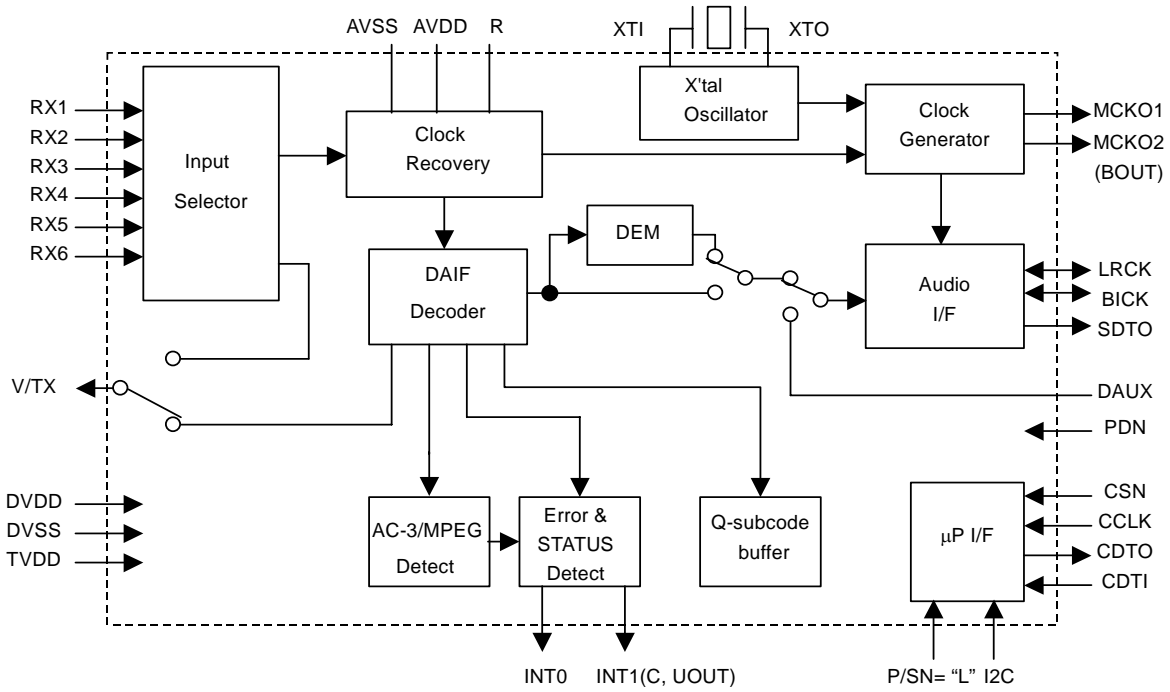

Figure 1. Serial control mode

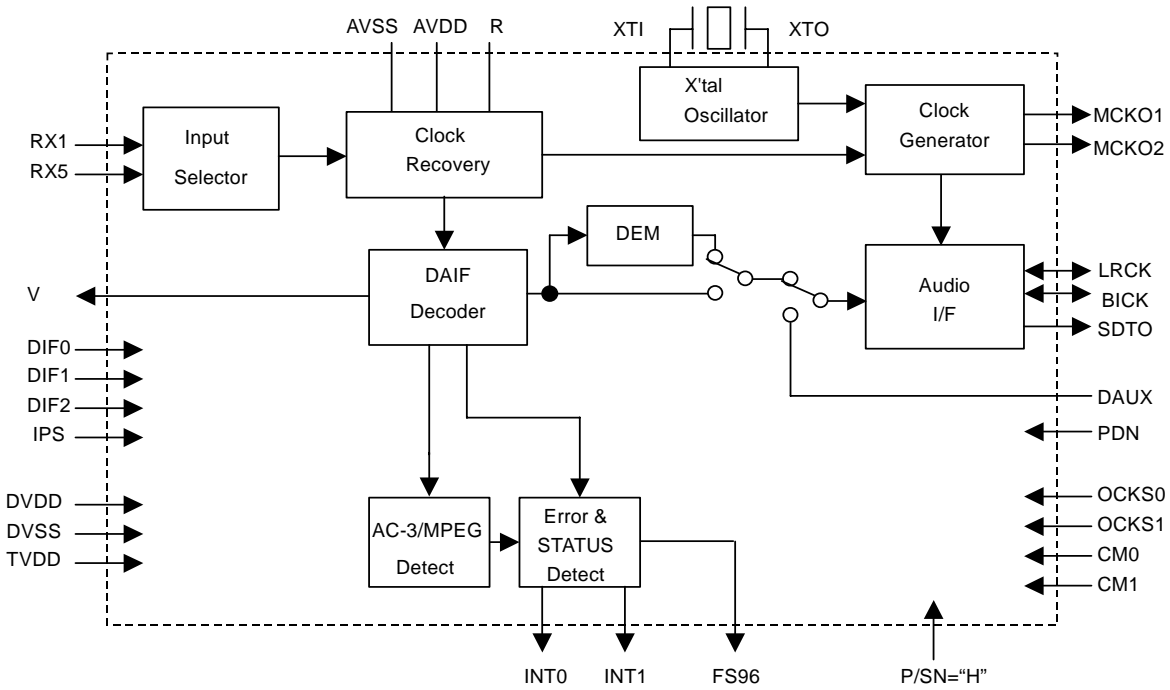
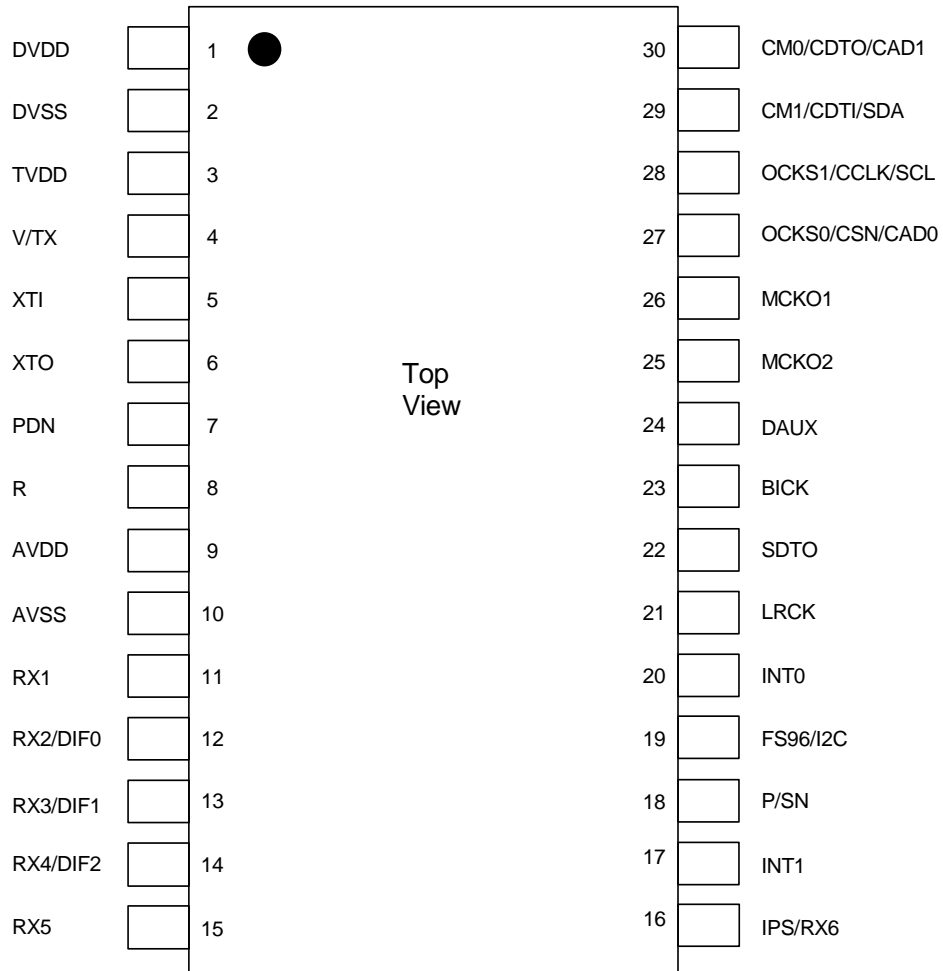

Figure 2. Parallel control mode

■ Ordering Guide

AK4113VF    -40 ~ +85 °C    30pin VSOP (0.65mm pitch)  
 AKD4113    Evaluation board for AK4113

■ PIN Layout



PIN/FUNCTION			
No.	Pin Name	I/O	Function
1	DVDD	-	Digital Power Supply Pin, 3.3V
2	DVSS	-	Digital Ground Pin
3	TVDD	-	Input Buffer Power Supply Pin, 3.3V or 5V
4	V	O	Validity Flag Output Pin in Parallel control mode
	TX	O	Transmit channel (Through data) Output Pin in serial control mode
5	XTI	I	X'tal Input Pin
6	XTO	O	X'tal Output Pin
7	PDN	I	Power-Down Mode Pin When "L", the AK4113 is powered-down and reset.
8	R	-	External Resistor Pin This pin must be connected to AVSS via 15kΩ ±5% resistor.
9	AVDD	-	Analog Power Supply Pin
10	AVSS	-	Analog Ground Pin
11	RX1	I	Receiver Channel #1 Pin (Internal Biased Pin)
12	DIF0	I	Audio Data Interface Format #0 Pin in parallel control mode
	RX2	I	Receiver Channel #2 Pin in serial control mode (Internal Biased Pin)
13	DIF1	I	Audio Data Interface Format #1 Pin in parallel control mode
	RX3	I	Receiver Channel #3 Pin in serial control mode (Internal Biased Pin)
14	DIF2	I	Audio Data Interface Format #2 Pin in parallel control mode
	RX4	I	Receiver Channel #4 Pin in serial control mode (Internal Biased Pin)
15	RX5	I	Receiver Channel #5 Pin (Internal Biased Pin)
16	IPS	I	Input Channel Select Pin in parallel control mode
	RX6	I	Receiver Channel #6 Pin (Internal Biased Pin)
17	INT1	O	Interrupt #1 Pin (when BCU bit = "0")
			U-bit Output Pin (when BCU bit = "1", UCE bit = "0")
			C-bit Output Pin (when BCU bit = "1", UCE bit = "1")
18	P/SN	I	Parallel/Serial Select Pin "L": Serial control mode, "H": Parallel control mode
19	FS96	O	96kHz Sampling Detect Pin in parallel control mode This function is enabled when the input frequency of XTI is 24.576MHz. "L": fs=54kHz or less, "H": fs=64kHz or more
	I2C	I	I <sup>2</sup> C Select Pin in Serial control mode. "L": 4-wire Serial, "H": I <sup>2</sup> C
20	INT0	I	Interrupt #0 Pin
21	LRCK	I/O	Output Channel Clock Pin
22	SDTO	O	Audio Serial Data Output Pin
23	BICK	I/O	Audio Serial Data Clock Pin
24	DAUX	I	Auxiliary Audio Data Input Pin
25	MCKO2	O	Master Clock #2 Output Pin (when BCU bit = "0")
			Block Start Signal Output Pin (when BCU bit = "1")
26	MCKO1	O	Master Clock #1 Output Pin
27	OCKS0	I	Output Clock Select #0 Pin in parallel control mode
	CSN	I	Chip Select Pin in serial control mode, I2C pin = "L"
	CAD0	I	Chip Address #0 Pin in serial control mode, I2C pin = "H"

Note 1. Do not allow digital input pins except internal biased pins (RX1-6 pins) to float.

No.	Pin Name	I/O	Function
28	OCKS1	I	Output Clock Select #1 Pin in parallel control mode
	CCLK	I	Control Data Clock Pin in serial control mode, I2C pin = "L"
	SCL	I	Control Data Clock Pin in serial control mode, I2C pin = "H"
29	CM1	I	Master Clock Operation Mode #1 Pin in parallel control mode
	CDTI	I	Control Data Input Pin in serial control mode, I2C pin = "L"
	SDA	I/O	Control Data Pin in serial control mode, I2C pin = "H"
30	CM0	I	Master Clock Operation Mode #0 Pin in parallel control mode
	CDTO	O	Control Data Output Pin in serial control mode
	CAD1	I	Chip Address #1 Pin in serial control mode, I2C pin = "H"

Note 1. Do not allow digital input pins except internal biased pins (RX1-6 pins) to float.

### ■ Handling of Unused Pin

The unused I/O pin should be processed appropriately as below.

Classification	Pin Name	Setting
Analog Input	RX1, RX2/DIF0, RX3/DIF1, RX4/DIF2, RX5, RX6/IPS	These pins should be open in serial control mode.
	RX1, RX5	These pins should be open in parallel control mode.
Digital Input	DAUX, XTI	These pins should be connected to DVSS.
Digital Output	V/TX, XTO, INT0, INT1, MCKO1, MCKO2	These pins should be open.
	I2C/FS96	This pin should be open in parallel control mode.
	CAD1/CDTO/CM0	This pin should be open in serial control mode and 4-wire mode (I2C pin = "L").

## ■ Compare AK4112B with AK4113

### 1. Function

Function		AK4112B	AK4113
RX Input Channel	Serial control mode	4ch	6ch
	Parallel control mode	1ch	2ch
PLL Lock Range		22kHz to 108kHz	8kHz to 216kHz
Resistor value for R pin		18k ± 1%	15k ± 5%
PLL Lock Time		≤ 20ms	FAST bit = "0": ≤ (15ms+384/fs) FAST bit = "1": ≤ (15ms+1/fs)
DTS-CD Bit Stream Detection		Not available	Available
DAT Start ID Detection		Not available	Available
Q-subcode Buffer for CD bit Stream		Not available	Available
fs Detection in serial control mode		≤ 54kHz ≥or ≥88.2kHz	8k / 11.025k / 16k / 22.05k / 24k/ 32k / 44.1k / 48k / 64k / 88.2k / 96k / 176.4k / 192kHz
Serial μP Interface		4-wire	4-wire/I <sup>2</sup> C (max.400kHz)
Error Handling Pins		AUTO, ERF, FS96	INT0, INT1
Master Clock Output Frequency		128fs/256fs/512fs	64fs/128fs/256fs/512fs
Channel Status Bit		32bit	40bit
MCKO2 Clock Source in serial control mode		Depend on CM1-0 bits	Depend on CM1-0, XMCK and BCU bits
Audio I/F at Reset in serial control mode		Master Mode	Slave Mode
Package		28pin VSOP	30pin VSOP

**2. Pin Layout**

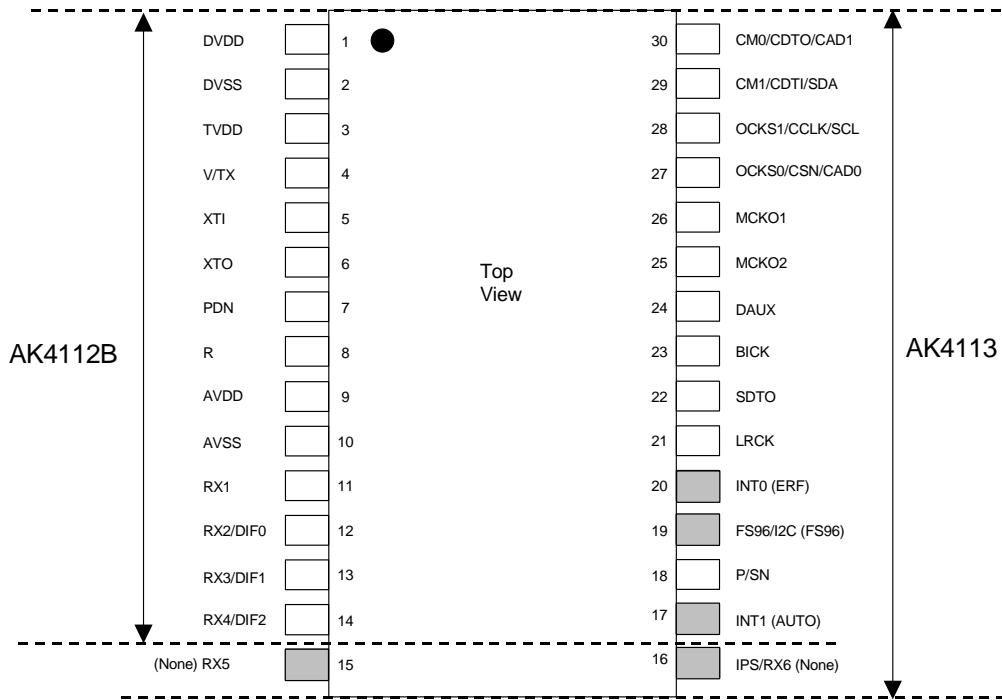

Note:

- 1) Light gray highlights indicate the difference between AK4112B and AK4113.
- 2) The inside of “( )” indicates the pin name of AK4112B.

**3. Control register**

Control registers of between AK4112B and AK4113 are not compatible.

**ABSOLUTE MAXIMUM RATING**

(AVSS, DVSS=0V; Note 2)

Parameter		Symbol	min	max	Units
Power Supplies:	Analog	AVDD	-0.3	4.6	V
	Digital	DVDD	-0.3	4.6	V
	Input Buffer	TVDD	-0.3	6.0	V
	AVSS-DVSS  (Note 3)	$\Delta$ GND		0.3	V
Input Current (Any pins except supplies)		IIN	-	$\pm$ 10	mA
Input Voltage		VIN	-0.3	TVDD+0.3	V
Ambient Temperature (Power applied)		Ta	-40	85	°C
Storage Temperature		Tstg	-65	150	°C

Note 2. All voltage with respect to ground.

Note 3. AVSS and DVSS must be connected to the same ground.

WARNING: Operation at or beyond these limits may result in permanent damage to the device

Normal operation is not guaranteed at these extremes.

**RECOMMEND OPERATING CONDITIONS**

(AVSS, DVSS=0V; Note 2)

Parameter		Symbol	min	typ	max	Units
Power Supplies:	Analog	AVDD	2.7	3.3	3.6	V
	Digital	DVDD	2.7	3.3	3.6	V
	Input Buffer	TVDD	DVDD	3.3	5.5	V
	Difference	AVDD - DVDD	-0.3	0	0.3	V

Note 2. All voltage with respect to ground

**S/PDIF RECEIVER CHARACTERISTICS**

(Ta=25°C; AVDD, DVDD=2.7~3.6V;TVDD=2.7~5.5V)

Parameter	Symbol	min	typ	max	Units
Input Resistance	Zin		10		k $\Omega$
Input Voltage	VTH	350			mVpp
Input Hysteresis	VHY	-	185		mV
Input Sample Frequency	fs	8	-	216	kHz



**DC CHARACTERISTICS**

(Ta=25°C; AVDD, DVDD=2.7~3.6V;TVDD=2.7~5.5V; unless otherwise specified)

Parameter	Symbol	min	typ	max	Units
Power Supply Current					
Normal operation: PDN pin = "H" (Note 4)			26	42	mA
Power down: PDN pin = "L" (Note 5)			10	100	μA
High-Level Input Voltage	VIH	70% DVDD	-	TVDD	V
Low-Level Input Voltage	VIL	DVSS - 0.3	-	30% DVDD	V
High-Level Output Voltage (Except TX pin: Iout=-400μA)	VOH	DVDD-0.4	-	-	V
Low-Level Output Voltage (Except TX and SDA pins: Iout=400μA)	VOL	-	-	0.4	V
( SDA pin: Iout= 3mA)	VOL	-	-	0.4	V
TX Output Level (Note 6)	VTXO	0.4	0.5	0.6	V
Input Leakage Current (Except RX1-6, XTI pins)	Iin	-	-	± 10	μA

Note 4. AVDD, DVDD=3.3V, TVDD=5.0V, CL=20pF, fs=216kHz, X'tal=24.576MHz, Clock Operation Mode 2, OCKS1 bit = "1", OCKS0 bit = "1". TX circuit = Figure 19, Master Mode; AVDD=5mA (typ), DVDD=21mA (typ), TVDD=0.1μA (typ).

Note 5. RX inputs are open and all digital input pins are held DVDD or DVSS.

Note 6. By using Figure 19

**SWITCHING CHARACTERISTICS**

(Ta=25°C; AVDD, DVDD=2.7~3.6V, TVDD=2.7~5.5V; CL=20pF)

Parameter	Symbol	min	typ	max	Units
<b>Master Clock Timing</b>					
Crystal Resonator	Frequency	fXTAL	11.2896	24.576	MHz
External Clock	Frequency	fECLK	11.2896	24.576	MHz
	Duty	dECLK	40	50	%
MCKO1 Output	Frequency	fMCK1	1.024	27.648	MHz
	Duty	dMCK1	40	50	%
MCKO2 Output	Frequency	fMCK2	0.512	27.648	MHz
	Duty	dMCK2	40	50	%
PLL Clock Recover Frequency (RX1-6)	fpll	8	-	216	kHz
LRCK Frequency	fs	8		216	kHz
Duty Cycle	dLCK	45		55	%
<b>Audio Interface Timing</b>					
<b>Slave Mode</b>					
BICK Period	tBCK	72			ns
BICK Pulse Width Low	tBCKL	27			ns
Pulse Width High	tBCKH	27			ns
LRCK Edge to BICK "↑" (Note 7)	tLRB	15			ns
BICK "↑" to LRCK Edge (Note 7)	tBLR	15			ns
LRCK to SDTO (MSB)	tLRM			20	ns
BICK "↓" to SDTO	tBSD			20	ns
DAUX Hold Time	tDXH	15			ns
DAUX Setup Time	tDXS	15			ns
<b>Master Mode</b>					
BICK Frequency	fBCK		64fs		Hz
BICK Duty	dBCK		50		%
BICK "↓" to LRCK	tMBLR	-15		15	ns
BICK "↓" to SDTO	tBSD			15	ns
DAUX Hold Time	tDXH	15			ns
DAUX Setup Time	tDXS	15			ns

Note 7. BICK rising edge must not occur at the same time as LRCK edge.

<b>SWITCHING CHARACTERISTICS (Continued)</b>					
(Ta=25°C; AVDD, DVDD=2.7~3.6V, TVDD=2.7~5.5V; CL=20pF)					
<b>Parameter</b>	<b>Symbol</b>	<b>min</b>	<b>typ</b>	<b>max</b>	<b>Units</b>
<b>Control Interface Timing (4-wire serial mode)</b>					
CCLK Period	tCCK	200			ns
CCLK Pulse Width Low	tCCKL	80			ns
Pulse Width High	tCCKH	80			ns
CDTI Setup Time	tCDS	50			ns
CDTI Hold Time	tCDH	50			ns
CSN "H" Time	tCSW	150			ns
CSN "↓" to CCLK "↑"	tCSS	50			ns
CCLK "↑" to CSN "↑"	tCSH	50			ns
CDTO Delay	tDCD			45	ns
CSN "↑" to CDTO Hi-Z	tCCZ			70	ns
<b>Control Interface Timing (I<sup>2</sup>C Bus mode):</b>					
SCL Clock Frequency	fSCL	-		400	kHz
Bus Free Time Between Transmissions	tBUF	1.3		-	μs
Start Condition Hold Time (prior to first clock pulse)	tHD:STA	0.6		-	μs
Clock Low Time	tLOW	1.3		-	μs
Clock High Time	tHIGH	0.6		-	μs
Setup Time for Repeated Start Condition	tSU:STA	0.6		-	μs
SDA Hold Time from SCL Falling (Note 8)	tHD:DAT	0		-	μs
SDA Setup Time from SCL Rising	tSU:DAT	0.1		-	μs
Rise Time of Both SDA and SCL Lines	tR	-		0.3	μs
Fall Time of Both SDA and SCL Lines	tF	-		0.3	μs
Setup Time for Stop Condition	tSU:STO	0.6		-	μs
Capacitive load on bus	Cb	-		400	pF
Pulse Width of Spike Noise Suppressed by Input Filter	tSP	0		50	ns
<b>Reset Timing</b>					
PDN Pulse Width	tPW	150			ns

Note 8. Data must be held for sufficient time to bridge the 300ns transition time of SCL.

Note 9. I<sup>2</sup>C is a registered trademark of Philips Semiconductors.

Purchase of Asahi Kasei Microsystems Co., Ltd I<sup>2</sup>C components conveys a license under the Philips I<sup>2</sup>C patent to use the components in the I<sup>2</sup>C system, provided the system conform to the I<sup>2</sup>C specifications defined by Philips.

■ Timing Diagram

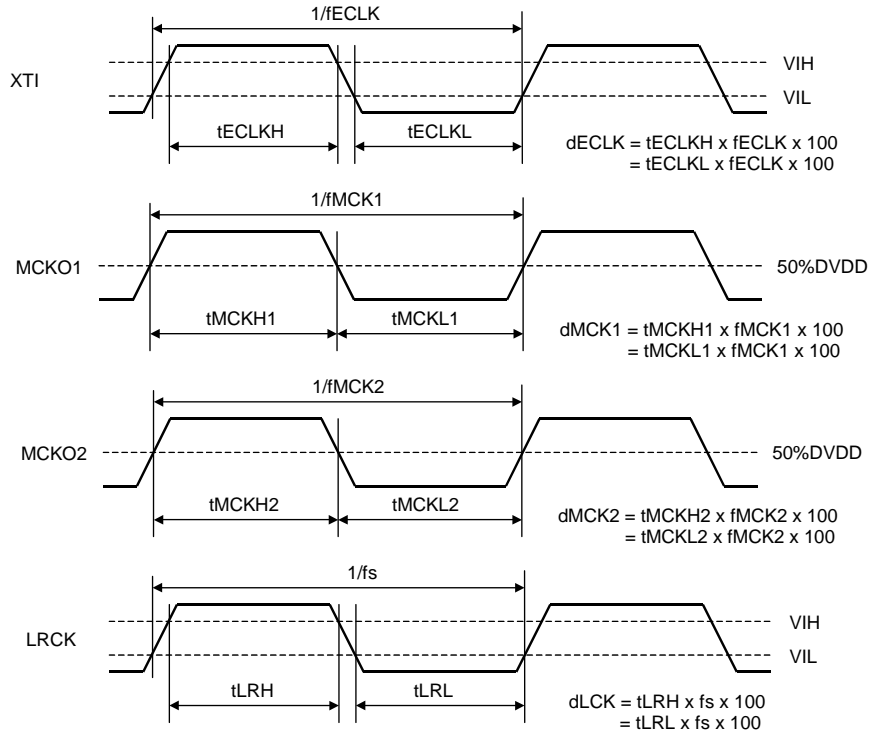

Figure 3. Clock Timing

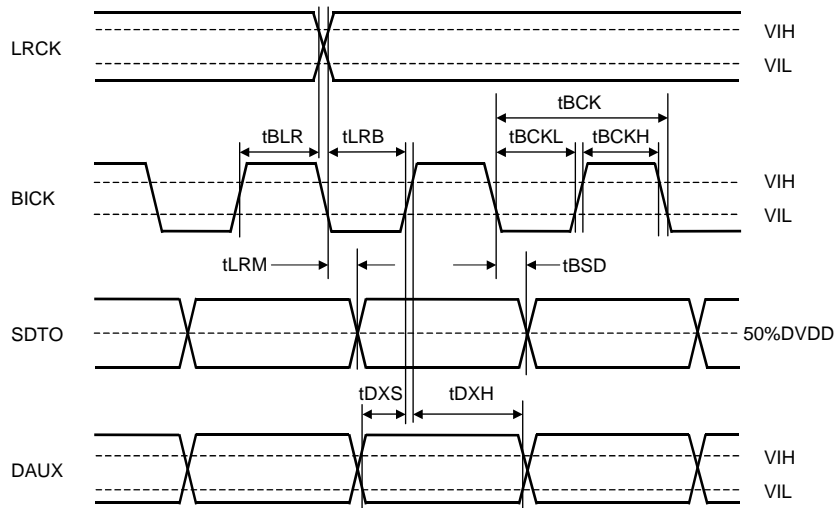

Figure 4. Serial Interface Timing (Slave Mode)

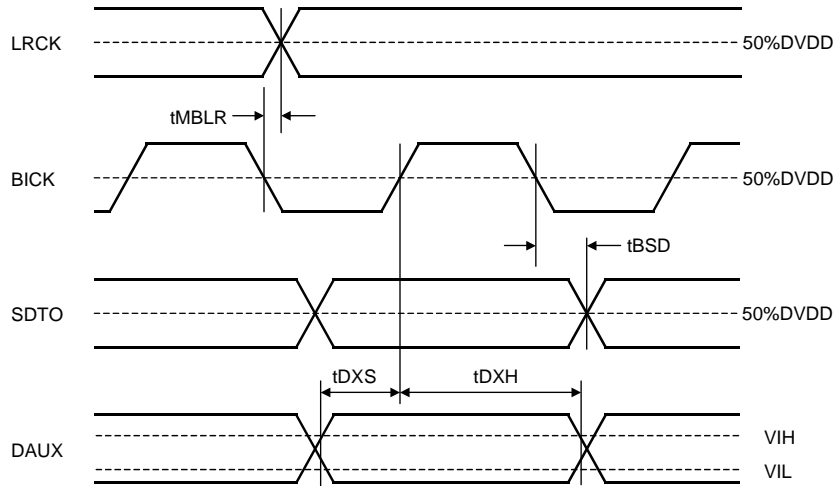

Figure 5. Serial Interface Timing (Master Mode)

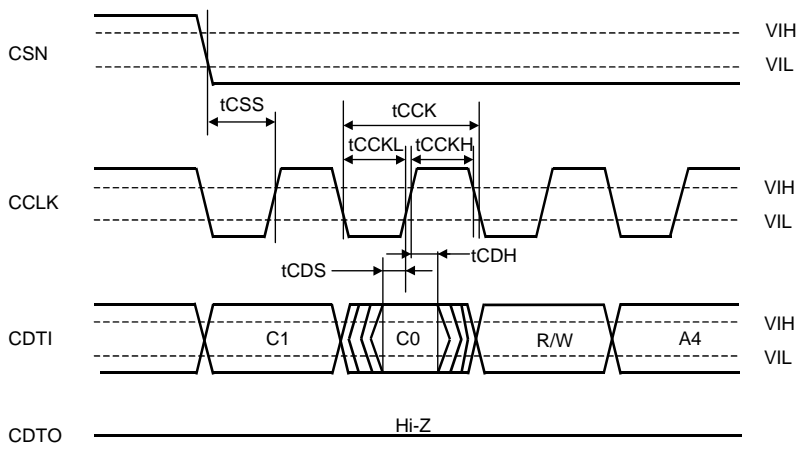

Figure 6. WRITE/READ Command Input Timing (4-wire serial mode)

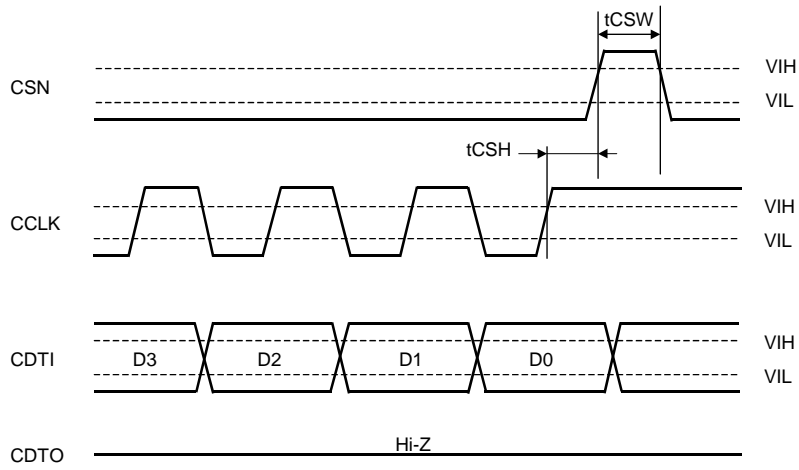

Figure 7. WRITE Data Input Timing (4-wire serial mode)

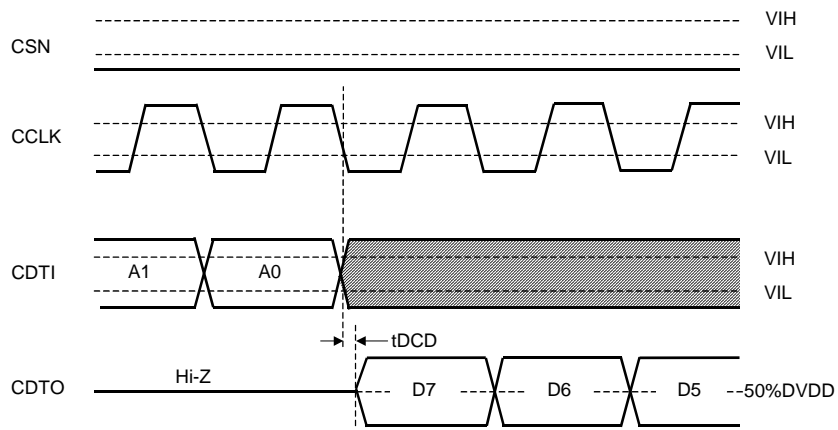

Figure 8. READ Data Output Timing 1 (4-wire serial mode)

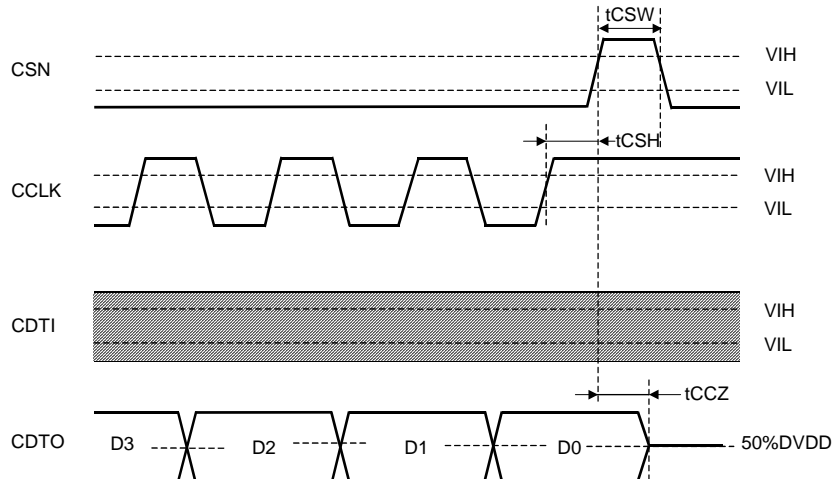

Figure 9. READ Data Output Timing 2 (4-wire serial mode)

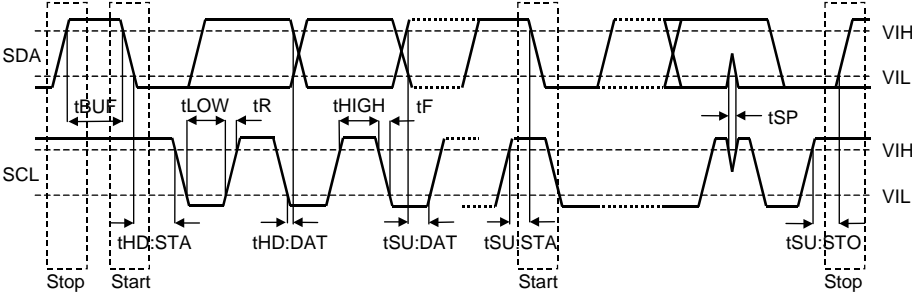

Figure 10. I<sup>2</sup>C Bus Mode Timing

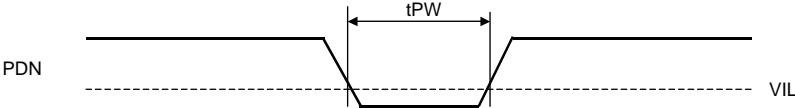

Figure 11. Power-down & Reset Timing

**OPERATION OVERVIEW**

■ **Non-PCM (Dolby Digital, MPEG, etc) and DTS-CD Bitstream Detection**

The AK4113 has a non-PCM bit stream auto-detection function. When the 32bit mode non-PCM preamble based on Dolby “Dolby Digital Data Stream in IEC 60958 Interface” is detected, the NPCM bit sets to “1”. The 96-bit sync code consists of 0x0000, 0x0000, 0x0000, 0x0000, 0xF872 and 0x4E1F. Detection of this pattern will set the NPCM bit to “1”. Once the NPCM bit is set to “1”, it will remain “1” until 4096 frames pass through the chip without an additional sync pattern being detected. When those preambles are detected, the burst preambles Pc (burst information: Table 17) and Pd (length code: Table 18) that follow those sync codes are stored to registers. The AK4113 has also a DTS-CD bitstream auto-detection function. When the AK4113 detects DTS-CD bitstream, the DTSCD bit sets to “1”. If the next sync code does not occur within 4096frames, the DTSCD bit sets to “0” until a non-PCM bitstream is detected again. The ORed value of NPCM and DTSCD bits are output to AUTO bit. The AK4113 detects the 14-bit sync word and the 16-bit sync word of a DTS-CD bitstream, the detection function can be set ON/OFF by DTS14 and DTS16 bits in serial control mode.

In parallel control mode, logical OR value of the AUTO and AUDION bits are outputted to the INTI pin. The DTS-CD detects both the 14-bit sync word and the 16-bit sync word.

■ **216kHz Clock Recovery**

The integrated low jitter PLL has a wide lock range from 8kHz to 216kHz. The lock time depends on sampling frequency (fs) and FAST bit. (See Figure 12) FAST bit is useful at lower sampling frequency and is fixed to “0” in parallel control mode. In serial control mode, the AK4113 has a sampling frequency detection function (8kHz, 11.025kHz, 16kHz, 22.05kHz, 32kHz, 44.1kHz, 48kHz, 64kHz, 88.2kHz, 96kHz, 176.4kHz and 192kHz) that uses either a clock comparison against the X’tal oscillator or the channel status information from the setting of XTL1-0 bits. In parallel control mode, the sampling frequency is detected by using the reference frequency, 24.576MHz. When the sampling frequency is more than 64kHz, FS96 pin goes to “H”. When the sampling frequency is less than 54kHz, FS96 pin goes to “L”. The PLL loses lock when the received sync interval is incorrect.

FAST bit	PLL Lock Time	
0	$\leq (15 \text{ ms} + 384/\text{fs})$	Default
1	$\leq (15 \text{ ms} + 1/\text{fs})$	

Figure 12. PLL Lock Time (fs: Sampling Frequency)

■ Clock Operation Mode

The CM0 and CM1 pins (or bits) select the clock source and the data source of SDTO. In Mode 2, the clock source is switched from PLL to X'tal when PLL goes unlock state. In Mode3, the clock source is fixed to X'tal, but PLL is also operating and the recovered data such as C bits can be monitored. For Mode2 and 3, it is recommended that the frequency of X'tal is different from the recovered frequency from PLL.

Mode	CM1	CM0	UNLOCK	PLL	X'tal	Clock source	SDTO
0	0	0	-	ON	ON (Note)	PLL	RX
1	0	1	-	OFF	ON	X'tal	DAUX
2	1	0	0	ON	ON	PLL	RX
			1	ON	ON	X'tal	DAUX
3	1	1	-	ON	ON	X'tal	DAUX

Default

ON: Oscillation (Power-up), OFF: STOP (Power-Down)

Note: When the X'tal is not used as clock comparison for fs detection (i.e. XTL1-0 bit = "11"), the X'tal is OFF.

Table 1. Clock Operation Mode Select

■ Master Clock

The AK4113 has two clock outputs, MCKO1 and MCKO2. MCKO2 has two modes. These modes can be selected by the XMCK bit.

1) When XMCK bit = "0" and BCU bit = "0"

This mode is compatible AK4112B and AK4114. These clocks are derived from either the recovered clock or the X'tal oscillator. The frequencies of the master clock outputs (MCKO1 and MCKO2) are set by OCKS0 and OCKS1 as shown in Table 2. The 512fs clock will not operate when the sampling frequency is 96kHz or 192kHz. The 256fs clock will not operate when the sampling frequency is 192kHz.

No.	OCKS1	OCKS0	MCKO1 pin	MCKO2 pin	X'tal	fs (max)
0	0	0	256fs	256fs	256fs	108 kHz
1	0	1	256fs	128fs	256fs	108 kHz
2	1	0	512fs	256fs	512fs	54 kHz
3	1	1	128fs	64fs	128fs	216 kHz

Default

Table 2. Master Clock Output Frequency

2) When XMCK bit "1" and BCU bit = "0"

MCKO2 outputs the input clock of the XTI pin when BCU bit = "0" and XMCK bit = "1". The settings of CM1-0 and OCKS1-0 bits are ignored. The output frequency can be set by the DIV bit. MCKO1 outputs a clock that is selected by the CM1-0 bits and OCKS1-0 bits.

XMCK bit	DIV bit	MCKO2 Clock Source	MCKO2 Frequency
1	0	X'tal	x 1
1	1	X'tal	x 1/2

Table 3. Select output frequency of MCKO2



■ Clock Source

The following circuits are available to feed the clock to the XTI pin of the AK4113.

1) X'tal

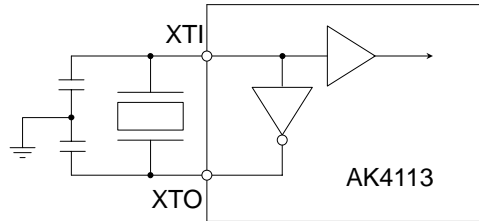

Figure 13. X'tal mode

Note: External capacitance depends upon the crystal oscillator (typ.10-40pF)

2) External clock

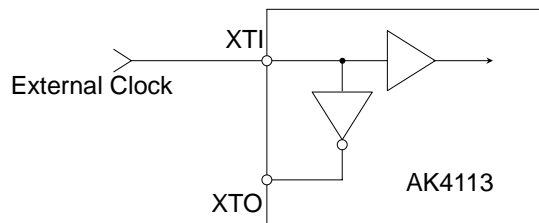

Figure 14. External clock mode

3) Fixed to the Clock Operation Mode 0

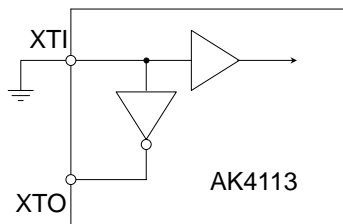

Figure 15. OFF Mode

■ Sampling Frequency and Pre-emphasis Detection

The AK4113 has two methods for detecting the sampling frequency.

1. Clock comparison between the recovered clock and X'tal oscillator
2. Sampling frequency information on channel status

The method is selected by the XTL1-0 bits. The detected frequency is available on the FS3-0 bits.

When XTL1-0 bits = "11", the sampling frequency is detected by the channel status sampling frequency information. The detected frequency is available on the FS3-0 bits. In parallel control mode, XTL1-0 bits are fixed to "10".

XTL1 bit	XTL0 bit	X'tal Frequency
0	0	11.2896MHz
0	1	12.288MHz
1	0	24.576MHz
1	1	(Use channel status)

Default

Table 4. Reference X'tal frequency

Register output				fs	Except XTL1-0 bit = "11"	XTL1-0 bit = "11"		
					Clock comparison (Note 10)	Consumer mode (Note 11)	Professional mode (Note 12)	
FS3	FS2	FS1	FS0			Byte3 Bit3,2,1,0	Byte0 Bit7,6	Byte4 Bit6,5,4,3
0	0	0	0	44.1kHz	44.1kHz ± 3%	0 0 0 0	0 1	0 0 0 0
0	0	0	1	Reserved	-	0 0 0 1	(Others)	
0	0	1	0	48kHz	48kHz ± 3%	0 0 1 0	1 0	0 0 0 0
0	0	1	1	32kHz	32kHz ± 3%	0 0 1 1	1 1	0 0 0 0
0	1	0	0	22.05kHz	22.05kHz ± 3%	0 1 0 0	0 0	1 0 0 1
0	1	0	1	11.025kHz	11.025kHz ± 3%			
0	1	1	0	24kHz	24kHz ± 3%	0 1 1 0	0 0	0 0 0 1
0	1	1	1	16kHz	16kHz ± 3%			
1	0	0	0	88.2kHz	88.2kHz ± 3%	1 0 0 0	0 0	1 0 1 0
1	0	0	1	8kHz	8kHz ± 3%			
1	0	1	0	96kHz	96kHz ± 3%	1 0 1 0	0 0	0 0 1 0
1	0	1	1	64kHz	64kHz ± 3%			
1	1	0	0	176.4kHz	176.4kHz ± 3%	1 1 0 0	0 0	1 0 1 1
1	1	1	0	192kHz	192kHz ± 3%	1 1 1 0	0 0	0 0 1 1

Note 10. At least ±3% range is identified as the value in the. Table 5. In case of intermediate frequency of those two, FS3-0 bits indicate no value. When the frequency is much bigger than 192kHz or much smaller than 8kHz, FS3-0 bits may indicate "0001" or "1101".

Note 11. In consumer mode, Byte3 Bit3-0 are copied to FS3-0 bits.

Note 12. In professional mode, FS3-0 bit indicates "0001" except for frequency shown by Table 5.

Table 5. fs Information

The pre-emphasis information is detected and reported on PEM bit. This information is extracted from channel 1 by default. It can be switched to channel 2 by the CS12 bit in control register.

PEM bit	Pre-emphasis	Byte 0 Bits 3-5
0	OFF	≠ 0X100
1	ON	0X100

Table 6. PEM in Consumer Mode

PEM bit	Pre-emphasis	Byte 0 Bits 2-4
0	OFF	≠ 110
1	ON	110

Table 7. PEM in Consumer Mode

■ De-emphasis Filter Control

The AK4113 includes a digital de-emphasis filter (tc=50/15µs). This is an IIR filter that corresponds to four sampling frequencies (32kHz, 44.1kHz and 48kHz). When DEAU bit="1", the de-emphasis filter is enabled automatically by the sampling frequency and pre-emphasis information in the channel status. The AK4113 is in this mode by default. In parallel control mode, the AK4113 is always placed in this mode and the status bits in channel 1 control the de-emphasis filter. In serial control mode, DEM1-0 bits control the de-emphasis filter when the DEAU is "0". The internal de-emphasis filter is bypassed and the recovered data is available without any change if the de-emphasis mode is OFF. When the PEM bit is "0", the internal de-emphasis filter is always bypassed.

PEM bit	FS3 bit	FS2 bit	FS1 bit	FS0 bit	Mode
1	0	0	0	0	44.1kHz
1	0	0	1	0	48kHz
1	0	0	1	1	32kHz
1	(Others)				OFF
0	x	x	x	x	OFF

Table 8. De-emphasis Auto Control at DEAU bit = "1" (Default)

PEM bit	DEM1 bit	DEM0 bit	Mode
1	0	0	44.1kHz
1	0	1	OFF
1	1	0	48kHz
1	1	1	32kHz
0	x	x	OFF

Default

Table 9. De-emphasis Manual Control at DEAU bit = "0"

## ■ System Reset and Power-Down

The AK4113 has a power-down mode for all circuits using the PDN pin or it can be partially powerd-down with the PWN bit. The RSTN bit initializes the register and resets the internal timing. In parallel control mode, only control by the PDN pin is enabled. The AK4113 should be reset once by bringing PDN pin = "L" upon power-up.

### PDN Pin:

All analog and digital circuits are placed in power-down and reset mode by bringing PDN pin = "L". All the registers are initialized, and clocks are stopped. Reading/Witting to the registers are disabled.

### RSTN Bit (Address 00H; D0):

All the registers except PWN and RSTN bits are initialized by bringing RSTN bit = "0". The internal timings is also initialized. Writing to registers is not available except the PWN and RSTN bits. Reading from the registers is disabled.

### PWN Bit (Address 00H; D1):

The clock recovery is initialized by bringing PWN bit = "0". In this case, the clocks are stopped. The registers are not initialized and the mode settings are maintained. Writing and reading to the registers are enabled.

■ Bi-phase Input

Six receiver inputs (RX1-6) are available in serial control mode. IPS2-0 bits select the receiver channel. In parallel control mode, two receiver inputs (RX1 or RX5) are available. The receiver channel is selected by IPS pin. Each input includes an amplifier for unbalanced mode that can accept a signal of 350mV or more. When BCU and UCE bits are changed, the Block start signal, C bit and U bit can output from each pins. (See Table 12 and Figure 16)

IPS2 bit	IPS1 bit	IPS0 bit	INPUT Data
0	0	0	RX1
0	0	1	RX2
0	1	0	RX3
0	1	1	RX4
1	0	0	RX5
1	0	1	RX6
1	1	0	No use
1	1	1	No use

Default

Table 10. Recovery Data Select at serial control mode

IPS pin	INPUT Data
L	RX1
H	RX5

Table 11. Recovery Data Select at parallel control mode

BCU bit	UCE bit	MCKO2 pin	INT1 pin
0	x (Don't care)	MCKO2 clock output	INT1 output
1	0	Block start signal output	U-bit output
1	1	Block start signal output	C-bit output

Table 12. B, C, U output pins select

(B, C, U, V Output timing at RX mode, Master mode)

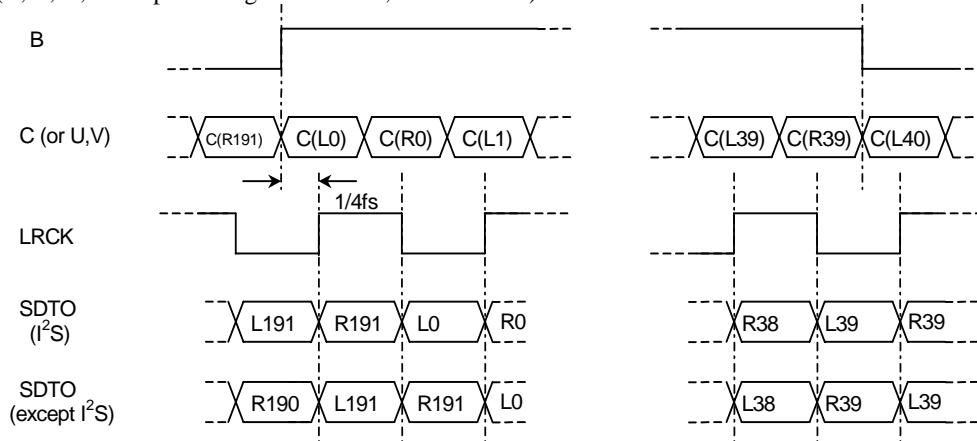

\* The block signal goes high at the start of frame 0 and remains high until the end of frame 39.

Figure 16. B, C, U, V Output Timing

### ■ Bi-phase Output

In serial control mode, the source of the loop-through output from TX is selected from RX1-6. The bi-phase loop-through output is selected by OPS2-0 bits. The bi-phase loop-through output from TX can be stopped by XTE bit. In parallel control mode, the bi-phase loop-through output can not be outputted.

OPS2 bit	OPS1 bit	OPS0 bit	INPUT Data
0	0	0	RX1
0	0	1	RX2
0	1	0	RX3
0	1	1	RX4
1	0	0	RX5
1	0	1	RX6
1	1	0	No use
1	1	1	No use

Default

Table 13. Output Data Select

■ Bi-phase signal input/output circuit

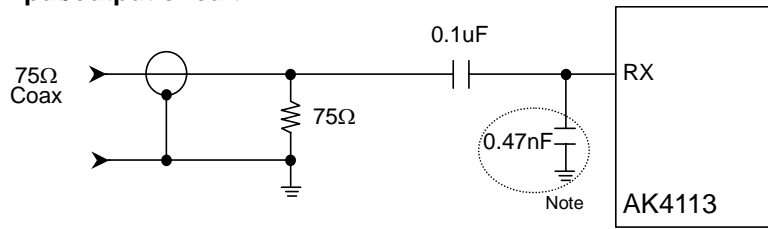

Figure 17. Consumer Input Circuit (Coaxial Input)

Note: For coaxial input, if a coupling level to this input from the next RX input line pattern exceeds 50mV, there may be an incorrect operation. In this case, it is possible to lower the coupling level by adding this decoupling capacitor.

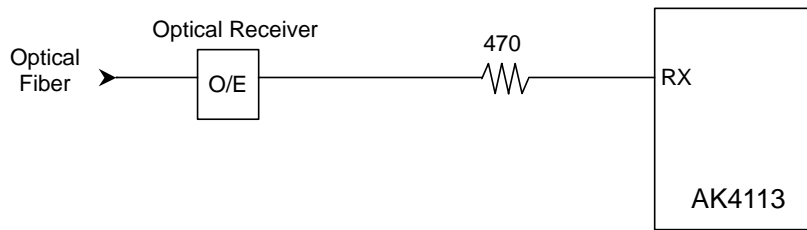

Figure 18. Consumer Input Circuit (Optical Input)

For coaxial input in serial mode, the input level of RX line is small, so care must be taken to avoid crosstalk among the RX input lines. In this case, a shield is recommended between the input lines. In parallel control mode, two channel inputs (RX1 and RX5) are available, RX2, RX3, RX4 and RX6 change to other pins for mode settings. Those pins must be fixed to “H” or “L” because they are not normal logic input.

The AK4113 includes the TX output buffer. The output level meets combination  $0.5V \pm 20\%$  using the external resistor network. The T1 in Figure 19 is a transformer of 1:1.

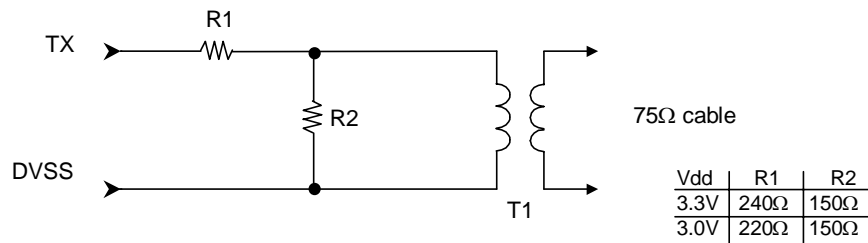

Figure 19. TX External Resistor Network

■ U-bit buffers

The AK4113 has a Q-subcode buffer for CD application. The AK4113 takes the Q-subcode into registers by the following method.

1. The sync word (S0,S1) is constructed of at least 16 "0"s.
2. The start bit is "1".
3. Those 7bits Q-W follows to the start bit.
4. The distance between two start bits are 8-16 bits.

The QINT bit in the control register goes to "1" when the new Q-subcode differs from old one, and goes to "0" when the QINT bit is read.

	1	2	3	4	5	6	7	8	*
S0	0	0	0	0	0	0	0	0	0...
S1	0	0	0	0	0	0	0	0	0...
S2	1	Q2	R2	S2	T2	U2	V2	W2	0...
S3	1	Q3	R3	S3	T3	U3	V3	W3	0...
:	:	:	:	:	:	:	:	:	:
S97	1	Q97	R97	S97	T97	U97	V97	W97	0...
S0	0	0	0	0	0	0	0	0	0...
S1	0	0	0	0	0	0	0	0	0...
S2	1	Q2	R2	S2	T2	U2	V2	W2	0...
S3	1	Q3	R3	S3	T3	U3	V3	W3	0...
:	:	:	:	:	:	:	:	:	:

(\*) number of "0" : min=0; max=8.

Figure 20. Configuration of U-bit (CD)

Q2	Q3	Q4	Q5	Q6	Q7	Q8	Q9	Q10	Q11	Q12	Q13	Q14	Q15	Q16	Q17	Q18	Q19	Q20	Q21	Q22	Q23	Q24	Q25
CTRL				ADRS				TRACK NUMBER								INDEX							
Q26	Q27	Q28	Q29	Q30	Q31	Q32	Q33	Q34	Q35	Q36	Q37	Q38	Q39	Q40	Q41	Q42	Q43	Q44	Q45	Q46	Q47	Q48	Q49
MINUTE						SECOND						FRAME											
Q50	Q51	Q52	Q53	Q54	Q55	Q56	Q57	Q58	Q59	Q60	Q61	Q62	Q63	Q64	Q65	Q66	Q67	Q68	Q69	Q70	Q71	Q72	Q73
ZERO						ABSOLUTE MINUTE						ABSOLUTE SECOND											
Q74	Q75	Q76	Q77	Q78	Q79	Q80	Q81	Q82	Q83	Q84	Q85	Q86	Q87	Q88	Q89	Q90	Q91	Q92	Q93	Q94	Q95	Q96	Q97
ABSOLUTE FRAME								CRC $G(x)=x^{16}+x^{12}+x^5+1$															

Figure 21. Q-subcode

Addr	Register Name	D7	D6	D5	D4	D3	D2	D1	D0
13H	Q-subcode Address / Control	Q9	Q8	...	...	...	...	Q3	Q2
14H	Q-subcode Track	Q17	Q16	...	...	...	...	Q11	Q10
15H	Q-subcode Index	...	...	...	...	...	...	...	...
16H	Q-subcode Minute	...	...	...	...	...	...	...	...
17H	Q-subcode Second	...	...	...	...	...	...	...	...
18H	Q-subcode Frame	...	...	...	...	...	...	...	...
19H	Q-subcode Zero	...	...	...	...	...	...	...	...
1AH	Q-subcode ABS Minute	...	...	...	...	...	...	...	...
1BH	Q-subcode ABS Second	...	...	...	...	...	...	...	...
1CH	Q-subcode ABS Frame	Q81	Q80	...	...	...	...	Q75	Q74

Figure 22. Q-subcode register



## ■ Error Handling

The following nine events cause the INT0 and INT1 pins to show the status of the interrupt condition. When the PLL is OFF (Clock Operation Mode 1), INT0 and INT1 pins go to “L”.

1. UNLCK : PLL unlock state detect  
“1” when the PLL loses lock. The AK4113 loses lock when the distance between two preamble is not correct or when those preambles are not correct.
2. PAR : Parity error or bi-phase coding error detection  
“1” when parity error or bi-phase coding error is detected, updated every sub-frame cycle.
3. AUTO : Non-Linear PCM or DTS-CD Bit Stream detection  
The OR function of NPCM and DTSCD bits is available at the AUTO bit.
4. V : Validity flag detection  
“1” when validity flag is detected. Updated every sub-frame cycle.
5. AUDION : Non-audio detection  
“1” when the “AUDION” bit in recovered channel status indicates “1”. Updated every block cycle.
6. STC : Sampling frequency or pre-emphasis information change detection  
When either FS3-0 bit or PEM bit is changed, it maintains “1” during 1 sub-frame.
7. QINT : U-bit Sync flag  
“1” when the Q-subcode differs from the old one. Updated every sync code cycle for Q-subcode.
8. CINT : Channel status sync flag  
“1” when received C bit differs from the old one. Updated every block cycle.
9. DAT : DAT Start ID detect  
“1” when the category code indicates “DAT” and “DAT Start ID” is detected. When DCNT bit is “1”, it does not indicate “1” even if “DAT Start ID” is detected again within “3841 x LRCK”.  
When “DAT Start ID” is detected again after “3840 x LRCK” passed, it indicates “1”. When DCNT bit is “0”, it indicates “1” every “DAT Start ID” detection.

1. Parallel control mode

In parallel control mode, the INT0 pin outputs the ORed signal between UNLCK and PAR. The INT1 pin outputs the ORed signal between AUTO and AUDION. Once INT0 goes "H", it maintains "H" for 1024/fs cycles after the all error events are removed. Table 14 shows the state of each output pins when the INT0/1 pin is "H".

Event				Pin			
UNLCK	PAR	AUTO	AUDION	INT0	INT1	SDTO	V
1	x	x	x	"H"	Note 13	"L"	"L"
0	1	x	x			Previous Data	Output
0	0	x	x	"L"		Output	Output
x	x	1	x	Note 14	"H"	Note 15	Note 16
x	x	x	1				
x	x	0	0		"L"		

Note 13. INT1 pin outputs "L" or "H" in accordance with the ORed signal between AUTO and AUDION.

Note 14. INT0 pin outputs "L" or "H" in accordance with the ORed signal between UNLCK and PAR.

Note 15. SDTO pin outputs "L", "Previous Data" or "Normal Data" in accordance with the ORed signal between UNLCK and PAR.

Note 16. V pin outputs "L" or "Normal operation" in accordance with the ORed signal between PAR and UNLCK.

Table 14. Error Handling in parallel control mode (x: Don't care)

2. Serial control mode

In serial control mode, the INT1 and INT0 pins output an ORed signal based on the above nine interrupt events. When masked, the interrupt event does not affect the operation of the INT1-0 pins (the masks do not affect the registers in 07H and DAT bit). Once the INT0 pin goes to "H", it remains "H" for 1024/fs (this value can be changed with the EFH1-0 bits) after all events not masked by mask bits are cleared. INT1 pin immediately goes to "L" when those events are cleared.

UNLCK, PAR, AUTO, AUDION and V bits in Address=07H indicate the interrupt status events above in real time. Once QINT, CINT and DAT bits goes to "1", it stays "1" until the register is read.

When the AK4113 loses lock, the channel status bit, user bit, Pc and Pd are initialized. In this initial state, INT0 pin outputs the ORed signal between UNLCK and PAR bits. INT1 pin outputs the ORed signal between AUTO and AUDION bits.

Event			Pin		
UNLCK	PAR	Others	SDTO	V	TX
1	x	x	"L"	"L"	Output
0	1	x	Previous Data	Output	Output
x	x	x	Output	Output	Output

Table 15. Error Handling in serial control mode (x: Don't care)

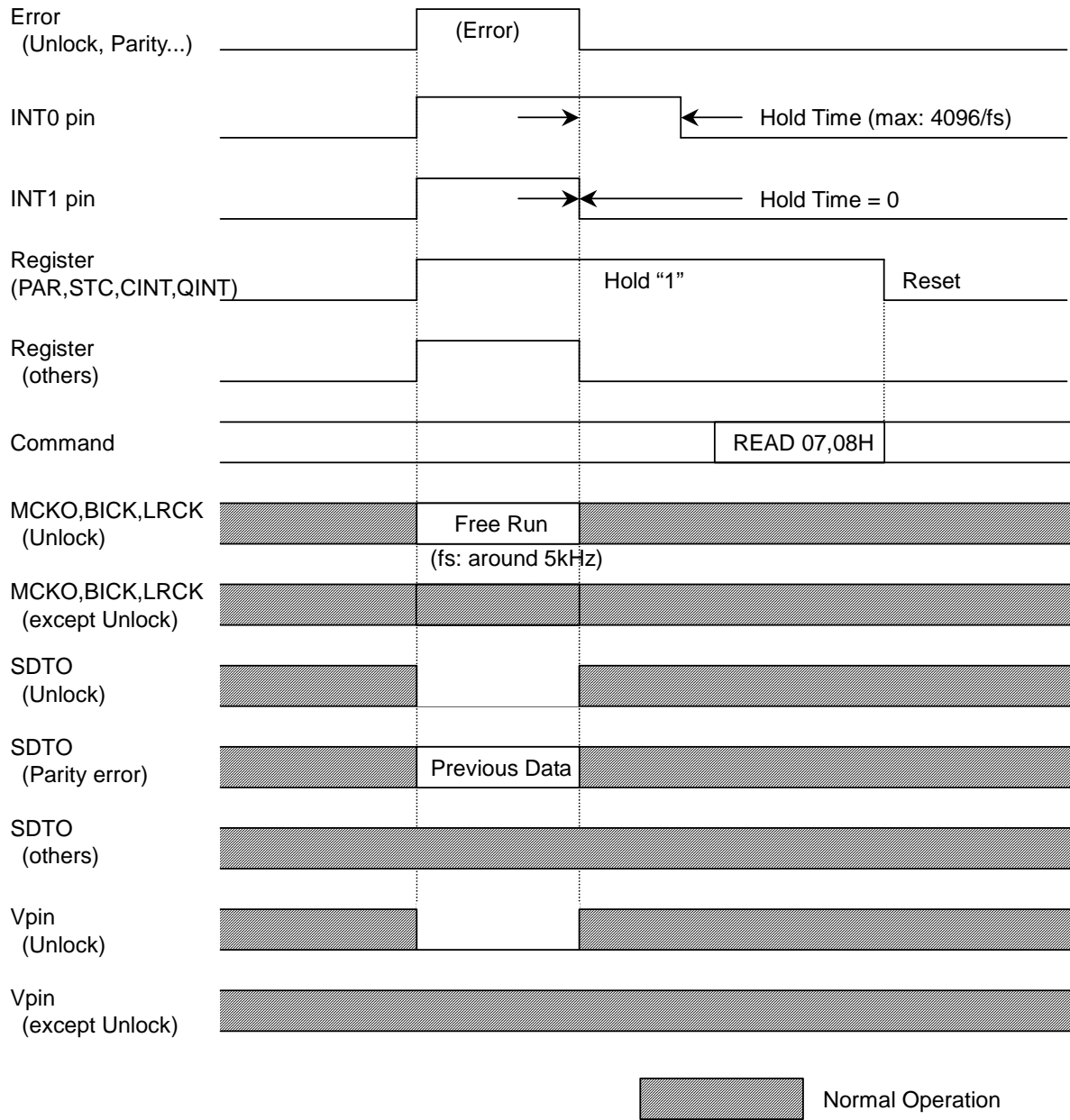

Figure 23. INT0/1 pin Timing

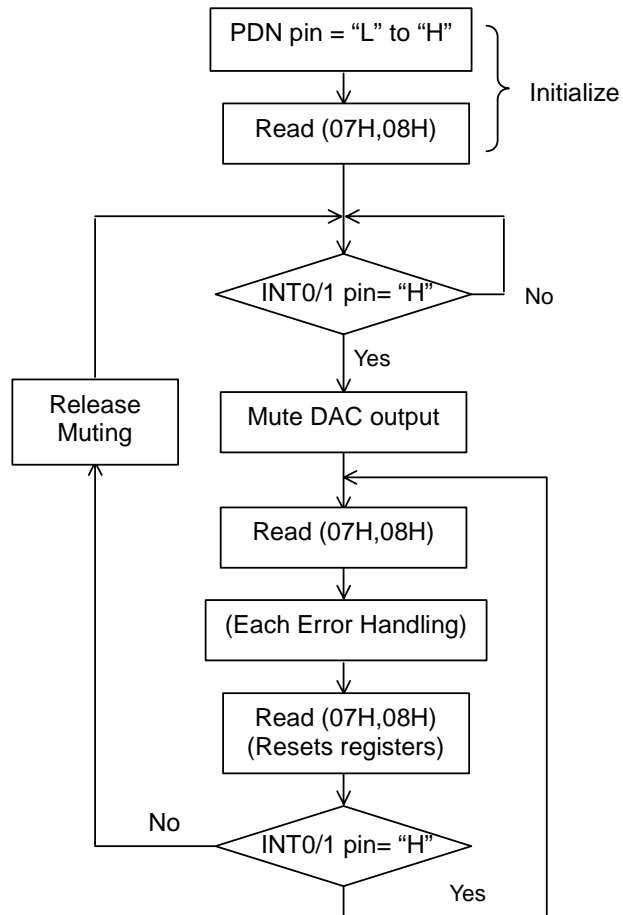

Figure 24. Error Handling Sequence Example 1

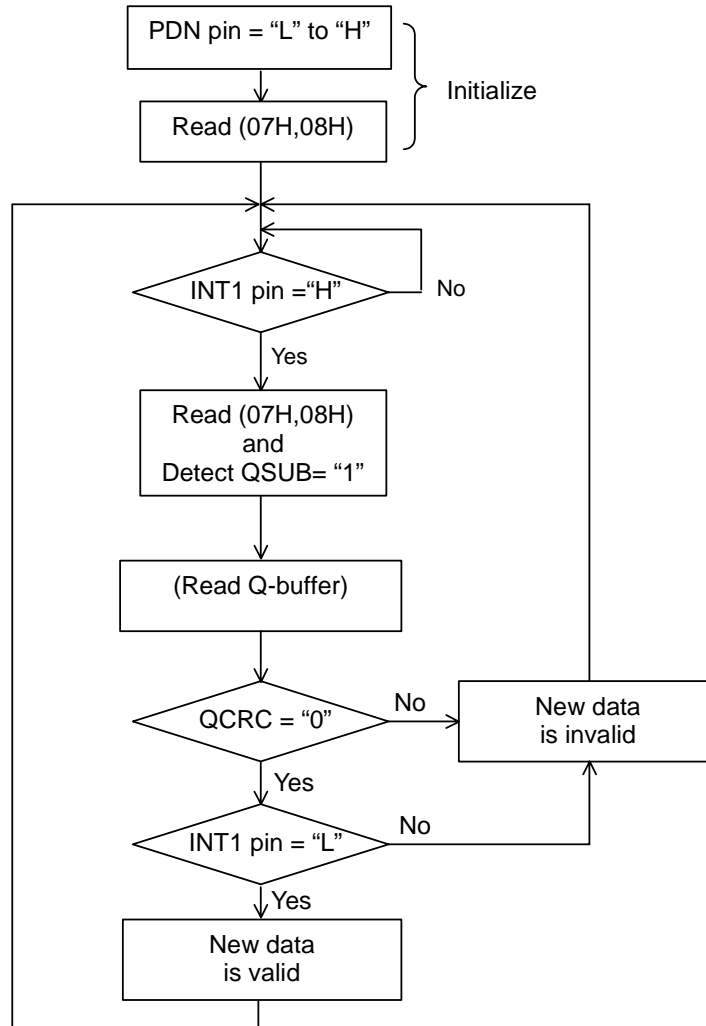

Figure 25. Error Handling Sequence Example (for Q/CINT)

■ Audio Serial Interface Format

The DIF0, DIF1 and DIF2 pins can select eight serial data formats as shown in Table 16. In all formats the serial data is MSB-first, 2's compliment format. The SDTO is clocked out on the falling edge of BICK and DAUX is latched on the rising edge of BICK. BICK outputs 64fs clock in Mode 0-5. Mode 6-7 are Slave Modes, and BICK is available up to 128fs at fs=48kHz. If the data word length is equal or less than 20-bits (Mode0-2), the LSBs in the sub-frame are truncated. In Mode 3-7, the last 4-LSBs are auxiliary data (see Figure 26). When the Parity Error, Bi-phase Error or Frame Length Error occurs in a sub-frame, the AK4113 continues to output the last normal sub-frame data from SDTO repeatedly until the error is removed. When the Unlock Error occurs, AK4113 outputs “0” from SDTO. If DAUX is used, the data is transformed and outputted from SDTO. DAUX is used in Clock Operation Mode 1, 3 and unlock state of Mode 2. The input data format to DAUX should be left justified except in Mode 5 and 7. In Mode 5 or 7, both the input data format of DAUX and output data format of SDTO are I<sup>2</sup>S. Mode 6 and 7 are Slave Modes that corresponds to the Master Mode of Mode 4 and 5. In Slave mode, LRCK and BICK should be synchronized with MCKO1/2.

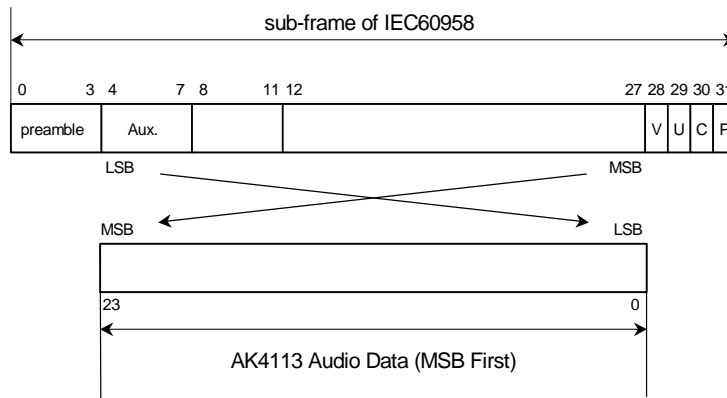

Figure 26. Bit configuration

Mode	DIF2	DIF1	DIF0	DAUX	SDTO	LRCK		BICK	
							I/O		I/O
0	0	0	0	24-bit, Left justified	16-bit, Right justified	H/L	O	64fs	O
1	0	0	1	24-bit, Left justified	18-bit, Right justified	H/L	O	64fs	O
2	0	1	0	24-bit, Left justified	20-bit, Right justified	H/L	O	64fs	O
3	0	1	1	24-bit, Left justified	24-bit, Right justified	H/L	O	64fs	O
4	1	0	0	24-bit, Left justified	24-bit, Left justified	H/L	O	64fs	O
5	1	0	1	24-bit, I <sup>2</sup> S	24-bit, I <sup>2</sup> S	L/H	O	64fs	O
6	1	1	0	24-bit, Left justified	24-bit, Left justified	H/L	I	64-128fs (Note 17)	I
7	1	1	1	24-bit, I <sup>2</sup> S	24-bit, I <sup>2</sup> S	L/H	I	64-128fs (Note 17)	I

Default

Table 16. Audio Data Format

Note 17. This frequency must not exceed a maximum BICK frequency that is defined in “Switching Characteristics”.

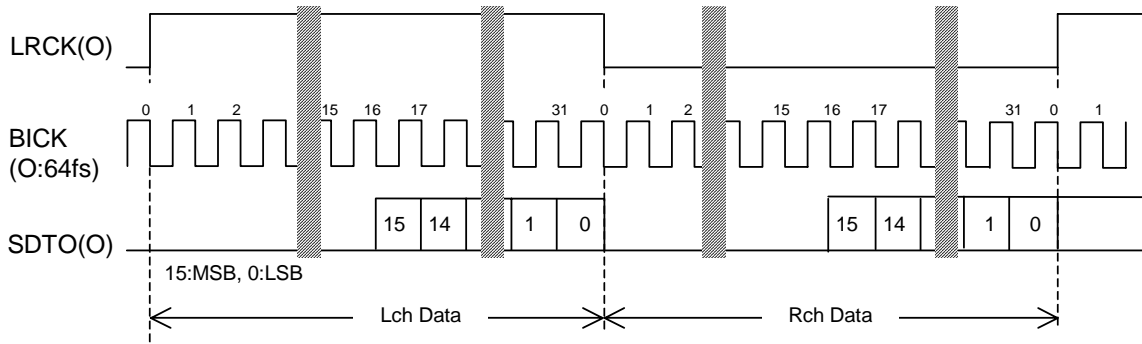

Figure 27. Mode 0 Timing

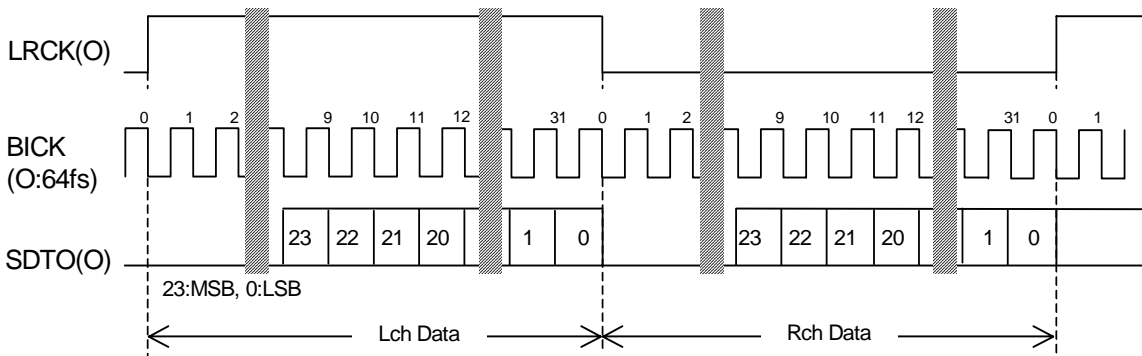

Figure 28. Mode 3 Timing

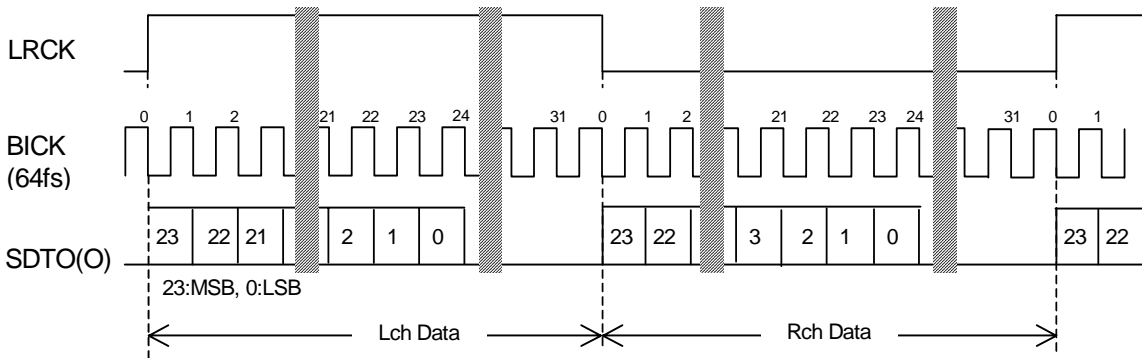

Figure 29. Mode 4, 6 Timing

Mode4 : LRCK, BICK : Output  
 Mode6 : LRCK, BICK : Input

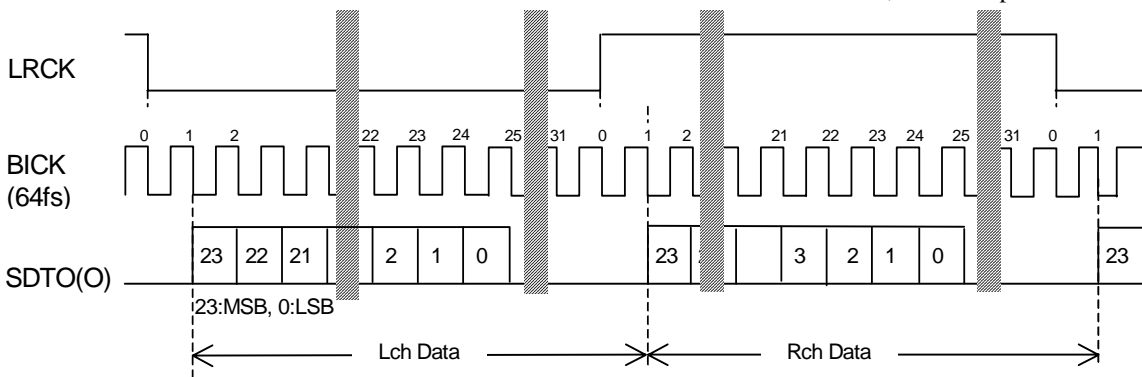

Figure 30. Mode 5, 7 Timing

Mode5 : LRCK, BICK : Output  
 Mode7 : LRCK, BICK : Input

■ Serial Control Interface

1. 4-wire serial control mode (I2C pin = "L")

The internal registers may be either written or read by the 4-wire  $\mu$ P interface pins: CSN, CCLK, CDTI & CDTO. The data on this interface consists of Chip address (2bits, C1-0 are fixed to "00"), Read/Write (1-bit), Register address (MSB first, 5-bits) and Control data (MSB first, 8-bits). Address and data is clocked in on the rising edge of CCLK and data is clocked out on the falling edge. For write operations, data is latched after the 16th rising edge of CCLK, after a high-to-low transition of CSN. For read operations, the CDTO output goes high impedance after a low-to-high transition of CSN. The maximum speed of CCLK is 5MHz. PDN pin = "L" resets the registers to their default values.

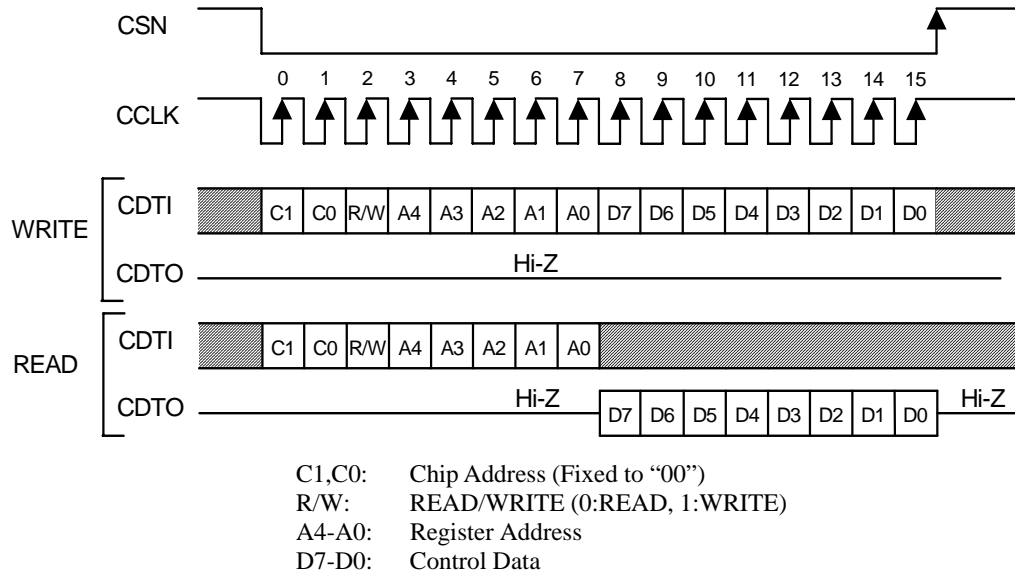

Figure 31. 4-wire Serial Control I/F Timing

\* The control data can not be written when the CCLK rising edge is 15times or less or 17times or more during CSN pin is "L".



**2. I<sup>2</sup>C bus control mode (I2C pin = “H”)**

The AK4113 supports a fast-mode I<sup>2</sup>C-bus system (max : 400kHz).

2-1. Data transfer

All commands are preceded by a START condition. After the START condition, a slave address is sent. After the AK4113 recognizes the START condition, the device interfaced to the bus waits for the slave address to be transmitted over the SDA line. If the transmitted slave address matches an address for one of the devices, the designated slave device pulls the SDA line to LOW (ACKNOWLEDGE). The data transfer is always terminated by a STOP condition generated by the master device.

2-1-1. Data validity

The data on the SDA line must be stable during the HIGH period of the clock. The HIGH or LOW state of the data line can only change when the clock signal on the SCL line is LOW except for the START and the STOP condition.

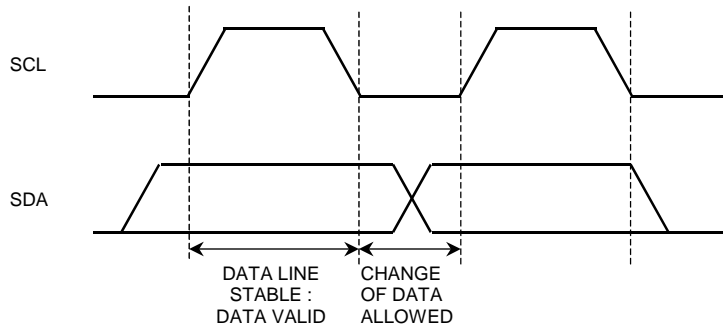

Figure 32. Data transfer

2-1-2. START and STOP condition

A HIGH to LOW transition on the SDA line while SCL is HIGH indicates a START condition. All sequences start from the START condition.

A LOW to HIGH transition on the SDA line while SCL is HIGH defines a STOP condition. All sequences end by the STOP condition.

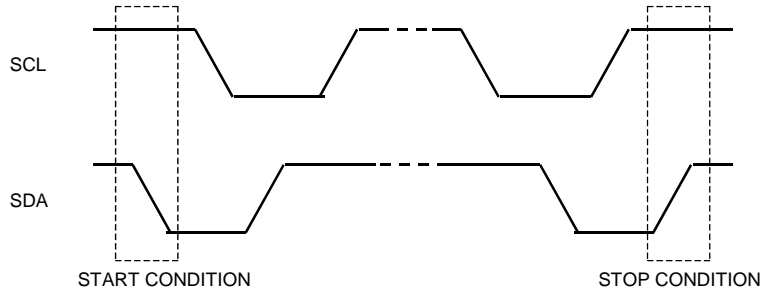

Figure 33. START and STOP conditions

2-1-3. ACKNOWLEDGE

ACKNOWLEDGE is a software convention used to indicate successful data transfers. The transmitting device will release the SDA line (HIGH) after transmitting eight bits. The receiver must pull down the SDA line during the acknowledge clock pulse so that that it remains stable “L” during “H” period of this clock pulse. The AK4113 will generate an acknowledge after each byte has been received.

In the read mode, the slave, the AK4113 will transmit eight bits of data, release the SDA line and monitor the line for an acknowledge. If an acknowledge is detected and no STOP condition is generated by the master, the slave will continue to transmit data. If an acknowledge is not detected, the slave will terminate further data transmissions and await the STOP condition.

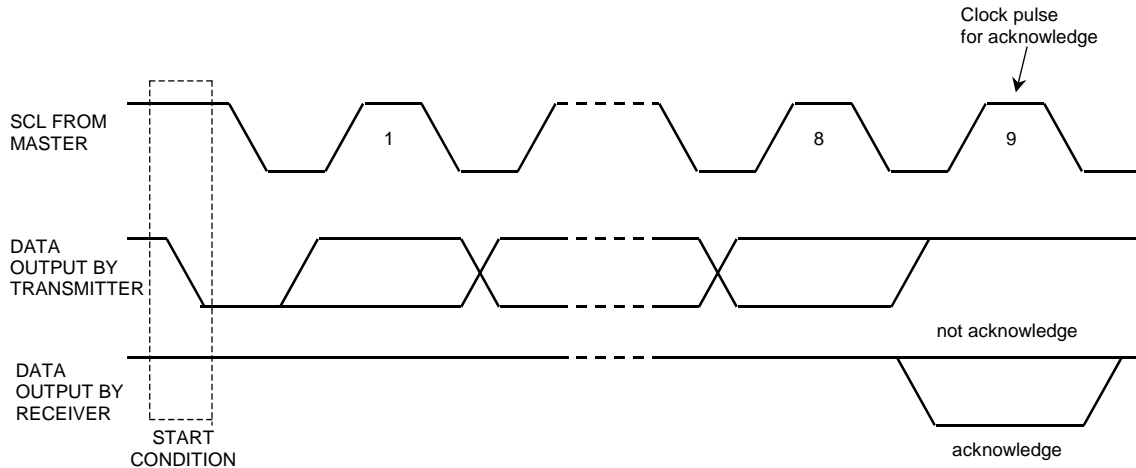
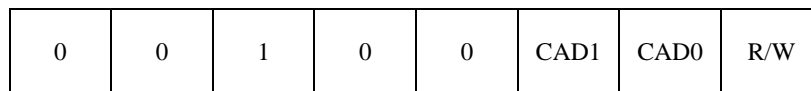

Figure 34. Acknowledge on the I<sup>2</sup>C-bus

2-1-4. FIRST BYTE

The first byte, which includes seven bits of slave address and one bit of R/W bit, is sent after the START condition. If the transmitted slave address matches an address for one of the device, the receiver who has been addressed pulls down the SDA line.

The most significant five bits of the slave address are fixed as “00100”. The next two bits are CAD1 and CAD0 (device address bits). These two bits identify the specific device on the bus. The hard-wired input pins (CAD1 pin and CAD0 pin) set them. The eighth bit (LSB) of the first byte (R/W bit) defines whether a write or read condition is requested by the master. A “1” indicates that the read operation is to be executed. A “0” indicates that the write operation is to be executed.



(Those CAD1/0 should match with CAD1/0 pins.)

Figure 35. The First Byte

2-2. WRITE Operations

Set R/W bit = “0” for the WRITE operation of AK4113.

After receipt the start condition and the first byte, the AK4113 generates an acknowledge, and awaits the second byte (register address). The second byte consists of the address for control registers of AK4113. The format is MSB first, and those most significant 3-bits are “Don’t care”.

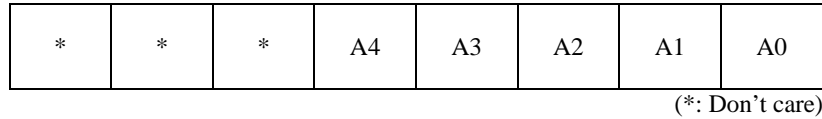

Figure 36. The Second Byte

After receipt the second byte, the AK4113 generates an acknowledge, and awaits the third byte. Those data after the second byte contain control data. The format is MSB first, 8bits.

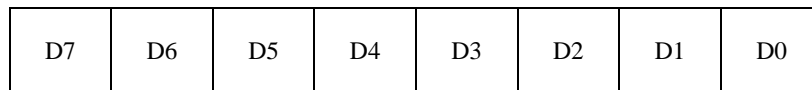

Figure 37. Byte structure after the second byte

The AK4113 is capable of more than one byte write operation by one sequence.

After receipt of the third byte, the AK4113 generates an acknowledge, and awaits the next data again. The master can transmit more than one words instead of terminating the write cycle after the first data word is transferred. After the receipt of each data, the internal 5bits address counter is incremented by one, and the next data is taken into next address automatically. If the address exceed 1CH prior to generating the stop condition, the address counter will “roll over” to 00H and the previous data will be overwritten.

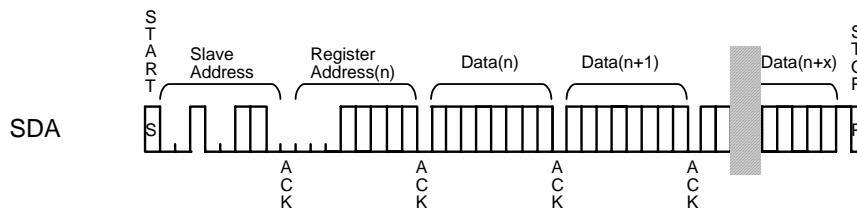

Figure 38. WRITE Operation

2-3. READ Operations

Set R/W bit = “1” for the READ operation of AK4113.

After transmission of a data, the master can read next address’s data by generating the acknowledge instead of terminating the write cycle after the receipt the first data word. After the receipt of each data, the internal 5bits address counter is incremented by one, and the next data is taken into next address automatically. If the address exceed 1CH prior to generating the stop condition, the address counter will “roll over” to 00H and the previous data will be overwritten.

The AK4113 supports two basic read operations: CURRENT ADDRESS READ and RANDOM READ.

2-3-1. CURRENT ADDRESS READ

The AK4113 contains an internal address counter that maintains the address of the last word accessed, incremented by one. Therefore, if the last access (either a read or write) was to address n, the next CURRENT READ operation would access data from the address n+1.

After receipt of the slave address with R/W bit set to “1”, the AK4113 generates an acknowledge, transmits 1byte data which address is set by the internal address counter and increments the internal address counter by 1. If the master does not generate an acknowledge to the data but generate the stop condition, the AK4113 discontinues transmission

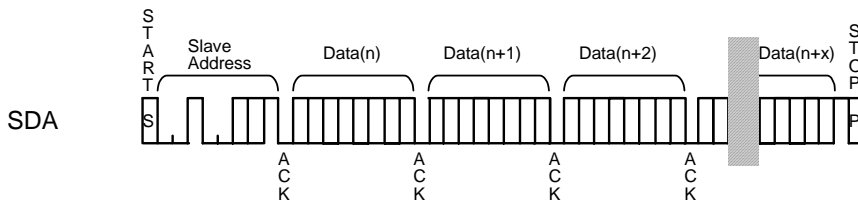

Figure 39. CURRENT ADDRESS READ

2-3-2. RANDOM READ

Random read operation allows the master to access any memory location at random. Prior to issuing the slave address with the R/W bit set to “1”, the master must first perform a “dummy” write operation.

The master issues the start condition, slave address(R/W bit =“0”) and then the register address’s acknowledge, the master immediately reissues the start condition and the slave address with the R/W bit set to “1”. Then the AK4113 generates an acknowledge, 1byte data and increments the internal address counter by 1. If the master does not generate an acknowledge to the data but generate the stop condition, the AK4113 discontinues transmission.

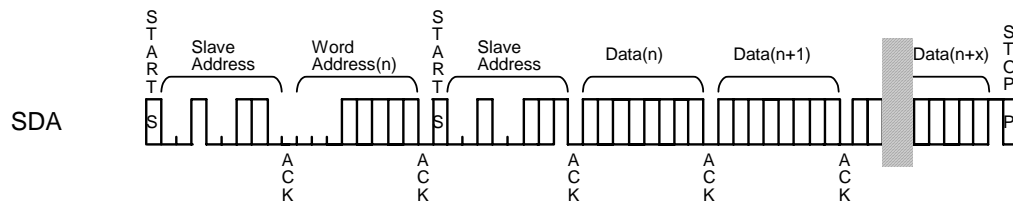

Figure 40. RANDOM READ

## ■ Register Map

Addr	Register Name	D7	D6	D5	D4	D3	D2	D1	D0
00H	CLK & Power Down Control	CS12	BCU	CM1	CM0	OCKS1	OCKS0	PWN	RSTN
01H	Format & De-em Control	V/TX	DIF2	DIF1	DIF0	DEAU	DEM1	DEM0	0
02H	Input/ Output Control 0	0	XTL1	XTL0	UCE	TXE	OPS2	OPS1	OPS0
03H	Input/ Output Control 1	EFH1	EFH0	FAST	XMCK	DIV	IPS2	IPS1	IPS0
04H	INT0 MASK	MQIT0	MAUT0	MCIT0	MULK0	MV0	MSTC0	MAUD0	MPAR0
05H	INT1 MASK	MQIT1	MAUT1	MCIT1	MULK1	MV1	MSTC1	MAUD1	MPAR1
06H	DAT Mask & DTS Detect	0	0	0	DCNT	DTS16	DTS14	MDAT1	MDAT0
07H	Receiver status 0	QINT	AUTO	CINT	UNLCK	V	STC	AUDION	PAR
08H	Receiver status 1	FS3	FS2	FS1	FS0	PEM	DAT	DTSCD	NPCM
09H	Receiver status 2	0	0	0	0	0	0	QCRC	CCRC
0AH	RX Channel Status Byte 0	CR7	CR6	CR5	CR4	CR3	CR2	CR1	CR0
0BH	RX Channel Status Byte 1	CR15	CR14	CR13	CR12	CR11	CR10	CR9	CR8
0CH	RX Channel Status Byte 2	CR23	CR22	CR21	CR20	CR19	CR18	CR17	CR16
0DH	RX Channel Status Byte 3	CR31	CR30	CR29	CR28	CR27	CR26	CR25	CR24
0EH	RX Channel Status Byte 4	CR39	CR38	CR37	CR36	CR35	CR34	CR33	CR32
0FH	Burst Preamble Pc Byte 0	PC7	PC6	PC5	PC4	PC3	PC2	PC1	PC0
10H	Burst Preamble Pc Byte 1	PC15	PC14	PC13	PC12	PC11	PC10	PC9	PC8
11H	Burst Preamble Pd Byte 0	PD7	PD6	PD5	PD4	PD3	PD2	PD1	PD0
12H	Burst Preamble Pd Byte 1	PD15	PD14	PD13	PD12	PD11	PD10	PD9	PD8
13H	Q-subcode Address/Control	Q9	Q8	Q7	Q6	Q5	Q4	Q3	Q2
14H	Q-subcode Track	Q17	Q16	Q15	Q14	Q13	Q12	Q11	Q10
15H	Q-subcode Index	Q25	Q24	Q23	Q22	Q21	Q20	Q19	Q18
16H	Q-subcode Minute	Q33	Q32	Q31	Q30	Q29	Q28	Q27	Q26
17H	Q-subcode Second	Q41	Q40	Q39	Q38	Q37	Q36	Q35	Q34
18H	Q-subcode Frame	Q49	Q48	Q47	Q46	Q45	Q44	Q43	Q42
19H	Q-subcode Zero	Q57	Q56	Q55	Q54	Q53	Q52	Q51	Q50
1AH	Q-subcode ABS Minute	Q65	Q64	Q63	Q62	Q61	Q60	Q59	Q58
1BH	Q-subcode ABS Second	Q73	Q72	Q71	Q70	Q69	Q68	Q67	Q66
1CH	Q-subcode ABS Frame	Q81	Q80	Q79	Q78	Q77	Q76	Q75	Q74

Note: When PDN pin goes “L”, the registers are initialized to their default values.

When RSTN bit goes “0”, the internal timing is reset and the registers are initialized to their default values.

All data can be written to the register even if PWN bit is “0”.

For addresses from 1DH to 1FH, data must not write.

■ Register Definitions

Reset & Initialize

Addr	Register Name	D7	D6	D5	D4	D3	D2	D1	D0
00H	CLK & Power Down Control	CS12	BCU	CM1	CM0	OCKS1	OCKS0	PWN	RSTN
	R/W	R/W	R/W	R/W	R/W	R/W	R/W	R/W	R/W
	Default	0	0	0	0	0	0	1	1

RSTN: Timing Reset & Register Initialize

- 0: Reset & Initialize
- 1: Normal Operation (Default)

PWN: Power Down

- 0: Power Down
- 1: Normal Operation (Default)

OCKS1-0: Master Clock Frequency Select (See Table 2)

CM1-0: Master Clock Operation Mode Select (See Table 1)

BCU: Block start (B) , C, U Output Mode (See Table 12)

- 0: Disable (Default)
- 1: Enable

CS12: Channel Status Select

- 0: Channel 1 (Default)
- 1: Channel 2

Select which channel status is used to derive C-bit buffer, AUDION, PEM, FS3-0, Pc and Pd. The de-emphasis filter is controlled by channel 1 in the parallel control mode.

Format & De-emphasis Control

Addr	Register Name	D7	D6	D5	D4	D3	D2	D1	D0
01H	Format & De-em Control	V/TX	DIF2	DIF1	DIF0	DEAU	DEM1	DEM0	0
	R/W	R/W	R/W	R/W	R/W	R/W	R/W	R/W	RD
	Default	0	1	1	0	1	0	1	0

DEM1-0: 32, 44.1, 48kHz De-emphasis Control (See Table 9)

DEAU: De-emphasis Auto Detect Enable

- 0: Disable
- 1: Enable (Default)

DIF2-0: Audio Data Format Control (See Table 16; Default: “110”)

V/TX: V/TX Output Select

- 0: Validity Flag Output. (Default)  
This output is updated every fs cycle.
- 1: TX

**Input/Output Control**

Addr	Register Name	D7	D6	D5	D4	D3	D2	D1	D0
02H	Input/ Output Control 0	0	XTL1	XTL0	UCE	TXE	OPS2	OPS1	OPS0
	R/W	RD	R/W	R/W	R/W	R/W	R/W	R/W	R/W
	Default	0	0	0	0	1	0	0	0

OPS2-0: Output Through Data Select for TX pin (See Table 13; Default: “000”)  
 TXE: TX pin Output Enable  
     0: Disable. TX pin outputs “L”.  
     1: Enable (Default)  
 UCE: C-bit, U-bit output setting (See Table 12, Default: “0”)  
 XTL1-0: Reference X’tal frequency Select (See Table 4, Default: 00)

Addr	Register Name	D7	D6	D5	D4	D3	D2	D1	D0
03H	Input/ Output Control 1	EFH1	EFH0	FAST	XMCK	DIV	IPS2	IPS1	IPS0
	R/W	R/W	R/W	R/W	R/W	R/W	R/W	R/W	R/W
	Default	0	1	0	0	0	0	0	0

IPS2-0: Input Recovery Data Select (See Table 10; Default: “000”)  
 DIV: MCKO2 Output Frequency Select at X’tal Mode (See Table 3)  
     0: x 1 (Default)  
     1: x 1/2  
 XMCK: MCKO2 pit output select (See Table 3)  
     0: Depends on CM1-0 bits and OCKS1-0 bits (Default)  
     1: Fixed to X’tal Mode  
 FAST: PLL Lock Time Select  
     0:  $\leq (15\text{ms} + 384/\text{fs})$  (Default)  
     1:  $\leq (15\text{ms} + 1/\text{fs})$   
 EFH1-0: INT0 pin Hold Time Select  
     00: 512/fs  
     01: 1024/fs (Default)  
     10: 2048/fs  
     11: 4096/fs

**Mask Control for INT0**

Addr	Register Name	D7	D6	D5	D4	D3	D2	D1	D0
04H	INT0 MASK	MQIT0	MAUTO	MCIT0	MULK0	MV0	MSTC0	MAUD0	MPAR0
	R/W	R/W	R/W	R/W	R/W	R/W	R/W	R/W	R/W
	Default	1	1	1	0	1	1	1	0

- MPAR0: Mask enable for PAR bit  
 0: Mask disable (Default)  
 1: Mask enable
- MAUD0: Mask enable for AUDION bit  
 0: Mask disable  
 1: Mask enable (Default)
- MSTC0: Mask enable for STC bit  
 0: Mask disable  
 1: Mask enable (Default)
- MV0: Mask enable for V bit  
 0: Mask disable  
 1: Mask enable (Default)
- MULK0: Mask enable for UNLCK bit  
 0: Mask disable (Default)  
 1: Mask enable
- MCIT0: Mask enable for CINT bit  
 0: Mask disable  
 1: Mask enable (Default)
- MAUTO: Mask enable for AUTO bit  
 0: Mask disable  
 1: Mask enable (Default)
- MQIT0: Mask enable for QINT bit  
 0: Mask disable  
 1: Mask enable (Default)

When mask is set to “1”, corresponding event does not affect INT0 pin operation.



**Mask Control for INT1**

Addr	Register Name	D7	D6	D5	D4	D3	D2	D1	D0
05H	INT1 MASK	MQIT1	MAUT1	MCIT1	MULK1	MV1	MSTC1	MAUD	MPAR1
	R/W	R/W	R/W	R/W	R/W	R/W	R/W	R/W	R/W
	Default	1	0	1	1	1	1	0	1

- MPAR1: Mask enable for PAR bit  
0: Mask disable  
1: Mask enable (Default)
- MAUD1: Mask enable for AUDION bit  
0: Mask disable (Default)  
1: Mask enable
- MSTC1: Mask enable for STC bit  
0: Mask disable  
1: Mask enable (Default)
- MV1: Mask enable for V bit  
0: Mask disable  
1: Mask enable (Default)
- MULK1: Mask enable for UNLCK bit  
0: Mask disable  
1: Mask enable (Default)
- MCIT1: Mask enable for CINT bit  
0: Mask disable  
1: Mask enable (Default)
- MAUT1: Mask enable for AUTO bit  
0: Mask disable (Default)  
1: Mask enable
- MQIT1: Mask enable for QINT bit  
0: Mask disable  
1: Mask enable (Default)

When mask is set to “1”, corresponding event does not affect INT1 pin operation.

**DAT Mask & DTS Detect**

Addr	Register Name	D7	D6	D5	D4	D3	D2	D1	D0
06H	DAT Mask & DTS Detect	0	0	0	DCNT	DTS16	DTS14	MDAT1	MDAT0
	R/W	RD	RD	RD	R/W	R/W	R/W	R/W	R/W
	Default	0	0	0	1	1	1	1	1

- MDAT0: Mask enable for DAT bit  
0: Mask disable  
1: Mask enable (Default)  
When mask is set to “1”, DAT event does not affect INT0 pin operation.
- MDAT1: Mask enable for DAT bit  
0: Mask disable  
1: Mask enable (Default)  
When mask is set to “1”, DAT event does not affect INT1 pin operation.
- DTS14: DTS-CD 14bit Sync Word Detect  
0: Disable  
1: Enable (Default)
- DTS16: DTS-CD 16bit Sync Word Detect  
0: Disable  
1: Enable (Default)
- DCNT: DAT Start ID Counter  
0: Disable  
1: Enable (Default)

**Receiver Status 0**

Addr	Register Name	D7	D6	D5	D4	D3	D2	D1	D0
07H	Receiver status 0	QINT	AUTO	CINT	UNLCK	V	STC	AUDION	PAR
	R/W	RD	RD	RD	RD	RD	RD	RD	RD
	Default	0	0	0	0	0	0	0	0

PAR: Parity Error or Bi-phase Error Status

0: No Error

1: Error

This bit goes to “1”, if a Parity Error or Biphase Error is detected in the sub-frame.

AUDION: Audio Bit Output

0: Audio

1: Non Audio

This bit is made by encoding channel status bits.

STC: Sampling Frequency or Pre-emphasis Information Change Detection

0: No detect

1: Detect

This bit goes to “1” when either the FS3-0 or PEM bit changes.

V: Validity of channel status

0: Valid

1: Invalid

UNLCK: PLL Lock Status

0: Lock

1: Unlock

CINT: Channel Status Buffer Interrupt

0: No change

1: Changed

This bit goes to “1” when C-bit stored in register addresses 0AH to 0EH changes.

AUTO: Non-PCM Auto Detect

0: No detect

1: Detect

QINT: Q-subcode Buffer Interrupt

0: No change

1: Changed

This bit goes to “1” when Q-subcode stored in register addresses 13H to 1CH changes.

STC, QINT, CINT and PAR bits are initialized when 07H is read.

**Receiver Status 1**

Addr	Register Name	D7	D6	D5	D4	D3	D2	D1	D0
08H	Receiver status 1	FS3	FS2	FS1	FS0	PEM	DAT	DTSCD	NPCM
	R/W	RD	RD	RD	RD	RD	RD	RD	RD
	Default	0	0	0	1	0	0	0	0

NPCM: Non-PCM Bit Stream Auto Detection

0: No detect

1: Detect

DTSCD: DTS-CD Bit Stream Auto Detection

0: No detect

1: Detect

DAT: DAT Start ID Detect

0: No detect

1: Detect

DAT bit is initialized when 08H is read.

PEM: Pre-emphasis Detect

0: OFF

1: ON

This bit is made by encoding channel status bits.

FS3-0: Sampling Frequency detection (See Table 5)

**Receiver Status 1**

Addr	Register Name	D7	D6	D5	D4	D3	D2	D1	D0
09H	Receiver status 1	0	0	0	0	0	0	QCRC	CCRC
	R/W	RD	RD	RD	RD	RD	RD	RD	RD
	Default	0	0	0	0	0	0	0	0

CCRC: Cyclic Redundancy Check for Channel Status

0: No error

1: Error

This bit is enabled only in professional mode and only for the channel selected by the CS12 bit.

QCRC: Cyclic Redundancy Check for Q-subcode

0: No error

1: Error

**Receiver Channel Status**

Addr	Register Name	D7	D6	D5	D4	D3	D2	D1	D0
0AH	RX Channel Status Byte 0	CR7	CR6	CR5	CR4	CR3	CR2	CR1	CR0
0BH	RX Channel Status Byte 1	CR15	CR14	CR13	CR12	CR11	CR10	CR9	CR8
0CH	RX Channel Status Byte 2	CR23	CR22	CR21	CR20	CR19	CR18	CR17	CR16
0DH	RX Channel Status Byte 3	CR31	CR30	CR29	CR28	CR27	CR26	CR25	CR24
0EH	RX Channel Status Byte 4	CR39	CR38	CR37	CR36	CR35	CR34	CR33	CR32
R/W		RD							
Default		Not initialized							

CR39-0: Receiver Channel Status Byte 4-0  
 All 40 bits are updated at the same time every bock (192 frames) cycle.

**Burst Preamble Pc/Pd in non-PCM encoded Audio Bitstreams**

Addr	Register Name	D7	D6	D5	D4	D3	D2	D1	D0
0FH	Burst Preamble Pc Byte 0	PC7	PC6	PC5	PC4	PC3	PC2	PC1	PC0
10H	Burst Preamble Pc Byte 1	PC15	PC14	PC13	PC12	PC11	PC10	PC9	PC8
11H	Burst Preamble Pd Byte 0	PD7	PD6	PD5	PD4	PD3	PD2	PD1	PD0
12H	Burst Preamble Pd Byte 1	PD15	PD14	PD13	PD12	PD11	PD10	PD9	PD8
R/W		RD							
Default		Not initialized							

PC15-0: Burst Preamble Pc Byte 0 and 1  
 PD15-0: Burst Preamble Pd Byte 0 and 1

**Q-subcode Buffer**

Addr	Register Name	D7	D6	D5	D4	D3	D2	D1	D0
13H	Q-subcode Address / Control	Q9	Q8	Q7	Q6	Q5	Q4	Q3	Q2
14H	Q-subcode Track	Q17	Q16	Q15	Q14	Q13	Q12	Q11	Q10
15H	Q-subcode Index	Q25	Q24	Q23	Q22	Q21	Q20	Q19	Q18
16H	Q-subcode Minute	Q33	Q32	Q31	Q30	Q29	Q28	Q27	Q26
17H	Q-subcode Second	Q41	Q40	Q39	Q38	Q37	Q36	Q35	Q34
18H	Q-subcode Frame	Q49	Q48	Q47	Q46	Q45	Q44	Q43	Q42
19H	Q-subcode Zero	Q57	Q56	Q55	Q54	Q53	Q52	Q51	Q50
1AH	Q-subcode ABS Minute	Q65	Q64	Q63	Q62	Q61	Q60	Q59	Q58
1BH	Q-subcode ABS Second	Q73	Q72	Q71	Q70	Q69	Q68	Q67	Q66
1CH	Q-subcode ABS Frame	Q81	Q80	Q79	Q78	Q77	Q76	Q75	Q74
R/W		RD							
Default		Not initialized							

Q2-81: Q-subcode (Figure 20 and Figure 21 )  
 All 80 bits are updated at the same time every sync code cycle for Q-subcode.

■ Burst Preambles in non-PCM Bitstreams

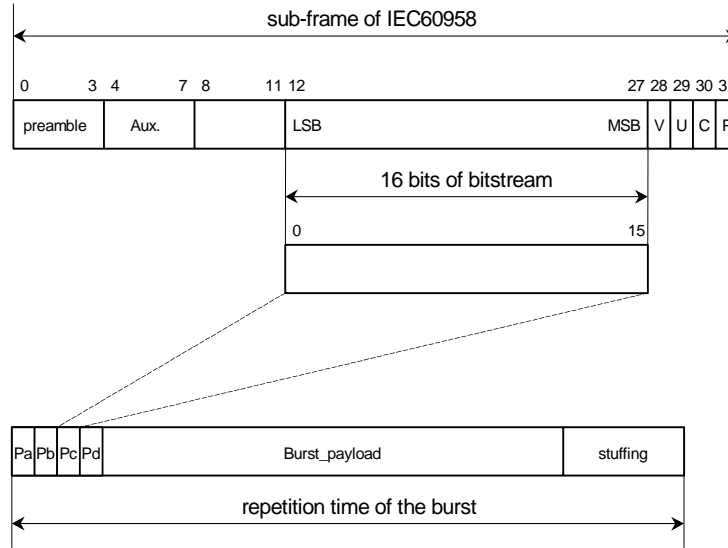

Figure 41. Data structure in IEC60958

Preamble word	Length of field	Contents	Value
Pa	16 bits	sync word 1	0xF872
Pb	16 bits	sync word 2	0x4E1F
Pc	16 bits	Burst info	see Table 18
Pd	16 bits	Length code	numbers of bits

Table 17. Burst preamble words

Bits of Pc	Value	Contents	Repetition time of burst in IEC60958 frames
0-4	0	data type NULL data	≤4096
	1	Dolby AC-3 data	1536
	2	reserved	
	3	PAUSE	
	4	MPEG-1 Layer1 data	384
	5	MPEG-1 Layer2 or 3 data or MPEG-2 without extension	1152
	6	MPEG-2 data with extension	1152
	7	MPEG-2 AAC ADTS	1024
	8	MPEG-2, Layer1 Low sample rate	384
	9	MPEG-2, Layer2 or 3 Low sample rate	1152
	10	reserved	
	11	DTS type I	512
	12	DTS type II	1024
	13	DTS type III	2048
	14	ATRAC	512
	15	ATRAC2/3	1024
16-31	reserved		
5, 6	0	reserved, shall be set to "0"	
7	0	error-flag indicating a valid burst_payload	
	1	error-flag indicating that the burst_payload may contain errors	
8-12		data type dependent info	
13-15	0	bit stream number, shall be set to "0"	

Table 18. Fields of burst info Pc

■ Non-PCM Bitstream timing

1) When Non-PCM preamble is not coming within 4096 frames.

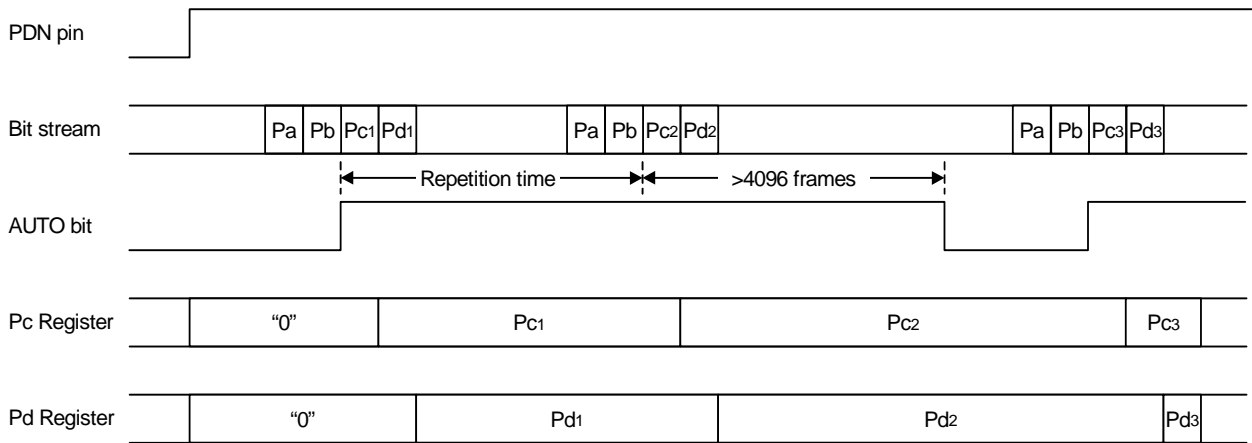

Figure 42. Timing Example 1

2) When Non-PCM bitstream stops (When MULK0 bit = "0")

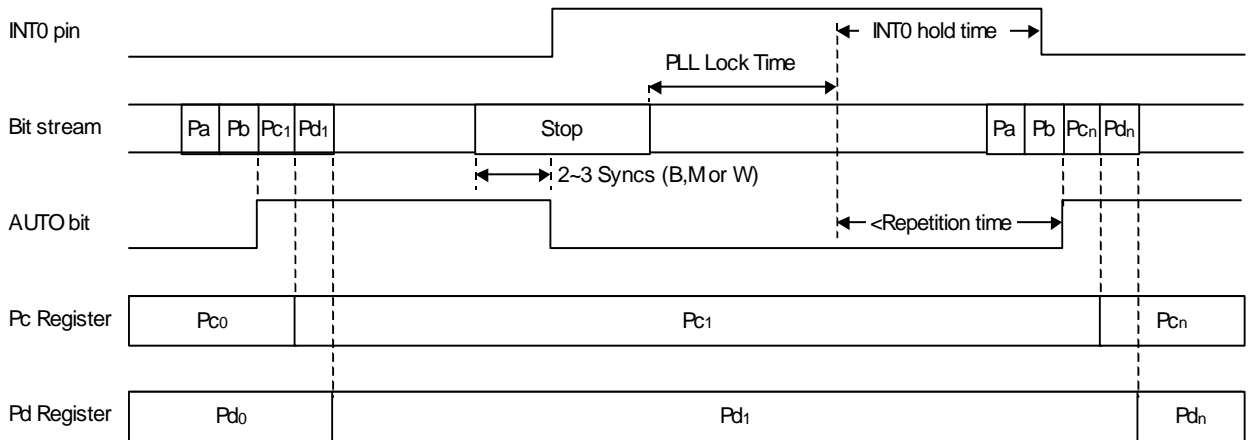

Figure 43. Timing Example 2

**SYSTEM DESIGN**

Figure 44 shows the example of system connection diagram for serial control mode.

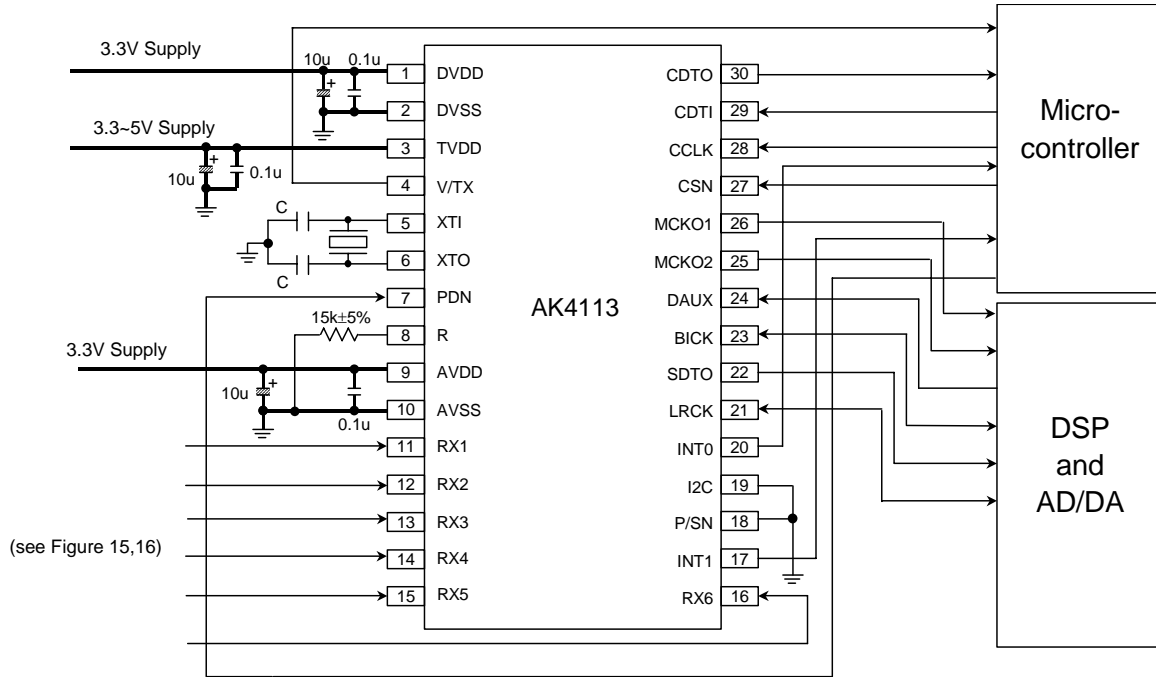

Figure 44. Typical Connection Diagram (4-wire serial control mode)

Notes:

- For setting of XTL1-0 bits, refer to Table 4.
- “C” depends on the crystal oscillator
- AVSS and DVSS must be connected the same ground plane.
- Digital signals, especially clocks, should be kept away from the R pin in order to avoid an effect to the clock jitter performance.

**PACKAGE**

**30pin VSOP (Unit: mm)**

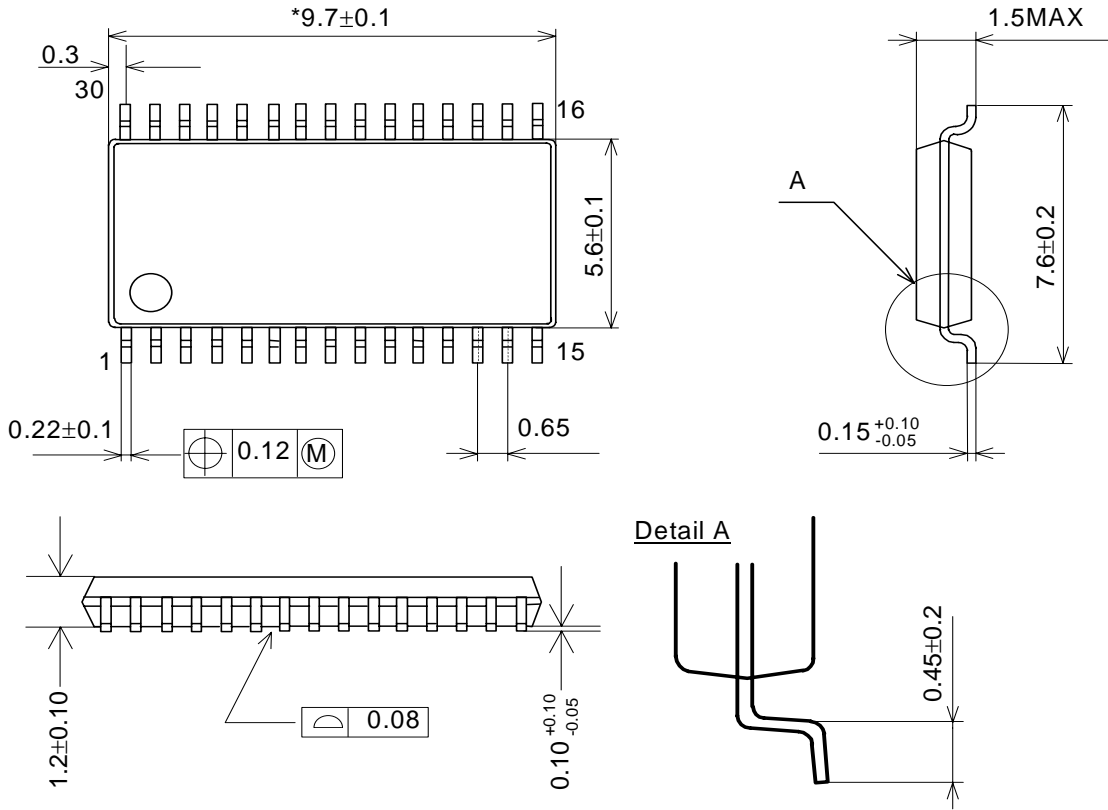

NOTE: Dimension "\*" does not include mold flash.

**Material & Lead finish**

- Package molding compound: Epoxy
- Lead frame material: Cu
- Lead frame surface treatment: Solder plate (Pb Free)



**MARKING**

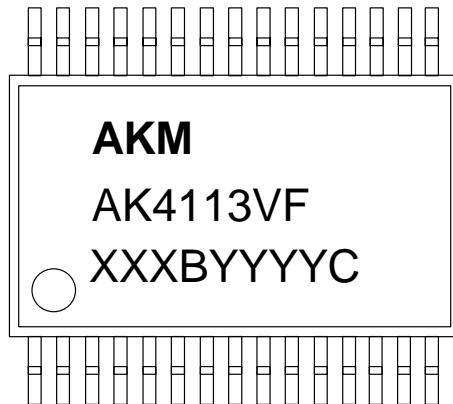

XXXXBYYYYC: Date code identifier

XXXXB: Lot number (X : Digit number, B : Alpha character )

YYYYC: Assembly date (Y : Digit number C : Alpha character)

**Revision History**

Date (YY/MM/DD)	Revision	Reason	Page	Contents
04/10/20	00	First Edition		
05/03/08	01	Error Correct	3, 5, 7	Pin Name: #14; RX4/IPS2 → RX4/DIF2

IMPORTANT NOTICE

- These products and their specifications are subject to change without notice. Before considering any use or application, consult the Asahi Kasei Microsystems Co., Ltd. (AKM) sales office or authorized distributor concerning their current status.
- AKM assumes no liability for infringement of any patent, intellectual property, or other right in the application or use of any information contained herein.
- Any export of these products, or devices or systems containing them, may require an export license or other official approval under the law and regulations of the country of export pertaining to customs and tariffs, currency exchange, or strategic materials.
- AKM products are neither intended nor authorized for use as critical components in any safety, life support, or other hazard related device or system, and AKM assumes no responsibility relating to any such use, except with the express written consent of the Representative Director of AKM. As used here:
  - (a) A hazard related device or system is one designed or intended for life support or maintenance of safety or for applications in medicine, aerospace, nuclear energy, or other fields, in which its failure to function or perform may reasonably be expected to result in loss of life or in significant injury or damage to person or property.
  - (b) A critical component is one whose failure to function or perform may reasonably be expected to result, whether directly or indirectly, in the loss of the safety or effectiveness of the device or system containing it, and which must therefore meet very high standards of performance and reliability.
- It is the responsibility of the buyer or distributor of an AKM product who distributes, disposes of, or otherwise places the product with a third party to notify that party in advance of the above content and conditions, and the buyer or distributor agrees to assume any and all responsibility and liability for and hold AKM harmless from any and all claims arising from the use of said product in the absence of such notification.