

## 50mA ADJUSTABLE CMOS LDO WITH SHUTDOWN

### FEATURES

- Zero Ground Current for Longer Battery Life!
- Adjustable Output Voltage
- Very Low Dropout Voltage
- Guaranteed 50mA Output
- Power-Saving Shutdown Mode
- Over-Current and Over-Temperature Protection
- Space-Saving SOT-23A-5 Package
- Pin Compatible with LP2980 and MIC5205 Regulators

### APPLICATIONS

- Battery Operated Systems
- Portable Computers
- Medical Instruments
- Instrumentation
- Cellular / GSM / PHS Phones
- Linear Post-Regulator for SMPS
- Pagers

### GENERAL DESCRIPTION

The TC1070 is an adjustable LDO designed to supercede a variety of older (bipolar) voltage regulators. Designed specifically for battery-operated systems, the TC1070's CMOS construction eliminates wasted ground current, significantly extending battery life. Total supply current is typically 50µA at full load (*20 to 60 times lower than in bipolar regulators!*).

TC1070 key features include ultra low noise operation very low dropout voltage (typically 100mV at full load) and internal feed-forward compensation for fast response to step changes in load. Supply current is reduced to less than 1µA when the shutdown input is low. The TC1070 incorporates both over-temperature and over-current protection. Output voltage is programmed with a simple resistor divider from V<sub>OUT</sub> to ADJ.

The TC1070 is stable with an output capacitor of only 1µF and has a maximum output current of 50mA. For higher output versions, please see the TC1107, TC1108 (I<sub>OUT</sub> = 300mA) data sheets.

### ORDERING INFORMATION

Part No.	Output Voltage <sup>**</sup> (V)	Package	Junction Temp. Range
TC1070VCT	Adjustable	SOT-23A-5*	-40°C to +125°C

NOTE: \*SOT-23A-5 is equivalent to the EIAJ (SC-74A)

\*\* Other output voltages available. Please contact TelCom Semiconductor for details

### TYPICAL APPLICATION

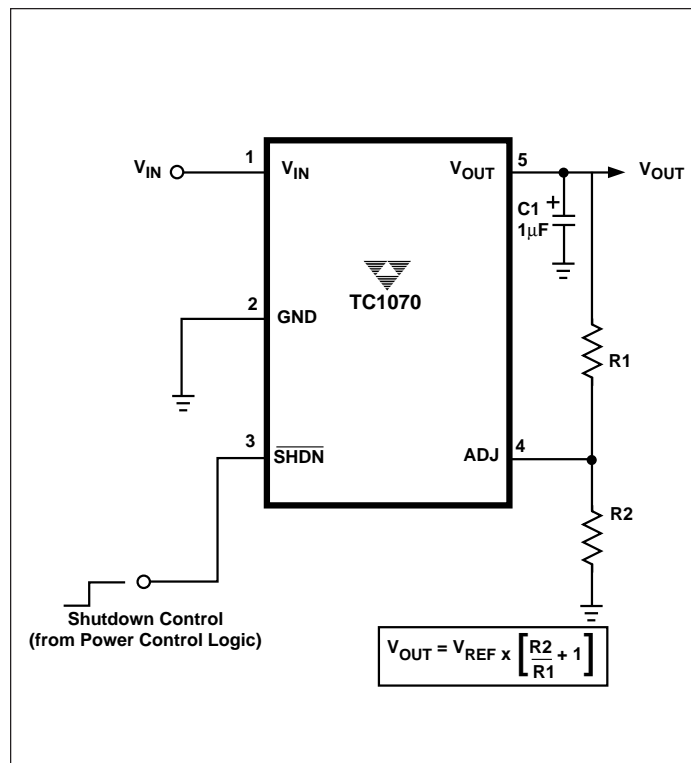

### PIN CONFIGURATION

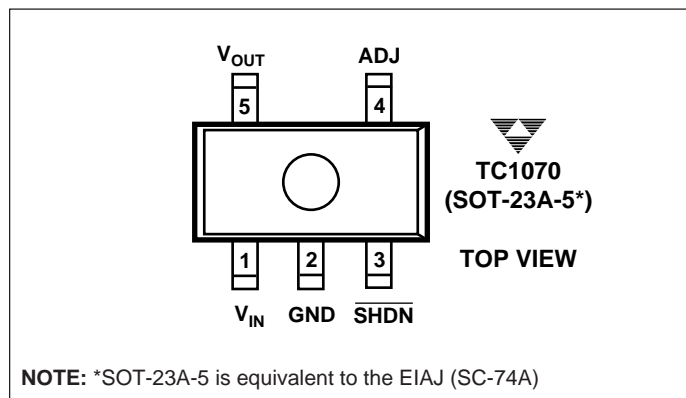

NOTE: \*SOT-23A-5 is equivalent to the EIAJ (SC-74A)

## TC1070

## ABSOLUTE MAXIMUM RATINGS\*

Input Voltage .....	7V
Output Voltage .....	(- 0.3) to (V <sub>IN</sub> + 0.3)
Power Dissipation .....	Internally Limited (Note 7)
Operating Temperature .....	- 40°C < T <sub>J</sub> < 125°C
Storage Temperature .....	- 65°C to +150°C
Maximum Voltage on Any Pin .....	V <sub>IN</sub> + 0.3V to - 0.3V
Lead Temperature (Soldering, 10 Sec.) .....	+260°C

\*Stresses beyond those listed under "Absolute Maximum Ratings" may cause permanent damage to the device. These are stress ratings only, and functional operation of the device at these or any other conditions beyond those indicated in the operational sections of the specifications is not implied. Exposure to absolute maximum rating conditions for extended periods may affect device reliability.

**ELECTRICAL CHARACTERISTICS:** V<sub>IN</sub> = V<sub>OUT</sub> + 1V, I<sub>L</sub> = 0.1mA, C<sub>L</sub> = 3.3μF,  $\overline{\text{SHDN}} > V_{IH}$ , T<sub>A</sub> = 25°C, unless otherwise specified. **BOLDFACE** type specifications apply for junction temperatures of - 40°C to +125°C.

Symbol	Parameter	Test Conditions	Min	Typ	Max	Units
V <sub>IN</sub>	Input Operating Voltage		—	—	<b>6.5</b>	V
I <sub>OUTMAX</sub>	Maximum Output Current		<b>50</b>	—	—	mA
V <sub>OUT</sub>	Output Voltage	V <sub>REF</sub> ≤ V <sub>OUT</sub> ≤ (V <sub>IN</sub> - 0.05) I <sub>L</sub> = 0 (Note 1)	<b>V<sub>R</sub> - 2.5%</b>	V <sub>R</sub> ± 0.5%	<b>V<sub>R</sub> + 2.5%</b>	V
V <sub>REF</sub>	Reference Voltage		—	1.23	—	V
ΔV <sub>REF</sub> /ΔT	V <sub>REF</sub> Temperature Coefficient	Note 2	—	<b>40</b>	—	ppm/°C
ΔV <sub>OUT</sub> /ΔV <sub>IN</sub>	Line Regulation	(V <sub>R</sub> + 1V) ≤ V <sub>IN</sub> ≤ 6V	—	0.05	—	%/V
ΔV <sub>OUT</sub> /V <sub>OUT</sub>	Load Regulation	I <sub>L</sub> = 0.1mA to I <sub>OUTMAX</sub> (Note 3)	—	0.5	—	%
V <sub>IN</sub> - V <sub>OUT</sub>	Dropout Voltage (Note 4)	I <sub>L</sub> = 0.1mA I <sub>L</sub> = 20mA I <sub>L</sub> = 50mA (Note 4)	—	5 65 95	—	mV
I <sub>GND</sub>	Ground Pin Current	I <sub>L</sub> = I <sub>OUTMAX</sub> , (Note 5)	—	<b>0</b>	—	μA
I <sub>IN</sub>	Supply Current	$\overline{\text{SHDN}} = V_{IH}$ , I <sub>L</sub> = 0	—	50	—	μA
I <sub>INSD</sub>	Shutdown Supply Current	$\overline{\text{SHDN}} = 0V$	—	—	0.05	μA
PSRR	Power Supply Rejection Ratio	F <sub>RE</sub> ≤ 1kHz	—	64	—	dB
I <sub>OUTSC</sub>	Output Short Circuit Current	V <sub>OUT</sub> = 0V	—	200	450	mA
ΔV <sub>OUT</sub> /ΔP <sub>D</sub>	Thermal Regulation	Note 6	—	0.04	—	%/W
T <sub>SD</sub>	Thermal Shutdown Die Temperature		—	160	—	°C
ΔT <sub>SD</sub>	Thermal Shutdown Hysteresis		—	10	—	°C
eN	Output Noise	I <sub>L</sub> = I <sub>OUTMAX</sub> 470pF from Bypass to GND	—	260	—	nV/√Hz

**SHDN** Input

V <sub>IH</sub>	$\overline{\text{SHDN}}$ Input High Threshold	V <sub>IN</sub> = 2.5V to 6.5V	45	—	—	%V <sub>IN</sub>
V <sub>IL</sub>	$\overline{\text{SHDN}}$ Input Low Threshold	V <sub>IN</sub> = 2.5V to 6.5V	—	—	15	%V <sub>IN</sub>

**ELECTRICAL CHARACTERISTICS:**  $V_{IN} = V_{OUT} + 1V$ ,  $I_L = 0.1mA$ ,  $C_L = 3.3\mu F$ ,  $\overline{SHDN} > V_{IH}$ ,  $T_A = 25^\circ C$ , unless otherwise noted.

Symbol	Parameter	Test Conditions	Min	Typ	Max	Units
<b>ADJ Input</b>						
$I_{ADJ}$	Adjust Input Leakage Current		—	50	—	pA

- NOTES:**
- $V_R$  is the regulator output voltage setting.
  - $TC V_{OUT} = \frac{(V_{OUTMAX} - V_{OUTMIN}) \times 10^6}{V_{OUT} \times \Delta T}$
  - Regulation is measured at a constant junction temperature using low duty cycle pulse testing. Load regulation is tested over a load range from 0.1mA to the maximum specified output current. Changes in output voltage due to heating effects are covered by the thermal regulation specification.
  - Dropout voltage is defined as the input to output differential at which the output voltage drops 2% below its nominal value.
  - Ground pin current is the regulator pass transistor gate current. The total current drawn from the input supply is the sum of the load current, ground current and supply current (i.e.  $I_{IN} = I_{SUPPLY} + I_{GND} + I_{LOAD}$ ).
  - Thermal Regulation is defined as the change in output voltage at a time T after a change in power dissipation is applied, excluding load or line regulation effects. Specifications are for a current pulse equal to  $I_{LMAX}$  at  $V_{IN} = 6V$  for  $T = 10msec$ .
  - The maximum allowable power dissipation is a function of ambient temperature, the maximum allowable junction temperature and the thermal resistance from junction-to-air (i.e.  $T_A$ ,  $T_J$ ,  $q_{JA}$ ). Exceeding the maximum allowable power dissipation causes the device to initiate thermal shutdown. Please see *Thermal Considerations* section of this data sheet for more details.

## PIN DESCRIPTION

Pin No. (SOT-23A-5)	Symbol	Description
1	$V_{IN}$	Unregulated supply input.
2	GND	Ground terminal.
3	$\overline{SHDN}$	Shutdown control input. The regulator is fully enabled when a logic high is applied to this input. The regulator enters shutdown when a logic low is applied to this input. During shutdown, output voltage falls to zero and supply current is reduced to 0.05 microamp (typical).
4	ADJ	Output voltage adjust terminal. Output voltage setting is programmed with a resistor divider from $V_{OUT}$ to this input. A capacitor may also be added to this input to reduce output noise (See Text).
5	$V_{OUT}$	Regulated voltage output.

## TC1070

## DETAILED DESCRIPTION

The TC1070 is a precision fixed output voltage regulator. (If a fixed version is desired, please see the TC1014 or TC1015 data sheets.) Unlike the bipolar regulators, the TC1070 supply current does not increase with load current. In addition,  $V_{OUT}$  remains stable and within regulation at very low load currents (an important consideration in RTC and CMOS RAM battery back-up applications).

Figure 1 shows a typical application circuit. The regulator is enabled any time the shutdown input (SHDN) is at or above  $V_{IH}$ , and shutdown (disabled) when SHDN is at or below  $V_{IL}$ . SHDN may be controlled by a CMOS logic gate, or I/O port of a microcontroller. If the SHDN input is not required, it should be connected directly to the input supply. While in shutdown, supply current decreases to  $0.05\mu\text{A}$  (typical) and  $V_{OUT}$  falls to zero volts.

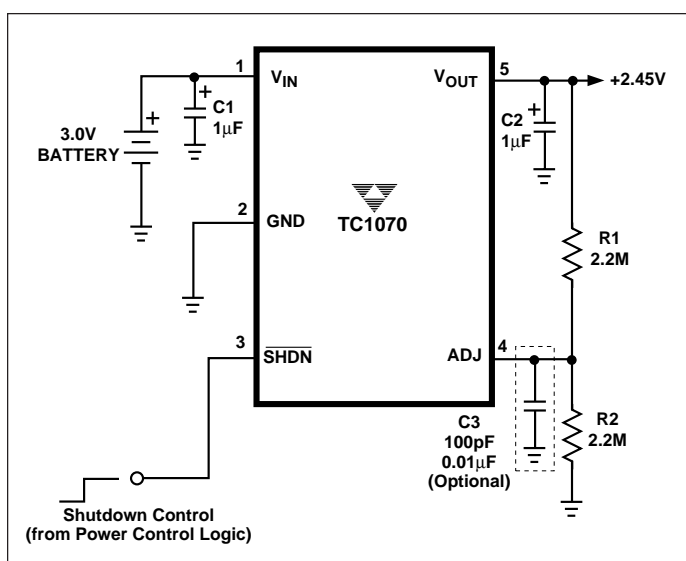

Figure 1. 2.45 Battery-Operated Supply

## Adjust Input

The output voltage setting is determined by the values of  $R_1$  and  $R_2$  (Figure 1). The ohmic values of these resistors should be between 470K and 3M to minimize bleeder current.

The output voltage setting is calculated using the following equation.

$$V_{OUT} = V_{REF} \times \left[ \frac{R_1}{R_2} + 1 \right]$$

Equation 1.

The voltage adjustment range of the TC1070 is from  $V_{REF}$  to  $(V_{IN} - 0.05\text{V})$ . If so desired, a small capacitor (100pF to  $0.01\mu\text{F}$ ) may be added to the ADJ input to further reduce output noise.

## Output Capacitor

A  $1\mu\text{F}$  (min) capacitor from  $V_{OUT}$  to ground is recommended. The output capacitor should have an effective series resistance of  $5\Omega$  or less, and a resonant frequency above 1MHz. A  $1\mu\text{F}$  capacitor should be connected from  $V_{IN}$  to GND if there is more than 10 inches of wire between the regulator and the AC filter capacitor, or if a battery is used as the power source. Aluminum electrolytic or tantalum capacitor types can be used. (Since many aluminum electrolytic capacitors freeze at approximately  $-30^\circ\text{C}$ , solid tantalums are recommended for applications operating below  $-25^\circ\text{C}$ .) When operating from sources other than batteries, supply-noise rejection and transient response can be improved by increasing the value of the input and output capacitors and employing passive filtering techniques.

## Thermal Considerations

## Thermal Shutdown

Integrated thermal protection circuitry shuts the regulator off when die temperature exceeds  $160^\circ\text{C}$ . The regulator remains off until the die temperature drops to approximately  $150^\circ\text{C}$ .

## Power Dissipation

The amount of power the regulator dissipates is primarily a function of input and output voltage, and output current. The following equation is used to calculate worst case *actual* power dissipation:

$$P_D \approx (V_{INMAX} - V_{OUTMIN}) I_{LOADMAX}$$

Where:

$P_D$  = Worst case actual power dissipation

$V_{INMAX}$  = Maximum voltage on  $V_{IN}$

$V_{OUTMIN}$  = Minimum regulator output voltage

$I_{LOADMAX}$  = Maximum output (load) current

Equation 2.

The maximum *allowable* power dissipation (Equation 2) is a function of the maximum ambient temperature ( $T_{AMAX}$ ), the maximum allowable die temperature ( $125^\circ\text{C}$ ) and the thermal resistance from junction-to-air ( $\theta_{JA}$ ). SOT-23A-5 package has a  $\theta_{JA}$  of approximately  $220^\circ\text{C/Watt}$  when mounted on a single layer FR4 dielectric copper clad PC board.

$$P_{D MAX} = \frac{(T_{JMAX} - T_{JMAX})}{\theta_{JA}}$$

Where all terms are previously defined.

Equation 3.

Equation 2 can be used in conjunction with Equation 3 to ensure regulator thermal operation is within limits. For example:

Given:

$$\begin{aligned}V_{INMAX} &= 3.0V \pm 10\% \\V_{OUTMIN} &= 2.7V \pm 0.5V \\I_{LOAD} &= 40mA \\T_{AMAX} &= 55^{\circ}C\end{aligned}$$

Find: 1. Actual power dissipation  
2. Maximum allowable dissipation

Actual power dissipation:

$$\begin{aligned}P_D &\approx (V_{INMAX} - V_{OUTMIN})I_{LOADMAX} \\&= [(3.0 \times 1.05) - (2.7 \times .995)]40 \times 10^{-3} \\&= 18.5mW\end{aligned}$$

Maximum allowable power dissipation:

$$\begin{aligned}P_{DMAX} &= \frac{(T_{JMAX} - T_{AMAX})}{\theta_{JA}} \\&= \frac{(125 - 55)}{220} \\&= 318mW\end{aligned}$$

In this example, the TC1070 dissipates a maximum of only 60mW; far below the allowable limit of 318mW. In a similar manner, Equation 2 and Equation 3 can be used to calculate maximum current and/or input voltage limits.

## Layout Considerations

The primary path of heat conduction out of the package is via the package leads. Therefore, layouts having a ground plane, wide traces at the pads, and wide power supply bus lines combine to lower  $\theta_{JA}$  and therefore increase the maximum allowable power dissipation limit.

TC1070

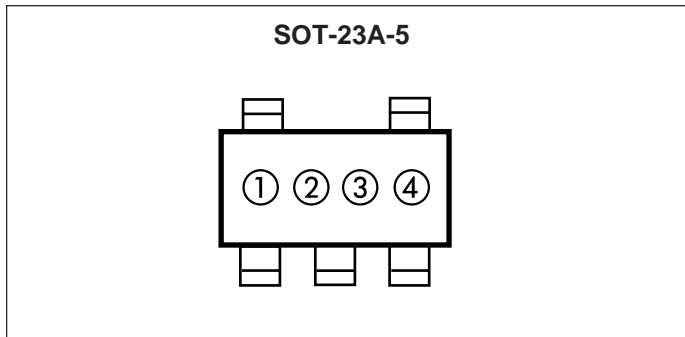

① & ② = part number code + temperature range and voltage

TC1070 (V)	Code
Adjustable	BA

③ represents year and quarter code

④ represents lot ID number

PACKAGE DIMENSIONS

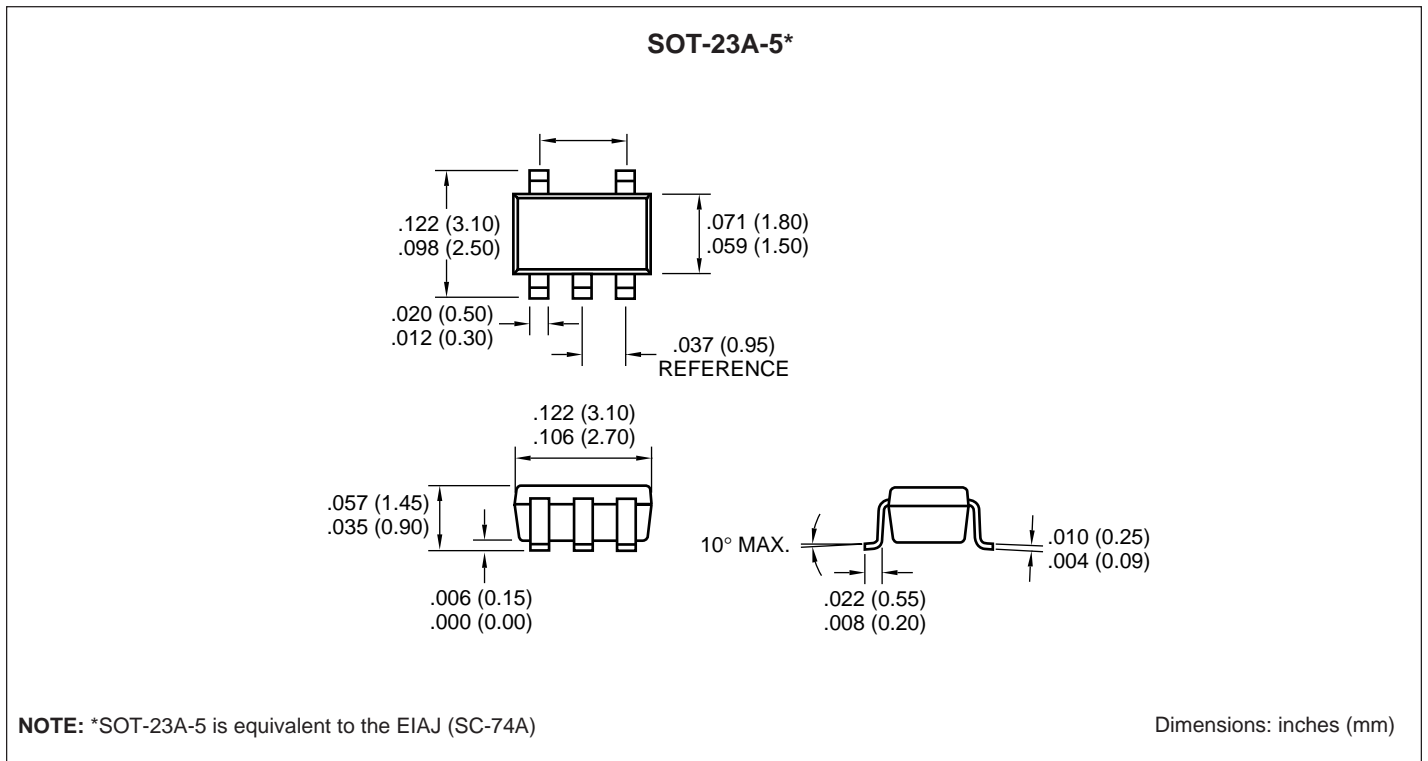

Sales Offices

**TelCom Semiconductor**  
1300 Terra Bella Avenue  
P.O. Box 7267  
Mountain View, CA 94039-7267  
TEL: 415-968-9241  
FAX: 415-967-1590  
E-Mail: liter@c2smtp.telcom-semi.com

**TelCom Semiconductor**  
Austin Product Center  
9101 Burnet Rd. Suite 214  
Austin, TX 78758  
TEL: 512-873-7100  
FAX: 512-873-8236 TelCom

**TelCom Semiconductor H.K. Ltd.**  
10 Sam Chuk Street, 6/F  
San Po Kong  
Kowloon  
Hong Kong  
TEL: 852-2324-0122  
FAX: 852-2354-9957

## 100mA ADJUSTABLE CMOS LDO WITH SHUTDOWN

### FEATURES

- Zero Ground Current for Longer Battery Life!
- Adjustable Output Voltage
- Very Low Dropout Voltage
- Guaranteed 100mA Output
- Power-Saving Shutdown Mode
- Over-Current and Over-Temperature Protection
- Space-Saving SOT-23A-5 Package
- Pin Compatible with LP2980 and MIC5205 Regulators

### APPLICATIONS

- Battery Operated Systems
- Portable Computers
- Medical Instruments
- Instrumentation
- Cellular / GSM / PHS Phones
- Linear Post-Regulator for SMPS
- Pagers

### GENERAL DESCRIPTION

The TC1071 is an adjustable LDO designed to supercede a variety of older (bipolar) voltage regulators. Designed specifically for battery-operated systems, the TC1070's CMOS construction eliminates wasted ground current, significantly extending battery life. Total supply current is typically 50µA at full load (*20 to 60 times lower than in bipolar regulators!*).

TC1071 key features include ultra low noise operation very low dropout voltage (typically 200mV at full load) and internal feed-forward compensation for fast response to step changes in load. Supply current is reduced to less than 1µA when the shutdown input is low. The TC1071 incorporates both over-temperature and over-current protection. Output voltage is programmed with a simple resistor divider from V<sub>OUT</sub> to ADJ.

The TC1071 is stable with an output capacitor of only 1µF and has a maximum output current of 100mA. For higher output versions, please see the TC1174 (I<sub>OUT</sub> = 300mA) data sheet.

### TYPICAL APPLICATION

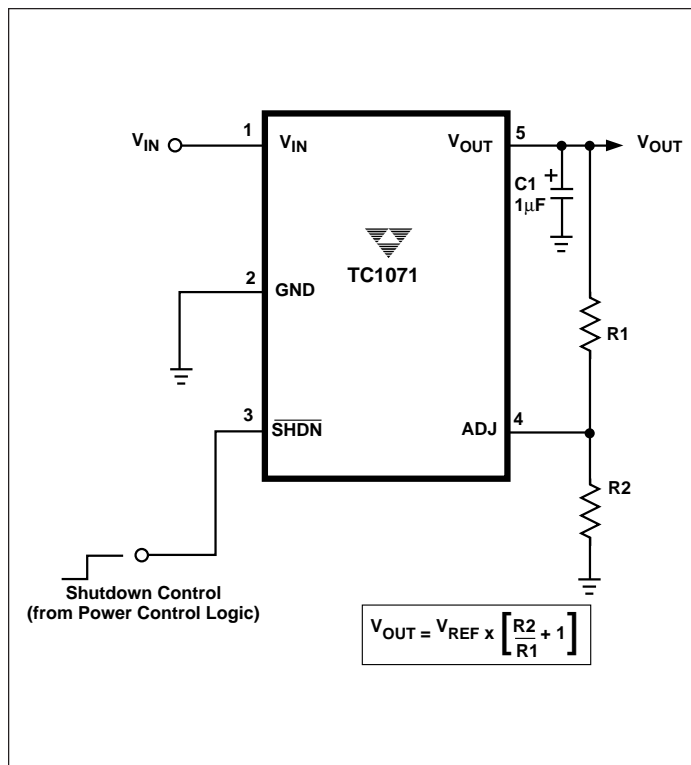

### ORDERING INFORMATION

Part No.	Output Voltage ** (V)	Package	Junction Temp. Range
TC1071VCT	Adjustable	SOT-23A-5*	-40°C to +125°C

NOTE: \*SOT-23A-5 is equivalent to the EIAJ (SC-74A)

\*\*Other output voltages available. Please contact TelCom Semiconductor for details

### PIN CONFIGURATION

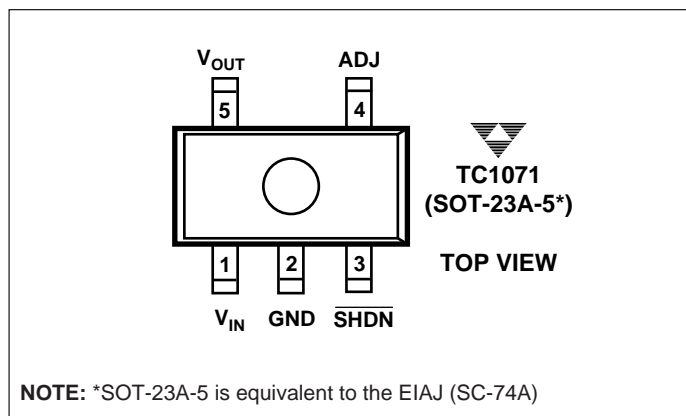

NOTE: \*SOT-23A-5 is equivalent to the EIAJ (SC-74A)

## TC1071

## ABSOLUTE MAXIMUM RATINGS\*

Input Voltage .....	7V
Output Voltage .....	(-0.3) to (V <sub>IN</sub> + 0.3)
Power Dissipation .....	Internally Limited (Note 7)
Operating Temperature .....	-40°C < T <sub>J</sub> < 125°C
Storage Temperature .....	-65°C to +150°C
Maximum Voltage on Any Pin .....	V <sub>IN</sub> + 0.3V to -0.3V
Lead Temperature (Soldering, 10 Sec.) .....	+260°C

\*Stresses beyond those listed under "Absolute Maximum Ratings" may cause permanent damage to the device. These are stress ratings only, and functional operation of the device at these or any other conditions beyond those indicated in the operational sections of the specifications is not implied. Exposure to absolute maximum rating conditions for extended periods may affect device reliability.

**ELECTRICAL CHARACTERISTICS:** V<sub>IN</sub> = V<sub>OUT</sub> + 1V, I<sub>L</sub> = 0.1mA, C<sub>L</sub> = 3.3μF,  $\overline{\text{SHDN}} > V_{IH}$ , T<sub>A</sub> = 25°C, unless otherwise specified. **BOLDFACE** type specifications apply for junction temperatures of -40°C to +125°C.

Symbol	Parameter	Test Conditions	Min	Typ	Max	Units
V <sub>IN</sub>	Input Operating Voltage		—	—	<b>6.5</b>	V
I <sub>OUTMAX</sub>	Maximum Output Current		<b>100</b>	—	—	mA
V <sub>OUT</sub>	Output Voltage	V <sub>REF</sub> ≤ V <sub>OUT</sub> ≤ (V <sub>IN</sub> - 0.05) I <sub>L</sub> = 0 (Note 1)	<b>V<sub>R</sub> - 2.5%</b>	V <sub>R</sub> ±0.5%	<b>V<sub>R</sub> + 2.5%</b>	V
V <sub>REF</sub>	Reference Voltage		—	1.23	—	V
ΔV <sub>REF</sub> /ΔT	V <sub>REF</sub> Temperature Coefficient	Note 2	—	<b>40</b>	—	
ΔV <sub>OUT</sub> /ΔV <sub>IN</sub>	Line Regulation	(V <sub>R</sub> + 1V) ≤ V <sub>IN</sub> ≤ 6V	—	0.05	—	%/V
ΔV <sub>OUT</sub> /V <sub>OUT</sub>	Load Regulation	I <sub>L</sub> = 0.1mA to I <sub>OUTMAX</sub> (Note 3)	—	0.5	—	%
V <sub>IN</sub> - V <sub>OUT</sub>	Dropout Voltage (Note 4)	I <sub>L</sub> = 0.1mA I <sub>L</sub> = 20mA I <sub>L</sub> = 50mA I <sub>L</sub> = 100mA (Note 4)	—	20 70 93 112	—	mV
I <sub>GND</sub>	Ground Pin Current	I <sub>L</sub> = I <sub>OUTMAX</sub> , (Note 5)	—	<b>0</b>	—	μA
I <sub>IN</sub>	Supply Current	$\overline{\text{SHDN}} = V_{IH}$ , I <sub>L</sub> = 0	—	50	—	μA
I <sub>INSD</sub>	Shutdown Supply Current	$\overline{\text{SHDN}} = 0V$	—	—	0.05	μA
PSRR	Power Supply Rejection Ratio	F <sub>RE</sub> ≤ 1kHz	—	64	—	dB
I <sub>OUTSC</sub>	Output Short Circuit Current	V <sub>OUT</sub> = 0V	—	300	450	mA
ΔV <sub>OUT</sub> /ΔP <sub>D</sub>	Thermal Regulation	Note 6	—	0.04	—	%/W
eN	Output Noise	I <sub>L</sub> = I <sub>OUTMAX</sub> 470pF from Bypass to GND	—	260	—	nV/√Hz

**SHDN Input**

V <sub>IH</sub>	$\overline{\text{SHDN}}$ Input High Threshold	V <sub>IN</sub> = 2.5V to 6.5V	45	—	—	%V <sub>IN</sub>
V <sub>IL</sub>	$\overline{\text{SHDN}}$ Input Low Threshold	V <sub>IN</sub> = 2.5V to 6.5V	—	—	15	%V <sub>IN</sub>

**ELECTRICAL CHARACTERISTICS:**  $V_{IN} = V_{OUT} + 1V$ ,  $I_L = 0.1mA$ ,  $C_L = 3.3\mu F$ ,  $\overline{SHDN} > V_{IH}$ ,  $T_A = 25^\circ C$ , unless otherwise noted.

Symbol	Parameter	Test Conditions	Min	Typ	Max	Units
<b>ADJ Input</b>						
$I_{ADJ}$	Adjust Input Leakage Current		—	50	—	pA

- NOTES:**
- $V_R$  is the regulator output voltage setting.
  - $TC V_{OUT} = \frac{(V_{OUTMAX} - V_{OUTMIN}) \times 10^6}{V_{OUT} \times \Delta T}$
  - Regulation is measured at a constant junction temperature using low duty cycle pulse testing. Load regulation is tested over a load range from 0.1mA to the maximum specified output current. Changes in output voltage due to heating effects are covered by the thermal regulation specification.
  - Dropout voltage is defined as the input to output differential at which the output voltage drops 2% below its nominal value.
  - Ground pin current is the regulator pass transistor gate current. The total current drawn from the input supply is the sum of the load current, ground current and supply current (i.e.  $I_{IN} = I_{SUPPLY} + I_{GND} + I_{LOAD}$ ).
  - Thermal Regulation is defined as the change in output voltage at a time T after a change in power dissipation is applied, excluding load or line regulation effects. Specifications are for a current pulse equal to  $I_{LMAX}$  at  $V_{IN} = 6V$  for  $T = 10msec$ .
  - The maximum allowable power dissipation is a function of ambient temperature, the maximum allowable junction temperature and the thermal resistance from junction-to-air (i.e.  $T_A$ ,  $T_J$ ,  $q_{JA}$ ). Exceeding the maximum allowable power dissipation causes the device to initiate thermal shutdown. Please see *Thermal Considerations* section of this data sheet for more details.

## PIN DESCRIPTION

Pin No. (SOT-23A-5)	Symbol	Description
1	$V_{IN}$	Unregulated supply input.
2	GND	Ground terminal.
3	SHDN	Shutdown control input. The regulator is fully enabled when a logic high is applied to this input. The regulator enters shutdown when a logic low is applied to this input. During shutdown, output voltage falls to zero and supply current is reduced to 0.05 microamp (typical).
4	ADJ	Output voltage adjust terminal. Output voltage setting is programmed with a resistor divider from $V_{OUT}$ to this input. A capacitor may also be added to this input to reduce output noise (See Text).
5	$V_{OUT}$	Regulated voltage output.

## TC1071

## DETAILED DESCRIPTION

The TC1071 is a precision fixed output voltage regulator. (If a fixed version is desired, please see the TC1014 or TC1015 data sheets.) Unlike the bipolar regulators, the TC1071 supply current does not increase with load current. In addition,  $V_{OUT}$  remains stable and within regulation at very low load currents (an important consideration in RTC and CMOS RAM battery back-up applications).

Figure 1 shows a typical application circuit. The regulator is enabled any time the shutdown input (SHDN) is at or above  $V_{IH}$ , and shutdown (disabled) when SHDN is at or below  $V_{IL}$ . SHDN may be controlled by a CMOS logic gate, or I/O port of a microcontroller. If the SHDN input is not required, it should be connected directly to the input supply. While in shutdown, supply current decreases to  $0.05\mu\text{A}$  (typical) and  $V_{OUT}$  falls to zero volts.

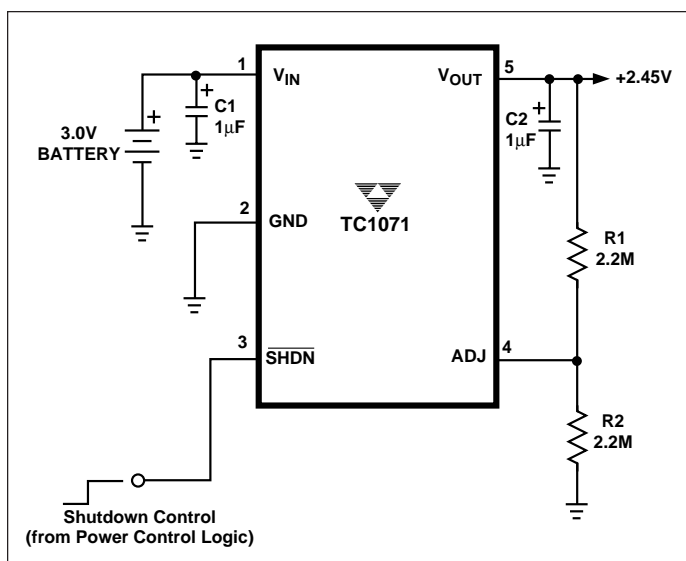

Figure 1. 2.45 Battery-Operated Supply

## Adjust Input

The output voltage setting is determined by the values of R1 and R2 (Figure 1). The ohmic values of these resistors should be between 470K and 3M to minimize bleeder current.

The output voltage setting is calculated using the following equation.

$$V_{OUT} = V_{REF} \times \left[ \frac{R1}{R2} + 1 \right]$$

Equation 1.

The voltage adjustment range of the TC1071 is from  $V_{REF}$  to  $(V_{IN} - 0.05\text{V})$ . If so desired, a small capacitor (100pF to  $0.01\mu\text{F}$ ) may be added to the ADJ input to further reduce output noise.

## Output Capacitor

A  $1\mu\text{F}$  (min) capacitor from  $V_{OUT}$  to ground is recommended. The output capacitor should have an effective series resistance of  $5\Omega$  or less, and a resonant frequency above 1MHz. A  $1\mu\text{F}$  capacitor should be connected from  $V_{IN}$  to GND if there is more than 10 inches of wire between the regulator and the AC filter capacitor, or if a battery is used as the power source. Aluminum electrolytic or tantalum capacitor types can be used. (Since many aluminum electrolytic capacitors freeze at approximately  $-30^\circ\text{C}$ , solid tantalums are recommended for applications operating below  $-25^\circ\text{C}$ .) When operating from sources other than batteries, supply-noise rejection and transient response can be improved by increasing the value of the input and output capacitors and employing passive filtering techniques.

## Thermal Considerations

## Thermal Shutdown

Integrated thermal protection circuitry shuts the regulator off when die temperature exceeds  $160^\circ\text{C}$ . The regulator remains off until the die temperature drops to approximately  $150^\circ\text{C}$ .

## Power Dissipation

The amount of power the regulator dissipates is primarily a function of input and output voltage, and output current. The following equation is used to calculate worst case *actual* power dissipation:

$$P_D \approx (V_{INMAX} - V_{OUTMIN}) I_{LOADMAX}$$

Where:

$P_D$  = Worst case actual power dissipation

$V_{INMAX}$  = Maximum voltage on  $V_{IN}$

$V_{OUTMIN}$  = Minimum regulator output voltage

$I_{LOADMAX}$  = Maximum output (load) current

Equation 2.

The maximum *allowable* power dissipation (Equation 3) is a function of the maximum ambient temperature ( $T_{AMAX}$ ), the maximum allowable die temperature ( $125^\circ\text{C}$ ) and the thermal resistance from junction-to-air ( $\theta_{JA}$ ). SOT-23A-5 package has a  $\theta_{JA}$  of approximately  $220^\circ\text{C/Watt}$  when mounted on a single layer FR4 dielectric copper clad PC board.

$$P_{D MAX} = \frac{(T_{JMAX} - T_{AMAX})}{\theta_{JA}}$$

Where all terms are previously defined.

Equation 3.

Equation 2 can be used in conjunction with Equation 3 to ensure regulator thermal operation is within limits. For example:

Given:

$$\begin{aligned}V_{INMAX} &= 3.0V \pm 10\% \\V_{OUTMIN} &= 2.7V \pm 0.5V \\I_{LOAD} &= 98mA \\T_{AMAX} &= 55^{\circ}C\end{aligned}$$

Find: 1. Actual power dissipation  
2. Maximum allowable dissipation

Actual power dissipation:

$$\begin{aligned}P_D &\approx (V_{INMAX} - V_{OUTMIN})I_{LOADMAX} \\&= [(3.0 \times 1.1) - (2.7 \times .995)]40 \times 10^{-3} \\&= 60mW\end{aligned}$$

Maximum allowable power dissipation:

$$\begin{aligned}P_{DMAX} &= \frac{(T_{JMAX} - T_{AMAX})}{\theta_{JA}} \\&= \frac{(125 - 55)}{220} \\&= 318mW\end{aligned}$$

In this example, the TC1071 dissipates a maximum of only 60mW; far below the allowable limit of 318mW. In a similar manner, Equation 1 and Equation 2 can be used to calculate maximum current and/or input voltage limits. For example, the maximum allowable  $V_{IN}$  is found by substituting the maximum allowable power dissipation of 318mW into Equation 1, from which  $V_{INMAX} = 5.9V$ .

## Layout Considerations

The primary path of heat conduction out of the package is via the package leads. Therefore, layouts having a ground plane, wide traces at the pads, and wide power supply bus lines combine to lower  $\theta_{JA}$  and therefore increase the maximum allowable power dissipation limit.

TC1071

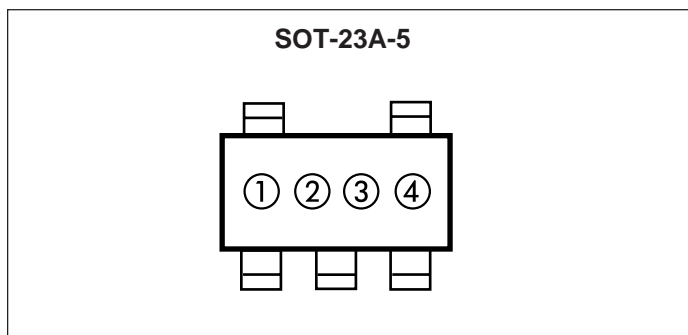

① & ② = part number code + temperature range and voltage

TC1071 (V)	Code
Adjustable	BB

③ represents year and quarter code

④ represents lot ID number

PACKAGE DIMENSIONS

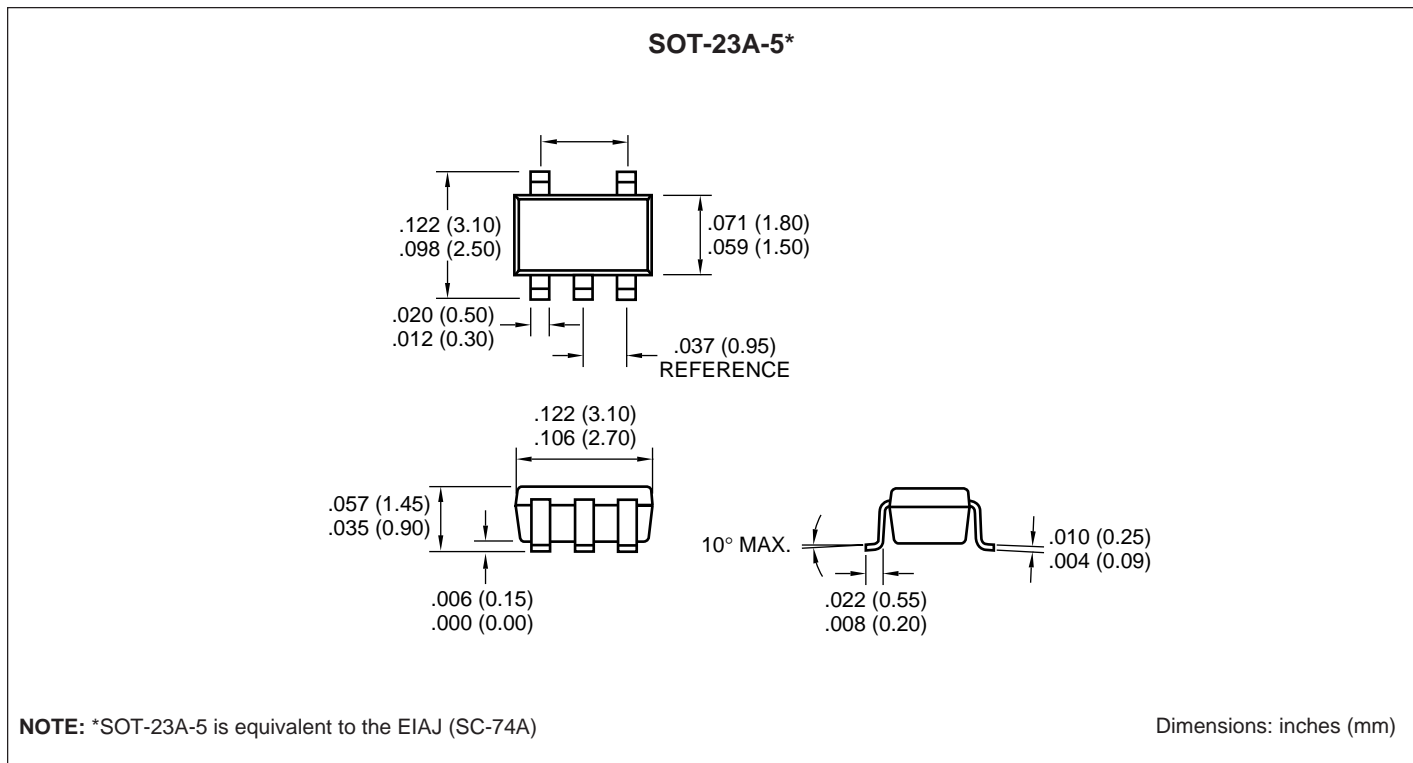

Sales Offices

**TelCom Semiconductor**  
1300 Terra Bella Avenue  
P.O. Box 7267  
Mountain View, CA 94039-7267  
TEL: 415-968-9241  
FAX: 415-967-1590  
E-Mail: liter@c2smtp.telcom-semi.com

**TelCom Semiconductor**  
Austin Product Center  
9101 Burnet Rd. Suite 214  
Austin, TX 78758  
TEL: 512-873-7100  
FAX: 512-873-8236 TelCom

**TelCom Semiconductor H.K. Ltd.**  
10 Sam Chuk Street, 6/F  
San Po Kong  
Kowloon  
Hong Kong  
TEL: 852-2324-0122  
FAX: 852-2354-9957