

Description

The S52xxM is a u-cap 150mA linear voltage regulator in the SOT-25 package. This regulator has very low dropout voltage and very low ground current. It is designed especially for hand-sets, battery-powered devices and can be controlled by a CMOS or TTL. When the S52xxM is disabled, power consumption drops to nearly zero.

Features

- Output current of 150 mA
- Low quiescent current
- Low dropout voltage
- Current limit protection
- Logic-controlled electronic enable

Ordering Information

Type NO.	Marking	Package Code
S52xxM	5□□	SOT - 25

□□: Voltage Code

Outline Dimensions (Unit : mm)

BLOCK DIAGRAM

PIN Connections

1. Input voltage
2. Ground
3. Control
4. Noise bypass
5. Output voltage

Absolute Maximum Ratings

Ta=25°C

Characteristic	Symbol	Rating	Unit
Input Voltage	V _I	16	V
Control Voltage	V _{CT}	16	V
Power Dissipation	P _D (Note1)	500	mW
	P _D (Note2)	150	
Junction Temperature	T _J	150	°C
Storage Temperature Range	T _{stg}	-55 ~ +150	°C

Note 1 : Mount on a glass epoxy circuit board of 30x30mm Pad dimension of 50mm²

Note 2 : No Heat sink

Device Selection Guide

Device	Output Voltage
S5215M	1.5V
S5218M	1.8V
S5225M	2.5V
S5228M	2.8V
S5230M	3.0V
S5233M	3.3V
S5250M	5.0V

Electrical Characteristics

(Electrical characteristics at $V_I=V_O+1V$, $I_O=100\ \mu A$, $C_O=4.7\ \mu F$, $V_{CT}\geq 2.0V$, $T_J=25^\circ C$, unless otherwise specified.)

Characteristic	Symbol	Device	Test Condition	Min	Typ	Max	Unit
Output Voltage	V_O	S5215M	$V_I=(V_O+1V)$, $I_O=100\ \mu A$	1.440	1.5	1.560	V
		S5218M	$V_I=(V_O+1V)$, $I_O=100\ \mu A$	1.728	1.8	1.872	
		S5225M	$V_I=(V_O+1V)$, $I_O=100\ \mu A$	2.400	2.5	2.600	
		S5228M	$V_I=(V_O+1V)$, $I_O=100\ \mu A$	2.688	2.8	2.912	
		S5230M	$V_I=(V_O+1V)$, $I_O=100\ \mu A$	2.880	3.0	3.120	
		S5233M	$V_I=(V_O+1V)$, $I_O=100\ \mu A$	3.168	3.3	3.432	
		S5250M	$V_I=(V_O+1V)$, $I_O=100\ \mu A$	4.800	5.0	5.200	
Line Regulation	$\Delta V_{O(\Delta V_I)}$	All	$1V \leq V_I - V_O \leq 10V$ $I_O=100\ \mu A$	-	0.3	5	mV
Load Regulation (Note3)	$\Delta V_{O(\Delta I_L)}$	All	$V_I=V_O+1V$ $I_O=100\ \mu A \sim 150\ mA$	-	8	24	mV
Standby Current	$I_{I(standby)}$	All	$V_{CT}\leq 0.4V$ (Shutdown)	-	0.01	1	μA
Quiescent Current (Note4)	I_{QC}	S5215M S5218M	$I_O=50\ mA$ $V_{CT}\geq 2.0V$	-	1.5	3.0	mA
		S5225M S5228M S5230M S5233M S5250M	$I_O=50\ mA$ $V_{CT}\geq 2.0V$	-	0.8	1.5	mA
Dropout Voltage (Note5)	V_{DROP}	S5215M	$I_O=100\ mA$	-	400	500	mV
		S5218M	$I_O=100\ mA$	-	500	600	mV
		S5225M S5228M S5230M S5233M S5250M	$I_O=100\ mA$	-	140	250	mV
Control Voltage (ON)	$V_{CT(ON)}$	All	-	1.6	-	V_I	V
Control Voltage (OFF)	$V_{CT(OFF)}$	All	-	-	-	0.4	V
Control Current (ON)	$I_{CT(ON)}$	All	$V_{CT}\geq 2.0V$	2	5	10	μA
Control Current (OFF)	$I_{CT(OFF)}$	All	$V_{CT}\leq 0.4V$	-	0.01	1	μA

Note 3 : Regulation is measured at constant junction temperature using low duty cycle pulse testing.

Parts are tested for load regulation in the load range from 0.1 mA to 150 mA.

Note 4 : Quiescent current is the regulator standby current plus pass transistor base current.

The total current drawn from the supply is the sum of the load current plus the quiescent current.

Note 5 : Dropout voltage is defined as the input to output differential at which the output voltage

Drops 2% below its nominal value measured at 1V differential.

■ Typical Application

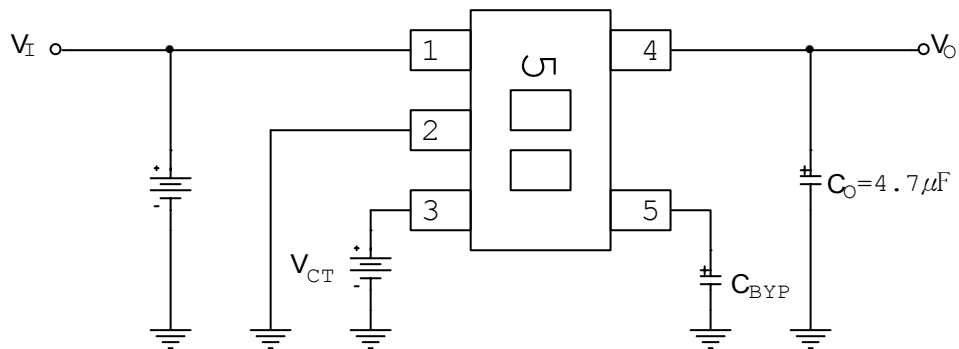

Low- Noise Operation

: $C_{BYP}=470 \text{ pF}$, $C_O \geq 4.7 \text{ } \mu\text{F}$

Basic Operation

: $C_{BYP}=\text{not used}$, $C_O \geq 1 \text{ } \mu\text{F}$

Fig. 1 Fixed Voltage Regulator

Electrical Characteristic Curves (Continue)

Fig. 2 V_{DROD} vs. I_o

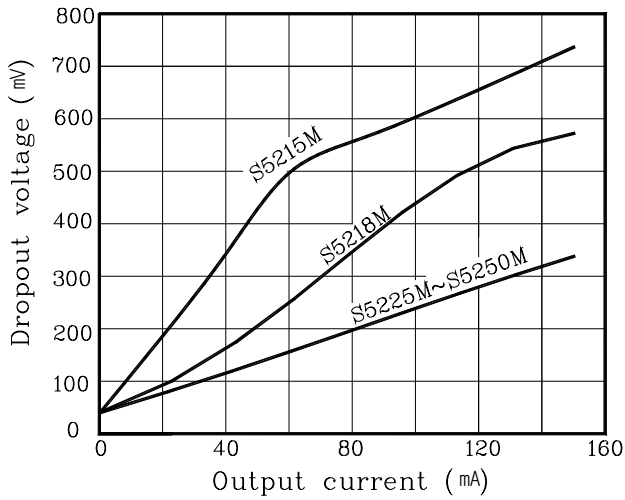

Fig. 3 PSRR vs. Frequency

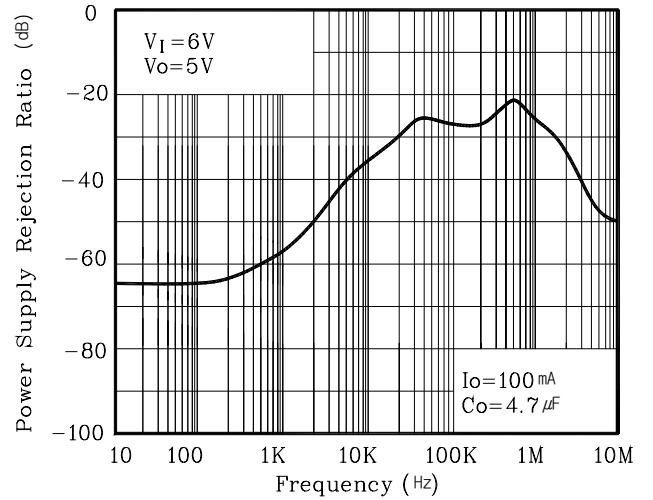

Fig. 4 Turn On Time vs. C_{BYP}

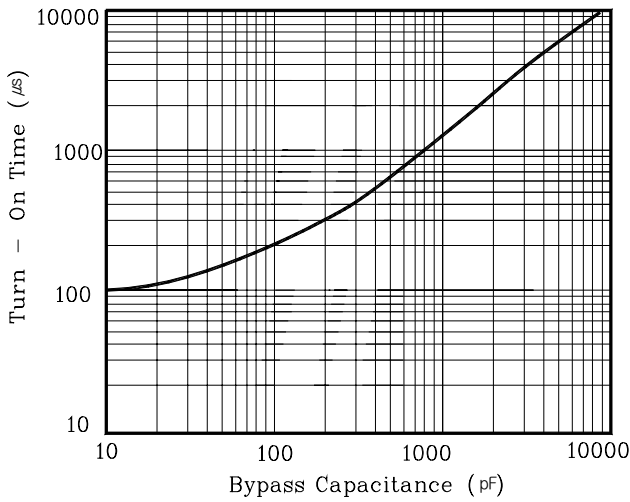

Fig. 5 PSRR vs. V_{DROD}

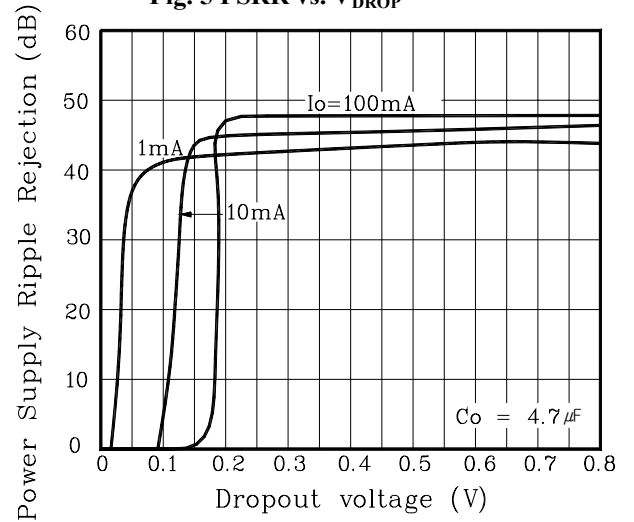

Fig. 6 Noise vs. I_o

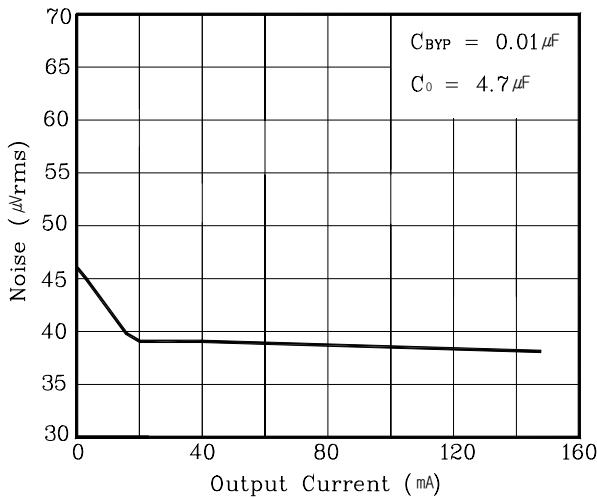
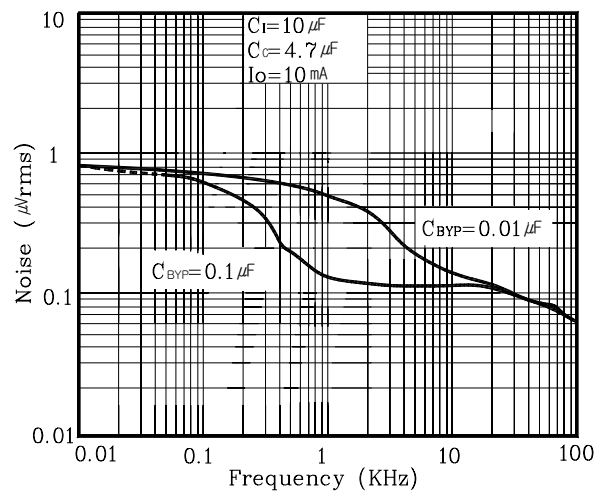

Fig. 7 Noise vs. Frequency



Electrical Characteristic Curves

Fig. 8 V_O vs. Time

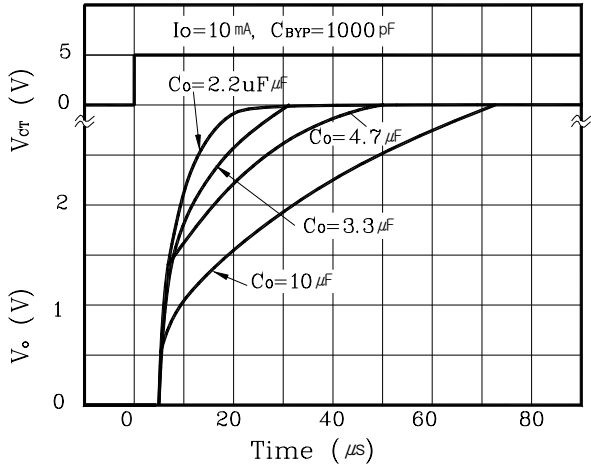

Fig. 9 V_O vs. Time

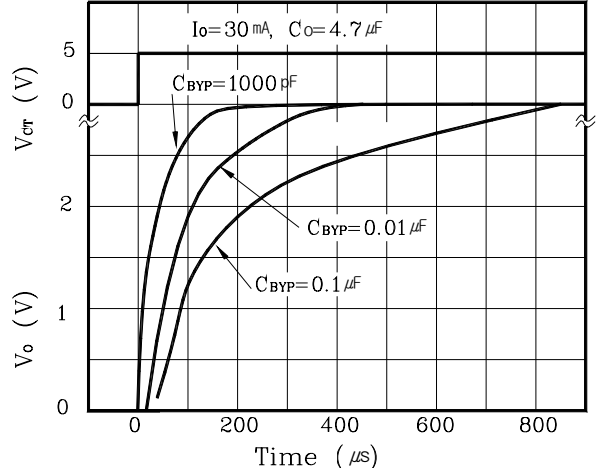
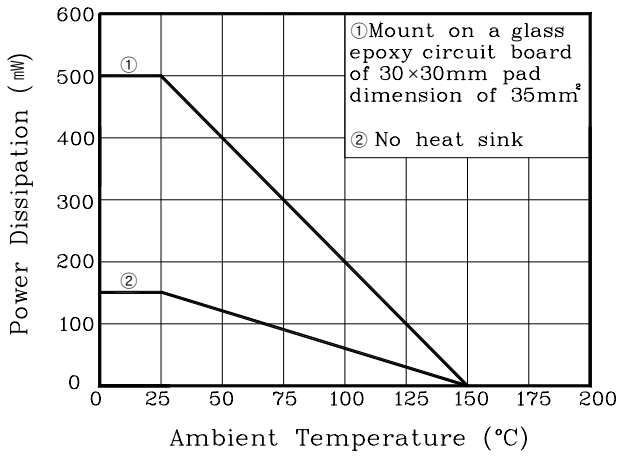

Fig. 10 P_D vs. T_a



These AUK products are intended for usage in general electronic equipments(Office and communication equipment, measuring equipment, domestic electrification, etc.).

Please make sure that you consult with us before you use these AUK products in equipments which require high quality and/or reliability, and in equipments which could have major impact to the welfare of human life(atomic energy control, airplane, spaceship, traffic signal, combustion central, all types of safety device, etc.).

AUK cannot accept liability to any damage which may occur in case these AUK products were used in the mentioned equipments without prior consultation with AUK.