

PRELIMINARY DATASHEET

DATASHEET

PRODUCT : 64M (x16) Flash Memory

MODEL No : **LH28F640BFN-PTTLZ2**

- This device datasheet is subject to change without notice.
- Copyright Sharp Co., Ltd. All rights reserved. No reproduction or republication without written permission.
- Contact your local Sharp sales office to obtain the latest datasheet.

LHF64FZ2

- Handle this document carefully for it contains material protected by international copyright law. Any reproduction, full or in part, of this material is prohibited without the express written permission of the company.
- When using the products covered herein, please observe the conditions written herein and the precautions outlined in the following paragraphs. In no event shall the company be liable for any damages resulting from failure to strictly adhere to these conditions and precautions.
 - (1) The products covered herein are designed and manufactured for the following application areas. When using the products covered herein for the equipment listed in Paragraph (2), even for the following application areas, be sure to observe the precautions given in Paragraph (2). Never use the products for the equipment listed in Paragraph (3).
 - Office electronics
 - Instrumentation and measuring equipment
 - Machine tools
 - Audiovisual equipment
 - Home appliance
 - Communication equipment other than for trunk lines
 - (2) Those contemplating using the products covered herein for the following equipment which demands high reliability, should first contact a sales representative of the company and then accept responsibility for incorporating into the design fail-safe operation, redundancy, and other appropriate measures for ensuring reliability and safety of the equipment and the overall system.
 - Control and safety devices for airplanes, trains, automobiles, and other transportation equipment
 - Mainframe computers
 - Traffic control systems
 - Gas leak detectors and automatic cutoff devices
 - Rescue and security equipment
 - Other safety devices and safety equipment, etc.
 - (3) Do not use the products covered herein for the following equipment which demands extremely high performance in terms of functionality, reliability, or accuracy.
 - Aerospace equipment
 - Communications equipment for trunk lines
 - Control equipment for the nuclear power industry
 - Medical equipment related to life support, etc.
 - (4) Please direct all queries and comments regarding the interpretation of the above three Paragraphs to a sales representative of the company.
- Please direct all queries regarding the products covered herein to a sales representative of the company.

CONTENTS

PAGE	PAGE		
44-Lead SOP Pinout.....	3	1 Electrical Specifications.....	14
Pin Descriptions.....	4	1.1 Absolute Maximum Ratings	14
Memory Map.....	5	1.2 Operating Conditions	14
Identifier Codes and OTP Address for Read Operation	6	1.2.1 Capacitance	15
OTP Block Address Map for OTP Program.....	7	1.2.2 AC Input/Output Test Conditions	15
Bus Operation.....	8	1.2.3 DC Characteristics	16
Command Definitions	9	1.2.4 AC Characteristics - Read-Only Operations.....	17
Functions of Block Lock and Block Lock-Down.....	11	1.2.5 AC Characteristics - Write Operations	20
Block Locking State Transitions upon Command Write.....	11	1.2.6 Reset Operations	22
Status Register Definition.....	12	1.2.7 Block Erase, Full Chip Erase, (Page Buffer) Program and OTP Program Performance.....	23
Extended Status Register Definition	13	2 Related Document Information.....	24

LH28F640BFN-PTTLZ2

64Mbit (4Mbit×16)

Page Mode Flash MEMORY

- 64M density with 16Bit I/O Interface
- High Performance Reads
 - 90/35ns 8-Word Page Mode
- Low Power Operation
 - 2.7V Read and Write Operations
 - Automatic Power Savings Mode Reduces I_{CCR} in Static Mode
- Enhanced Code + Data Storage
 - 5 μ s Typical Erase/Program Suspends
- OTP (One Time Program) Block
 - 4-Word Factory-Programmed Area
 - 4-Word User-Programmable Area
- High Performance Program with Page Buffer
 - 16-Word Page Buffer
- Operating Temperature 0°C to +70°C
- Flexible Blocking Architecture
 - Eight 4K-word Parameter Blocks
 - One-hundred and twenty-seven 32K-word Main Blocks
 - Top Parameter Location
- CMOS Process (P-type silicon substrate)
- Enhanced Data Protection Features
 - Individual Block Lock and Block Lock-Down with Zero-Latency
 - All blocks are locked at power-up or device reset.
 - Block Erase, Full Chip Erase, (Page Buffer) Word Program Lockout during Power Transitions
- Automated Erase/Program Algorithms
 - 3.0V Low-Power 11 μ s/Word (Typ.) Programming
- Cross-Compatible Command Support
 - Basic Command Set
 - Common Flash Interface (CFI)
- Extended Cycling Capability
 - Minimum 100,000 Block Erase Cycles
- 44-Lead SOP
- ETOX™* Flash Technology
- Not designed or rated as radiation hardened

The product, which is Page Mode Flash memory, is a low power, high density, low cost, nonvolatile read/write storage solution for a wide range of applications. The product can operate at $V_{CC}=2.7V-3.6V$. Its low voltage operation capability greatly extends battery life for portable applications.

The product provides high performance asynchronous page mode. It allows code execution directly from Flash, thus eliminating time consuming wait states.

The memory array block architecture utilizes Enhanced Data Protection features, and provides separate Parameter and Main Blocks that provide maximum flexibility for safe nonvolatile code and data storage.

Fast program capability is provided through the use of high speed Page Buffer Program.

Special OTP (One Time Program) block provides an area to store permanent code such as a unique number.

* ETOX is a trademark of Intel Corporation.

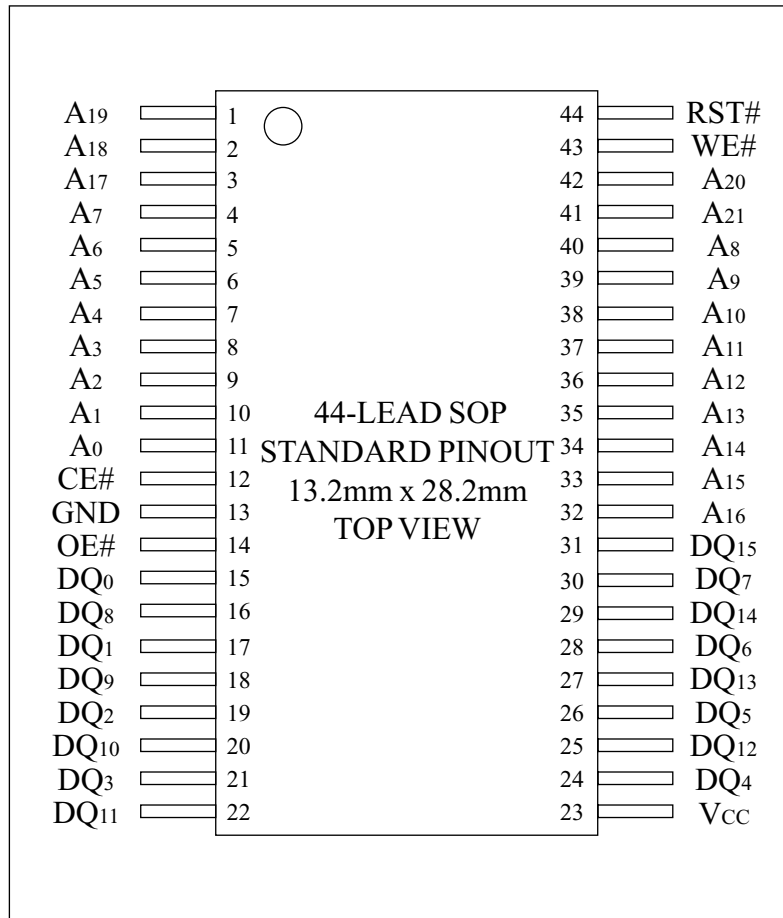

Figure 1. 44-Lead SOP Pinout

Table 1. Pin Descriptions

Symbol	Type	Name and Function
A ₀ -A ₂₁	INPUT	ADDRESS INPUTS: Inputs for addresses. 64M: A ₀ -A ₂₁
DQ ₀ -DQ ₁₅	INPUT/ OUTPUT	DATA INPUTS/OUTPUTS: Inputs data and commands during CUI (Command User Interface) write cycles, outputs data during memory array, status register, query code and identifier code reads. Data pins float to high-impedance (High Z) when the chip or outputs are deselected. Data is internally latched during an erase or program cycle.
CE#	INPUT	CHIP ENABLE: Activates the device's control logic, input buffers, decoders and sense amplifiers. CE#-high (V _{IH}) deselected the device and reduces power consumption to standby levels.
RST#	INPUT	RESET: When low (V _{IL}), RST# resets internal automation and inhibits write operations which provides data protection. RST#-high (V _{IH}) enables normal operation. After power-up or reset mode, the device is automatically set to read array mode. RST# must be low during power-up/down.
OE#	INPUT	OUTPUT ENABLE: Gates the device's outputs during a read cycle.
WE#	INPUT	WRITE ENABLE: Controls writes to the CUI and array blocks. Addresses and data are latched on the rising edge of CE# or WE# (whichever goes high first).
V _{CC}	SUPPLY	DEVICE POWER SUPPLY (2.7V-3.6V): With V _{CC} ≤ V _{LKO} , all write attempts to the flash memory are inhibited. Device operations at invalid V _{CC} voltage (see DC Characteristics) produce spurious results and should not be attempted.
GND	SUPPLY	GROUND: Do not float any ground pins.

BLOCK NUMBER ADDRESS RANGE

134	4K-WORD	3FF000H - 3FFFFFFH
133	4K-WORD	3FE000H - 3FEFFFH
132	4K-WORD	3FD000H - 3FDFFFH
131	4K-WORD	3FC000H - 3FCFFFH
130	4K-WORD	3FB000H - 3FBFFFH
129	4K-WORD	3FA000H - 3FAFFFH
128	4K-WORD	3F9000H - 3F9FFFH
127	4K-WORD	3F8000H - 3F8FFFH
126	32K-WORD	3F0000H - 3F7FFFH
125	32K-WORD	3E8000H - 3EFFFFH
124	32K-WORD	3E0000H - 3E7FFFH
123	32K-WORD	3D8000H - 3DFFFFH
122	32K-WORD	3D0000H - 3D7FFFH
121	32K-WORD	3C8000H - 3CFFFFH
120	32K-WORD	3C0000H - 3C7FFFH
119	32K-WORD	3B8000H - 3BFFFFH
118	32K-WORD	3B0000H - 3B7FFFH
117	32K-WORD	3A8000H - 3AFFFFH
116	32K-WORD	3A0000H - 3A7FFFH
115	32K-WORD	398000H - 39FFFFH
114	32K-WORD	390000H - 397FFFH
113	32K-WORD	388000H - 38FFFFH
112	32K-WORD	380000H - 387FFFH
111	32K-WORD	378000H - 37FFFFH
110	32K-WORD	370000H - 377FFFH
109	32K-WORD	368000H - 36FFFFH
108	32K-WORD	360000H - 367FFFH
107	32K-WORD	358000H - 35FFFFH
106	32K-WORD	350000H - 357FFFH
105	32K-WORD	348000H - 34FFFFH
104	32K-WORD	340000H - 347FFFH
103	32K-WORD	338000H - 33FFFFH
102	32K-WORD	330000H - 337FFFH
101	32K-WORD	328000H - 32FFFFH
100	32K-WORD	320000H - 327FFFH
99	32K-WORD	318000H - 31FFFFH
98	32K-WORD	310000H - 317FFFH
97	32K-WORD	308000H - 30FFFFH
96	32K-WORD	300000H - 307FFFH
95	32K-WORD	2F8000H - 2FFFFFFH
94	32K-WORD	2F0000H - 2F7FFFH
93	32K-WORD	2E8000H - 2EFFFFH
92	32K-WORD	2E0000H - 2E7FFFH
91	32K-WORD	2D8000H - 2DFFFFH
90	32K-WORD	2D0000H - 2D7FFFH
89	32K-WORD	2C8000H - 2CFFFFH
88	32K-WORD	2C0000H - 2C7FFFH
87	32K-WORD	2B8000H - 2BFFFFH
86	32K-WORD	2B0000H - 2B7FFFH
85	32K-WORD	2A8000H - 2AFFFFH
84	32K-WORD	2A0000H - 2A7FFFH
83	32K-WORD	298000H - 29FFFFH
82	32K-WORD	290000H - 297FFFH
81	32K-WORD	288000H - 28FFFFH
80	32K-WORD	280000H - 287FFFH
79	32K-WORD	278000H - 27FFFFH
78	32K-WORD	270000H - 277FFFH
77	32K-WORD	268000H - 26FFFFH
76	32K-WORD	260000H - 267FFFH
75	32K-WORD	258000H - 25FFFFH
74	32K-WORD	250000H - 257FFFH
73	32K-WORD	248000H - 24FFFFH
72	32K-WORD	240000H - 247FFFH
71	32K-WORD	238000H - 23FFFFH
70	32K-WORD	230000H - 237FFFH
69	32K-WORD	228000H - 22FFFFH
68	32K-WORD	220000H - 227FFFH
67	32K-WORD	218000H - 21FFFFH
66	32K-WORD	210000H - 217FFFH
65	32K-WORD	208000H - 20FFFFH
64	32K-WORD	200000H - 207FFFH

BLOCK NUMBER ADDRESS RANGE

63	32K-WORD	1F8000H - 1FFFFFFH
62	32K-WORD	1F0000H - 1F7FFFH
61	32K-WORD	1E8000H - 1EFFFFH
60	32K-WORD	1E0000H - 1E7FFFH
59	32K-WORD	1D8000H - 1DFFFFH
58	32K-WORD	1D0000H - 1D7FFFH
57	32K-WORD	1C8000H - 1CFFFFH
56	32K-WORD	1C0000H - 1C7FFFH
55	32K-WORD	1B8000H - 1BFFFFH
54	32K-WORD	1B0000H - 1B7FFFH
53	32K-WORD	1A8000H - 1AFFFFH
52	32K-WORD	1A0000H - 1A7FFFH
51	32K-WORD	198000H - 19FFFFH
50	32K-WORD	190000H - 197FFFH
49	32K-WORD	188000H - 18FFFFH
48	32K-WORD	180000H - 187FFFH
47	32K-WORD	178000H - 17FFFFH
46	32K-WORD	170000H - 177FFFH
45	32K-WORD	168000H - 16FFFFH
44	32K-WORD	160000H - 167FFFH
43	32K-WORD	158000H - 15FFFFH
42	32K-WORD	150000H - 157FFFH
41	32K-WORD	148000H - 14FFFFH
40	32K-WORD	140000H - 147FFFH
39	32K-WORD	138000H - 13FFFFH
38	32K-WORD	130000H - 137FFFH
37	32K-WORD	128000H - 12FFFFH
36	32K-WORD	120000H - 127FFFH
35	32K-WORD	118000H - 11FFFFH
34	32K-WORD	110000H - 117FFFH
33	32K-WORD	108000H - 10FFFFH
32	32K-WORD	100000H - 107FFFH
31	32K-WORD	0F8000H - 0FFFFFFH
30	32K-WORD	0F0000H - 0F7FFFH
29	32K-WORD	0E8000H - 0EFFFFH
28	32K-WORD	0E0000H - 0E7FFFH
27	32K-WORD	0D8000H - 0DFFFFH
26	32K-WORD	0D0000H - 0D7FFFH
25	32K-WORD	0C8000H - 0CFFFFH
24	32K-WORD	0C0000H - 0C7FFFH
23	32K-WORD	0B8000H - 0BFFFFH
22	32K-WORD	0B0000H - 0B7FFFH
21	32K-WORD	0A8000H - 0AFFFFH
20	32K-WORD	0A0000H - 0A7FFFH
19	32K-WORD	098000H - 09FFFFH
18	32K-WORD	090000H - 097FFFH
17	32K-WORD	088000H - 08FFFFH
16	32K-WORD	080000H - 087FFFH
15	32K-WORD	078000H - 07FFFFH
14	32K-WORD	070000H - 077FFFH
13	32K-WORD	068000H - 06FFFFH
12	32K-WORD	060000H - 067FFFH
11	32K-WORD	058000H - 05FFFFH
10	32K-WORD	050000H - 057FFFH
9	32K-WORD	048000H - 04FFFFH
8	32K-WORD	040000H - 047FFFH
7	32K-WORD	038000H - 03FFFFH
6	32K-WORD	030000H - 037FFFH
5	32K-WORD	028000H - 02FFFFH
4	32K-WORD	020000H - 027FFFH
3	32K-WORD	018000H - 01FFFFH
2	32K-WORD	010000H - 017FFFH
1	32K-WORD	008000H - 00FFFFH
0	32K-WORD	000000H - 007FFFH

Figure 2. Memory Map (Top Parameter)

Table 2. Identifier Codes and OTP Address for Read Operation

	Code	Address [A ₂₁ -A ₀] ⁽¹⁾	Data [DQ ₁₅ -DQ ₀]	Notes
Manufacturer Code	Manufacturer Code	000000H	00B0H	
Device Code	Top Parameter Device Code	000001H	00B0H	1
Block Lock Configuration Code	Block is Unlocked	Block Address + 2	DQ ₀ = 0	2
	Block is Locked		DQ ₀ = 1	2
	Block is not Locked-Down	Block Address + 2	DQ ₁ = 0	2
	Block is Locked-Down		DQ ₁ = 1	2
OTP	OTP Lock	000080H	OTP-LK	3
	OTP	000081-000088H	OTP	4

NOTES:

1. Top parameter device has its parameter blocks at the highest address.
2. DQ₁₅-DQ₂ are reserved for future implementation.
3. OTP-LK=OTP Block Lock configuration.
4. OTP=OTP Block data.

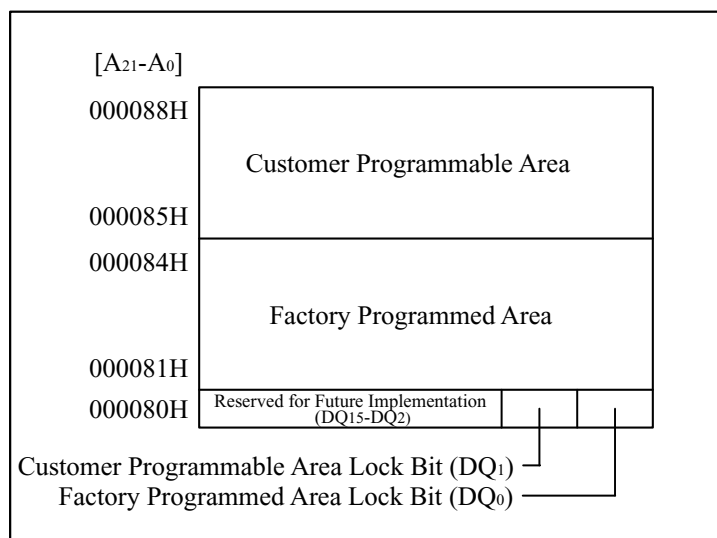

Figure 3. OTP Block Address Map for OTP Program
(The area outside 80H~88H cannot be used.)

Table 3. Bus Operation^(1, 2)

Mode	Notes	RST#	CE#	OE#	WE#	Address	DQ ₀₋₁₅
Read Array	6	V _{IH}	V _{IL}	V _{IL}	V _{IH}	X	D _{OUT}
Output Disable		V _{IH}	V _{IL}	V _{IH}	V _{IH}	X	High Z
Standby		V _{IH}	V _{IH}	X	X	X	High Z
Reset	3	V _{IL}	X	X	X	X	High Z
Read Identifier Codes/OTP	6	V _{IH}	V _{IL}	V _{IL}	V _{IH}	See Table 2	See Table 2
Read Query	6,7	V _{IH}	V _{IL}	V _{IL}	V _{IH}	See Appendix	See Appendix
Write	4,5,6	V _{IH}	V _{IL}	V _{IH}	V _{IL}	X	D _{IN}

NOTES:

1. See DC Characteristics for V_{IL} or V_{IH} voltages.
2. X can be V_{IL} or V_{IH} for control pins and addresses.
3. RST# at GND±0.2V ensures the lowest power consumption.
4. Command writes involving block erase, full chip erase, (page buffer) program or OTP program are reliably executed when V_{CC}=2.7V-3.6V.
5. Refer to Table 4 for valid D_{IN} during a write operation.
6. Never hold OE# low and WE# low at the same timing.
7. Refer to Appendix of LH28F640BF series for more information about query code.

Table 4. Command Definitions⁽¹⁰⁾

Command	Bus Cycles Req'd	Notes	First Bus Cycle			Second Bus Cycle		
			Oper ⁽¹⁾	Addr ⁽²⁾	Data ⁽³⁾	Oper ⁽¹⁾	Addr ⁽²⁾	Data ⁽³⁾
Read Array	1	2	Write	X	FFH			
Read Identifier Codes/OTP	≥ 2	2,3,4	Write	X	90H	Read	IA or OA	ID or OD
Read Query	≥ 2	2,3,4	Write	X	98H	Read	QA	QD
Read Status Register	2	2,3,11	Write	BA or WA	70H	Read	BA or WA	SRD
Clear Status Register	1	2	Write	X	50H			
Block Erase	2	2,3,5	Write	BA	20H	Write	BA	D0H
Full Chip Erase	2	2,5,8	Write	X	30H	Write	X	D0H
Program	2	2,3,5,6	Write	WA	40H or 10H	Write	WA	WD
Page Buffer Program	≥ 4	2,3,5,7	Write	WA	E8H	Write	WA	N-1
Block Erase and (Page Buffer) Program Suspend	1	2,8	Write	BA or WA	B0H			
Block Erase and (Page Buffer) Program Resume	1	2,8	Write	BA or WA	D0H			
Set Block Lock Bit	2	2	Write	BA	60H	Write	BA	01H
Clear Block Lock Bit	2	2,9	Write	BA	60H	Write	BA	D0H
Set Block Lock-down Bit	2	2	Write	BA	60H	Write	BA	2FH
OTP Program	2	2,3,8	Write	OA	C0H	Write	OA	OD

NOTES:

- Bus operations are defined in Table 3.
- The address which is written at the first bus cycle should be the same as the address which is written at the second bus cycle.
X=Any valid address within the device.
IA=Identifier codes address (See Table 2).
QA=Query codes address. Refer to Appendix of LH28F640BF series for details.
BA=Address within the block being erased, set/cleared block lock bit or set block lock-down bit.
WA=Address of memory location for the Program command or the first address for the Page Buffer Program command.
OA=Address of OTP block to be read or programmed (See Figure 3).
- ID=Data read from identifier codes. (See Table 2).
QD=Data read from query database. Refer to Appendix of LH28F640BF series for details.
SRD=Data read from status register. See Table 7 and Table 8 for a description of the status register bits.
WD=Data to be programmed at location WA. Data is latched on the rising edge of WE# or CE# (whichever goes high first).
OD=Data to be programmed at location OA. Data is latched on the rising edge of WE# or CE# (whichever goes high first).
N-1=N is the number of the words to be loaded into a page buffer.
- Following the Read Identifier Codes/OTP command, read operations access manufacturer code, device code, block lock configuration code, and the data within OTP block (See Table 2).
The Read Query command is available for reading CFI (Common Flash Interface) information.
- Block erase, full chip erase or (page buffer) program cannot be executed when the selected block is locked. Unlocked block can be erased or programmed when RST# is V_{IH}.
- Either 40H or 10H are recognized by the CUI (Command User Interface) as the program setup.
- Following the third bus cycle, inputs the program sequential address and write data of "N" times. Finally, input the any valid address within the target block to be programmed and the confirm command (D0H). Refer to Appendix of LH28F640BF series for details.
- Full chip erase and OTP program operations can not be suspended. The OTP Program command can not be accepted

while the block erase operation is being suspended.

9. Following the Clear Block Lock Bit command, the selected block is unlocked regardless of lock-down configuration.
10. Commands other than those shown above are reserved by SHARP for future device implementations and should not be used.
11. When the status register data is read, input the address to which the erase or program operation is executed.

Table 5. Functions of Block Lock⁽⁴⁾ and Block Lock-Down

Current State				Erase/Program Allowed ⁽²⁾
State	DQ ₁ ⁽¹⁾	DQ ₀ ⁽¹⁾	State Name	
[00]	0	0	Unlocked	Yes
[01] ⁽³⁾	0	1	Locked	No
[10]	1	0	Unlocked	Yes
[11]	1	1	Locked	No

NOTES:

- DQ₀=1: a block is locked; DQ₀=0: a block is unlocked.
DQ₁=1: a block is locked-down; DQ₁=0: a block is not locked-down.
- Erase and program are general terms, respectively, to express: block erase, full chip erase and (page buffer) program operations.
- At power-up or device reset, all blocks default to locked state and are not locked-down, that is, [01] regardless of the states before power-off or reset operation.
- OTP (One Time Program) block has the lock function which is different from those described above.

Table 6. Block Locking State Transitions upon Command Write

Current State			Result after Lock Command Written (Next State)		
State	DQ ₁	DQ ₀	Set Lock ⁽¹⁾	Clear Lock ⁽¹⁾	Set Lock-down ⁽¹⁾
[00]	0	0	[01]	No Change ⁽³⁾	[11] ⁽²⁾
[01]	0	1	No Change	[00]	[11]
[10]	1	0	[11]	No Change	[11] ⁽²⁾
[11]	1	1	No Change	[10]	No Change

NOTES:

- "Set Lock" means Set Block Lock Bit command, "Clear Lock" means Clear Block Lock Bit command and "Set Lock-down" means Set Block Lock-Down Bit command.
- When the Set Block Lock-Down Bit command is written to the unlocked block (DQ₀=0), the corresponding block is locked-down and automatically locked at the same time.
- "No Change" means that the state remains unchanged after the command written.

Table 7. Status Register Definition

R	R	R	R	R	R	R	R
15	14	13	12	11	10	9	8
WSMS	BESS	BEFCES	PBPOPS	R	PBPSS	DPS	R
7	6	5	4	3	2	1	0
SR.15 - SR.8 = RESERVED FOR FUTURE ENHANCEMENTS (R)				<p style="text-align: center;">NOTES:</p> <p>Check SR.7 to determine block erase, full chip erase, (page buffer) program or OTP program completion. SR.6 - SR.1 are invalid while SR.7="0".</p> <p>If both SR.5 and SR.4 are "1"s after a block erase, full chip erase, page buffer program, set/clear block lock bit, set block lock-down bit, attempt, an improper command sequence was entered.</p> <p>SR.1 does not provide a continuous indication of block lock bit. The WSM interrogates the block lock bit only after Block Erase, Full Chip Erase, (Page Buffer) Program or OTP Program command sequences. It informs the system, depending on the attempted operation, if the block lock bit is set. Reading the block lock configuration codes after writing the Read Identifier Codes/OTP command indicates block lock bit status.</p> <p>SR.15 - SR.8, SR.3 and SR.0 are reserved for future use and should be masked out when polling the status register.</p>			
SR.7 = WRITE STATE MACHINE STATUS (WSMS) 1 = Ready 0 = Busy							
SR.6 = BLOCK ERASE SUSPEND STATUS (BESS) 1 = Block Erase Suspended 0 = Block Erase in Progress/Completed							
SR.5 = BLOCK ERASE AND FULL CHIP ERASE STATUS (BEFCES) 1 = Error in Block Erase or Full Chip Erase 0 = Successful Block Erase or Full Chip Erase							
SR.4 = (PAGE BUFFER) PROGRAM AND OTP PROGRAM STATUS (PBPOPS) 1 = Error in (Page Buffer) Program or OTP Program 0 = Successful (Page Buffer) Program or OTP Program							
SR.3 = RESERVED FOR FUTURE ENHANCEMENTS (R)							
SR.2 = (PAGE BUFFER) PROGRAM SUSPEND STATUS (PBPSS) 1 = (Page Buffer) Program Suspended 0 = (Page Buffer) Program in Progress/Completed							
SR.1 = DEVICE PROTECT STATUS (DPS) 1 = Erase or Program Attempted on a Locked Block, Operation Abort 0 = Unlocked							
SR.0 = RESERVED FOR FUTURE ENHANCEMENTS (R)							

Table 8. Extended Status Register Definition

R	R	R	R	R	R	R	R
15	14	13	12	11	10	9	8
SMS	R	R	R	R	R	R	R
7	6	5	4	3	2	1	0

<p>XSR.15-8 = RESERVED FOR FUTURE ENHANCEMENTS (R)</p> <p>XSR.7 = STATE MACHINE STATUS (SMS) 1 = Page Buffer Program available 0 = Page Buffer Program not available</p> <p>XSR.6-0 = RESERVED FOR FUTURE ENHANCEMENTS (R)</p>	<p style="text-align: center;">NOTES:</p> <p>After issue a Page Buffer Program command (E8H), XSR.7="1" indicates that the entered command is accepted. If XSR.7 is "0", the command is not accepted and a next Page Buffer Program command (E8H) should be issued again to check if page buffer is available or not.</p> <p>XSR.15-8 and XSR.6-0 are reserved for future use and should be masked out when polling the extended status register.</p>
--	---

1 Electrical Specifications

1.1 Absolute Maximum Ratings *

Operating Temperature

During Read, Erase and Program 0°C to +70°C ⁽¹⁾

Storage Temperature

During under Bias..... -10°C to +80°C

During non Bias..... -65°C to +125°C

Voltage On Any Pin

(except V_{CC})..... -0.5V to V_{CC}+0.5V ⁽²⁾

V_{CC} Supply Voltage -0.2V to +3.9V ⁽²⁾

Output Short Circuit Current..... 100mA ⁽³⁾

***WARNING:** Stressing the device beyond the "Absolute Maximum Ratings" may cause permanent damage. These are stress ratings only. Operation beyond the "Operating Conditions" is not recommended and extended exposure beyond the "Operating Conditions" may affect device reliability.

NOTES:

1. Operating temperature is for commercial temperature product defined by this specification.
2. All specified voltages are with respect to GND. Minimum DC voltage is -0.5V on input/output pins and -0.2V on V_{CC} pins. During transitions, this level may undershoot to -2.0V for periods <20ns. Maximum DC voltage on input/output pins and V_{CC} is V_{CC}+0.5V which, during transitions, may overshoot to V_{CC}+2.0V for periods <20ns.
3. Output shorted for no more than one second. No more than one output shorted at a time.

1.2 Operating Conditions

Parameter	Symbol	Min.	Typ.	Max.	Unit	Notes
Operating Temperature	T _A	0	+25	+70	°C	
V _{CC} Supply Voltage	V _{CC}	2.7	3.0	3.6	V	1
Main Block Erase Cycling		100,000			Cycles	
Parameter Block Erase Cycling		100,000			Cycles	

NOTES:

1. See DC Characteristics tables for voltage range-specific specification.

1.2.1 Capacitance⁽¹⁾ ($T_A=+25^\circ\text{C}$, $f=1\text{MHz}$)

Parameter	Symbol	Condition	Min.	Typ.	Max.	Unit
Input Capacitance	C_{IN}	$V_{IN}=0.0\text{V}$		6	8	pF
RST# Input Capacitance	C_{IN}	$V_{IN}=0.0\text{V}$		24	30	pF
Output Capacitance	C_{OUT}	$V_{OUT}=0.0\text{V}$		10	12	pF

NOTE:

1. Sampled, not 100% tested.

1.2.2 AC Input/Output Test Conditions

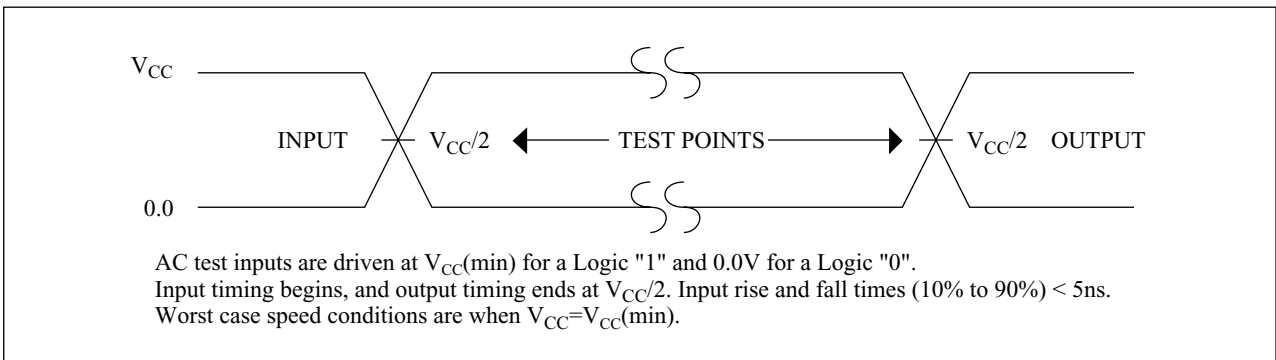

Figure 4. Transient Input/Output Reference Waveform for $V_{CC}=2.7\text{V}-3.6\text{V}$

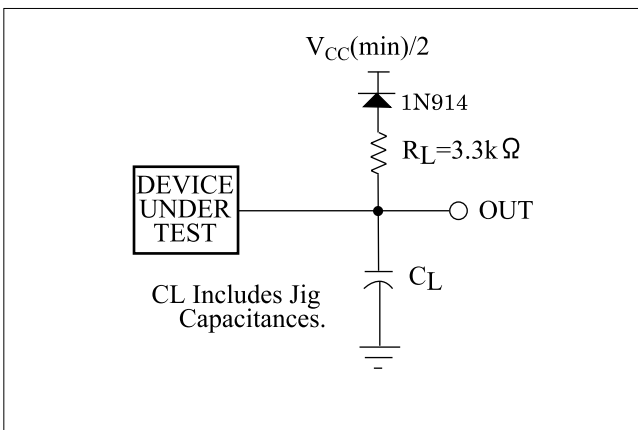

Figure 5. Transient Equivalent Testing Load Circuit

Table 9. Configuration Capacitance Loading Value

Test Configuration	C_L (pF)
$V_{CC}=2.7\text{V}-3.6\text{V}$	50

1.2.3 DC Characteristics

$$V_{CC}=2.7V-3.6V$$

Symbol	Parameter	Notes	Min.	Typ.	Max.	Unit	Test Conditions
I_{LI}	Input Load Current	1	-1.0		+1.0	μA	$V_{CC}=V_{CCMax.}$, $V_{IN}/V_{OUT}=V_{CC}$ or GND
I_{LO}	Output Leakage Current	1	-1.0		+1.0	μA	$V_{CC}=V_{CCMax.}$, $CE\#=RST\#$, $V_{CC}\pm 0.2V$
I_{CCS}	V_{CC} Standby Current	1		6	25	μA	$V_{CC}=V_{CCMax.}$, $CE\#=RST\#$, $V_{CC}\pm 0.2V$
I_{CCAS}	V_{CC} Automatic Power Savings Current	1,4		4	20	μA	$V_{CC}=V_{CCMax.}$, $CE\#=GND\pm 0.2V$
I_{CCD}	V_{CC} Reset Power-Down Current	1		4	20	μA	$RST\#=GND\pm 0.2V$
I_{CCR}	Average V_{CC} Read Current Normal Mode	1		15	25	mA	$V_{CC}=V_{CCMax.}$, $CE\#=V_{IL}$, $OE\#=V_{IH}$, $f=5MHz$
	Average V_{CC} Read Current Page Mode	8 Word Read	1	5	10	mA	
I_{CCW}	V_{CC} (Page Buffer) Program Current	1,5		20	60	mA	
I_{CCE}	V_{CC} Block Erase, Full Chip Erase Current	1,5		10	30	mA	
I_{CCWS} I_{CCES}	V_{CC} (Page Buffer) Program or Block Erase Suspend Current	1,2		15	210	μA	$CE\#=V_{IH}$
V_{IL}	Input Low Voltage	5	-0.4		0.4	V	
V_{IH}	Input High Voltage	5	V_{CC} -0.4		V_{CC} + 0.4	V	
V_{OL}	Output Low Voltage	5			0.2	V	$V_{CC}=V_{CCMin.}$, $I_{OL}=100\mu A$
V_{OH}	Output High Voltage	5	V_{CC} -0.2			V	$V_{CC}=V_{CCMin.}$, $I_{OH}=-100\mu A$
V_{LKO}	V_{CC} Lockout Voltage	3	1.5			V	

NOTES:

- All currents are in RMS unless otherwise noted. Typical values are the reference values at $V_{CC}=3.0V$ and $T_A=+25^\circ C$ unless V_{CC} is specified.
- I_{CCWS} and I_{CCES} are specified with the device de-selected. If read or (page buffer) program while in block erase suspend mode, the device's current draw is the sum of I_{CCWS} or I_{CCES} and I_{CCR} or I_{CCW} , respectively.
- Block erase, full chip erase, (page buffer) program and OTP program are inhibited when $V_{CC}\leq V_{LKO}$, and not guaranteed outside the specified voltage.
- The Automatic Power Savings (APS) feature automatically places the device in power save mode after read cycle completion. Standard address access timings (t_{AVQV}) provide new data when addresses are changed.
- Sampled, not 100% tested.

1.2.4 AC Characteristics - Read-Only Operations⁽¹⁾
 $V_{CC}=2.7V-3.6V, T_A=0^{\circ}C \text{ to } +70^{\circ}C$

Symbol	Parameter	Notes	Min.	Max.	Unit
t_{AVAV}	Read Cycle Time		90		ns
t_{AVQV}	Address to Output Delay			90	ns
t_{ELQV}	CE# to Output Delay	3		90	ns
t_{APA}	Page Address Access Time			35	ns
t_{GLQV}	OE# to Output Delay	3		20	ns
t_{PHQV}	RST# High to Output Delay			150	ns
t_{EHQZ}, t_{GHQZ}	CE# or OE# to Output in High Z, Whichever Occurs First	2		20	ns
t_{ELQX}	CE# to Output in Low Z	2	0		ns
t_{GLQX}	OE# to Output in Low Z	2	0		ns
t_{OH}	Output Hold from First Occurring Address, CE# or OE# change	2	0		ns

NOTES:

1. See AC input/output reference waveform for timing measurements and maximum allowable input slew rate.
2. Sampled, not 100% tested.
3. OE# may be delayed up to $t_{ELQV} - t_{GLQV}$ after the falling edge of CE# without impact to t_{ELQV} .

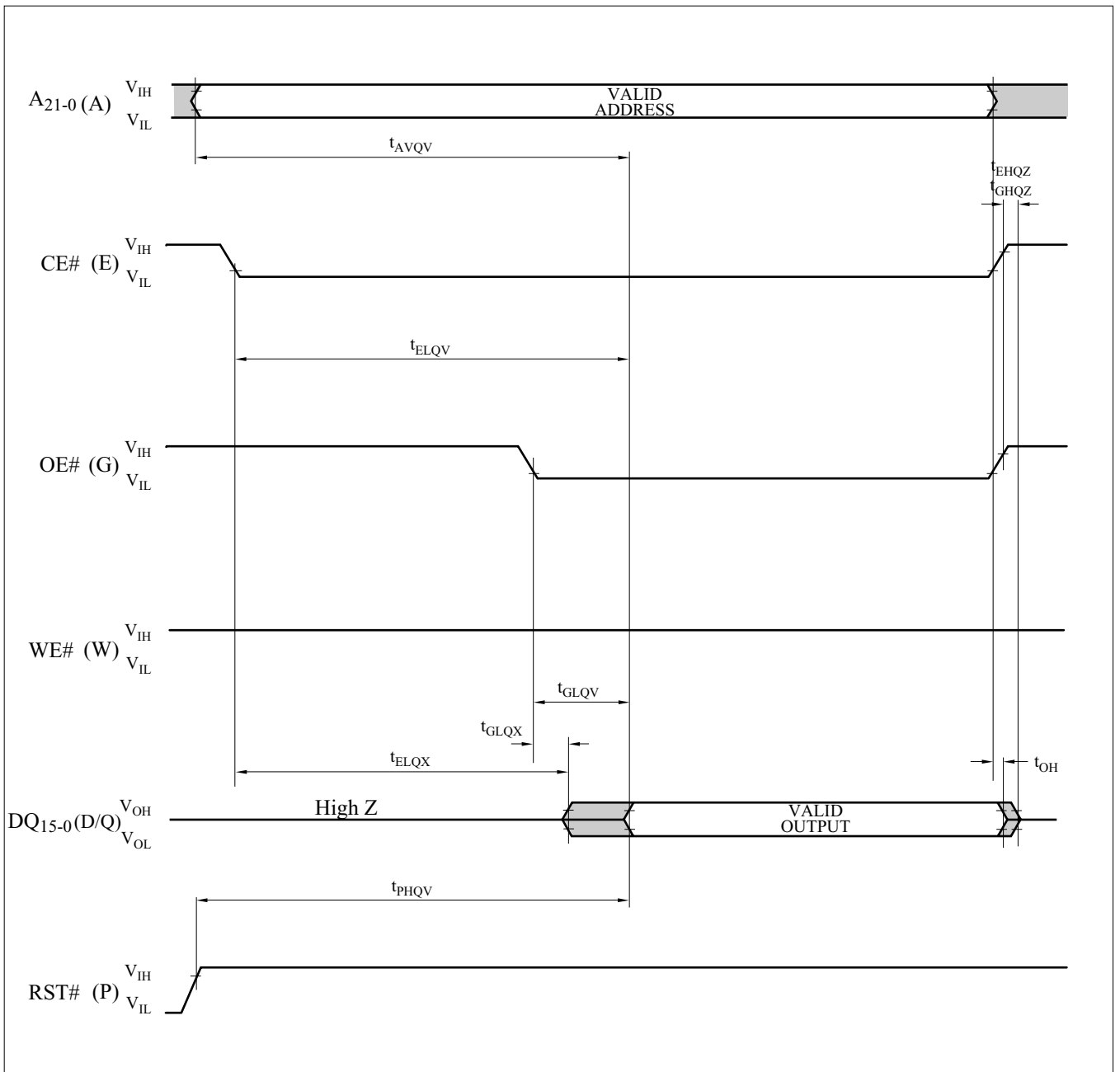

Figure 6. AC Waveform for Single Asynchronous Read Operations from Status Register, Identifier Codes, OTP Block or Query Code

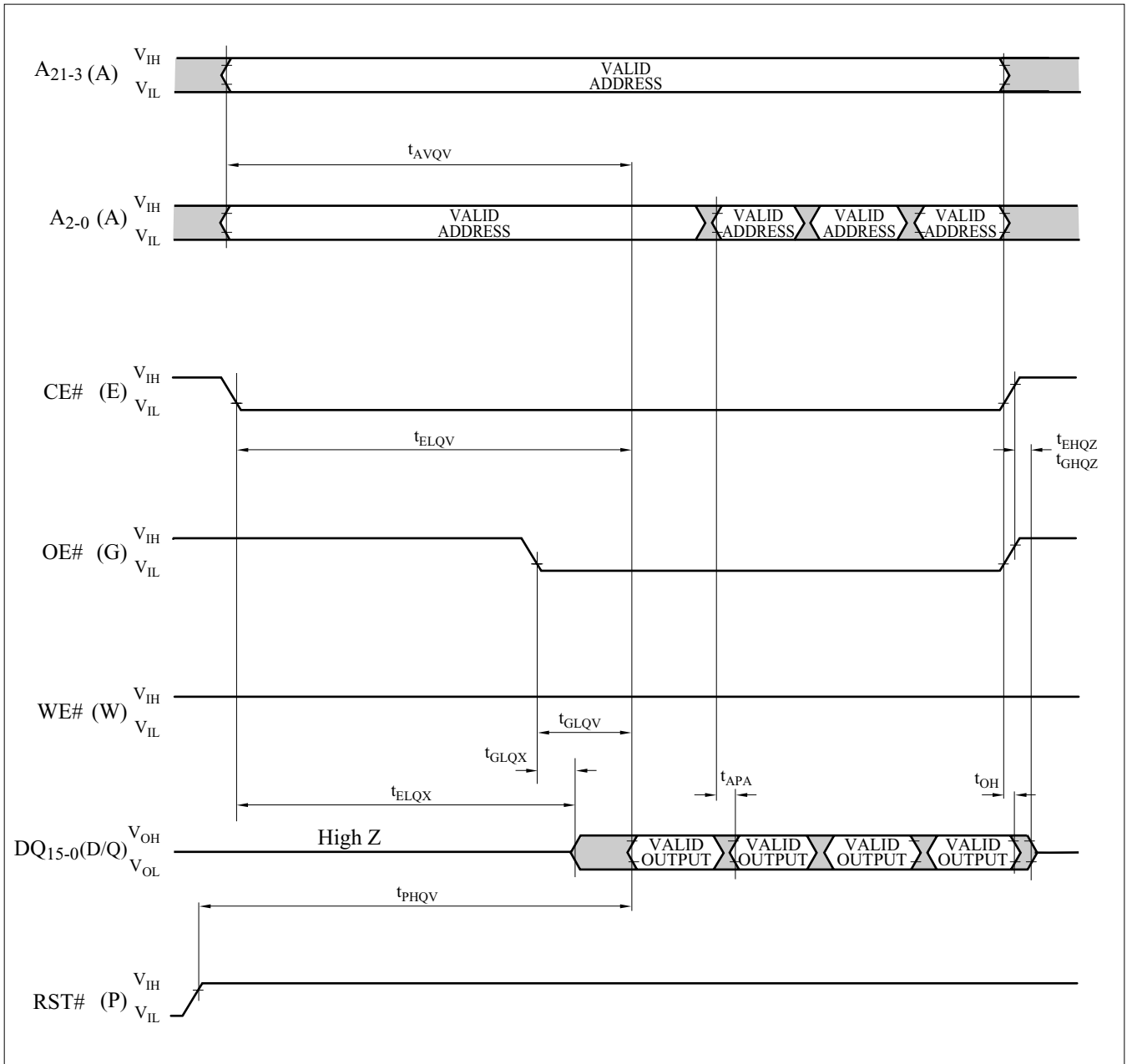

Figure 7. AC Waveform for Asynchronous Page Mode Read Operations from Main Blocks or Parameter Blocks

1.2.5 AC Characteristics - Write Operations^{(1), (2)}

$$V_{CC}=2.7V-3.6V, T_A=0^{\circ}C \text{ to } +70^{\circ}C$$

Symbol	Parameter	Notes	Min.	Max.	Unit
t_{AVAV}	Write Cycle Time		90		ns
t_{PHWL} (t_{PHEL})	RST# High Recovery to WE# (CE#) Going Low	3	150		ns
t_{ELWL} (t_{WLEL})	CE# (WE#) Setup to WE# (CE#) Going Low	4	0		ns
t_{WLWH} (t_{ELEH})	WE# (CE#) Pulse Width	4	60		ns
t_{DVWH} (t_{DVEH})	Data Setup to WE# (CE#) Going High	7	40		ns
t_{AVWH} (t_{AVEH})	Address Setup to WE# (CE#) Going High	7	50		ns
t_{WHEH} (t_{EHWL})	CE# (WE#) Hold from WE# (CE#) High		0		ns
t_{WHDX} (t_{EHDX})	Data Hold from WE# (CE#) High		0		ns
t_{WHAX} (t_{EHAX})	Address Hold from WE# (CE#) High		0		ns
t_{WHWL} (t_{EHEL})	WE# (CE#) Pulse Width High	5	30		ns
t_{WHGL} (t_{EHGL})	Write Recovery before Read		30		ns
t_{WHR0} (t_{EHR0})	WE# (CE#) High to SR.7 Going "0"	3, 6		t_{AVQV}^+ 50	ns

NOTES:

- The timing characteristics for reading the status register during block erase, full chip erase, (page buffer) program and OTP program operations are the same as during read-only operations. Refer to AC Characteristics for read-only operations.
- A write operation can be initiated and terminated with either CE# or WE#.
- Sampled, not 100% tested.
- Write pulse width (t_{WP}) is defined from the falling edge of CE# or WE# (whichever goes low last) to the rising edge of CE# or WE# (whichever goes high first). Hence, $t_{WP}=t_{WLWH}=t_{ELEH}=t_{WLEH}=t_{ELWH}$.
- Write pulse width high (t_{WPH}) is defined from the rising edge of CE# or WE# (whichever goes high first) to the falling edge of CE# or WE# (whichever goes low last). Hence, $t_{WPH}=t_{WHWL}=t_{EHEL}=t_{WHEL}=t_{EHWL}$.
- t_{WHR0} (t_{EHR0}) after the Read Query or Read Identifier Codes/OTP command= t_{AVQV}^+ +100ns.
- Refer to Table 4 for valid address and data for block erase, full chip erase, (page buffer) program, OTP program or lock bit configuration.

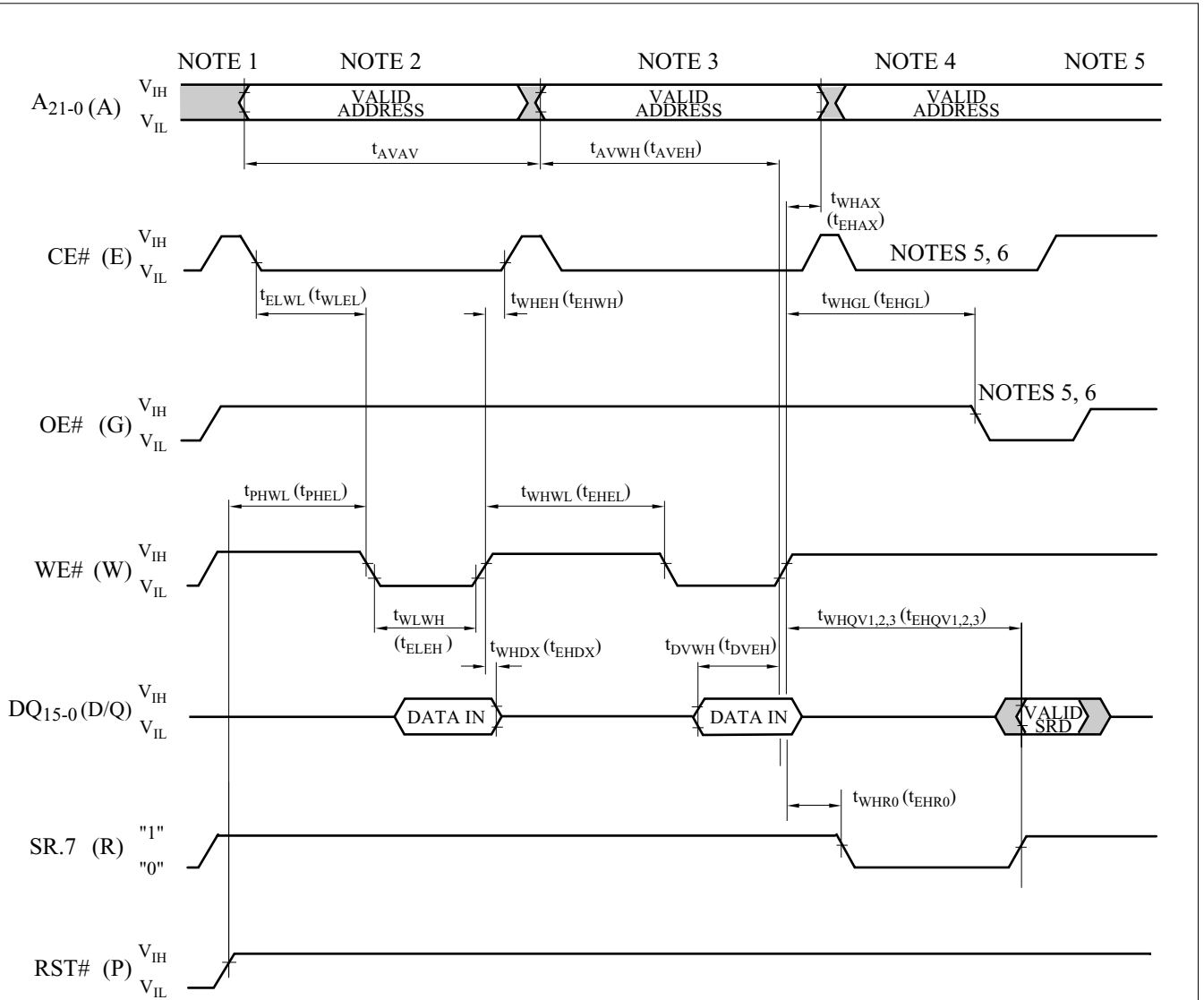

NOTES:

1. V_{CC} power-up and standby.
2. Write each first cycle command.
3. Write each second cycle command or valid address and data.
4. Automated erase or program delay.
5. Read status register data.
6. For read operation, OE# and CE# must be driven active, and WE# de-asserted.

Figure 8. AC Waveform for Write Operations

1.2.6 Reset Operations

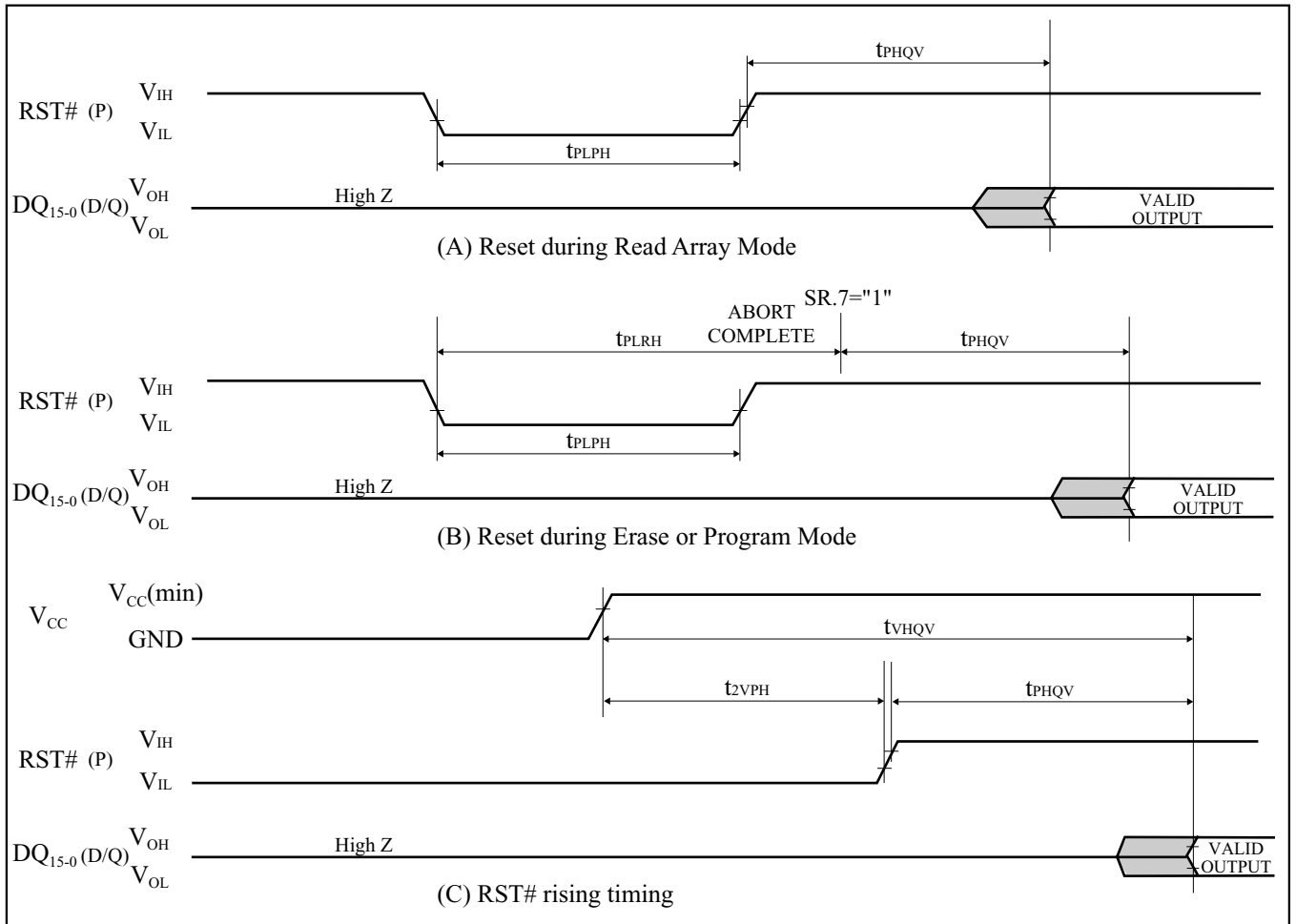

Figure 9. AC Waveform for Reset Operations

Reset AC Specifications ($V_{CC}=2.7V-3.6V$, $T_A=0^{\circ}C$ to $+70^{\circ}C$)

Symbol	Parameter	Notes	Min.	Max.	Unit
t_{PLPH}	RST# Low to Reset during Read (RST# should be low during power-up.)	1, 2, 3	100		ns
t_{PLRH}	RST# Low to Reset during Erase or Program	1, 3, 4		22	μs
t_{2VPH}	V_{CC} 2.7V to RST# High	1, 3, 5	100		ns
t_{VHQP}	V_{CC} 2.7V to Output Delay	3		1	ms

NOTES:

1. A reset time, t_{PHQV} , is required from the later of SR.7 going "1" or RST# going high until outputs are valid. Refer to AC Characteristics - Read-Only Operations for t_{PHQV} .
2. t_{PLPH} is $<100ns$ the device may still reset but this is not guaranteed.
3. Sampled, not 100% tested.
4. If RST# asserted while a block erase, full chip erase, (page buffer) program or OTP program operation is not executing, the reset will complete within 100ns.
5. When the device power-up, holding RST# low minimum 100ns is required after V_{CC} has been in predefined range and also has been in stable there.

1.2.7 Block Erase, Full Chip Erase, (Page Buffer) Program and OTP Program Performance⁽³⁾ $V_{CC}=2.7V-3.6V$, $T_A=0^{\circ}C$ to $+70^{\circ}C$

Symbol	Parameter	Notes	Page Buffer Command is Used or not Used	Min.	Typ. ⁽¹⁾	Max. ⁽²⁾	Unit
t_{WPB}	4K-Word Parameter Block Program Time	2	Not Used		0.05	0.3	s
		2	Used		0.03	0.12	s
t_{WMB}	32K-Word Main Block Program Time	2	Not Used		0.38	2.4	s
		2	Used		0.24	1.0	s
$t_{WHQV1}/$ t_{EHQV1}	Word Program Time	2	Not Used		11	200	μs
		2	Used		7	100	μs
$t_{WHOV1}/$ t_{EHOV1}	OTP Program Time	2	Not Used		36	400	μs
$t_{WHQV2}/$ t_{EHQV2}	4K-Word Parameter Block Erase Time	2	-		0.3	4	s
$t_{WHQV3}/$ t_{EHQV3}	32K-Word Main Block Erase Time	2	-		0.6	5	s
	Full Chip Erase Time	2			80	700	s
$t_{WHRH1}/$ t_{EHRH1}	(Page Buffer) Program Suspend Latency Time to Read	4	-		5	10	μs
$t_{WHRH2}/$ t_{EHRH2}	Block Erase Suspend Latency Time to Read	4	-		5	20	μs
t_{ERES}	Latency Time from Block Erase Resume Command to Block Erase Suspend Command	5	-	500			μs

NOTES:

1. Typical values measured at $V_{CC}=3.0V$ and $T_A=+25^{\circ}C$. Assumes corresponding lock bits are not set. Subject to change based on device characterization.
2. Excludes external system-level overhead.
3. Sampled, but not 100% tested.
4. A latency time is required from writing suspend command (WE# or CE# going high) until SR.7 going "1".
5. If the interval time from a Block Erase Resume command to a subsequent Block Erase Suspend command is shorter than t_{ERES} and its sequence is repeated, the block erase operation may not be finished.

2 Related Document Information⁽¹⁾

Document No.	Document Name
FUM00701	LH28F640BF series Appendix

NOTE:

1. International customers should contact their local SHARP or distribution sales offices.

A-1 RECOMMENDED OPERATING CONDITIONS

A-1.1 At Device Power-Up

AC timing illustrated in Figure A-1 is recommended for the supply voltages and the control signals at device power-up. If the timing in the figure is ignored, the device may not operate correctly.

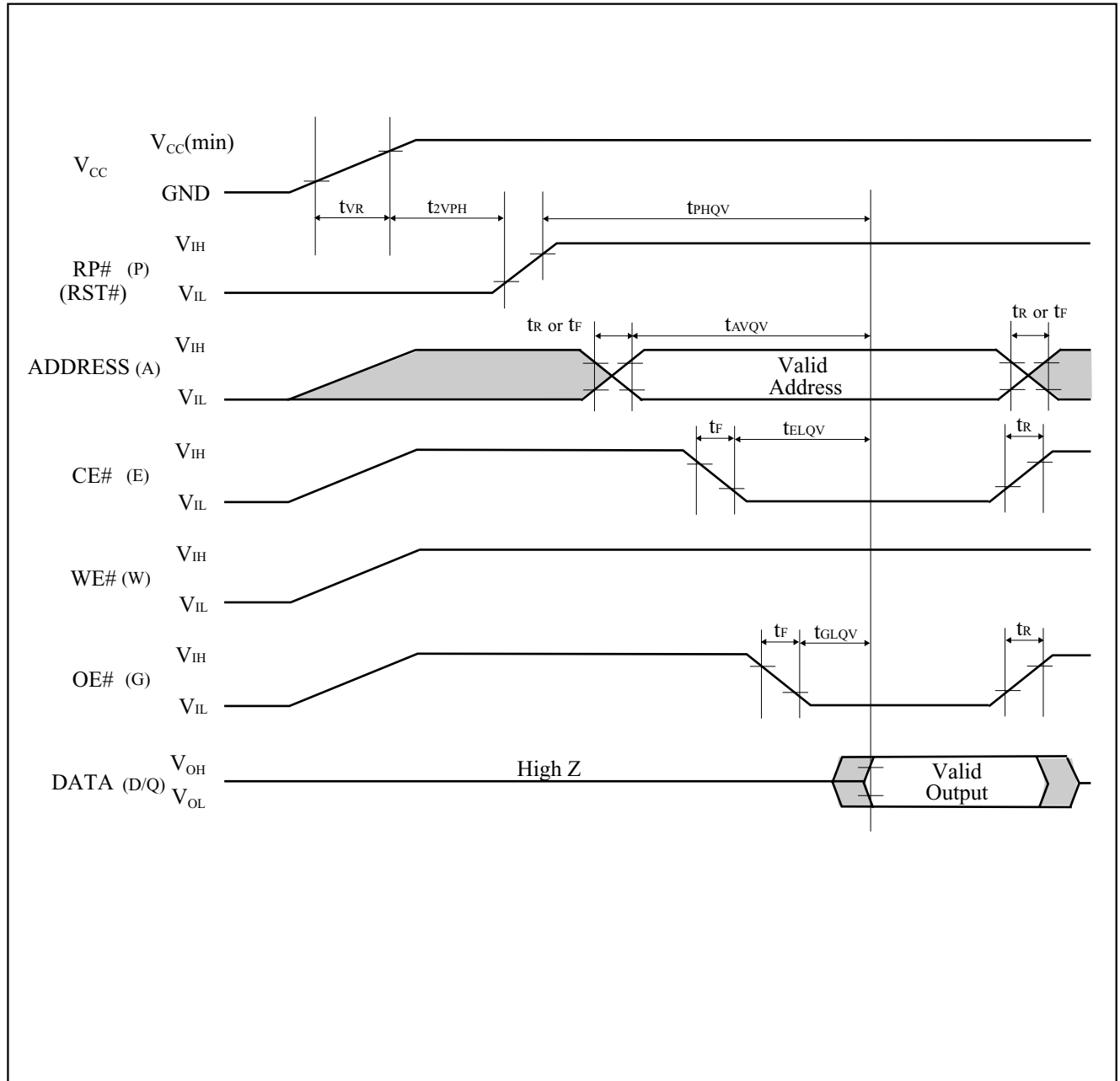

Figure A-1. AC Timing at Device Power-Up

For the AC specifications t_{VR} , t_r , t_f in the figure, refer to the next page. See the "ELECTRICAL SPECIFICATIONS" described in specifications for the supply voltage range, the operating temperature and the AC specifications not shown in the next page.

A-1.1.1 Rise and Fall Time

Symbol	Parameter	Notes	Min.	Max.	Unit
t_{VR}	V_{CC} Rise Time	1	0.5	30000	$\mu\text{s}/\text{V}$
t_R	Input Signal Rise Time	1, 2		1	$\mu\text{s}/\text{V}$
t_F	Input Signal Fall Time	1, 2		1	$\mu\text{s}/\text{V}$

NOTES:

1. Sampled, not 100% tested.
2. This specification is applied for not only the device power-up but also the normal operations.

A-1.2 Glitch Noises

Do not input the glitch noises which are below V_{IH} (Min.) or above V_{IL} (Max.) on address, data, reset, and control signals, as shown in Figure A-2 (b). The acceptable glitch noises are illustrated in Figure A-2 (a).

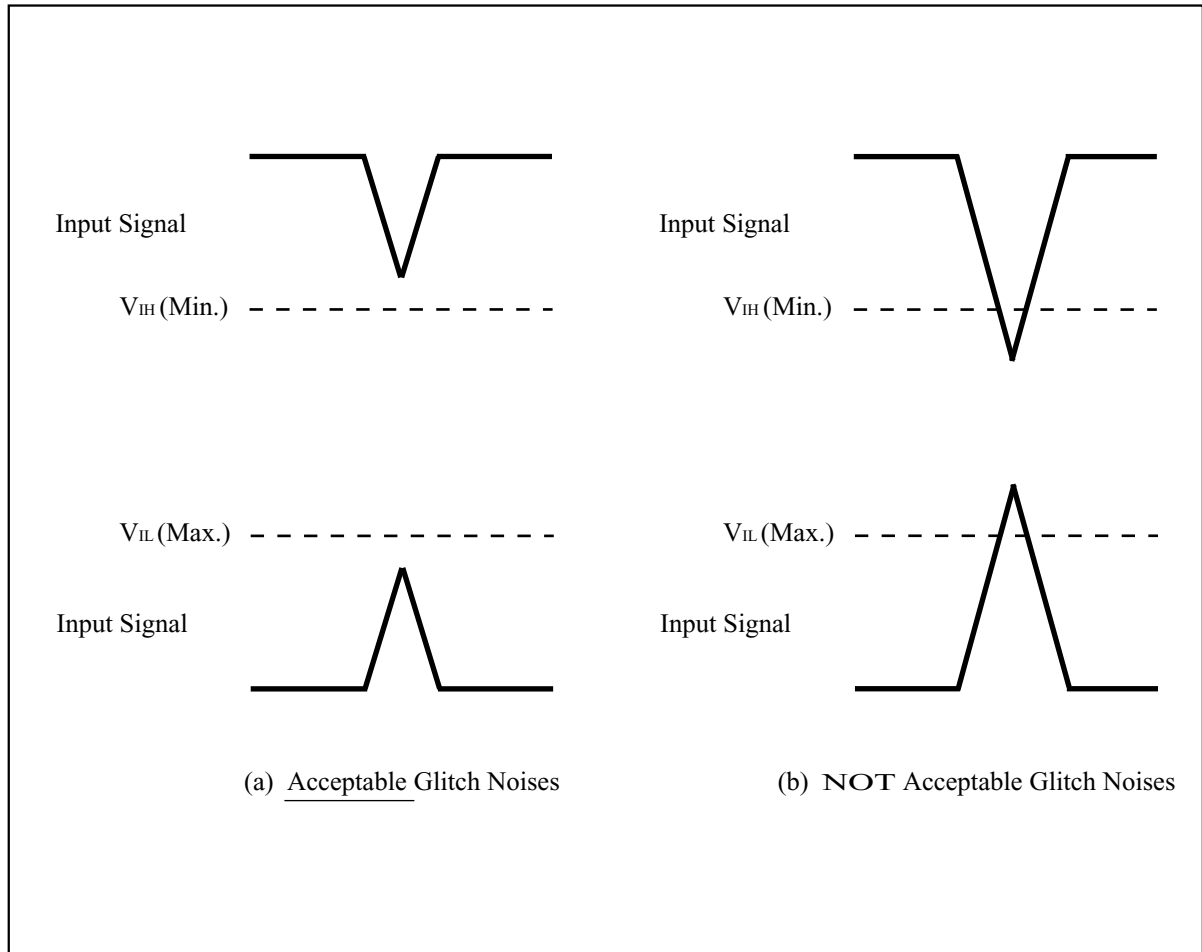

Figure A-2. Waveform for Glitch Noises

See the “DC CHARACTERISTICS” described in specifications for V_{IH} (Min.) and V_{IL} (Max.).

A-2 RELATED DOCUMENT INFORMATION⁽¹⁾

Document No.	Document Name
AP-001-SD-E	Flash Memory Family Software Drivers
AP-006-PT-E	Data Protection Method of SHARP Flash Memory
AP-007-SW-E	RP#, V_{PP} Electric Potential Switching Circuit

NOTE:

1. International customers should contact their local SHARP or distribution sales office.