



No. ※3982

**LC89582**

**ATIP Decoder  
for CD-WO and CD-MO Recorders**

**Preliminary**

**Overview**

The LC89582 is an Absolute Time In Pre-groove (ATIP) decoder IC for use with CD-WO and CD-MO discs complying with the Orange Book specifications. It decodes ATIP data from the disc wobble signal, performs data interpolation and parity checking and then outputs the data to the host CPU. In addition, it controls the spindle motor drive, using the wobble signal as the control input.

The LC89582 comprises an ATIP decoder circuit, a C<sup>2</sup>B serial interface, a timing generator, a constant linear velocity (CLV) servocontroller, two analog switches and an adjustment-free digital PLL. Optionally, the LC89582 can use an external, analog PLL if different PLL characteristics are required.

The LC89582 operates from a 5 V supply and is available in 48-pin QIPs.

**Features**

- ATIP data decoded from wobble signal
- ATIP sync detector output
- Data interpolator
- Parity detector
- C<sup>2</sup>B serial interface to host CPU
- Constant linear velocity servocontroller
- Adjustment-free digital PLL
- Low-power CMOS process
- 5 V supply
- 48-pin QIP

**Pin Assignment**

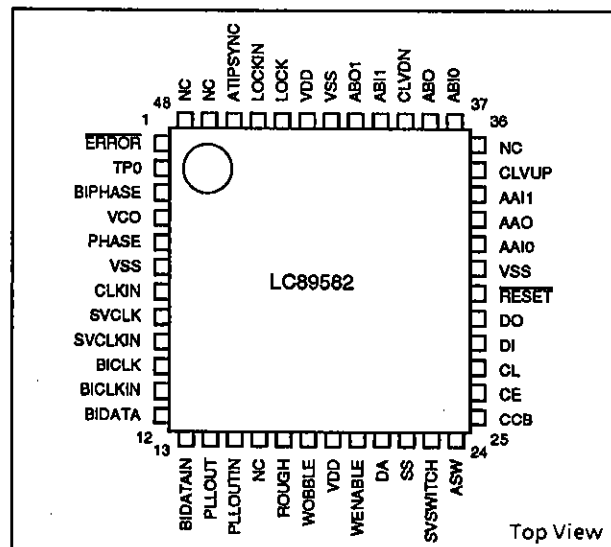

**Package Dimensions**

unit: mm

**3156-QIP48E**

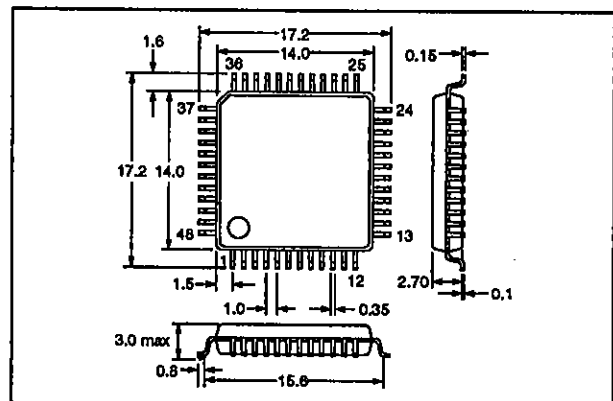

Block Diagram

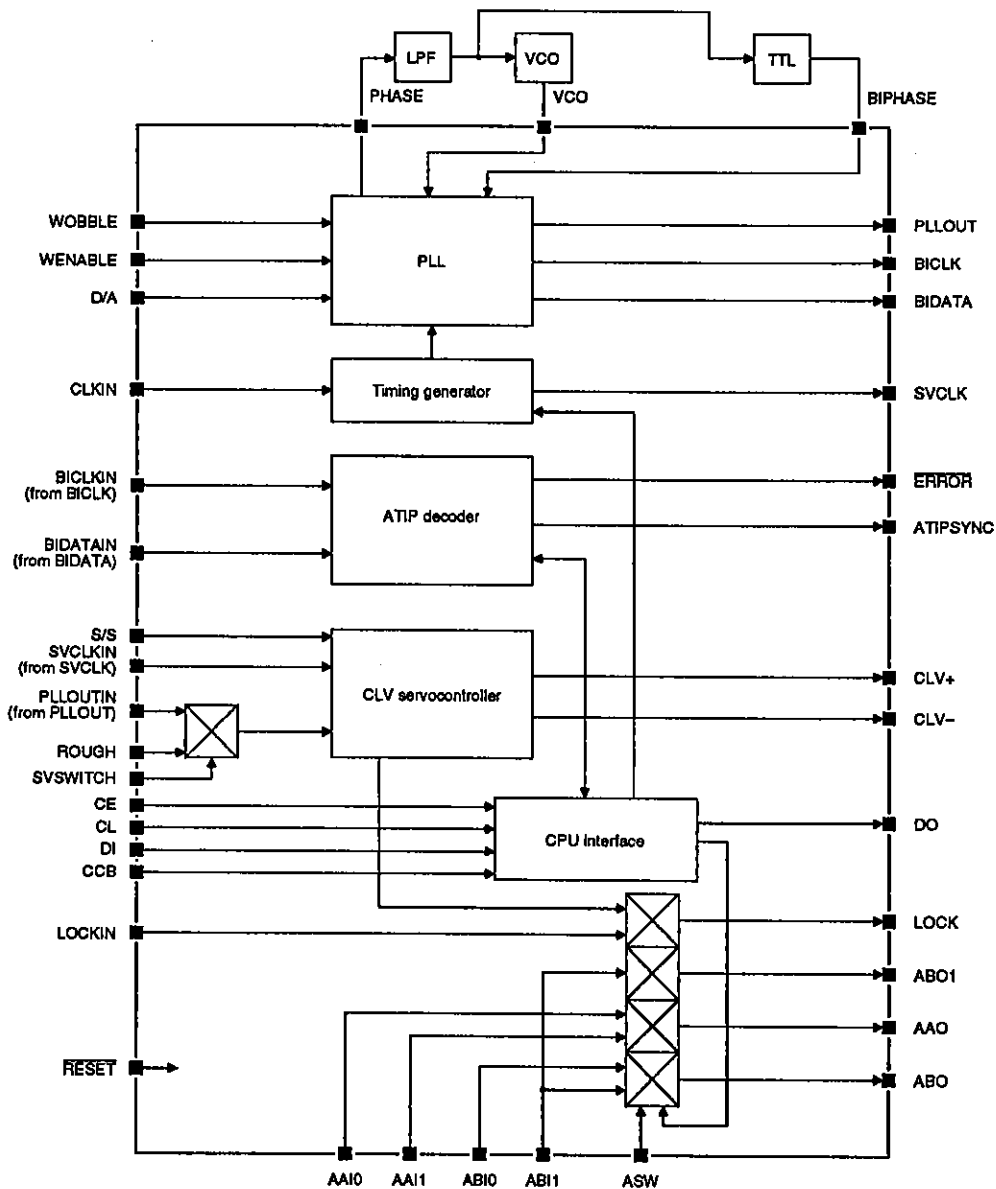

Pin Functions

Number	Name	Function
1	ERROR	Bi-phase data parity error indication output
2	TPO	Test input. Normally connected to VDD
3	BIPHASE	Bi-phase signal input
4	VCO	352.8 kHz VCO output clock input
5	PHASE	PLL phase comparator output
6	VSS	Ground
7	CLKIN	16.9344 MHz clock input
8	SVCLK	2.8224 or 5.6448 MHz CLV servocontroller clock output
9	SVCLKIN	CLV servocontroller reference clock input. Normally connected to SVCLK

LC89582

Number	Name	Function
10	BICKL	6.3 or 12.6 kHz bi-phase data clock output
11	BICKIN	Bi-phase clock input for ATIP decoder. Normally connected to BICKL
12	BIDATA	Bi-phase data output
13	BIDATAIN	Bi-phase data input for ATIP decoder. Normally connected to BIDATA
14	PLLOUT	22.05 or 44.1 kHz carrier frequency clock output
15	PLLOUTIN	CLV servocontroller wobble-signal clock input. Normally connected to PLLOUT
16	NC	No connection
17	ROUGH	CLV servocontroller rough-servo mode clock input
18	WOBBLE	Tracking error wobble-component signal input
19	VDD	5 V supply
20	WENABLE	WOBBLE input enable control input
21	D/A	Internal, digital or external, analog PLL select input
22	S/S	CLV+ and CLV- output function select input
23	SVSWITCH	PLLOUTIN or ROUGH clock source select input
24	ASW	Analog switches control input
25	CCB	CPU interface type select input
26	CE	Chip enable input
27	CL	Data clock input
28	DI	Data input
29	DO	Data output
30	RESET	Active-LOW reset input
31	VSS	Ground
32	AAI0	Analog switch A input 0
33	AAO	Analog switch A output
34	AAI1	Analog switch A input 1
35	CLV+	CLV servocontroller control output
36	NC	No connection
37	ABIO	Analog switch B input 0
38	ABO	Analog switch B output
39	CLV-	CLV servocontroller control output
40	ABI1	Analog switch B input 1
41	ABO1	Analog switch B output 1
42	VSS	Ground
43	VDD	5 V supply
44	LOCK	CLV servocontroller lock indication output
45	LOCKIN	CD-decoder lock signal input
46	ATIPSYNC	ATIP sync detector output
47, 48	NC	No connection

## Specifications

### Absolute Maximum Ratings

Parameter	Symbol	Ratings	Unit
Supply voltage range	$V_{DD}$	-0.3 to 7.0	V
Input voltage range (See note 1.)	$V_I$	-0.3 to $V_{DD} + 0.3$	V
Output voltage range (See note 1.)	$V_O$	-0.3 to $V_{DD} + 0.3$	V
Operating temperature range	$T_{opr}$	-30 to 70	°C
Storage temperature range	$T_{stg}$	-55 to 125	°C
Soldering temperature (See note 2.)	$T_{sld}$	260	°C

#### Notes

- $T_a = 25\text{ °C}$
- $t < 10\text{ s}$

### Recommended Operating Conditions

$T_a = 25\text{ °C}$

Parameter	Symbol	Ratings	Unit
Supply voltage range	$V_{DD}$	4.5 to 5.5	V

### DC Electrical Characteristics

$V_{DD} = 4.5\text{ to }5.5\text{ V}$ ,  $V_{SS} = 0\text{ V}$ ,  $T_a = -30\text{ to }70\text{ °C}$

Parameter	Symbol	Conditions	Rating			Unit
			min	typ	max	
LOW-level input voltage	$V_{IL}$		-	-	0.8	V
HIGH-level input voltage	$V_{IH}$		2.2	-	-	V
Input voltage	$V_I$		0	-	$V_{DD}$	V
LOW-level output voltage	$V_{OL}$	$I_{OL} = 3\text{ mA}$	-	-	0.4	V
HIGH-level output voltage	$V_{OH}$	$I_{OH} = 3\text{ mA}$	2.4	-	-	V

### AC Electrical Characteristics

#### Reset circuit

$V_{DD} = 4.5\text{ to }5.5\text{ V}$ ,  $V_{SS} = 0\text{ V}$ ,  $T_a = -30\text{ to }70\text{ °C}$ ,  $V_{OL} = 0.8\text{ V}$ ,  $V_{OH} = 2.2\text{ V}$

Parameter	Symbol	Conditions	Ratings			Unit
			min	typ	max	
RESET LOW-level pulsewidth	$t_{RL}$		100	-	-	ns

#### Reset circuit waveform

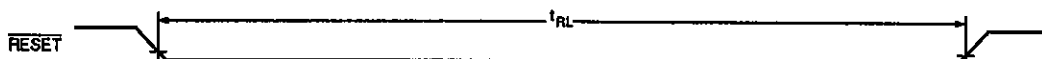

## LC89582

### CPU Interface

$V_{DD} = 4.5$  to  $5.5$  V,  $V_{SS} = 0$  V,  $T_a = -30$  to  $70$  °C,  $V_{IL} = V_{OL} = 0.8$  V,  $V_{IH} = V_{OH} = 2.2$  V

Parameter	Symbol	Conditions	Ratings			Unit
			min	typ	max	
CL HIGH-level pulsewidth	$t_{CLH}$		100	–	–	ns
CL LOW-level pulsewidth	$t_{CLL}$		100	–	–	ns
CE to CL setup time	$t_{CES}$		10	–	–	ns
CE to CL hold time	$t_{CEH}$		10	–	–	ns
DI to CL setup time	$t_{DIS}$		5	–	–	ns
DI to CL hold time	$t_{DIH}$		15	–	–	ns
CL to DO output delay time	$t_{DOD}$		–	–	70	ns

### CPU Interface waveforms

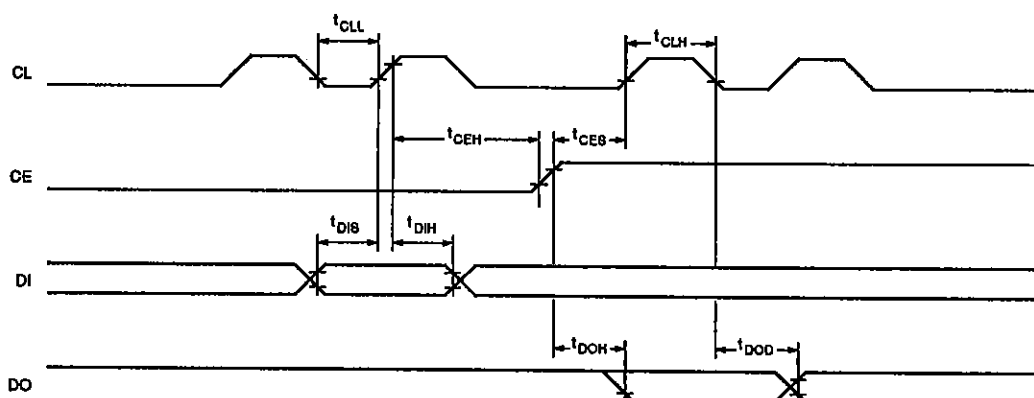

### Timing generator

$V_{DD} = 4.5$  to  $5.5$  V,  $V_{SS} = 0$  V,  $T_a = -30$  to  $70$  °C,  $V_{IL} = V_{OL} = 0.8$  V,  $V_{IH} = V_{OH} = 2.2$  V

Parameter	Symbol	Conditions	Ratings			Unit
			min	typ	max	
CLKIN input frequency	$f_{CLKIN}$		–	16.9344	20	MHz
CLKIN HIGH-level pulsewidth	$t_{CLKH}$		25	–	–	ns
CLKIN LOW-level pulsewidth	$t_{CLKL}$		25	–	–	ns
CLKIN to SVCLK output delay time	$t_{CLKSV}$		–	–	50	ns
SVCLK output frequency	$f_{SVCLK}$	Normal-speed mode	–	$\frac{1}{2}f_{CLKIN}$	–	MHz
		Double-speed mode	–	$\frac{1}{2}f_{CLKIN}$	–	

Timing generator waveforms

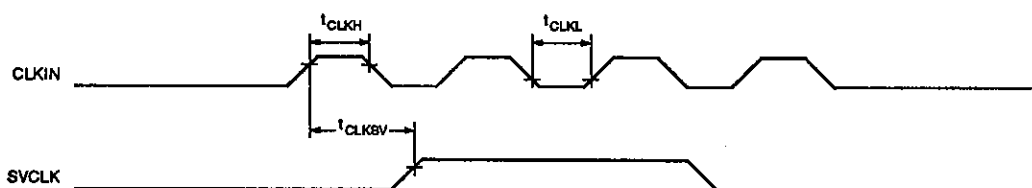

Analog PLL

$V_{DD} = 4.5$  to  $5.5$  V,  $V_{SS} = 0$  V,  $T_a = -30$  to  $70$  °C,  $V_{IL} = V_{OL} = 0.8$  V,  $V_{IH} = V_{OH} = 2.2$  V

Parameter	Symbol	Conditions	Ratings			Unit
			min	typ	max	
WOBBLE input frequency	$f_{WOBBLE}$	Normal-speed mode	-	22.05	-	kHz
		Double-speed mode	-	44.1	-	
VCO input frequency	$f_{VCO}$	Normal-speed mode	-	$16 \times f_{WOBBLE}$	-	kHz
		Double-speed mode	-	$8 \times f_{WOBBLE}$	-	
BICK output frequency	$f_{BICK}$	Normal-speed mode	-	$f_{VCO} + 56$	-	kHz
		Double-speed mode	-	$f_{VCO} + 28$	-	
PLOAD output frequency	$f_{PLOAD}$	Normal-speed mode	-	$f_{VCO} + 16$	-	kHz
		Double-speed mode	-	$f_{VCO} + 8$	-	
VCO to PLOAD output delay time	$t_{VCOPLL}$		-	-	60	ns
VCO to PHASE output delay time	$t_{VCOPHA}$		-	-	60	ns
WOBBLE to PHASE output delay time	$t_{WOBBPHA}$		-	-	60	ns
BICK LOW-level pulsewidth	$t_{BICKL}$	Normal-speed mode	-	$24 + f_{VCO}$	-	ms
		Double-speed mode	-	$12 + f_{VCO}$	-	
BICK HIGH-level pulsewidth	$t_{BICKH}$	Normal-speed mode	-	$32 + f_{VCO}$	-	ms
		Double-speed mode	-	$16 + f_{VCO}$	-	
BIDATA to BICK output delay time	$t_{BIDBICK}$		-70	-	70	ns

Analog PLL waveforms

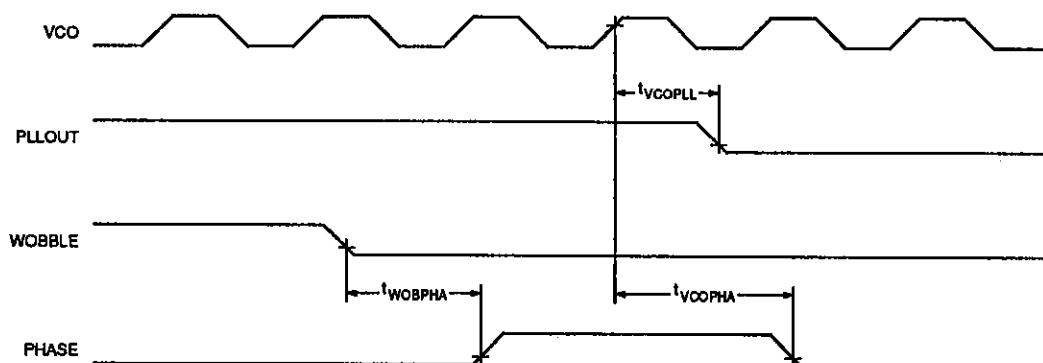

**Bi-phase clock and data waveforms**

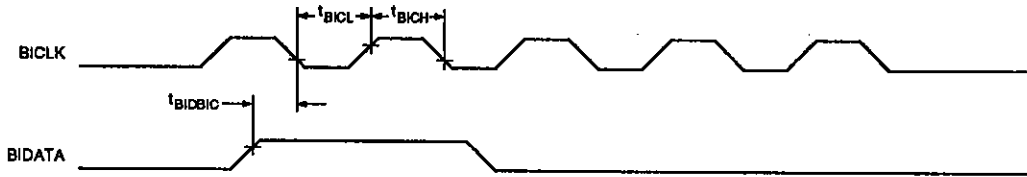

**Digital PLL**

$V_{DD} = 4.5 \text{ to } 5.5 \text{ V}$ ,  $V_{SS} = 0 \text{ V}$ ,  $T_a = -30 \text{ to } 70 \text{ }^\circ\text{C}$ ,  $V_{IL} = V_{OL} = 0.8 \text{ V}$ ,  $V_{IH} = V_{OH} = 2.2 \text{ V}$

Parameter	Symbol	Conditions	Ratings			Unit
			min	typ	max	
WOBBLE input frequency	$f_{WOBBLE}$	Normal-speed mode	-	22.05	-	kHz
		Double-speed mode	-	44.1	-	
BICLK output frequency	$f_{BICLK}$		-	$2 \times f_{PLOW} + 7$	-	kHz
PLLOW output frequency	$f_{PLOW}$		-	$\leq f_{WOBBLE}$	-	kHz

**ATIP decoder**

$V_{DD} = 4.5 \text{ to } 5.5 \text{ V}$ ,  $V_{SS} = 0 \text{ V}$ ,  $T_a = -30 \text{ to } 70 \text{ }^\circ\text{C}$ ,  $V_{IL} = V_{OL} = 0.8 \text{ V}$ ,  $V_{IH} = V_{OH} = 2.2 \text{ V}$

Parameter	Symbol	Conditions	Ratings			Unit
			min	typ	max	
BICLKIN input frequency	$f_{BICLKIN}$		-	$f_{BICLK}$	-	kHz
BIDATAIN to BICLKIN setup time	$t_{BICS}$		10	-	-	ns
BIDATAIN to BICLKIN hold time	$t_{BIDH}$		10	-	-	ns
BICLKIN to ERROR output delay time	$t_{BICERR}$		-	-	60	ns
ATIPCLK output clock frequency	$f_{ATIPCLK}$		-	$f_{SVCLK}$	-	kHz
BICLKIN to ATIPCLK output delay time	$t_{BICATI}$		-	-	60	ns

**ATIP decoder waveforms**

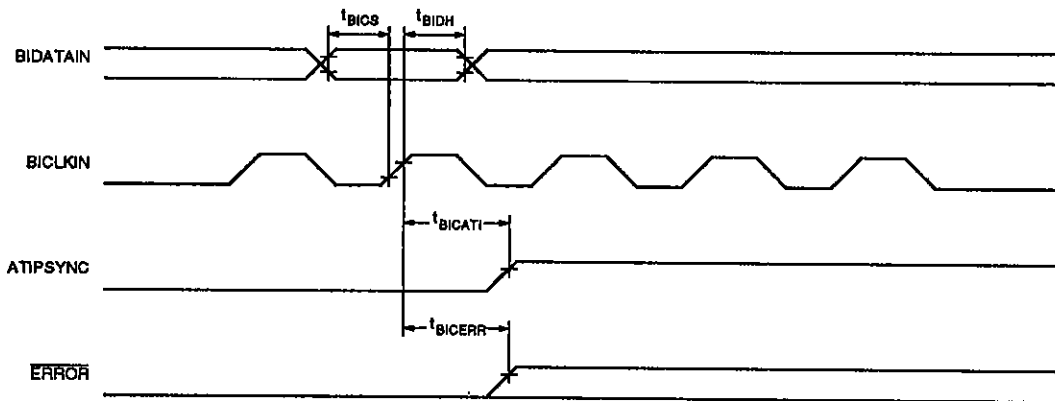

**CLV servocontroller**

$V_{DD} = 4.5$  to  $5.5$  V,  $V_{SS} = 0$  V,  $T_a = -30$  to  $70$  °C,  $V_{IL} = V_{OL} = 0.8$  V,  $V_{IH} = V_{OH} = 2.2$  V

Parameter	Symbol	Conditions	Ratings			Unit
			min	typ	max	
SVCLKIN input frequency	$f_{SVCLKIN}$		-	$f_{SVCLK}$	-	kHz
PLLOUTIN input frequency	$f_{PLLOUTIN}$		-	$f_{PLLOUT}$	-	kHz
ROUGH input frequency	$f_{ROUGH}$		-	$f_{PLLOUT}$	-	kHz

**Functional Description**

**CPU Interface**

The CPU interface uses the Sanyo C<sup>2</sup>B serial bus format. The CPU inputs commands to the LC89582, and the LC89582 outputs data to the CPU.

The interface waveforms are shown in figures 1 to 4. When CCB is HIGH, command input and output data

are preceded by eight address bits, B0 to B3 and A0 to A3, as shown in figures 2 and 4. The command input address is 7AH, and the data output address, 7BH. When CCB is LOW, the address bits are not used.

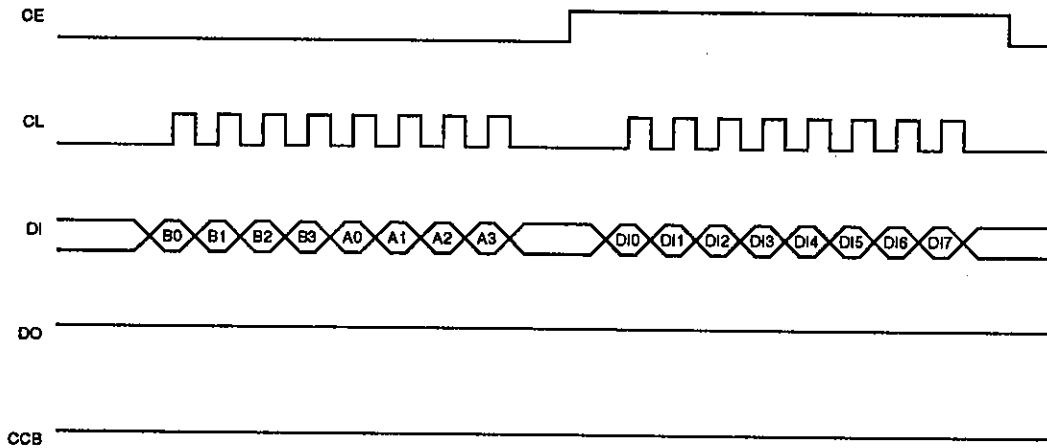

Figure 1. Command input format when CCB is HIGH

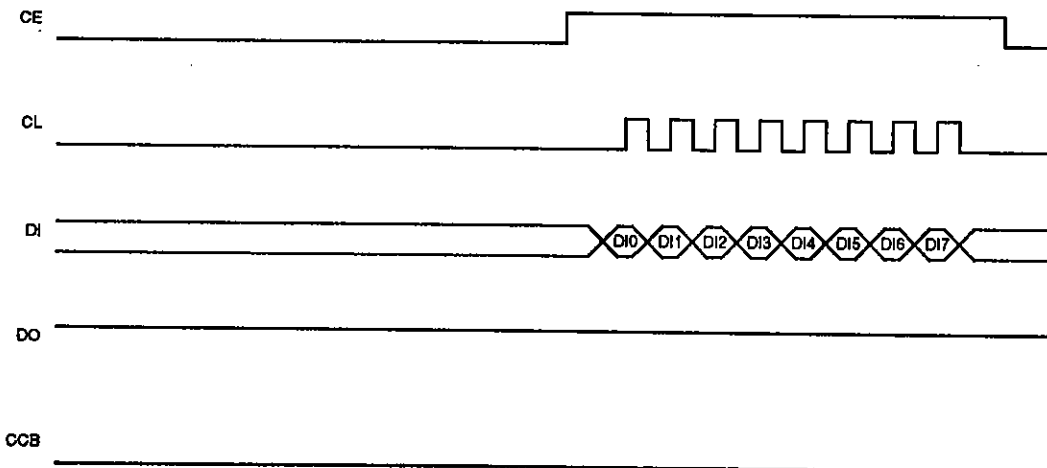

Figure 2. Command input format when CCB is LOW



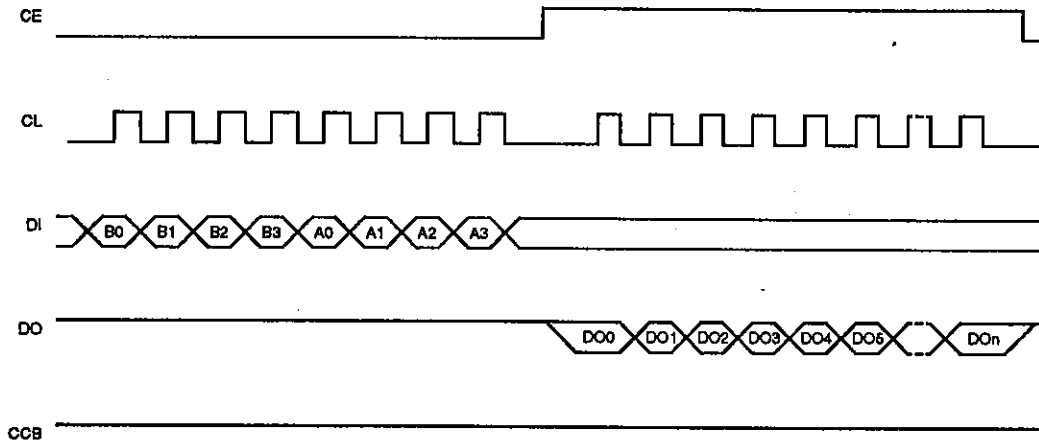

Figure 3. Data output format when CCB is HIGH

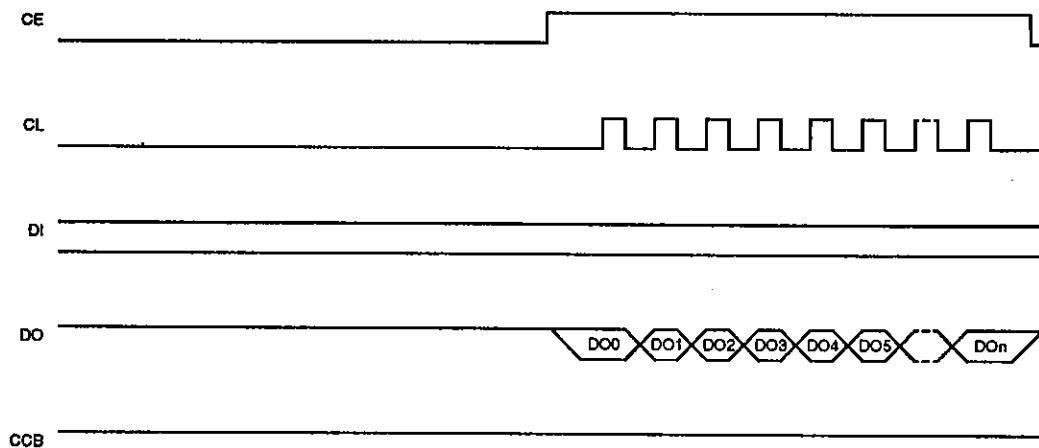

Figure 4. Data output format when CCB is LOW

The commands comprise four address and four data bits as shown in table 1.

Table 1. Command format

Address				Register data			
D7	D6	D5	D4	D3	D2	D1	D0
0	0	0	0	RESET	DRES	PRTCT	WS
0	0	0	1	0	0	0	ASWCPU
1	0	0	0	MA3	MA2	MA1	MA0
1	1	x	x	Test data			

**Note**

x = don't care

The data bits correspond to LC89582 internal registers. The data bit functions are explained in the following sections.

**RESET**

Setting this bit to 1 resets all circuits except the command registers. The initial value is 0.

**DRES**

Setting this bit to 1 resets the ATIP sync detector circuit. The initial value is 0.

**PRTCT**

Setting this bit to 1 turns the ATIP sync detector interpolation protection ON. The initial value is 0.

**WS**

Setting this bit to 1 turns double-speed mode ON. The initial value is 0.

**MA0 to MA3**

These bits select the monitor data for output to the CPU. The data formats are shown in table 2.

**ASWCPU**

This bit is used in combination with the ASW input to control the on-chip analog switches. The initial value is 1.

Table 2. Monitor data

MA3	MA2	MA1	MA0	Monitor data
0	0	0	0	DO0 = CRC, DO1 to DO6 = 0, DO7 = RSTSYS
0	0	0	1	DO0 = CRC, DO1 to DO24 = ATIP data
0	0	1	0	DO0 to DO23 = ATIP data

**Notes**

- RSTSYS RESET register value
- CRC CRC data value
- ATIP 24-bit ATIP data. Output lsb first data

**Timing Generator**

This circuit generates  $f_{SVCLK}$ , which is the digital PLL and CLV servocontroller reference frequency. The nor-

mal-speed mode and double-speed mode SVCLK waveforms are shown in figures 5 and 6, respectively.

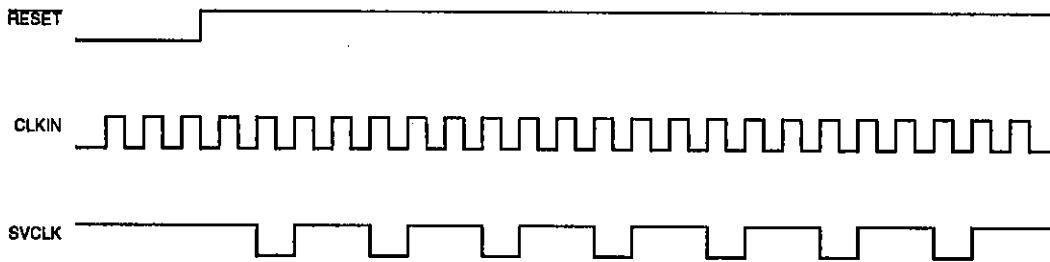

Figure 5. Normal-speed mode SVCLK waveform

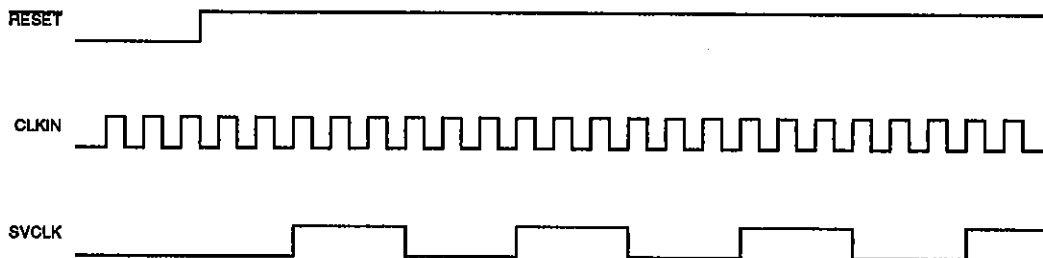

Figure 6. Double-speed mode SVCLK waveform

**PLL Circuit**

The LC89582 uses either the internal, digital PLL or an external, analog PLL to generate the bi-phase data and clock from the WOBBLE input signal. Note that the internal PLL does not require additional external components whereas an external PLL does.

However, an external PLL does allow adjustment of PLL performance. The WOBBLE and bi-phase data and clock waveforms are shown in figure 7, and the analog PLL waveforms, in figure 8.

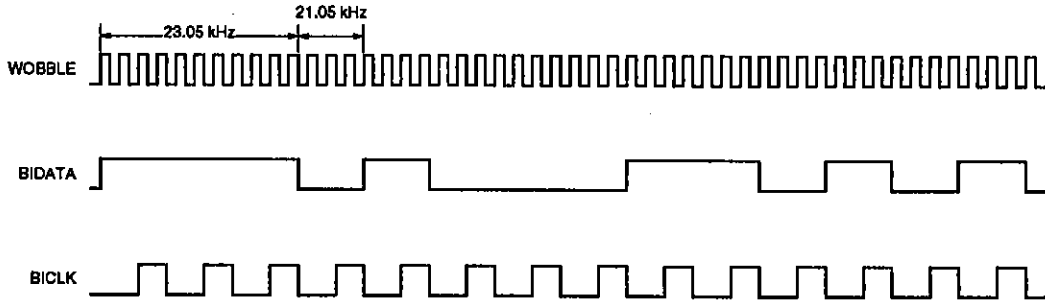

Figure 7. Bi-phase waveforms

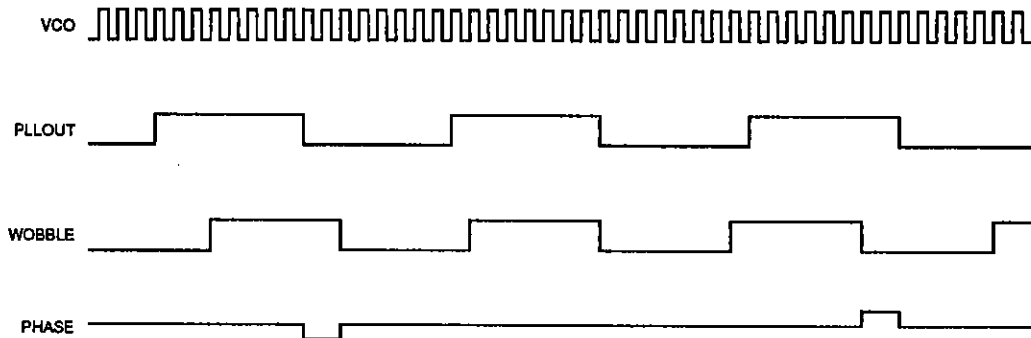

Figure 8. Analog PLL waveforms

**ATIP Decoder**

The ATIP decoder generates the 24-bit ATIP data and the ATIPSYNC output signal using the bi-phase data and clock generated by the PLL circuit. The ATIP

decoder input and output waveforms are shown in figure 9, and the ATIP sync detector flowchart, in figure 10.

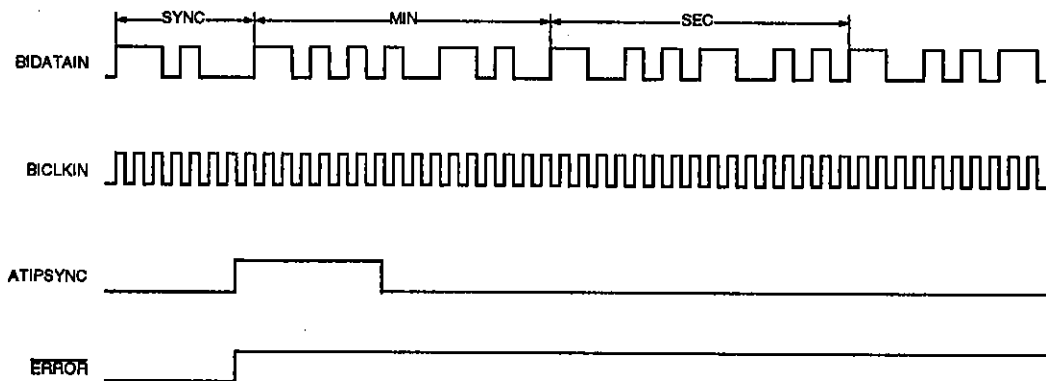

Figure 9. ATIP decoder waveforms

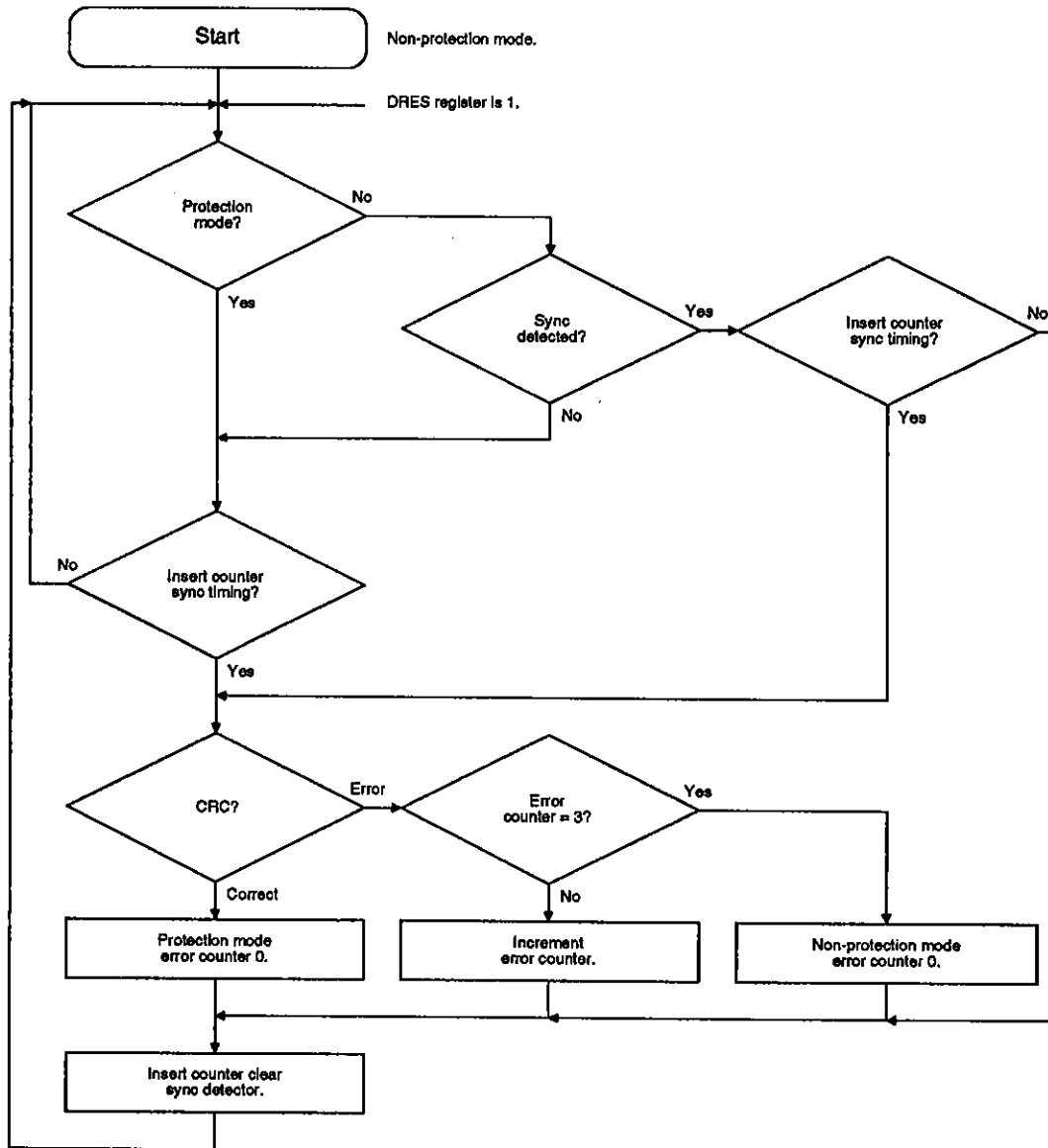

Figure 10. ATIP sync detector flowchart

### CLV Servocontroller Outputs

The servocontroller outputs are LOCK, CLV+ and CLV-. LOCK is HIGH when the input clock frequency (from either PLLOUTIN or ROUGH) is within 15% of the SVCLKIN reference frequency.

The CLV+ and CLV- output mode is selected using S/S. When S/S is LOW, CLV+ and CLV- function as disk motor control outputs as shown in table 3.

Table 3. CLV servocontroller modes when S/S is LOW

Internal mode	Condition	CLV+	CLV-	LOCK
Rough servo	Velocity too low	HIGH	LOW	LOW
	Velocity too high	LOW	HIGH	LOW
Phase control	Velocity is correct. The input clock is locked to SVCLKIN.	PWM	PWM	HIGH

When S/S is HIGH, the phase and frequency error signals, MDP and MDS, are output on CLV+ and CLV-, respectively. In this mode, CLV- is HIGH when the reference clock leads the input clock, is LOW when the reference clock lags the input clock, and is high-impedance when they are in phase. CLV+ functions as a clock output. When the reference clock frequency is higher than the input clock frequency, the CLV+ signal has a low duty cycle, and when lower than the input clock frequency, a high duty cycle.

## Analog Switches

The built-in analog switches are controlled by the ASW input and the ASWCPU register as shown in table 4.

Table 4. Analog switches

ASW	ASWCPU	Analog switch output		
		AAO	ABO	ABO1
LOW	0	AAI0	ABI0	High impedance
LOW	1	AAI0	ABI0	High impedance
HIGH	0	AAI0	ABI0	High impedance
HIGH	1	AAI1	AAI1	ABI1

- No products described or contained herein are intended for use in surgical implants, life-support systems, aerospace equipment, nuclear power control systems, vehicles, disaster/crime-prevention equipment and the like, the failure of which may directly or indirectly cause injury, death or property loss.
- Anyone purchasing any products described or contained herein for an above-mentioned use shall:
  - ① Accept full responsibility and indemnify and defend SANYO ELECTRIC CO., LTD., its affiliates, subsidiaries and distributors and all their officers and employees, jointly and severally, against any and all claims and litigation and all damages, cost and expenses associated with such use;
  - ② Not impose any responsibility for any fault or negligence which may be cited in any such claim or litigation on SANYO ELECTRIC CO., LTD., its affiliates, subsidiaries and distributors or any of their officers and employees jointly or severally.
- Information (including circuit diagrams and circuit parameters) herein is for example only; it is not guaranteed for volume production. SANYO believes information herein is accurate and reliable, but no guarantees are made or implied regarding its use or any infringements of intellectual property rights or other rights of third parties.