

MITSUBISHI RF POWER TRANSISTOR 2SC2131

NPN EPITAXIAL PLANAR TYPE

DESCRIPTION

2SC2131 is a silicon NPN epitaxial planar type transistor designed for RF power amplifiers in UHF band mobile radio applications.

FEATURES

- High power gain: $G_{pe} \geq 6.7\text{dB}$
@ $V_{CC} = 13.5\text{V}$, $P_O = 1.4\text{W}$, $f = 500\text{MHz}$
- TO-39 metal sealed package for high reliability.
- Emitter ballasted construction, gold metallization for good performances.
- Emitter electrode is connected electrically to the case.

APPLICATION

1 watt power amplifiers in UHF band mobile radio applications and driver amplifiers in general.

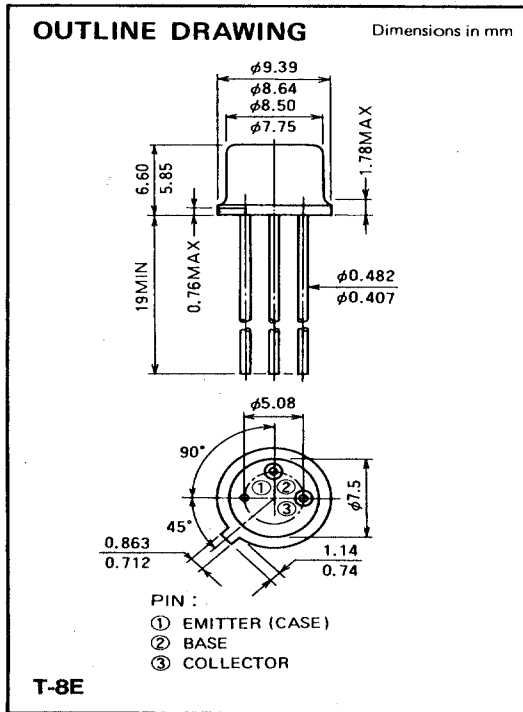

ABSOLUTE MAXIMUM RATINGS ($T_C = 25^\circ\text{C}$ unless otherwise specified)

Symbol	Parameter	Conditions	Ratings	Unit
V_{CBO}	Collector to base voltage		40	V
V_{EBO}	Emitter to base voltage		4	V
V_{CEO}	Collector to emitter voltage	$R_{BE} = \infty$	18	V
I_C	Collector current		0.6	A
P_C	Collector dissipation	$T_a = 25^\circ\text{C}$	0.8	W
		$T_C = 25^\circ\text{C}$	4	W
T_j	Junction temperature		175	$^\circ\text{C}$
T_{stg}	Storage temperature		-55 to 175	$^\circ\text{C}$
R_{th-a}	Thermal resistance	Junction to ambient	187.5	$^\circ\text{C}/\text{W}$
R_{th-c}		Junction to case	37.5	$^\circ\text{C}/\text{W}$

Note. Above parameters are guaranteed independently.

ELECTRICAL CHARACTERISTICS ($T_C = 25^\circ\text{C}$ unless otherwise specified)

Symbol	Parameter	Test conditions	Limits			Unit
			Min	Typ	Max	
$V_{(BR)EBO}$	Emitter to base breakdown voltage	$I_E = 1\text{mA}$, $I_C = 0$	4			V
$V_{(BR)CBO}$	Collector to base breakdown voltage	$I_C = 5\text{mA}$, $I_E = 0$	40			V
$V_{(BR)CEO}$	Collector to emitter breakdown voltage	$I_C = 50\text{mA}$, $R_{BE} = \infty$	18			V
I_{CBO}	Collector cutoff current	$V_{CB} = 25\text{V}$, $I_E = 0$			100	μA
I_{EBO}	Emitter cutoff current	$V_{EB} = 3\text{V}$, $I_C = 0$			100	μA
h_{FE}	DC forward current gain*	$V_{CE} = 10\text{V}$, $I_C = 0.1\text{A}$	10	50	180	—
P_O	Output power	$V_{CC} = 13.5\text{V}$, $P_{in} = 0.3\text{W}$, $f = 500\text{MHz}$	1.4	1.6		W
η_C	Collector efficiency		50	60		%

Note. * Pulse test, $P_W = 150\mu\text{s}$, duty=5%.

Above parameters, ratings, limits and conditions are subject to change.

MITSUBISHI RF POWER TRANSISTOR
2SC2131

NPN EPITAXIAL PLANAR TYPE

TEST CIRCUIT

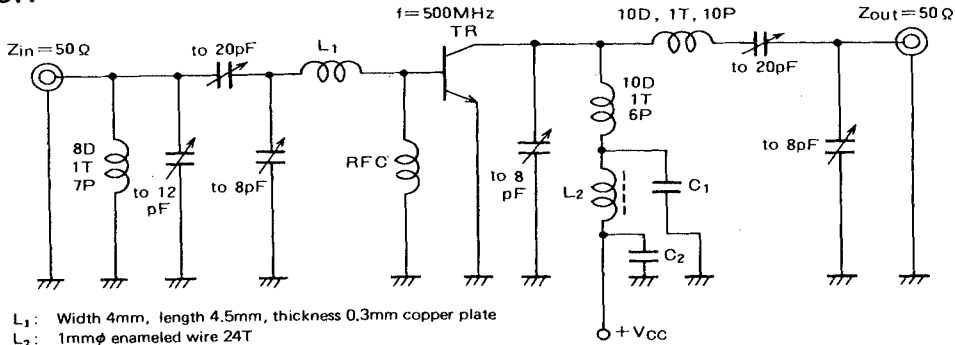

- L₁: Width 4mm, length 4.5mm, thickness 0.3mm copper plate
- L₂: 1mmφ enameled wire 24T
- RFC: 0.3mmφ enameled wire 25T to 30T
- C₁: 50pF, 100pF, 2200pF, 0.005μF, 0.0022μF in parallel
- C₂: 0.02μF, 0.047μF, 0.47μF in parallel
- Notes: Coils are made from 1.5mmφ silver plated copper wire except L₁, L₂ & RFC
- D: Inner diameter of coil P: Pitch of coil
- T: Turn number of coil Coil dimensions in milli-meter

TYPICAL PERFORMANCE DATA

COLLECTOR DISSIPATION VS. AMBIENT TEMPERATURE

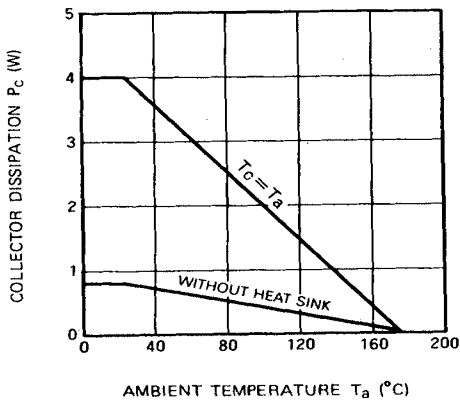

COLLECTOR CURRENT VS. COLLECTOR TO EMITTER VOLTAGE

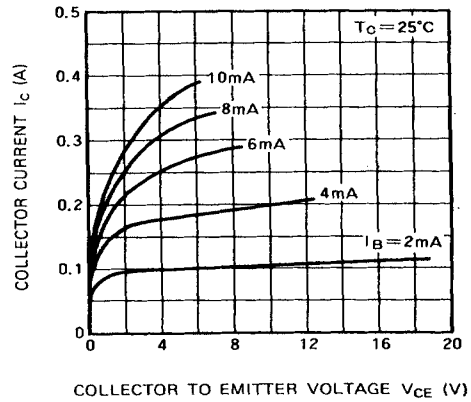

COLLECTOR TO EMITTER BREAKDOWN VOLTAGE VS. BASE TO EMITTER RESISTANCE

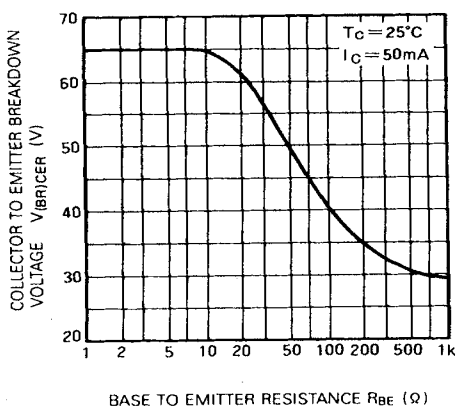

DC CURRENT GAIN VS. COLLECTOR CURRENT

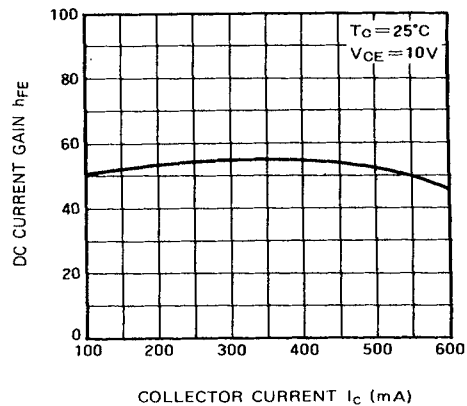

MITSUBISHI RF POWER TRANSISTOR
2SC2131

NPN EPITAXIAL PLANAR TYPE

COLLECTOR OUTPUT CAPACITANCE VS. COLLECTOR TO BASE VOLTAGE

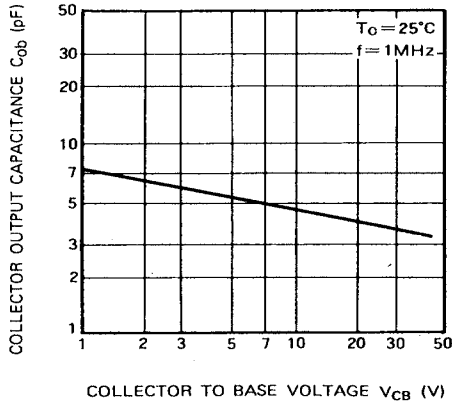

OUTPUT POWER, COLLECTOR EFFICIENCY VS. INPUT POWER

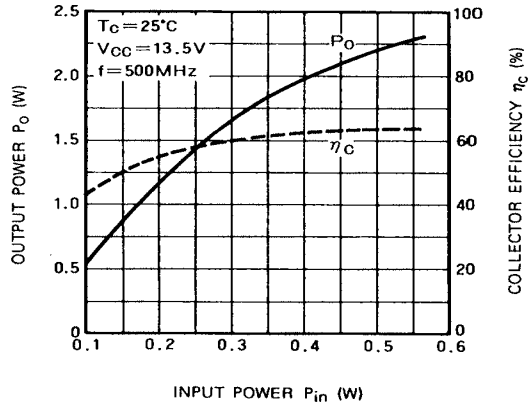

OUTPUT POWER VS. COLLECTOR SUPPLY VOLTAGE

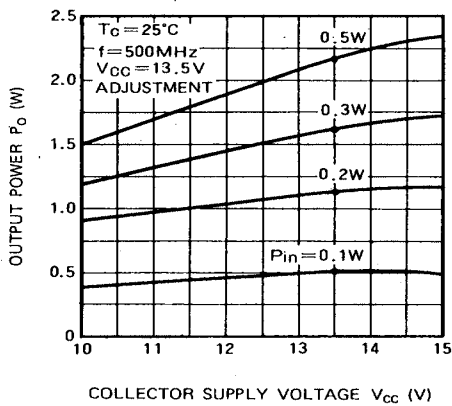

TRIPLER OUTPUT POWER, COLLECTOR EFFICIENCY VS. INPUT POWER

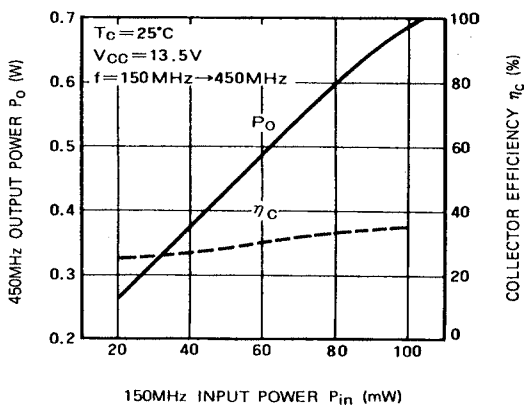

APPLICATION CIRCUIT TRIPLER CIRCUIT DIAGRAM (150MHz → 450MHz)

