

NE85001 SERIES

1 W C-BAND POWER GaAs FET N-CHANNEL GaAs MES FET

DESCRIPTION

The NE8500199 Power GaAs FET covers 2 GHz to 10 GHz frequency range for commercial amplifier, oscillator applications and so on.

NE8500100 is the two-cells recessed gate chip used in '99' package.

The device incorporates Ti-Al gate and silicon dioxide glassivation. To reduce the thermal resistance, the device has a PHS. (Plated Heat Sink)

NEC's stringent quality assurance and test procedures assure the highest reliability and performance.

FEATURES

- Class A operation
- High power output
- High reliability

PHYSICAL DIMENSIONS NE8500100 (CHIP) (unit: μm)

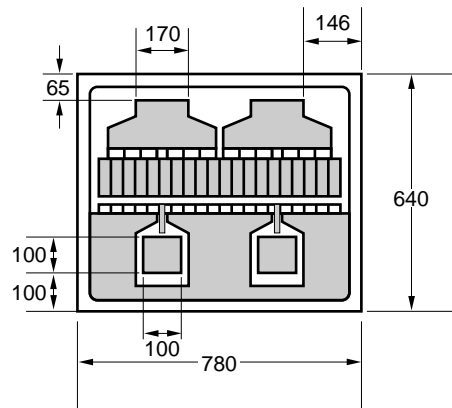

SELECTION CHART

PART NUMBER	FORM	PERFORMANCE SPECIFIED		
		Pout (**) (dBm)	GL (**) (dB)	USABLE FREQUENCY (GHz)
NE8500100(*) NE8500100-WB NE8500100-RG	chip	28.5 min	9.0 typ	2.0 to 10
NE8500199	package	28.5 min	9.0 typ	2.0 to 10

* WB, RG indicate a type of containers for chips.

WB: black carrier, RG: ring, : gel-pack,

** Specified at the condition at the last page.

PACKAGE CODE-99 (unit: mm)

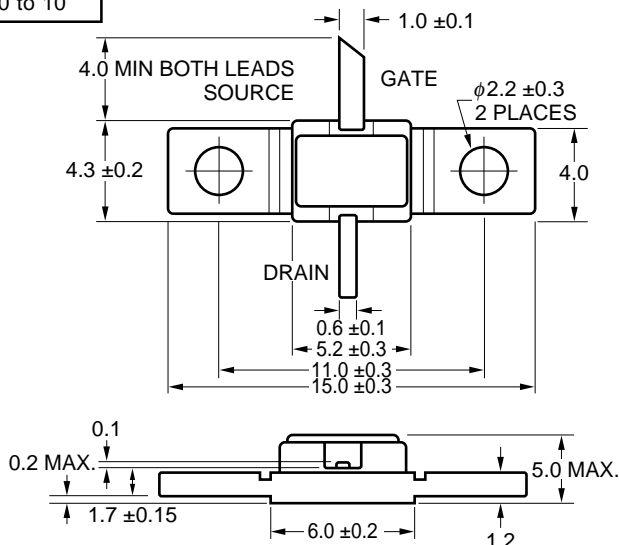

ABSOLUTE MAXIMUM RATINGS (T_A = 25 °C)

Drain to Source Voltage	V _{DSX}	15	V
Gate to Drain Voltage	V _{GDX}	-18	V
Gate to Source Voltage	V _{G SX}	-12	V
Total Power Disipation(*)	P _T	6.0	W
Drain Current	I _D	1.12	A
Gate Current	I _G	6.0	mA
Channel Temperature	T _{ch}	175	°C
Storage Temperature	T _{stg}	-65 to 175	°C

*T_C = 25 °C

RECOMMENDING OPERATION RANDGE

CHARACTERISTIC	SYMBOL	MIN.	TYP.	MAX.	UNIT
Drain to Source Voltage	V _{DS}	9	-	10	V
Channel Temperature	T _{ch}	-	-	130	°C
Input Power	G _{comp}	-	-	3	dBcomp
Gate Resistance	R _g	-	-	1	kΩ

ELECTRICAL CHARACTERISTICS (T_A = 25 °C)

CHARACTERISTIC	SYMBOL	MIN.	TYP.	MAX.	UNIT	TEST CONDITIONS
Saturated Drain Current	I _{DSS}	430	-	860	mA	V _{ds} = 2.5 V, V _{gs} = 0 V
Pinch-off Voltage	V _P	-3.0	-	-1.0	V	V _{ds} = 2.5 V, I _{ds} = 4 mA
Transconductance	g _m	-	300	-	mS	V _{ds} = 2.5 V, I _{ds} = I _{DSS}
Thermal Resistance	R _{th}	-	-	30	°C/W	

PERFORMANCE SPECIFICATIONS (T_A = 25 °C)

PART NUMBER		NE8500100 NE8500100-WG NE8500100-RG			NE8500199			UNIT	TEST CONDITIONS
PACKAGE CODE		CHIP			99				
CHARACTERISTIC	SYMBOL	MIN.	TYP.	MAX.	MIN.	TYP.	MAX.		
Output Power	P _o	28.5	-	-	28.5	-	-	dBm	f = 7.2 GHz V _{ds} = 10 V I _{ds} = 200 mA set R _g = 1 kΩ Pin = 21.0 dBm(*)
Gate to source Current	I _{gs}	-2.0	-	2.0	-2.0	-	2.0	mA	
Linear Gain	G _L	-	9	-	-	9	-	dB	Pin ≤ 11 dBm (**)

* Pin for Pout specification.

** The same conditions as the above except this.

TYPICAL CHARACTERISTICS ($T_A = 25\text{ }^\circ\text{C}$)

NE8500199

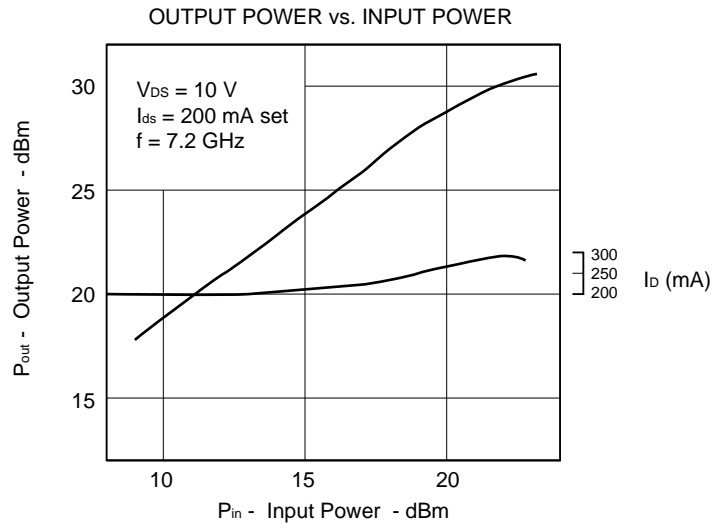

S-PARAMETER

V_{DS} = 10 V, I_{DS} = 200 mA, V_{GS} = -1.260 V, I_G = 0.0 mA, R_G = 1 kΩ

FREQUENCY GHz	S ₁₁		S ₂₁		S ₁₂		S ₂₂	
	MAG	ANG	MAG	ANG	MAG	ANG	MAG	ANG
0.100	0.990	-22.7	14.418	165.5	0.007	70.1	0.065	-64.6
0.500	0.916	-91.1	10.211	123.3	0.024	47.7	0.175	-126.4
1.000	0.869	-132.1	6.444	94.8	0.031	33.6	0.221	-149.1
1.500	0.851	-152.9	4.610	76.6	0.034	29.0	0.241	-159.2
2.000	0.840	-166.1	3.591	61.9	0.038	28.1	0.260	-165.6
2.500	0.831	-175.9	2.975	49.1	0.042	26.7	0.278	-170.8
3.000	0.826	176.0	2.601	37.3	0.047	25.4	0.296	-174.6
3.500	0.824	168.8	2.341	26.0	0.053	27.4	0.313	-177.8
3.600	0.825	167.5	2.291	23.4	0.055	27.0	0.317	-179.2
3.700	0.825	166.0	2.253	20.7	0.056	26.5	0.323	179.8
3.800	0.827	164.4	2.230	18.1	0.059	26.8	0.333	179.4
3.900	0.829	162.8	2.187	16.1	0.063	26.5	0.340	178.7
4.000	0.829	161.0	2.127	13.4	0.066	25.4	0.345	176.3
4.200	0.821	157.2	2.053	8.6	0.072	20.1	0.353	171.0
4.400	0.808	153.9	1.976	5.6	0.074	16.8	0.343	167.3
4.500	0.803	152.5	1.963	3.4	0.075	15.2	0.337	166.2
4.600	0.799	151.0	1.970	0.8	0.077	13.9	0.340	164.8
4.800	0.790	147.9	1.944	-3.1	0.080	12.6	0.341	163.2
5.000	0.784	144.7	1.929	-8.6	0.084	9.3	0.340	159.8
5.200	0.777	141.4	1.923	-12.8	0.089	7.4	0.349	158.6
5.400	0.771	137.7	1.897	-18.5	0.093	4.5	0.347	155.6
5.500	0.767	135.9	1.916	-20.7	0.097	3.1	0.358	154.2
5.600	0.764	133.9	1.916	-22.7	0.100	1.8	0.363	154.5
5.800	0.758	130.1	1.887	-28.5	0.105	-1.9	0.358	151.6
6.000	0.751	125.8	1.928	-33.5	0.113	-4.8	0.381	149.5
6.200	0.742	121.3	1.896	-39.1	0.116	-8.0	0.369	146.8
6.400	0.731	116.6	1.951	-44.8	0.126	-11.6	0.397	144.2
6.500	0.726	114.1	1.951	-47.2	0.130	-13.2	0.396	144.2
6.600	0.721	111.6	1.936	-50.6	0.133	-15.9	0.387	141.8
6.800	0.707	106.1	1.973	-56.8	0.143	-20.4	0.411	138.6
7.000	0.689	100.2	1.957	-62.4	0.149	-23.9	0.402	137.1
7.200	0.676	93.9	2.004	-69.1	0.163	-28.9	0.424	133.8
7.400	0.657	87.1	2.002	-74.9	0.171	-33.3	0.425	132.3
7.500	0.649	83.4	2.013	-78.8	0.177	-36.8	0.431	129.4
7.600	0.640	79.9	2.045	-82.4	0.185	-39.6	0.448	127.2
7.800	0.621	71.8	2.042	-88.6	0.195	-45.0	0.452	123.8
8.000	0.604	63.2	2.067	-96.6	0.206	-51.8	0.465	117.2
8.200	0.590	53.4	2.078	-103.5	0.216	-57.8	0.478	112.7
8.400	0.584	42.7	2.088	-112.0	0.227	-65.4	0.492	104.8
8.500	0.577	37.0	2.102	-115.5	0.232	-68.0	0.500	102.7
8.600	0.574	31.2	2.083	-119.1	0.237	-71.2	0.501	100.1
8.800	0.570	18.8	2.088	-127.8	0.246	-78.3	0.519	93.0
9.000	0.571	5.9	2.072	-135.7	0.253	-84.7	0.534	87.2
9.200	0.583	-7.6	2.044	-144.6	0.264	-92.3	0.545	80.1
9.400	0.599	-21.4	2.040	-153.1	0.274	-99.3	0.568	73.6
9.500	0.611	-28.5	2.030	-157.9	0.277	-103.2	0.577	69.7
9.600	0.619	-35.9	2.008	-162.9	0.281	-107.4	0.583	65.8
9.800	0.631	-50.4	1.943	-173.2	0.284	-115.9	0.600	56.3
10.000	0.631	-62.9	1.812	177.3	0.280	-123.6	0.587	47.0

CHIP HANDLING**DIE ATTACHMENT**

Die attach can be accomplished with a Au-Sn (300 ± 10 °C) performs in a forming gas environment. Epoxy die attach is not recommended.

BONDING

Gate and drain bonding wires should be minimum length, semi-hard gold wire (3 - 8 % elongation) 30 microns or less in diameter.

Bonding should be performed with a wedge tip that has a taper of approximately 15 %.

Die attach and bonding time should be kept to a minimum. As a general rule, the bonding operation should be kept within a 280 °C _ 5 minute curve. If longer periods are required, the temperature should be lowered.

PRECAUTIONS

The user must operate in a clean, dry environment.

The chip channel is glassivated for mechanical protection only and does not preclude the necessity of a clean environment.

The bonding equipment should be periodically checked for sources of surge voltage and should be properly grounded at all times. In fact, all test and handling equipment should be grounded to minimize the possibilities of static discharge.

No part of this document may be copied or reproduced in any form or by any means without the prior written consent of NEC Corporation. NEC Corporation assumes no responsibility for any errors which may appear in this document.

NEC Corporation does not assume any liability for infringement of patents, copyrights or other intellectual property rights of third parties by or arising from use of a device described herein or any other liability arising from use of such device. No license, either express, implied or otherwise, is granted under any patents, copyrights or other intellectual property rights of NEC Corporation or others.

While NEC Corporation has been making continuous effort to enhance the reliability of its semiconductor devices, the possibility of defects cannot be eliminated entirely. To minimize risks of damage or injury to persons or property arising from a defect in an NEC semiconductor device, customer must incorporate sufficient safety measures in its design, such as redundancy, fire-containment, and anti-failure features.

NEC devices are classified into the following three quality grades:

"Standard", "Special", and "Specific". The Specific quality grade applies only to devices developed based on a customer designated "quality assurance program" for a specific application. The recommended applications of a device depend on its quality grade, as indicated below. Customers must check the quality grade of each device before using it in a particular application.

Standard: Computers, office equipment, communications equipment, test and measurement equipment, audio and visual equipment, home electronic appliances, machine tools, personal electronic equipment and industrial robots

Special: Transportation equipment (automobiles, trains, ships, etc.), traffic control systems, anti-disaster systems, anti-crime systems, safety equipment and medical equipment (not specifically designed for life support)

Specific: Aircrafts, aerospace equipment, submersible repeaters, nuclear reactor control systems, life support systems or medical equipment for life support, etc.

The quality grade of NEC devices in "Standard" unless otherwise specified in NEC's Data Sheets or Data Books. If customers intend to use NEC devices for applications other than those specified for Standard quality grade, they should contact NEC Sales Representative in advance.

Anti-radioactive design is not implemented in this product.