

ASSP For Power Supply Applications

BIPOLAR

Switching Regulator Controller (Supporting External Synchronization)

MB3789

■ DESCRIPTION

The MB3789 is a PWM (pulse width modulation) switching regulator controller supporting an external sync signal. The MB3789 incorporates two error amplifiers which can be used respectively for voltage control and current control, allowing the IC to serve as a DC/DC converter with current regulating functions.

The MB3789 is the ideal IC for supplying power to the back-lighting fluorescent tube for a liquid crystal display (LCD) device such as a camera-integrated VTR.

■ FEATURES

- Wide range of operating power supply voltages: 3 V to 18 V
- Low current consumption: 1.5 mA (Typ.)
- Wide input voltage range of error amplifier: -0.2 V to $V_{CC} - 1.8$ V
- Built-in two error amplifier
- Oscillator capable of operating with an external sync signal
- Built-in timer latch short protection circuit
- Variable dead time provides control over total operating range
- Output supporting a power MOSFET
- 16-pin SSOP package mountable at high density

■ PACKAGE

16-pin Plastic SSOP

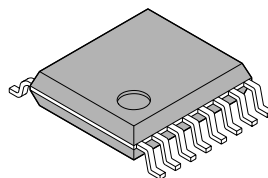

(FPT-16P-M05)

MB3789

■ PIN ASSIGNMENT

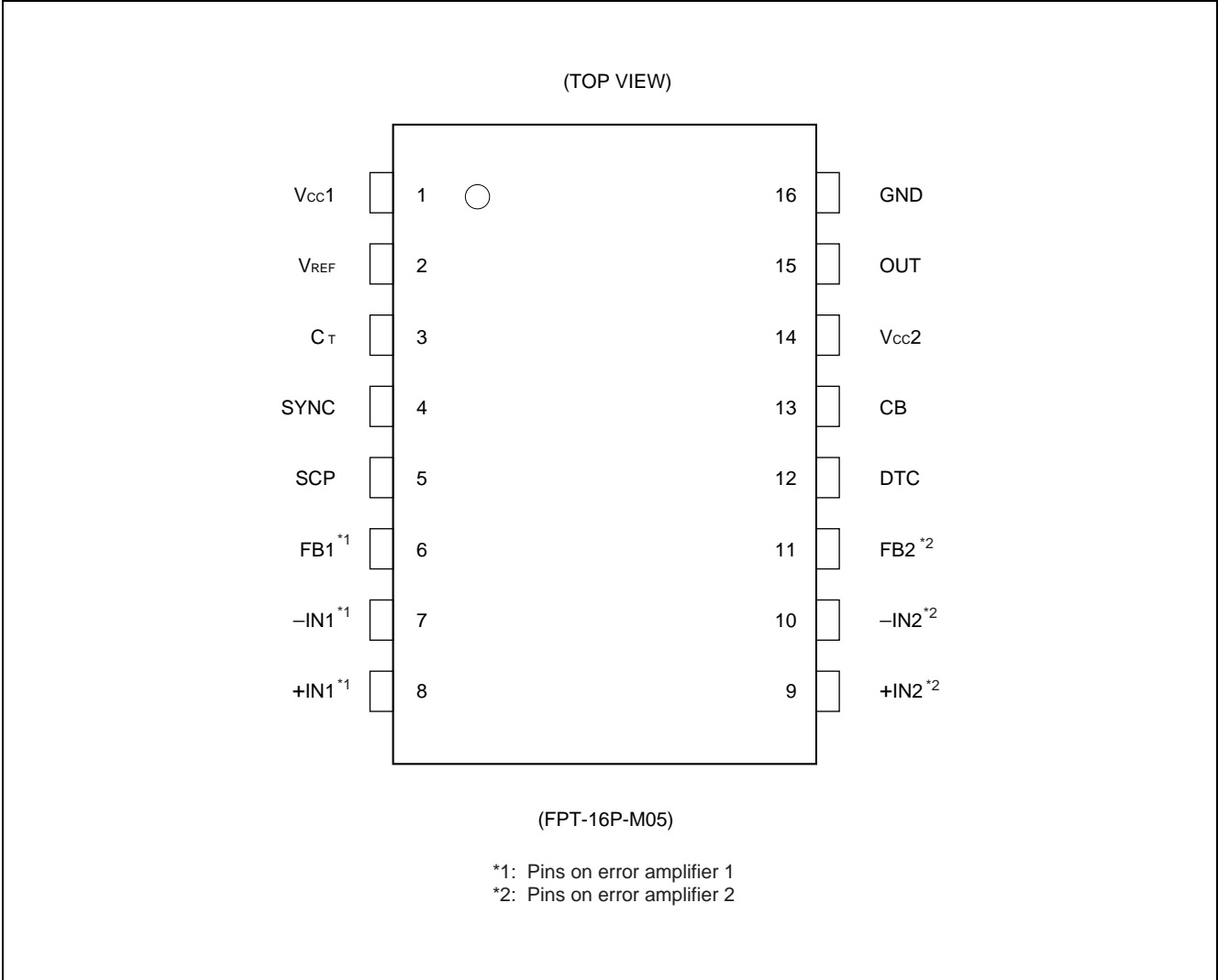

■ PIN DESCRIPTION

Pin no.	Pin symbol	I/O	Function	
I/O control unit	7	-IN1	I	Error amplifier 1 inverting input pin
	8	+IN1	I	Error amplifier 1 noninverting input pin
	6	FB1	O	Error amplifier 1 output pin
	10	-IN2	I	Error amplifier 2 inverting input pin
	9	+IN2	I	Error amplifier 2 noninverting input pin
	11	FB2	O	Error amplifier 2 output pin
	13	CB	—	Output bootstrap pin. Connect a capacitor between the CB and OUT pins to bootstrap the output transistor.
	5	SCP	—	Capacitor connection pin for short-circuit protection circuit
	12	DTC	I	Dead time control pin
	15	OUT	O	Totem-pole output pin
Sawtooth waveform oscillator	3	C _T	—	Sawtooth waveform frequency setting capacitor/resistor connection pin
	4	SYNC	I	External sync signal input pin
Power-supply circuit	1	V _{CC1}	—	Reference power supply, control circuit power-supply pin
	14	V _{CC2}	—	Output circuit power-supply pin
	2	V _{REF}	O	Reference voltage output pin
	16	GND	—	Ground pin

MB3789

■ BLOCK DIAGRAM

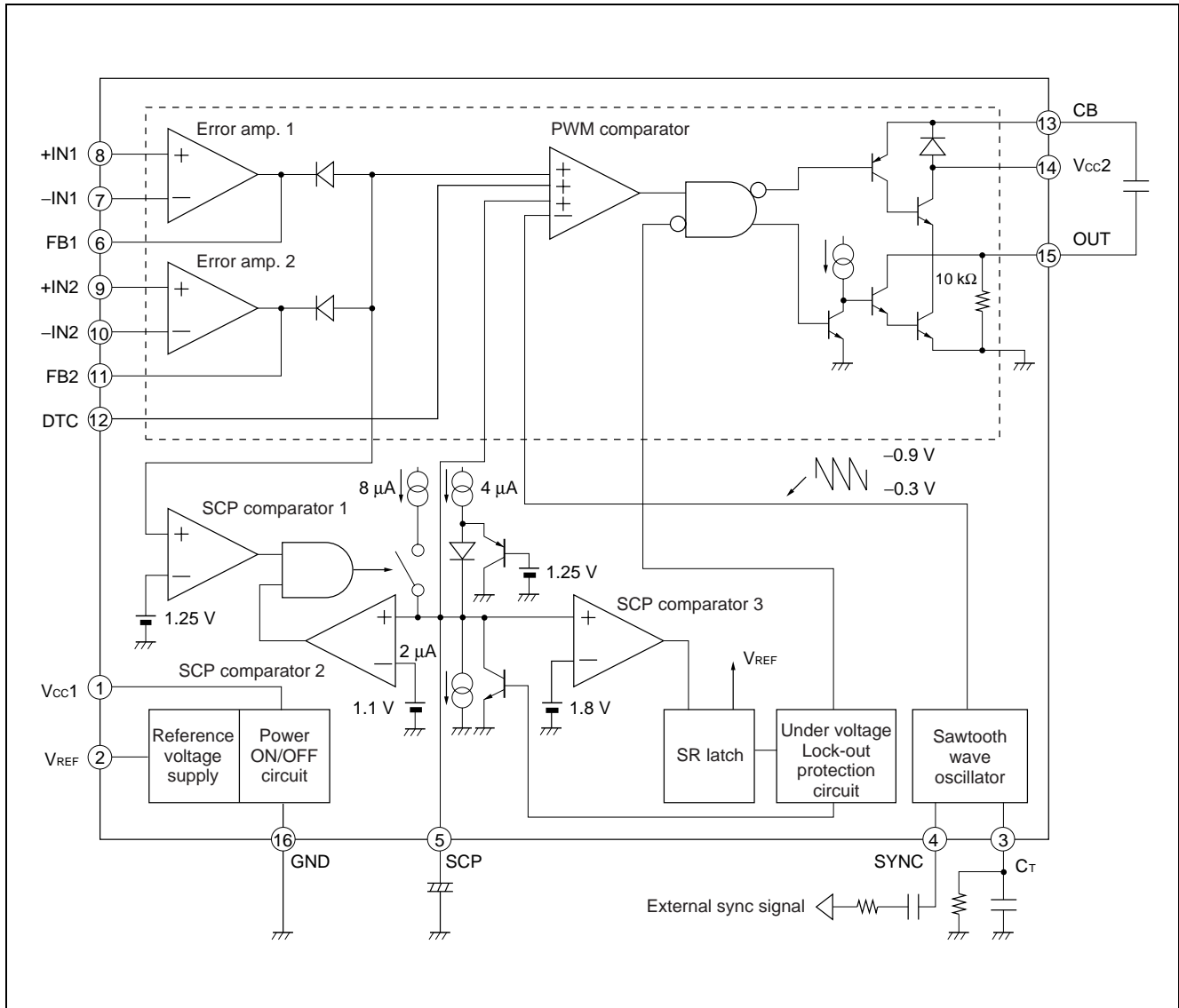

■ FUNCTIONAL DESCRIPTION

1. Switching Regulator Functions

(1) Reference voltage generator

The reference voltage generator uses the voltage supplied from the power supply pin (pin 1) to generate a temperature-compensated, reference voltage (about 2.50 V) as the reference supply voltage for the IC's internal circuitry.

The reference voltage can be output, up to 50 μ A, to an external device through the V_{REF} pin (pin 2).

This regulated reference voltage can be used as the reference voltage for the switching regulator and also used for setting the dead time.

(2) Sawtooth waveform oscillator

With a timing capacitor and a timing resistor connected to the C_T pin (pin 3), the sawtooth waveform oscillator generates a sawtooth wave which remains stable even with supply voltage variations or temperature changes. The sawtooth wave is input to the PWM comparator. The amplitude of oscillating waveform is 0.3 V to 0.9 V.

In addition, the oscillator can be used for external synchronization, where it generates a sawtooth waveform synchronous to the input signal from the SYNC pin (pin 4).

(3) Error amplifiers

The error amplifiers detect the output voltage from the switching regulator and outputs the PWM control signal. Since they support a wide range of in-phase input voltages from -0.2 V to " $V_{CC} - 1.8$ V", they can be set easily from an external power supply.

An arbitrary loop gain can be set by connecting a feedback resistor and capacitor from the error amplifier output pin to the inverting input pin, enabling stable phase compensation to the system.

The MB3789 can make a current-regulated DC/DC converter using the two internal error amplifiers respectively for voltage control and current control.

(4) PWM comparator

The PWM comparator is a voltage comparator with one inverting input and three noninverting inputs, serving as a voltage-pulse width converter for controlling the output duty depending on the input voltage.

The PWM comparator turns on the output transistor during the interval in which the sawtooth wave voltage level is lower than the voltage levels at all of the error amplifier output pins, the SCP pin (pin 5), and at the DTC pin (pin 12).

(5) Output circuit

The output circuit is a power MOSFET driven, output circuit in a totem-pole configuration. It can drive the gate voltage up to near the supply voltage with a bootstrap capacitor connected between the OUT pin (pin 15) and CB pin (pin 13). (See "■ SETTING THE BOOTSTRAP CAPACITOR (C_{BS}).")

2. Protection Functions

(1) Timer-latch short-circuit protection circuit

SCP comparator 1 detects the output voltage levels of error amplifiers 1 and 2. When the output voltage level of either (or both) of the two error amplifiers reaches 1.25 V, the timer circuit is actuated to start charging the external protection-enable capacitor connected to the SCP pin (pin 5).

If the error amplifier output is not restored to the normal voltage level before the capacitor voltage reaches 1.8 V, the latch circuit is actuated to turn off the output transistor while making the dead time 100%.

To reset the actuated protection circuit, turn the power supply on back. (See "■ SETTING THE SOFT START/ SHORT-CIRCUIT DETECTION TIME.")

MB3789

(2) Low input voltage malfunction preventive circuit

The transient state or a momentary decrease in supply voltage, which occurs when the power supply is turned on, may cause errors in the control IC, resulting in breakdown or degradation of the system. The low input voltage malfunction preventive circuit detects the internal reference voltage level according to the supply voltage level and, if the input voltage is low, turn off the output transistor and maintains the SCP pin (pin 5) at 0 V while making the dead time 100%.

The circuit restores voltage supply when the supply voltage reaches its threshold voltage.

■ ABSOLUTE MAXIMUM RATINGS

(Ta = +25°C)

Parameter	Symbol	Condition	Rating		Unit
			Min.	Max.	
Power supply voltage	V _{CC}	—	—	20	V
Power dissipation	P _D	Ta ≤ +25°C	—	440*	mW
Operating temperature	T _{OP}	—	-30	+85	°C
Storage temperature	T _{STG}	—	-55	+125	°C

* : When mounted on a 10 cm-square double-side epoxy board.

WARNING: Semiconductor devices can be permanently damaged by application of stress (voltage, current, temperature, etc.) in excess of absolute maximum ratings. Do not exceed these ratings.

■ RECOMMENDED OPERATING CONDITIONS

(Ta = +25°C)

Parameter	Symbol	Condition	Value			Unit
			Min.	Typ.	Max.	
Power supply voltage	V _{CC1}	—	3.0	5.0	18	V
	V _{CC2}	—	—	6.0	18	V
Reference voltage output current	I _{OR}	—	-50	-30	—	μA
Error amp. input voltage	V _I	—	-0.2	—	V _{CC} - 1.8	V
Output current	I _{O+}	CB = 4700 pF, t ≤ 2 μs	-70	-40	—	mA
	I _{O-}	CB = 4700 pF, t ≤ 2 μs	—	40	70	mA
Timing resistance	R _T	—	10	39	200	kΩ
Timing capacitance	C _T	—	470	1000	6800	pF
Oscillation frequency	f _{OSC}	—	1	20	200	kHz
Operating temperature	T _{OP}	—	-30	+25	+85	°C

WARNING: The recommended operating conditions are required in order to ensure the normal operation of the semiconductor device. All of the device's electrical characteristics are warranted when the device is operated within these ranges.

Always use semiconductor devices within their recommended operating condition ranges. Operation outside these ranges may adversely affect reliability and could result in device failure.

No warranty is made with respect to uses, operating conditions, or combinations not represented on the data sheet. Users considering application outside the listed conditions are advised to contact their FUJITSU representatives beforehand.

MB3789

■ ELECTRICAL CHARACTERISTICS

(V_{CC1} = 5 V, V_{CC2} = 6 V, T_a = +25°C)

Parameter	Symbol	Condition	Value			Unit	
			Min.	Typ.	Max.		
Reference voltage block	Output voltage	V _{REF}	I _{OR} = 0 μA	2.400	2.500	2.600	V
	Output voltage temperature variation	ΔV _{REF} /V _{REF}	T _a = -30°C to +85°C*	—	0.2	2	%
	Input stability	Line	V _{CC} = 3.0 V to 18 V	—	1	10	mV
	Load stability	Load	I _{OR} = 0 μA to -50 μA	—	2	10	mV
	Short output current	I _{OS}	V _{REF} = 0 V	-700	-450	-300	μA
Under voltage lockout protection circuit	Threshold voltage	V _{TH}	—	—	2.15	2.62	V
		V _{TL}	—	1.62	1.90	—	V
	Hysteresis width	V _{HYS}	—	80	250	—	mV
	Reset voltage (V _{CC})	V _R	—	1.0	1.4	—	V
Soft start block	Charge current	I _{CHG}	V _{SCP} 0.9 V	-2.8	-2.0	-1.2	μA
	Threshold voltage	V _{T0}	Duty cycle = 0%	0.2	0.3	0.4	V
		V _{T100}	Duty cycle = 100%	0.8	0.9	1.0	V
Short circuit detection block	Threshold voltage	V _{TH}	—	1.70	1.80	1.90	V
	Input standby voltage	V _{STB}	—	1.15	1.25	1.35	mV
	Input latch voltage	V _I	—	—	50	100	mV
	Input source current	I _I	V _{SCP} = 1.5 V	-8.4	-6.0	-3.6	μA
Triangular waveform oscillator block	Oscillator frequency	f _{OSC}	C _T = 1000 pF, R _T = 39 kΩ	17	20	23	kHz
	Frequency voltage variation	Δf/f _{dv}	V _{CC} = 3 V to 18 V	—	1	10	%
	Frequency temperature variation	Δf/f _{dT}	T _a = -30°C to +85°C*	—	3	—	%
	Synchronous pin input current	I _{SYNC}	V _{THSY} = 5 V	0.9	1.3	2.2	mA
	Synchronous pin threshold voltage	V _{THSY}	—	0.65	0.75	0.85	V

* : Standard design value

(Continued)

MB3789

(Continued)

(V_{CC1} = 5 V, V_{CC2} = 6 V, T_a = +25°C)

Parameter	Symbol	Condition	Value			Unit	
			Min.	Typ.	Max.		
Error amplifier	Input offset voltage	V _{IO}	V _{FB} = 0.6 V	—	—	10	mV
	Input offset current	I _{IO}	V _{FB} = 0.6 V	—	—	100	nA
	Input bias current	I _B	V _{FB} = 0.6 V	-200	-30	—	nA
	Common mode input voltage range	V _{CM}	—	-0.2	—	V _{CC} - 0.8	V
	Common mode rejection ratio	C _{MRR}	—	60	100	—	dB
	Voltage gain	A _V	—	60	100	—	dB
	Frequency bandwidth	BW	A _V = 0 dB*	—	800	—	kHz
	Maximum output voltage range	V _{OM+}	—	V _{REF} - 0.3	2.4	—	V
		V _{OM-}	—	—	0.05	0.3	V
	Output sink current	I _{OM+}	V _{FB} = 0.6 V	30	60	—	μA
Output source current	I _{OM-}	V _{FB} = 0.6 V	—	-2	-0.6	mA	
Dead time control block	Threshold voltage	V _{T0}	Duty cycle = 0%	0.2	0.3	0.4	V
		V _{T100}	Duty cycle = 100%	0.8	0.9	1.0	V
	ON duty cycle	D _{tr}	V _{dt} = V _{REF} /4.2	45	55	65	%
Input bias current	I _{bd}	—	-500	-100	—	nA	
PWM comparator block	Threshold voltage	V _{T0}	Duty cycle = 0%	0.2	0.3	0.4	V
		V _{T100}	Duty cycle = 100%	0.8	0.9	1.0	V
	Input sink current	I _{IN+}	—	30	60	—	μA
Input source current	I _{IN-}	—	—	-2	-0.6	mA	
Output block	Output voltage	V _{OH}	CL = 2000 pF, CB = 4700 pF	5.5	6.0	—	V
		V _{OL}	CL = 2000 pF, CB = 4700 pF	—	1.1	1.4	V
General	Power supply current when output off	I _{CC1}	—	—	1.15	1.65	mA
		I _{CC2}	—	—	350	500	μA

* : Standard design value

MB3789

TYPICAL CHARACTERISTICS

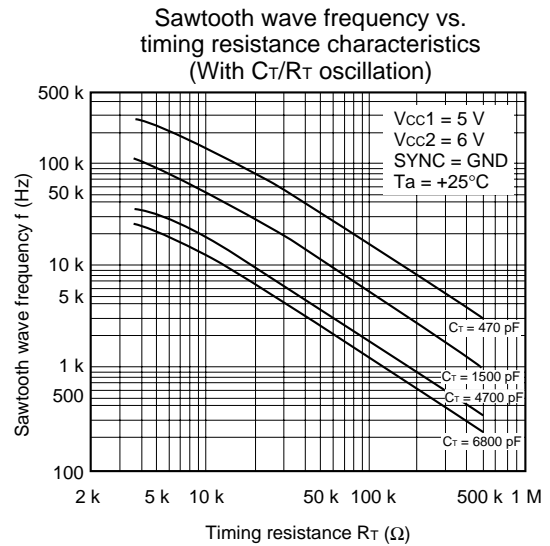
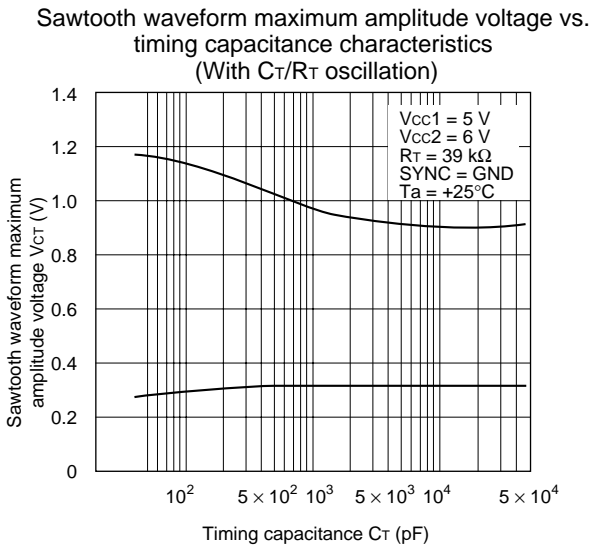
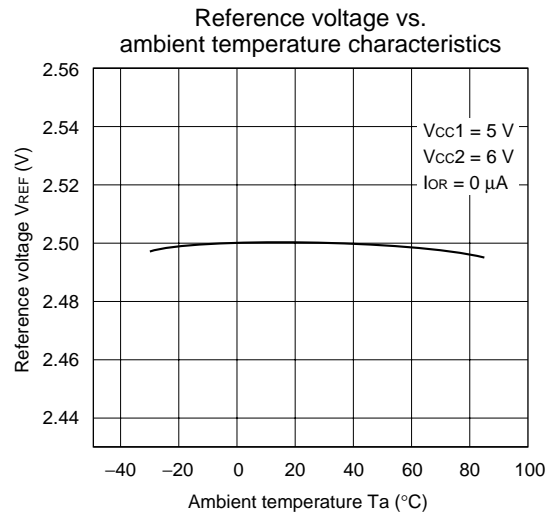
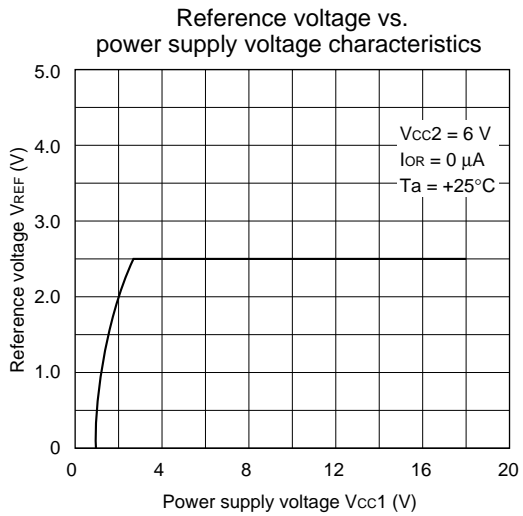
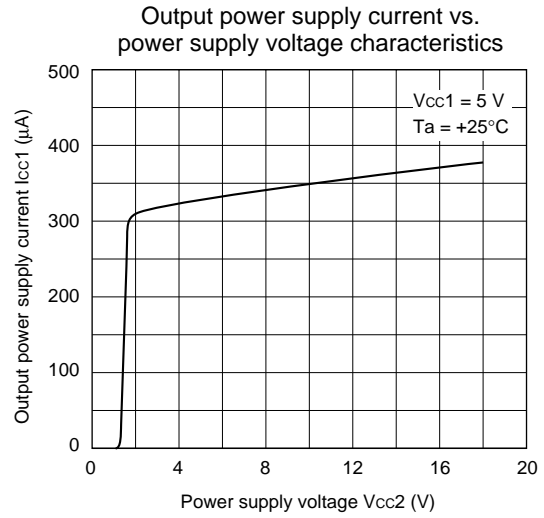
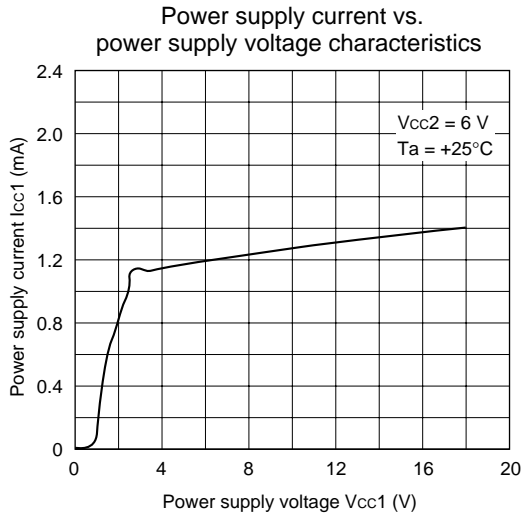

(Continued)

MB3789

Sawtooth waveform period vs. timing capacitance characteristics (With C_T/R_T oscillation)

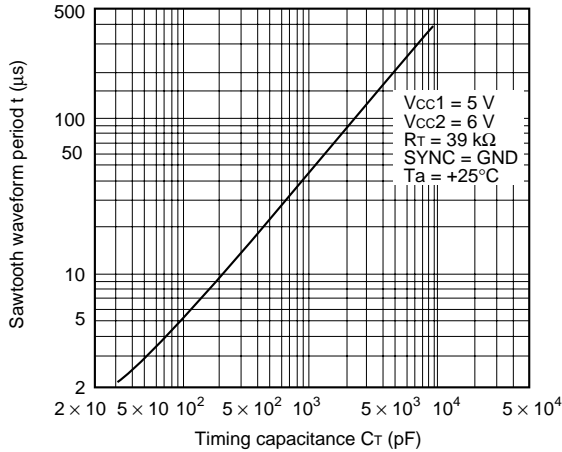

Duty vs. sawtooth wave frequency characteristics (With C_T/R_T oscillation)

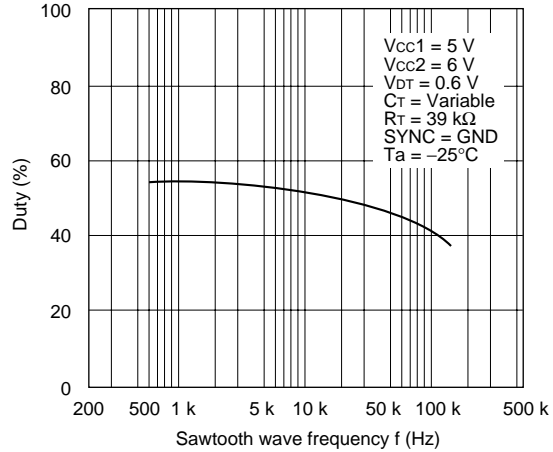

Sawtooth wave frequency vs. ambient temperature characteristics (With C_T/R_T oscillation)

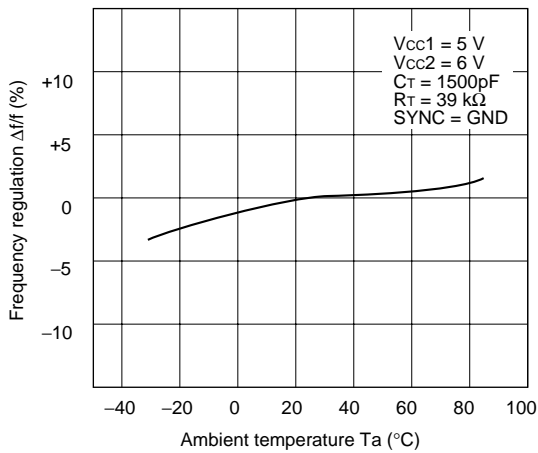

Sawtooth wave frequency vs. ambient temperature characteristics (In external synchronization)

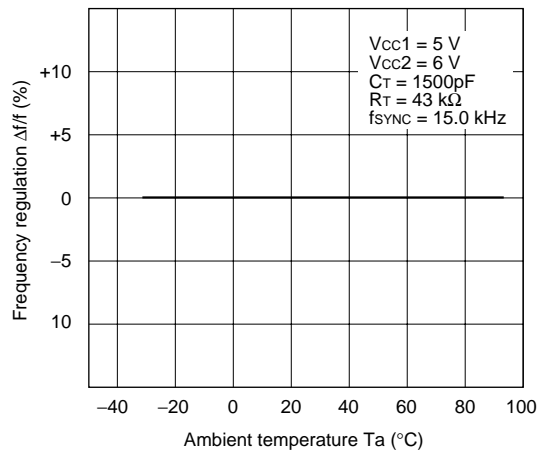

Gain vs. frequency and phase vs. frequency characteristics

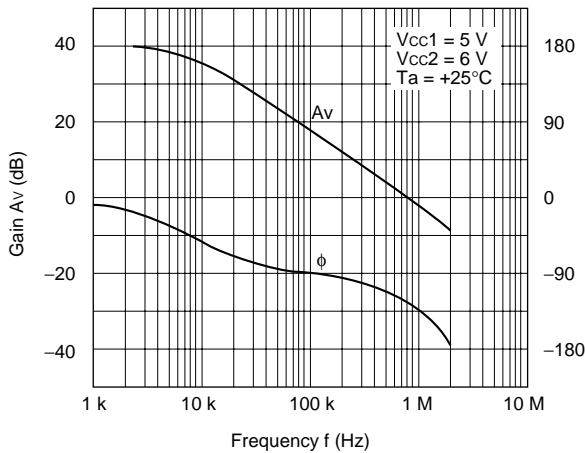

Measurement circuit for gain-frequency characteristics and phase-frequency characteristics

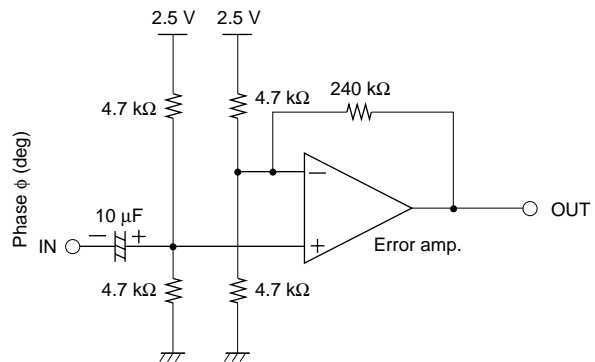

(Continued)

MB3789

(Continued)

Duty vs. DTC pin voltage characteristics

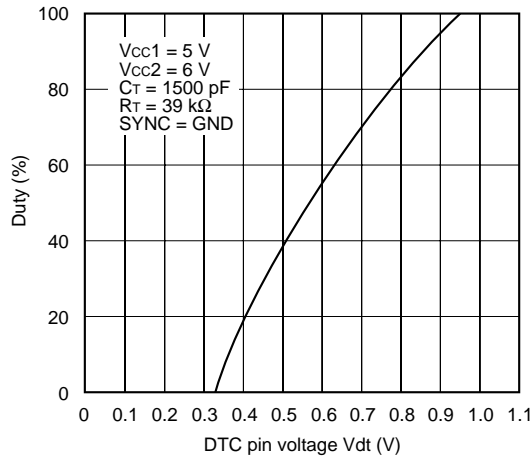

Output pin (OUT) voltage and current waveforms

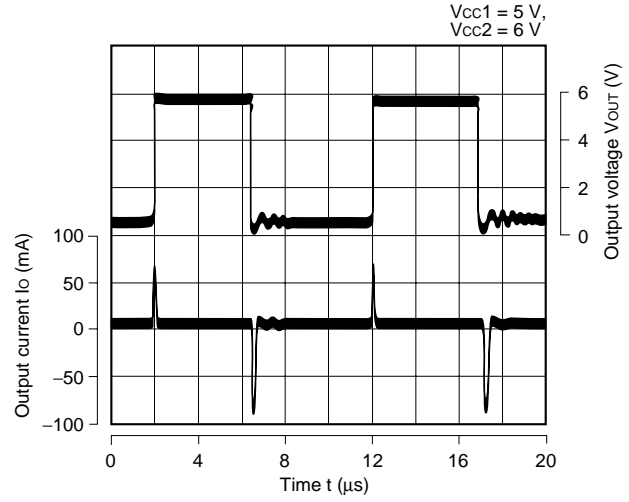

Power consumption vs. ambient temperature characteristics

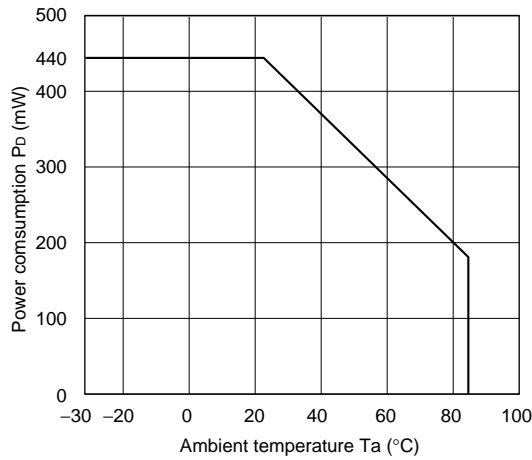

■ SETTING THE OUTPUT VOLTAGE

Set the output voltage by connecting the input pins (+IN, -IN) and output pin (FB) of error amplifiers 1 and 2 as shown in Figures 1 and 2.

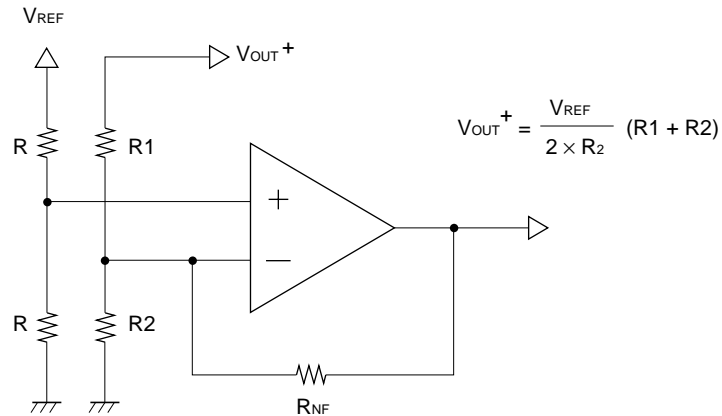

Figure 1 Setting the output voltage (positive output voltage (V_{OUT}))

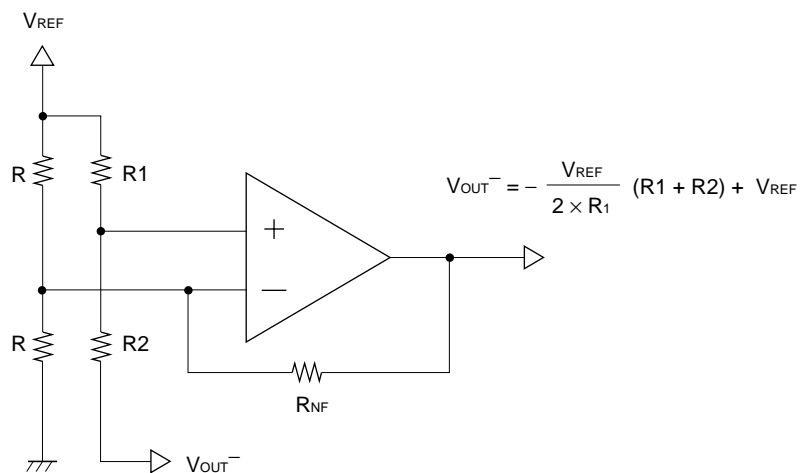

Figure 2 Setting the output voltage (negative output voltage (V_{OUT}))

MB3789

■ CONNECTION FOR OUTPUT CONTROL WITH ONE ERROR AMPLIFIER

The MB3789 can make up a system using only one of the two error amplifiers. In this case, connect the +IN and -IN pins of the unused error amplifier to the V_{REF} and GND pins, respectively, and leave the FB pin open.

When $V_{CC} - 1.8\text{ V} < V_{REF}$, divide the V_{REF} voltage using a resistor and apply the voltage to the +IN pin.

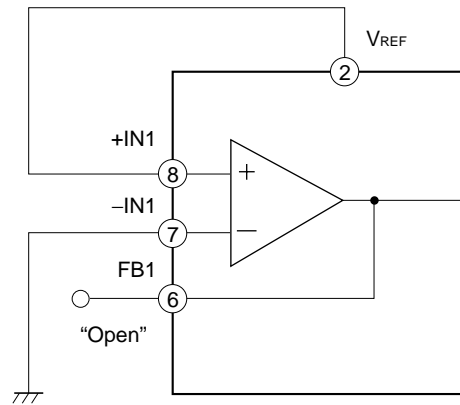

Figure 1 Connection without using error amplifier 1

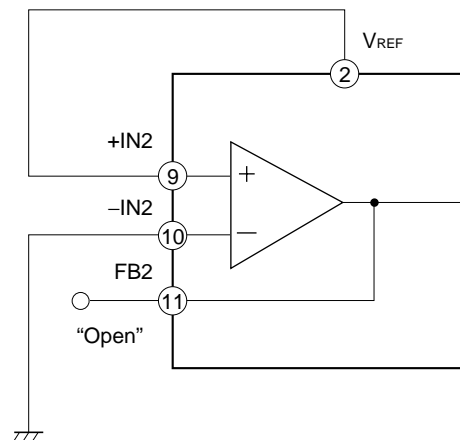

Figure 2 Connection without using error amplifier 2

■ CONNECTING THE SAWTOOTH WAVEFORM OSCILLATOR

1. Connection for internal oscillation

For internal oscillation, connect the frequency setting capacitor (C_T) and resistor (R_T) to the C_T pin (pin 3) and leave the SYNC pin (pin 4) open or connect it to GND.

The oscillation frequency can be set with the C_T and R_T constants.

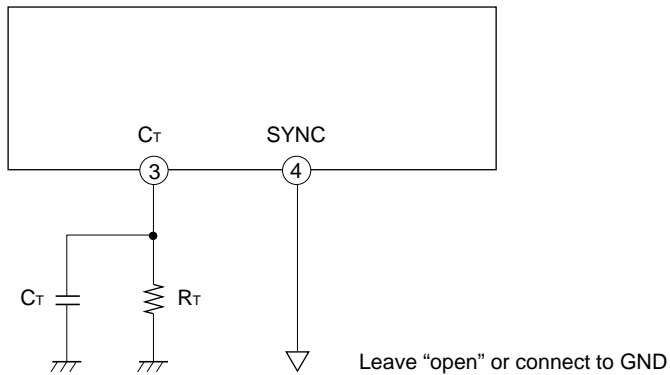

Figure 5 Connection for internal oscillation

2. Connection for external synchronous oscillation

For external synchronous oscillation, connect the frequency setting capacitor (C_T) and resistor (R_T) to the C_T pin (pin 3) and connect the external sync signal to the SYNC pin (pin 4).

In this case, select the C_T and R_T conditions so that the oscillation frequency is 5% to 10% lower than the frequency of the external sync signal excluding the setting error of the oscillation frequency.

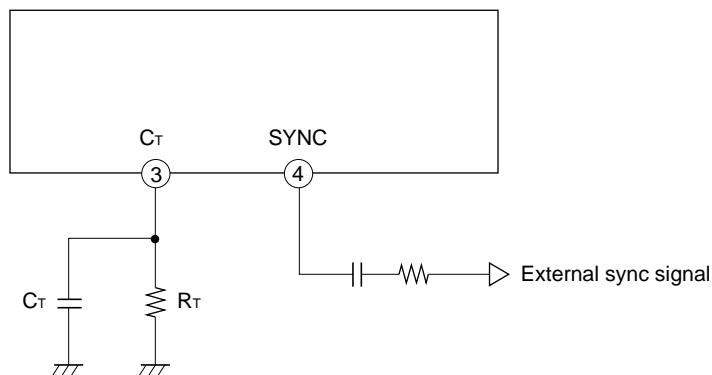

Figure 6 Connection for external synchronous oscillation

MB3789

■ SETTING THE DEAD TIME

When the device is set for step-up inverting output based on the flyback method, the output transistor is fixed to a full-ON state (ON duty = 100%) when the power supply is turned on. To prevent this problem, you may determine the voltage at the DTC pin (pin 12) from the V_{REF} voltage so you can set the output transistor's dead time (maximum ON-duty period) as shown in Figure 7 below.

1. Setting the dead time

When setting the dead time, use resistors as shown in Figure 7 to connect the V_{REF} and DTC pins to GND. When the voltage at the DTC pin (pin 12) is lower than the sawtooth wave output voltage from the oscillator, the output transistor is turned off.

To set the dead time, see "Duty vs. DTC pin voltage" (in "■ STANDARD CHARACTERISTIC CURVES").

$$V_{dt} = \frac{R2}{R1 + R2} \times V_{REF}$$

2. Connection without setting the dead time

If you do not set the dead time, connect the V_{REF} and DTC pins as shown in Figure 8.

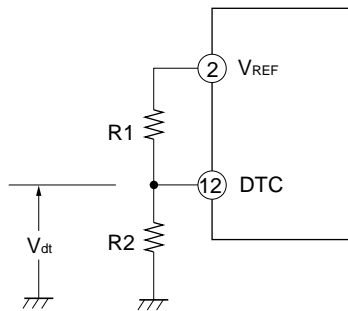

Figure 7 Connection for setting the dead time

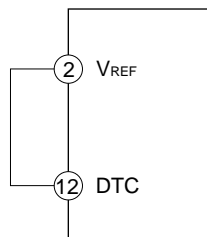
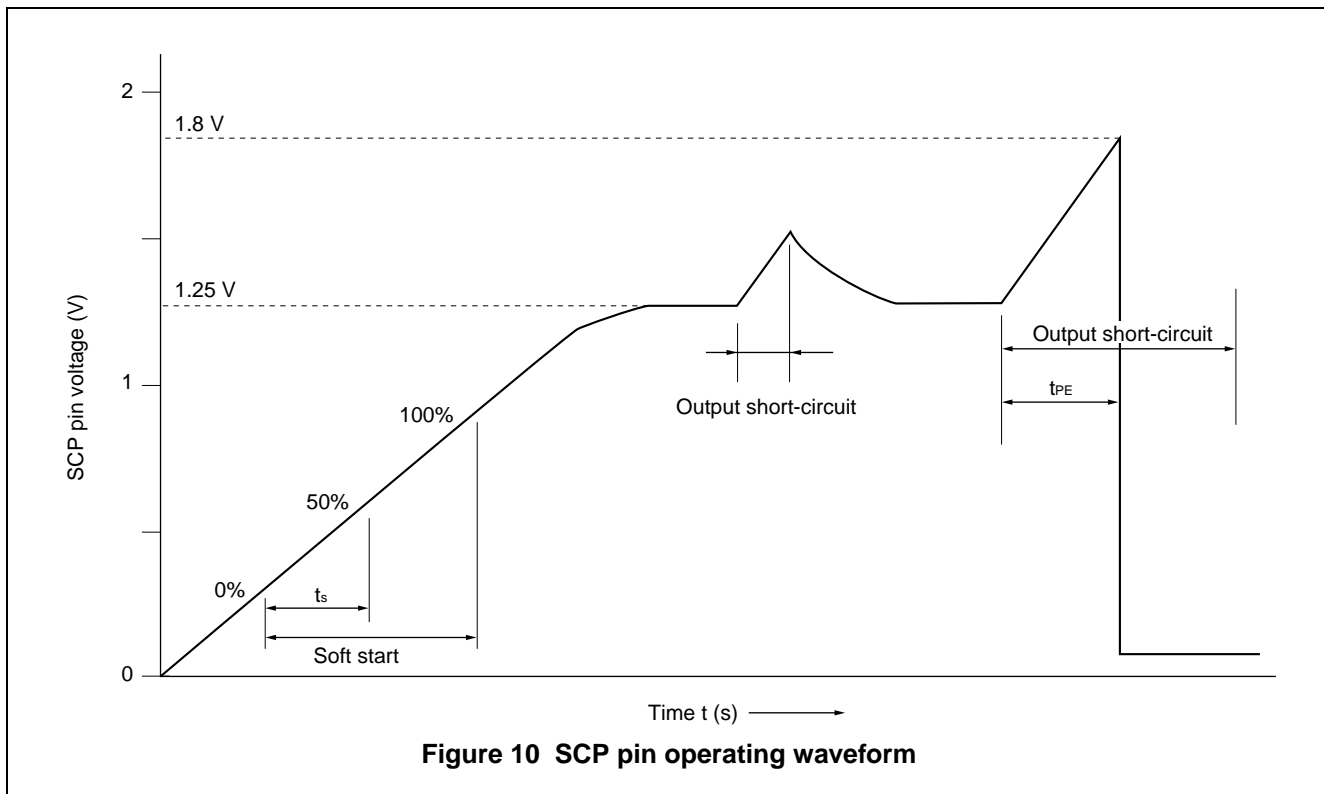
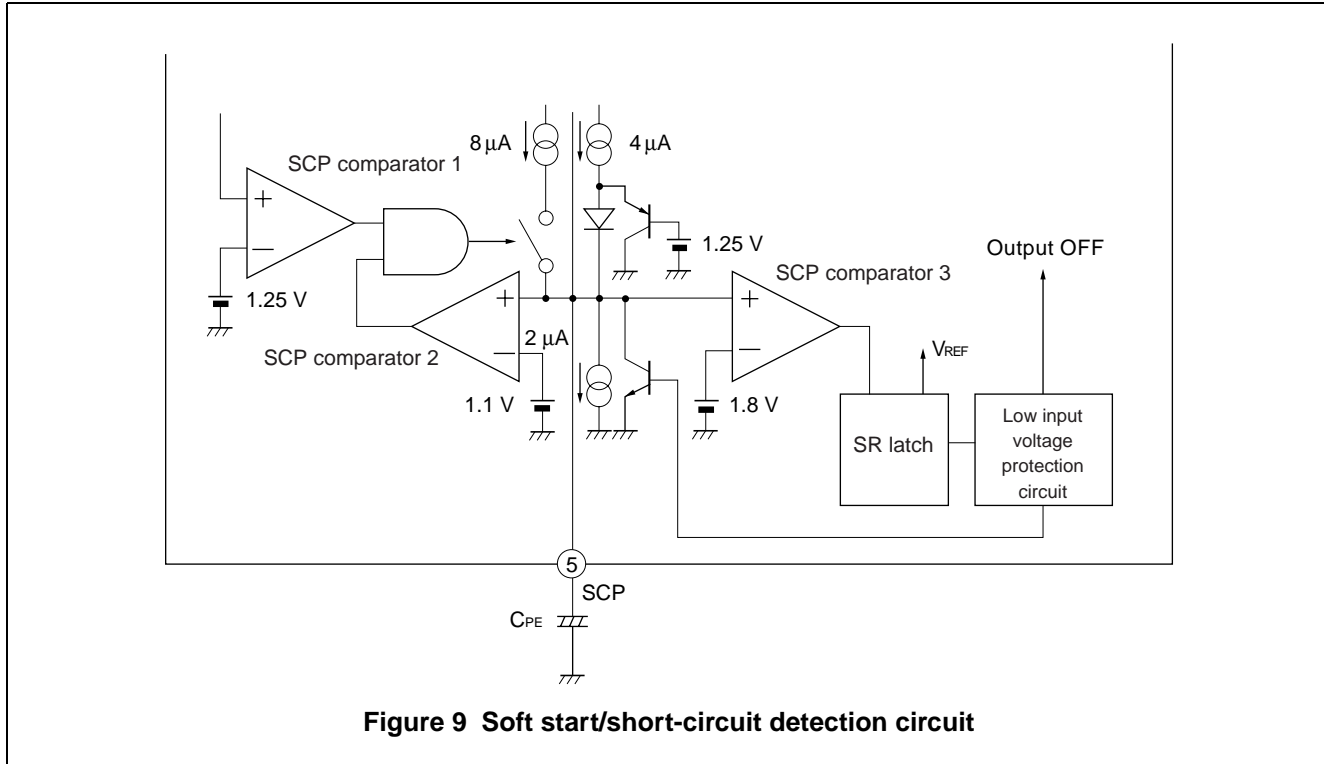

Figure 8 Connection without setting the dead time

■ SETTING THE SOFT START/SHORT-CIRCUIT DETECTION TIME

Connecting capacitor C_{PE} to the SCP pin (pin 5) as shown in Figure 9 enables a soft start and short-circuit protection.



MB3789

1. Soft Start

To prevent surge currents when the IC is turned on, you can set a soft start by connecting capacitor C_{PE} to the SCP pin (pin 5).

- Softstart time(t_s): Time required up to duty cycle $\approx 50\%$ with output on
 $t_s (s) \approx 0.15 \times C_{PE} (\mu F)$

2. Protection from short circuit

SCP comparator 1 always compares the output voltage levels at error amplifiers 1 and 2 with the 1.25 V reference voltage.

When the load conditions for the switching regulator are stable, the outputs from error amplifiers 1 and 2 do not vary and thus short-circuit protection control remains balanced. In this case, the SCP pin (pin 5) is held at the soft start end voltage (about 1.25 V).

If the load conditions change rapidly and the output voltage of error amplifier 1 or 2 reaches 1.25 V, for example, because of a short-circuit of a load, capacitor C_{PE} is charged further. When capacitor C_{PE} is charged up to about 1.8 V, the SR latch is set and the output drive transistor is turned off. At this time, the dead time is set to 100%, capacitor C_{PE} is discharged, and the SCP pin becomes ≈ 50 mV.

- Short-circuit detection time (t_{PE})
 $t_{PE} (s) \approx 0.09 \times C_{PE} (\mu F)$

3. Connection without using short-circuit protection

Add a clamp circuit as shown in Figure 11 so that the clamp voltage (V_{CRP}) falls within the following range when a short-circuit is detected: $1.0 \text{ V} < V_{CRP} < 1.7 \text{ V}$

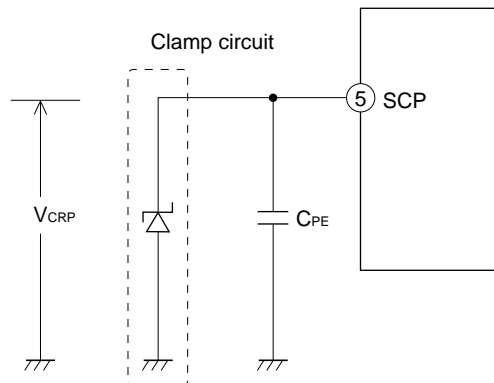

Figure 11 Connection without using short-circuit protection

■ SETTING THE BOOTSTRAP CAPACITOR

When a bootstrap capacitor is connected, it raises the output-ON voltage (at the OUT pin (pin 15)) when the external MOS FET is turned "ON") to the $\approx V_{CC2}$ level. It can therefore drive the MOS FET at a higher threshold voltage (V_{th}).

1. Connecting the bootstrap capacitor

Connect the bootstrap capacitor between the CB pin (pin 13) and OUT pin (pin 15).

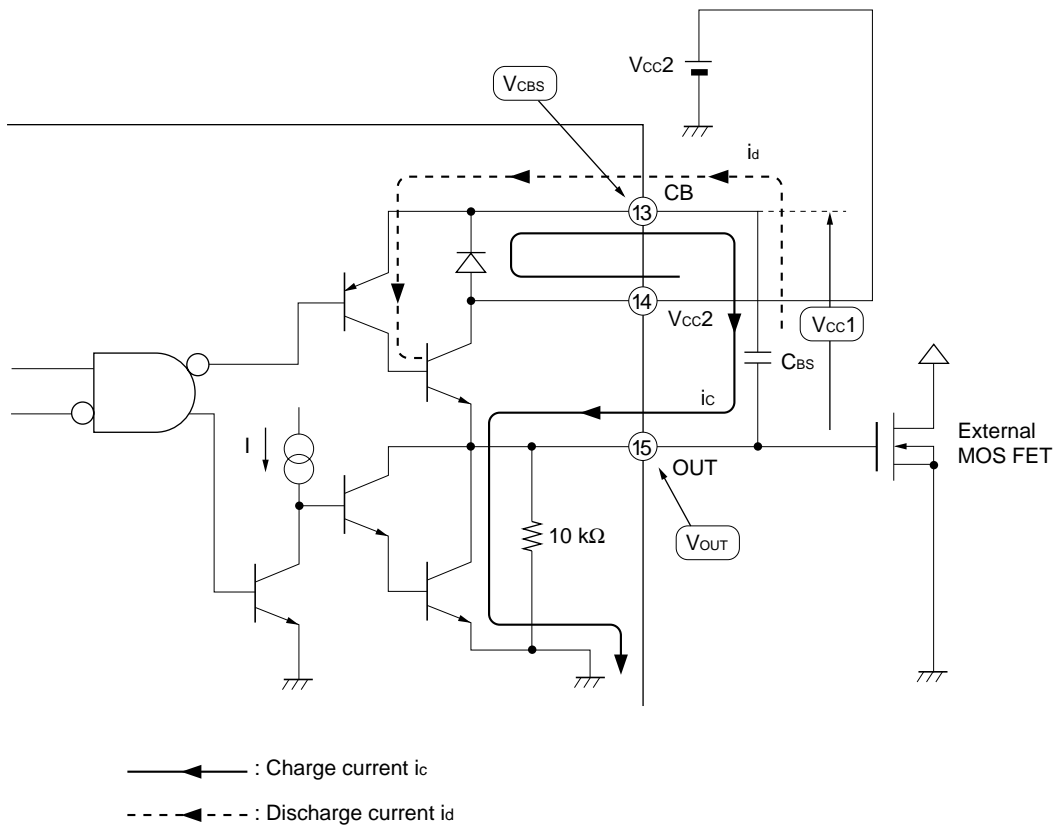

Figure 12 Circuit with a bootstrap capacitor connected and current flow

- Calculation of bootstrap capacitance

$$C_{BS} \geq \frac{500 \times 10^6}{V_{CC2} - 2.6} \times t_{ON} (\text{max}) \text{ [pF]}$$

$t_{ON} (\text{max})$: Maximum ON duty time

MB3789

2. Connection with no bootstrap capacitor

Connect the CB pin (pin 13) and V_{cc2} pin (pin 14) as shown in Figure 13.

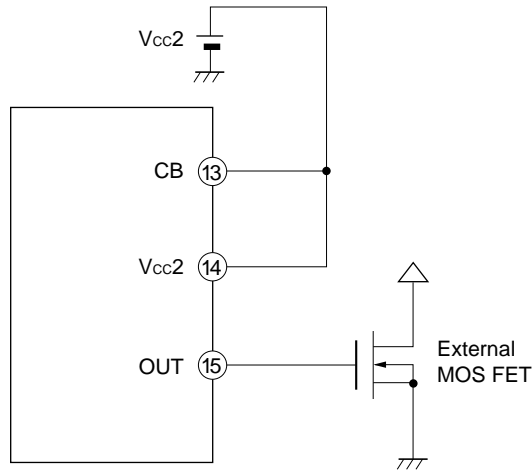

Note: Under a condition of " $V_{cc2} - V_{th} < 1.1 V$ ", bootstrap capacitor C_{BS} should be connected because the external MOS FET cannot be driven sufficiently.

V_{th}: External MOS FET threshold voltage

Figure 13 Connection with no bootstrap capacitor connected

3. Operation of the Bootstrap Capacitor

When voltage V_{OUT} at the OUT pin (pin 15) is "L" level, the voltages (V_{C1}) at both ends of the bootstrap capacitor C_{BS} is charged up to the V_{CC2} voltage level by charge current (i_c).

When V_{OUT} changes from "L" level to "H" level, the CB pin (pin 13) voltage V_{CBS} rises to $\approx 2 \times V_{CC2}$ and V_{OUT} reaches almost the V_{CC2} level.

The charge accumulated at C_{BS} at this time is released by discharge current i_d (output unit supply current). See Figure 12 for circuit operation.

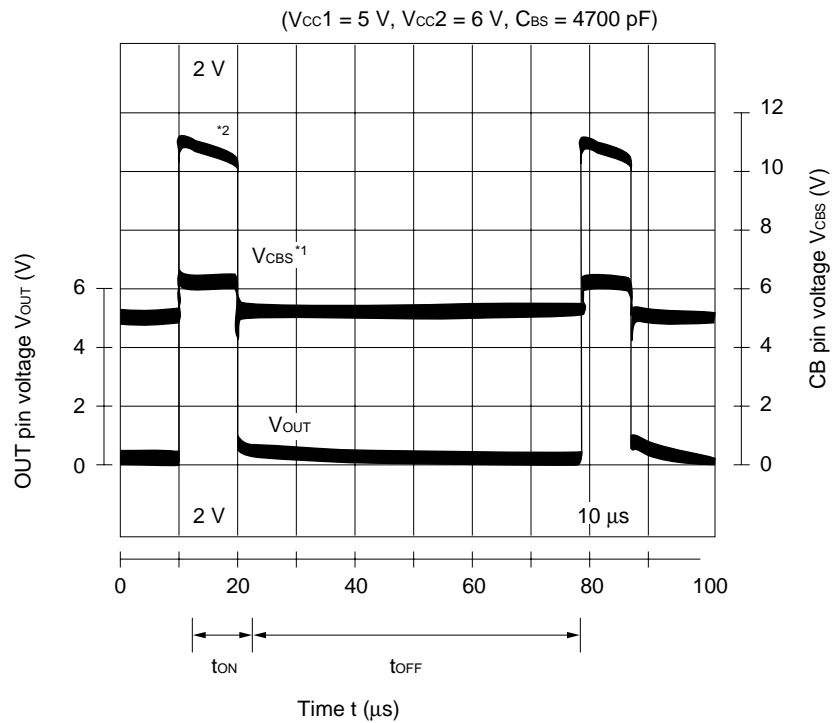

*1: Use the device with a setting of $V_{CBS} \leq 18\text{ V}$.

*2: The slant of V_{CBS} is determined by the value of discharge current i_d (output unit supply current).

Figure 14 Bootstrap operating waveform

MB3789

■ EQUIVALENT SERIES RESISTANCE OF SMOOTHING CAPACITOR AND SYSTEM STABILITY

The equivalent series resistance (ESR) value of a smoothing capacitor for the DC/DC converter largely affects the loop phase characteristic.

Depending on the ESR value, the phase characteristic causes the ideal capacitor in a high-frequency domain advance the loop phase (as shown in Figures 16 and 17) and thus the system is improved in stability. In contrast, using a smoothing capacitor with low ESR lowers system stability. Use meticulous care when a semiconductor electrolytic capacitor with low ESR (such as an OS capacitor) or a tantalum capacitor is used. (The next page gives an example of reduction in phase margin when an OS capacitor is used.)

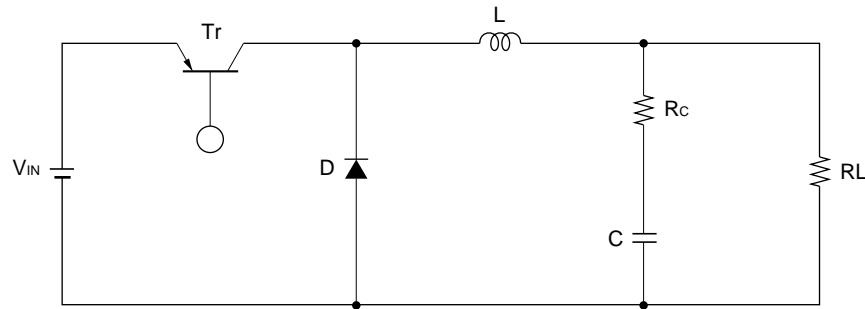

Figure 15 Basic circuit of step-down DC/DC converter

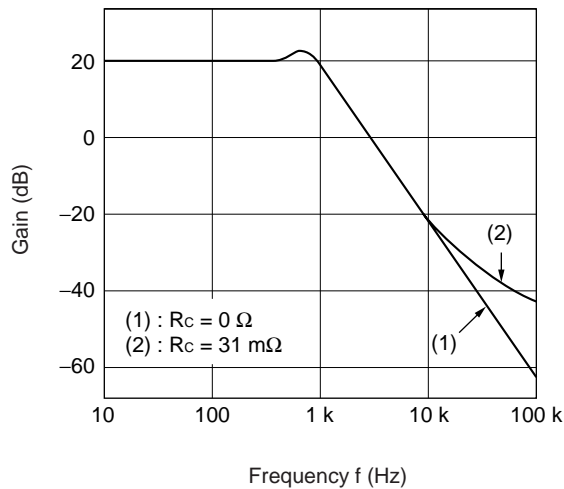

Figure 16 Gain vs. frequency

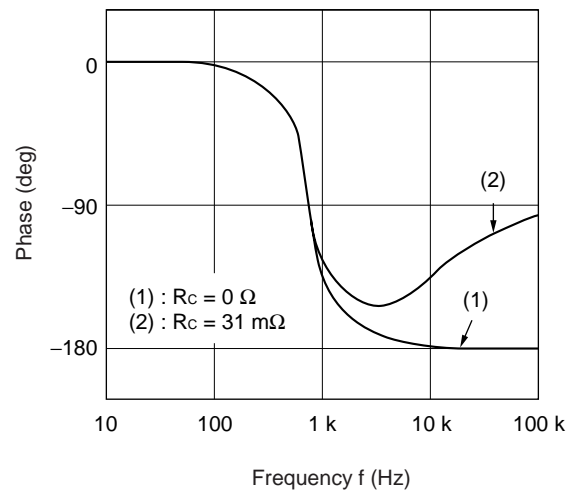
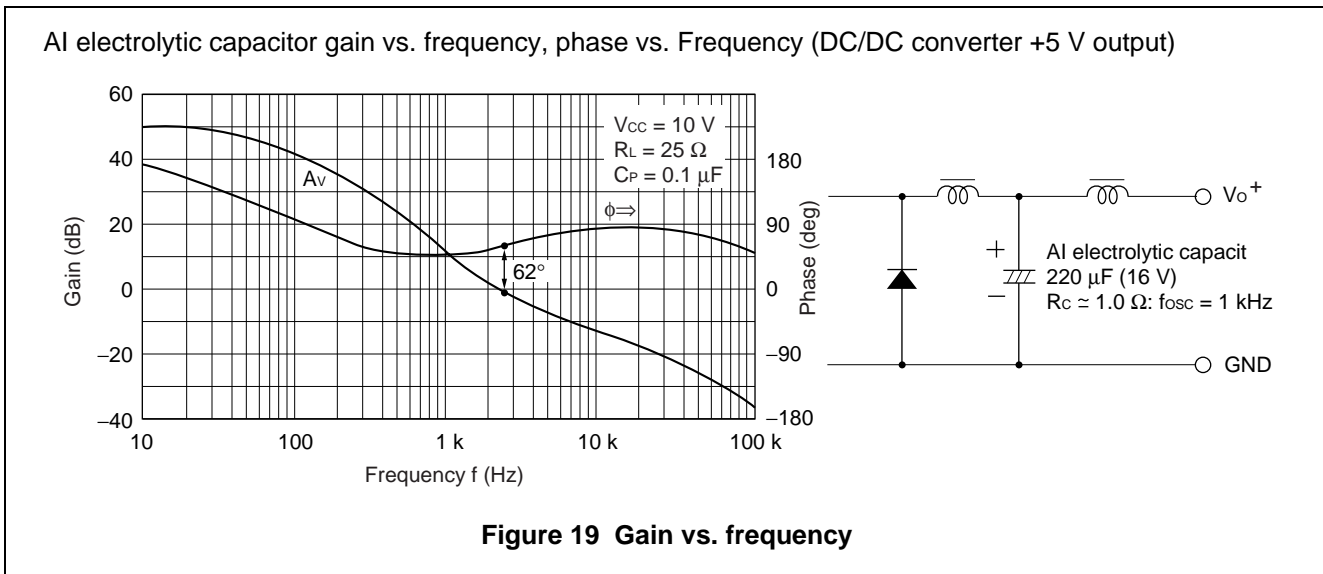
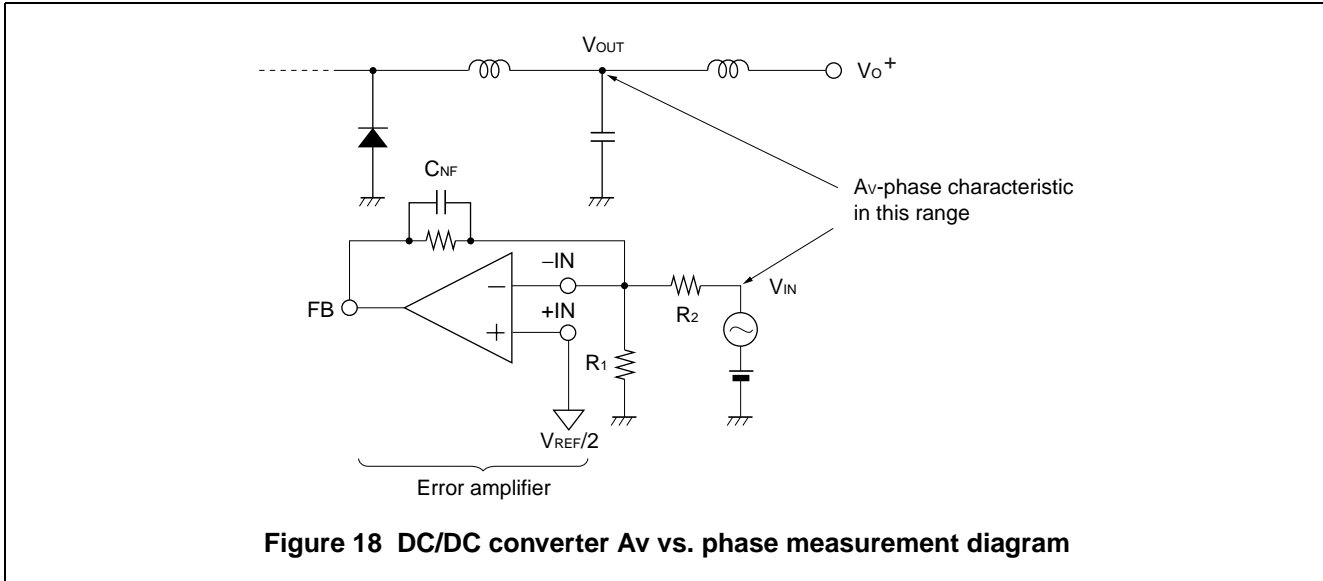

Figure 17 Phase vs. frequency

(Reference data)

Changing the smoothing capacitor from an aluminum electrolytic capacitor ($R_c \approx 1.0 \Omega$) to a low-ESR semiconductor electrolytic capacitor (OS capacitor: $R_c \approx 0.2 \Omega$) halves the phase margin. (See Figures 19 and 20.)



MB3789

OS capacitor gain vs. frequency, phase vs. frequency (DC/DC converter +5 V output)

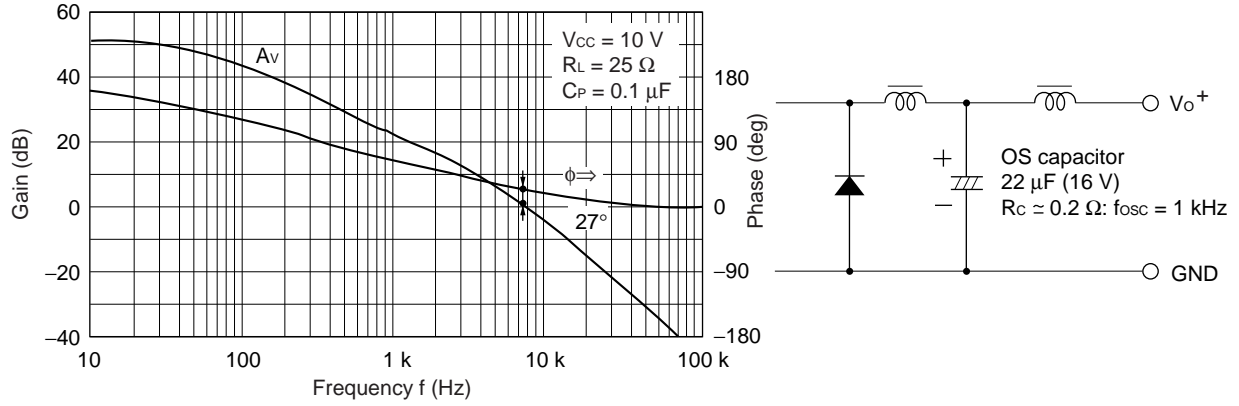
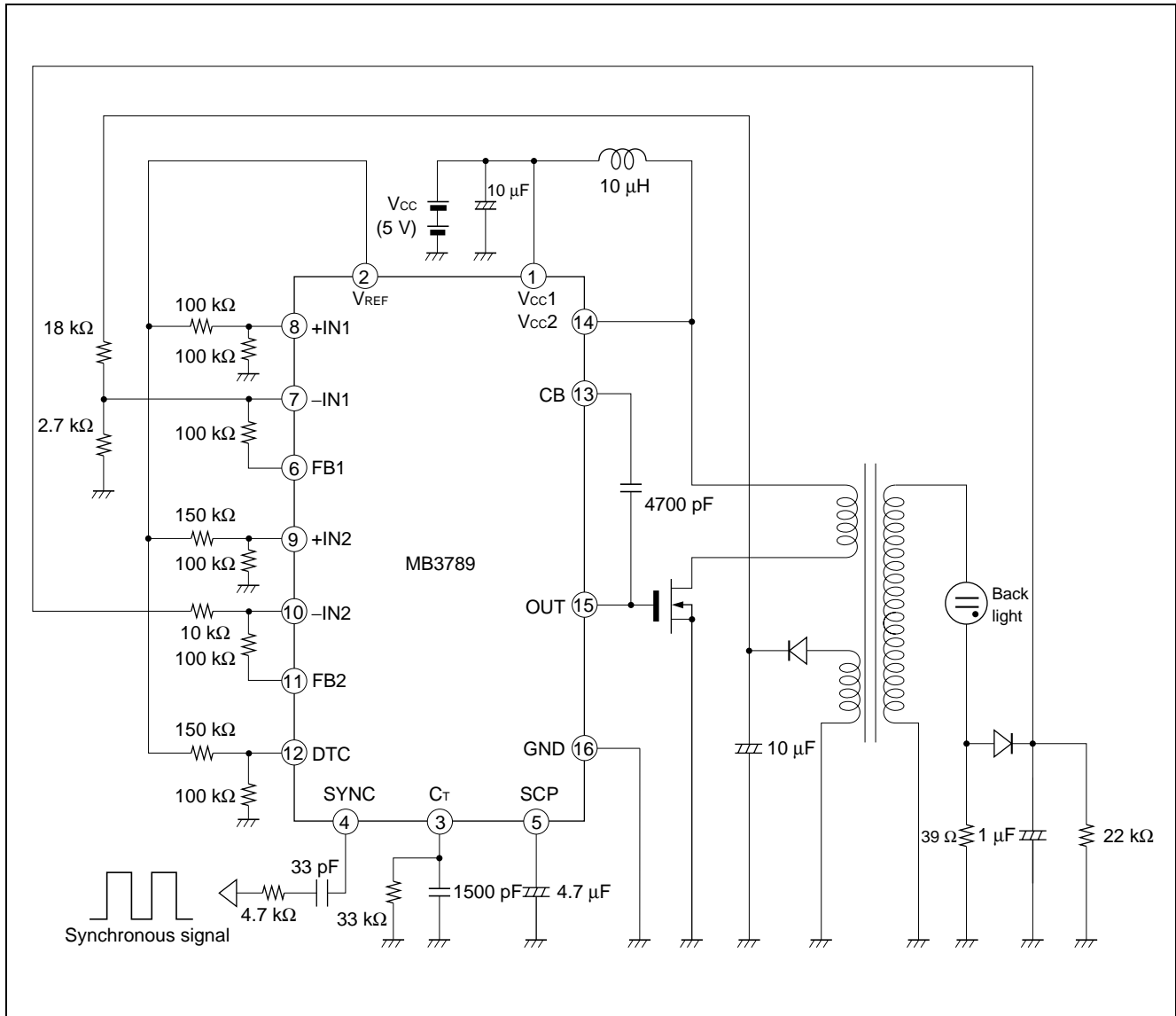

Figure 20 Phase vs. frequency characteristic curves

MB3789

APPLICATION EXAMPLE



MB3789

■ USAGE PRECAUTIONS

1. Do not input voltages greater than the maximum rating.

Inputting voltages greater than the maximum rating may damage the device.

2. Always use the device under recommended operating conditions.

If a voltage greater than the maximum value is input to the device, its electrical characteristics may not be guaranteed. Similarly, inputting a voltage below the minimum value may cause device operation to become unstable.

3. For grounding the printed circuit board, use as wide ground lines as possible to prevent high-frequency noise.

Because the device uses high frequencies, it tends to generate high-frequency noise.

4. Take the following measures for protection against static charge:

- For containing semiconductor devices, use an antistatic or conductive container.
- When storing or transporting device-mounted circuit boards, use a conductive bag or container.
- Ground the workbenches, tools, and measuring equipment to earth.
- Make sure that operators wear wrist straps or other appropriate fittings grounded to earth via a resistance of 250 k to 1 M Ω placed in series between the human body and earth.

■ ORDERING INFORMATION

Part number	Package	Remarks
MB3789PFV	16-pin Plastic SSOP (FPT-16P-M05)	

MB3789

■ PACKAGE DIMENSION

16-pin Plastic SSOP
(FPT-16P-M05)

*: These dimensions do not include resin protrusion.

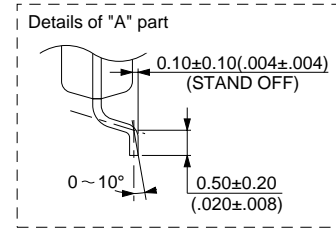
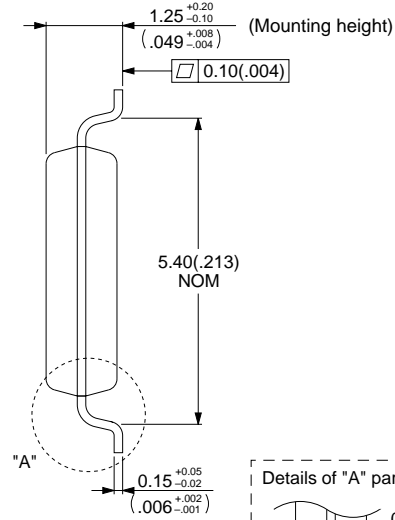
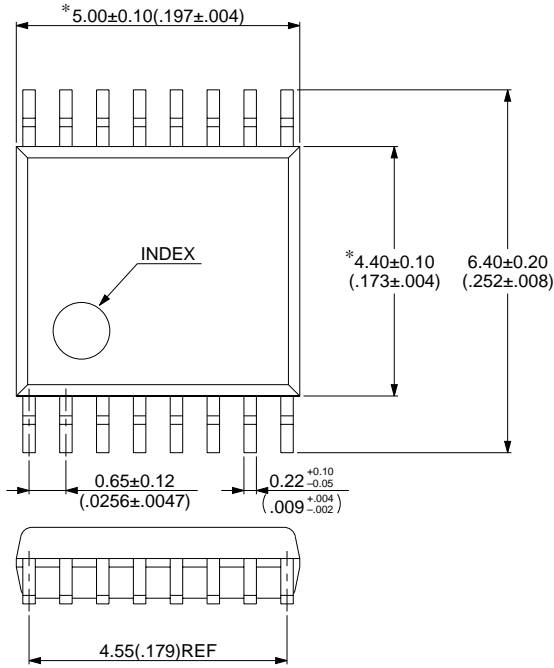

© 1994 FUJITSU LIMITED F16013S-2C-4

Dimensions in mm (inches)

MB3789

FUJITSU LIMITED

For further information please contact:

Japan

FUJITSU LIMITED
Corporate Global Business Support Division
Electronic Devices
KAWASAKI PLANT, 4-1-1, Kamikodanaka
Nakahara-ku, Kawasaki-shi
Kanagawa 211-8588, Japan
Tel: 81(44) 754-3763
Fax: 81(44) 754-3329

<http://www.fujitsu.co.jp/>

North and South America

FUJITSU MICROELECTRONICS, INC.
Semiconductor Division
3545 North First Street
San Jose, CA 95134-1804, USA
Tel: (408) 922-9000
Fax: (408) 922-9179

Customer Response Center
Mon. - Fri.: 7 am - 5 pm (PST)
Tel: (800) 866-8608
Fax: (408) 922-9179

<http://www.fujitsumicro.com/>

Europe

FUJITSU MIKROELEKTRONIK GmbH
Am Siebenstein 6-10
D-63303 Dreieich-Buchsschlag
Germany
Tel: (06103) 690-0
Fax: (06103) 690-122

<http://www.fujitsu-edc.com/>

Asia Pacific

FUJITSU MICROELECTRONICS ASIA PTE LTD
#05-08, 151 Lorong Chuan
New Tech Park
Singapore 556741
Tel: (65) 281-0770
Fax: (65) 281-0220

<http://www.fmap.com.sg/>

F9906

© FUJITSU LIMITED Printed in Japan

All Rights Reserved.

The contents of this document are subject to change without notice. Customers are advised to consult with FUJITSU sales representatives before ordering.

The information and circuit diagrams in this document are presented as examples of semiconductor device applications, and are not intended to be incorporated in devices for actual use. Also, FUJITSU is unable to assume responsibility for infringement of any patent rights or other rights of third parties arising from the use of this information or circuit diagrams.

FUJITSU semiconductor devices are intended for use in standard applications (computers, office automation and other office equipment, industrial, communications, and measurement equipment, personal or household devices, etc.).

CAUTION:

Customers considering the use of our products in special applications where failure or abnormal operation may directly affect human lives or cause physical injury or property damage, or where extremely high levels of reliability are demanded (such as aerospace systems, atomic energy controls, sea floor repeaters, vehicle operating controls, medical devices for life support, etc.) are requested to consult with FUJITSU sales representatives before such use. The company will not be responsible for damages arising from such use without prior approval.

Any semiconductor devices have an inherent chance of failure. You must protect against injury, damage or loss from such failures by incorporating safety design measures into your facility and equipment such as redundancy, fire protection, and prevention of over-current levels and other abnormal operating conditions.

If any products described in this document represent goods or technologies subject to certain restrictions on export under the Foreign Exchange and Foreign Trade Law of Japan, the prior authorization by Japanese government will be required for export of those products from Japan.