

# 600mA, 500kHz Micropower Synchronous Boost Converter with Output Disconnect

## FEATURES

- Up to 96% Efficiency
- True Output Load Disconnect
- Inrush Current Limiting and Internal Soft-Start
- Low Voltage Start-Up: 0.85V
- Automatic Burst Mode<sup>®</sup> Operation with  $I_Q \sim 20\mu\text{A}$
- Internal Synchronous Rectifier
- Current Mode Control with Internal Compensation
- Short-Circuit Protection
- 500kHz Fixed Frequency Switching
- Input Range: 0.5V to 4.4V
- Output Range: 2.5V to 4.3V (Up to 5V with Schottky)
- Shutdown Current:  $< 1\mu\text{A}$
- Antiringing Control minimizes EMI
- Tiny External Components
- Low Profile (1mm) SOT-23 Package

## APPLICATIONS

- MP3 Players
- Digital Cameras
- LCD Bias Supplies
- Handheld Instruments
- Wireless Handsets
- GPS Receivers

## DESCRIPTION

The LTC<sup>®</sup>3429 is a high efficiency synchronous, fixed frequency, step-up DC/DC converter with true output load disconnect, inrush current limiting and soft-start in a low profile 6-lead ThinSOT<sup>™</sup> package. This device is capable of supplying 100mA from a single AA cell input or 250mA from a 2-cell AA with a 3.3V output.

A switching frequency of 500kHz minimizes overall solution footprint by allowing the use of tiny, low profile inductors and ceramic capacitors. Current mode PWM control with internal compensation reduces external parts count thereby saving critical board real estate. The LTC3429 shifts automatically to power saving Burst Mode operation at light loads. Antiringing control circuitry reduces EMI concerns by damping the inductor in discontinuous mode.

The device also features low shutdown current of under  $1\mu\text{A}$ . The true output disconnect feature allows the output to be completely discharged in shutdown. It also limits the inrush of current during start-up, minimizing surge currents seen by the input supply.

LT, LTC and LT are registered trademarks of Linear Technology Corporation. Burst Mode is a registered trademark of Linear Technology Corporation. ThinSOT is a trademark of Linear Technology Corporation.

## TYPICAL APPLICATION

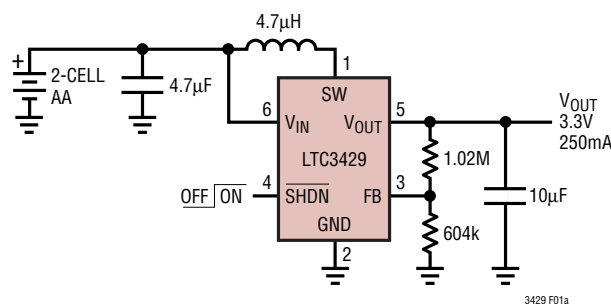
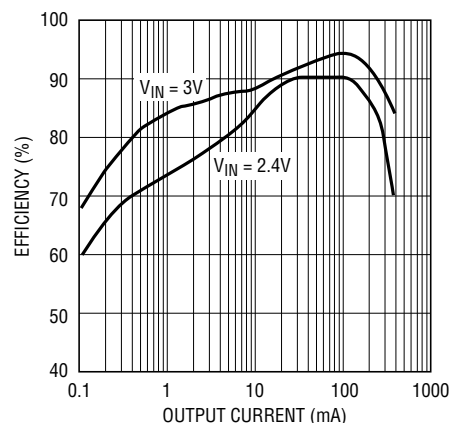

Figure 1. 2-Cell to 3.3V Synchronous Boost Converter

2-Cell to 3.3V Efficiency



3429 F01b

## ABSOLUTE MAXIMUM RATINGS

(Note 1)

$V_{IN}$ Voltage .....	-0.3V to 4.4V
SW Voltage .....	-0.3V to 6V
SHDN, FB Voltage .....	-0.3V to 6V
$V_{OUT}$ .....	-0.3V to 6V
Operating Temperature Range (Note 2) ..	-40°C to 85°C
Storage Temperature Range .....	-65°C to 125°C
Lead Temperature (Soldering, 10 sec).....	300°C

## PACKAGE/ORDER INFORMATION

	ORDER PART NUMBER
	LTC3429ES6
	S6 PART MARKING
	LTH5

Consult LTC Marketing for parts specified with wider operating temperature ranges.

## ELECTRICAL CHARACTERISTICS

The ● denotes the specifications which apply over the full operating temperature range, otherwise specifications are at  $T_A = 25^\circ\text{C}$ .  $V_{IN} = 1.2\text{V}$ ,  $V_{OUT} = 3.3\text{V}$ , unless otherwise specified.

PARAMETER	CONDITIONS	MIN	TYP	MAX	UNITS
Minimum Start-Up Voltage	$I_{LOAD} = 1\text{mA}$ , $V_{OUT} = 0\text{V}$		0.85	1	V
Minimum Operating Voltage	$\overline{\text{SHDN}} = V_{IN}$ (Note 3)		0.5	0.65	V
Output Voltage Adjust Range	(Note 5)	2.5		5	V
Feedback Voltage		● 1.192	1.230	1.268	V
Feedback Input Current	$V_{FB} = 1.25\text{V}$		1	50	nA
Quiescent Current (Burst Mode Operation)	$V_{FB} = 1.4\text{V}$ (Note 4)		20	30	$\mu\text{A}$
Quiescent Current (Shutdown)	$\overline{\text{SHDN}} = 0\text{V}$ , Not Including Switch Leakage, $V_{OUT} = 0\text{V}$		0.01	1	$\mu\text{A}$
Quiescent Current (Active)	Measured On $V_{OUT}$ , Nonswitching		380	550	$\mu\text{A}$
NMOS Switch Leakage	$V_{SW} = 5\text{V}$		0.1	5	$\mu\text{A}$
PMOS Switch Leakage	$V_{SW} = 5\text{V}$ , $V_{OUT} = 0\text{V}$		0.1	5	$\mu\text{A}$
NMOS Switch On Resistance			0.35		$\Omega$
PMOS Switch On Resistance			0.45		$\Omega$
NMOS Current Limit		600	850		mA
Burst Mode Operation Current Threshold	$L = 4.7\mu\text{H}$		1.25		mA
Current Limit Delay to Output			40		ns
Max Duty Cycle	$V_{FB} = 1.15\text{V}$	● 80	90		%
Switching Frequency		● 380	500	620	kHz
$\overline{\text{SHDN}}$ Input High		1			V
$\overline{\text{SHDN}}$ Input Low				0.35	V
$\overline{\text{SHDN}}$ Input Current	$\overline{\text{SHDN}} = 5.5\text{V}$		0.01	1	$\mu\text{A}$
Soft-Start Time			2		ms

**Note 1:** Absolute Maximum Ratings are those values beyond which the life of a device may be impaired.

**Note 2:** The LTC3429E is guaranteed to meet performance specifications from 0°C to 70°C. Specifications over the -40°C to 85°C operating temperature range are assured by design, characterization and correlation with statistical process controls.

**Note 3:** Minimum  $V_{IN}$  operation after start-up is only limited by the battery's ability to provide the necessary power as it enters a deeply discharged state.

**Note 4:** Burst Mode operation  $I_Q$  is measured at  $V_{OUT}$ . Multiply this value by  $V_{OUT}/V_{IN}$  to get the equivalent input (battery) current.

**Note 5:** For applications where  $V_{OUT} > 4.3\text{V}$ , an external Schottky diode is required. See the Applications Information.

**TYPICAL PERFORMANCE CHARACTERISTICS** ( $T_A = 25^\circ\text{C}$  unless otherwise specified)

**Single Cell to 3.3V Efficiency**

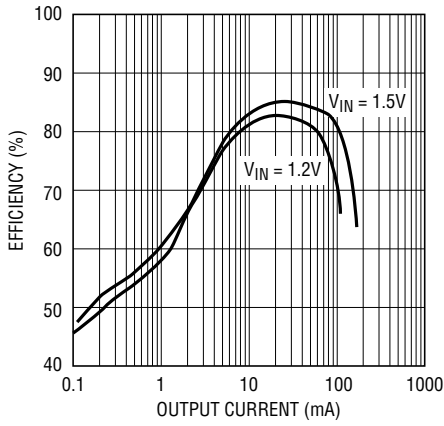

**2-Cell to 3.3V Efficiency**

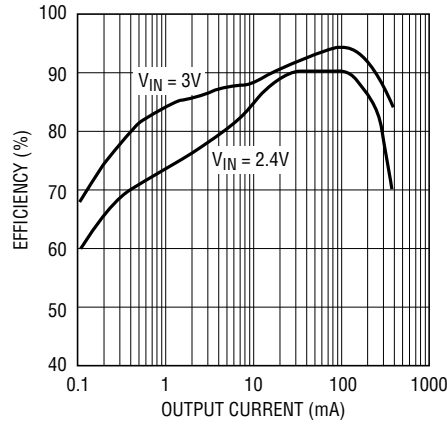

**2-Cell to 5V Efficiency**

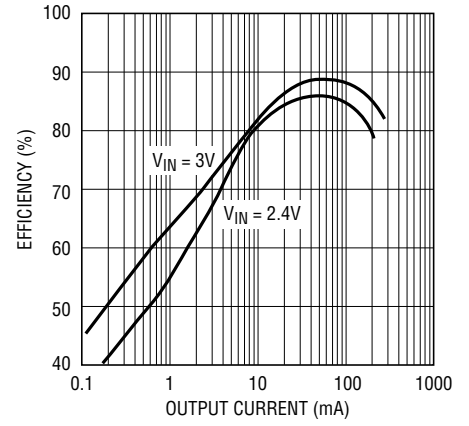

**Li-Ion to 5V Efficiency**

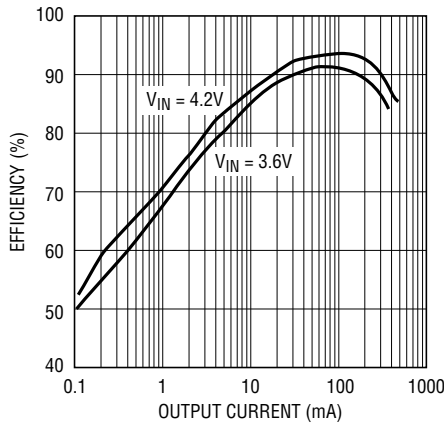

**Efficiency vs Input Voltage**

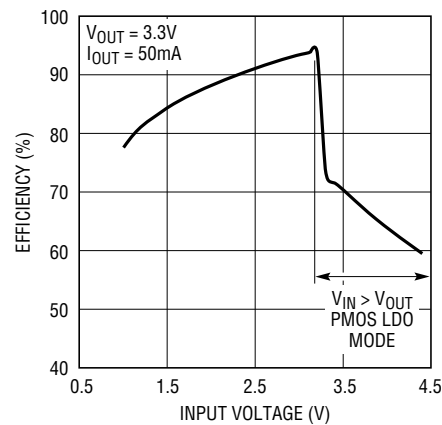

**Burst Mode Output Current Threshold vs Input Voltage**

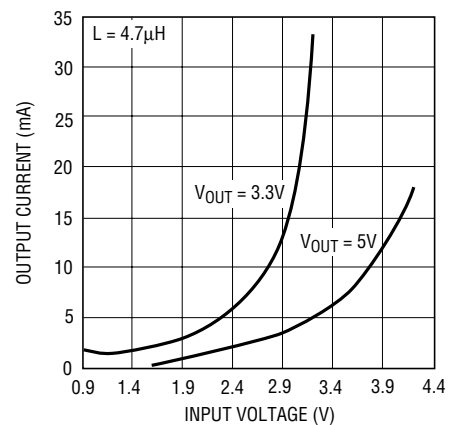

**No Load Input Current vs Input Voltage**

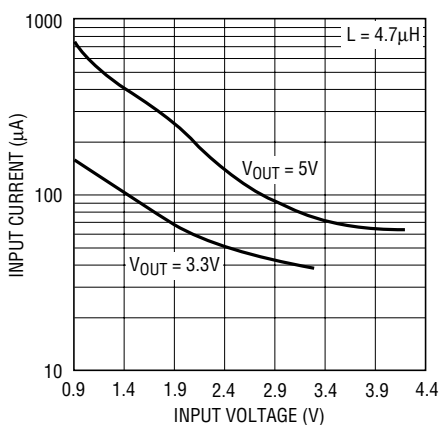

**Maximum Load Current Capability at Output 4% Below Regulation Point**

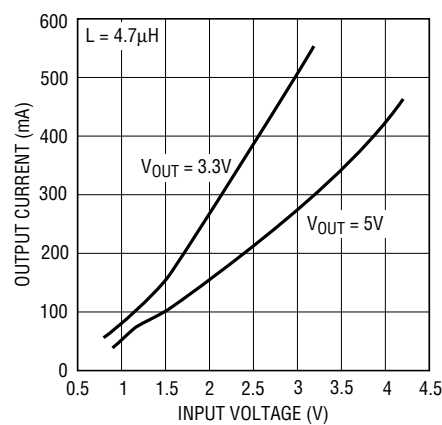

**Minimum Start-Up Input Voltage vs Load Current**

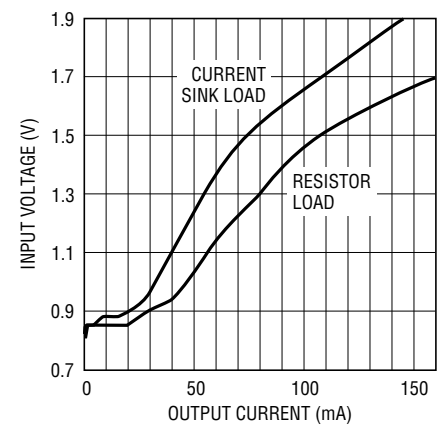

## TYPICAL PERFORMANCE CHARACTERISTICS ( $T_A = 25^\circ\text{C}$ unless otherwise specified)

### Output Voltage vs Temperature

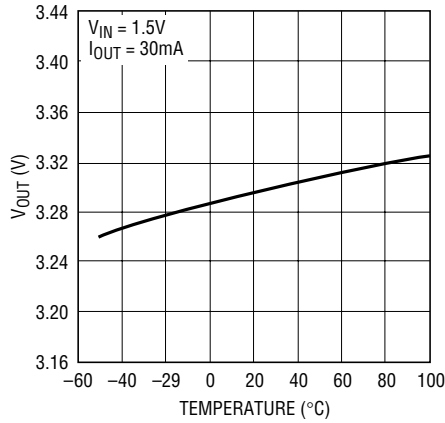

3429 G10

### Normalized Oscillator Frequency vs Temperature

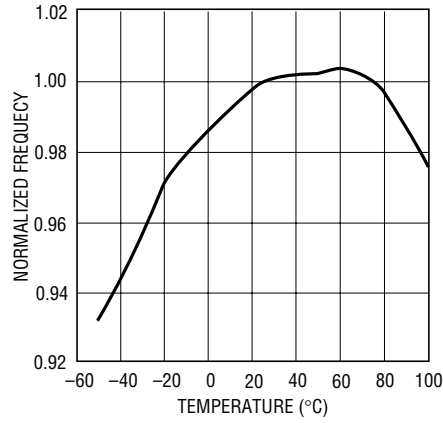

3429 G11

### Burst Mode Quiescent Current vs Temperature

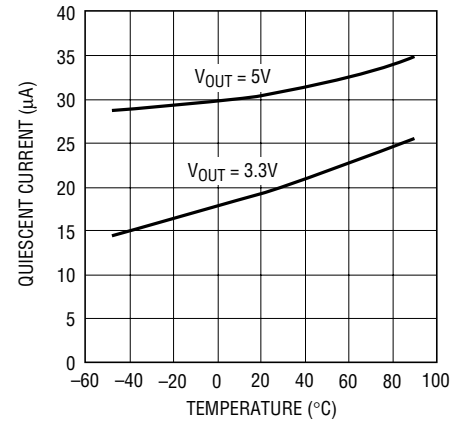

3429 G12

### SW Pin Fixed Frequency Continuous Mode Operation

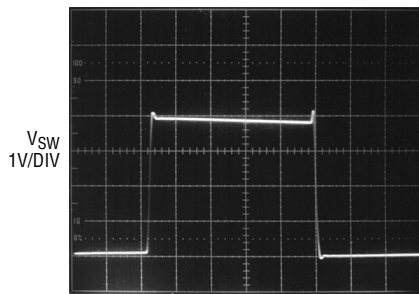

3429 G13

$V_{IN} = 1.5\text{V}$   
 $V_{OUT} = 3.3\text{V}$   
 $I_{OUT} = 50\text{mA}$   
 $L = 10\mu\text{H}$   
 $C_{OUT} = 10\mu\text{F}$   
 $C_{PL} = 150\text{pF}$

### SW Pin Discontinuous Mode Antiringing Operation

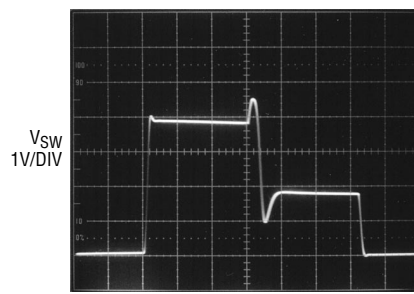

3429 G14

$V_{IN} = 1.5\text{V}$   
 $V_{OUT} = 3.3\text{V}$   
 $I_{OUT} = 20\text{mA}$   
 $L = 10\mu\text{H}$   
 $C_{OUT} = 10\mu\text{F}$   
 $C_{PL} = 150\text{pF}$

### Fixed Frequency and Burst Mode Operation

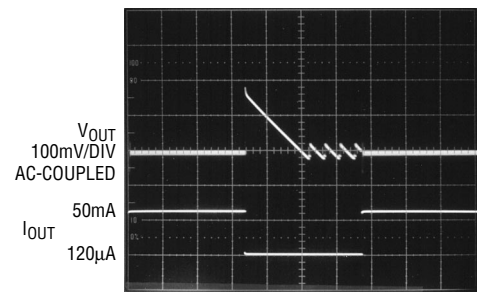

3429 G15

$V_{IN} = 1.5\text{V}$   
 $V_{OUT} = 3.3\text{V}$   
 $I_{OUT} = 120\mu\text{A TO } 50\text{mA STEP}$   
 $L = 10\mu\text{H}$   
 $C_{OUT} = 10\mu\text{F}$   
 $C_{PL} = 150\text{pF}$

### Output Voltage Transient Response

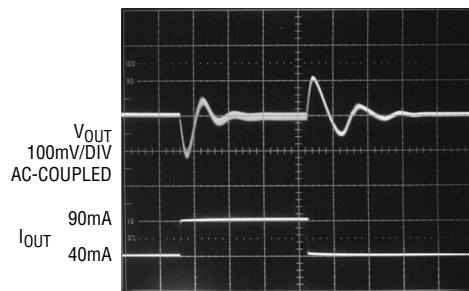

3429 G16

$V_{IN} = 1.5\text{V}$   
 $V_{OUT} = 3.3\text{V}$   
 $I_{OUT} = 40\text{mA TO } 90\text{mA STEP}$   
 $L = 10\mu\text{H}$   
 $C_{OUT} = 10\mu\text{F}$   
 $C_{PL} = 150\text{pF}$

### Inrush Current Control and Soft-Start

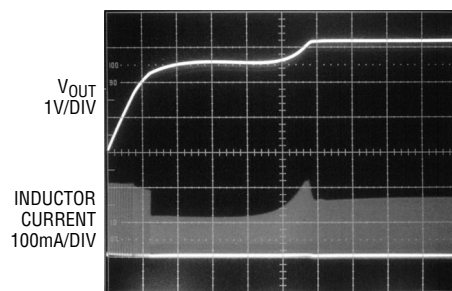

3429 G17

$V_{IN} = 1.5\text{V}$   
 $V_{OUT} = 3.3\text{V}$   
 $I_{OUT} = 10\text{mA}$   
 $L = 4.7\mu\text{H}$   
 $C_{OUT} = 10\mu\text{F}$   
 $C_{PL} = 100\text{pF}$

### Inrush Current Control and Soft-Start

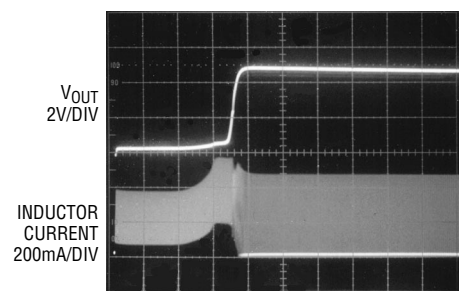

3429 G18

$V_{IN} = 2.5\text{V}$   
 $V_{OUT} = 5\text{V}$   
 $I_{OUT} = 50\text{mA}$   
 $L = 4.7\mu\text{H}$   
 $C_{OUT} = 10\mu\text{F}$   
 $C_{PL} = 100\text{pF}$

## PIN FUNCTIONS

**SW (Pin 1):** Switch Pin. Connect inductor between SW and  $V_{IN}$ . Keep these PCB trace lengths as short and wide as possible to reduce EMI and voltage overshoot. If the inductor current falls to zero, or  $\overline{\text{SHDN}}$  is low, an internal 150 $\Omega$  antiringing switch is connected from SW to  $V_{IN}$  to minimize EMI.

**GND (Pin 2):** Signal and Power Ground. Provide a short direct PCB path between GND and the (–) side of the output capacitor(s).

**FB (Pin 3):** Feedback Input to the  $g_m$  Error Amplifier. Connect resistor divider tap to this pin. The output voltage can be adjusted from 2.5V to 5V by:

$$V_{OUT} = 1.23V \cdot [1 + (R1/R2)]$$

**$\overline{\text{SHDN}}$  (Pin 4):** Logic Controlled Shutdown Input.

$\overline{\text{SHDN}}$  = High: Normal free running operation, 500kHz typical operating frequency.

$\overline{\text{SHDN}}$  = Low: Shutdown, quiescent current <1 $\mu$ A. Output capacitor can be completely discharged through the load or feedback resistors. A 150 $\Omega$  resistor is internally connected between SW and  $V_{IN}$ .

**$V_{OUT}$  (Pin 5):** Output Voltage Sense Input and Drain of the Internal Synchronous Rectifier MOSFET. Bias is derived from  $V_{OUT}$ . PCB trace length from  $V_{OUT}$  to the output filter capacitor(s) should be as short and wide as possible.  $V_{OUT}$  is completely disconnected from  $V_{IN}$  when  $\overline{\text{SHDN}}$  is low due to the output disconnect feature.

**$V_{IN}$  (Pin 6):** Battery Input Voltage. The device gets its start-up bias from  $V_{IN}$ . Once  $V_{OUT}$  exceeds  $V_{IN}$ , bias comes from  $V_{OUT}$ . Thus, once started, operation is completely independent from  $V_{IN}$ . Operation is only limited by the output power level and the battery's internal series resistance.

## BLOCK DIAGRAM

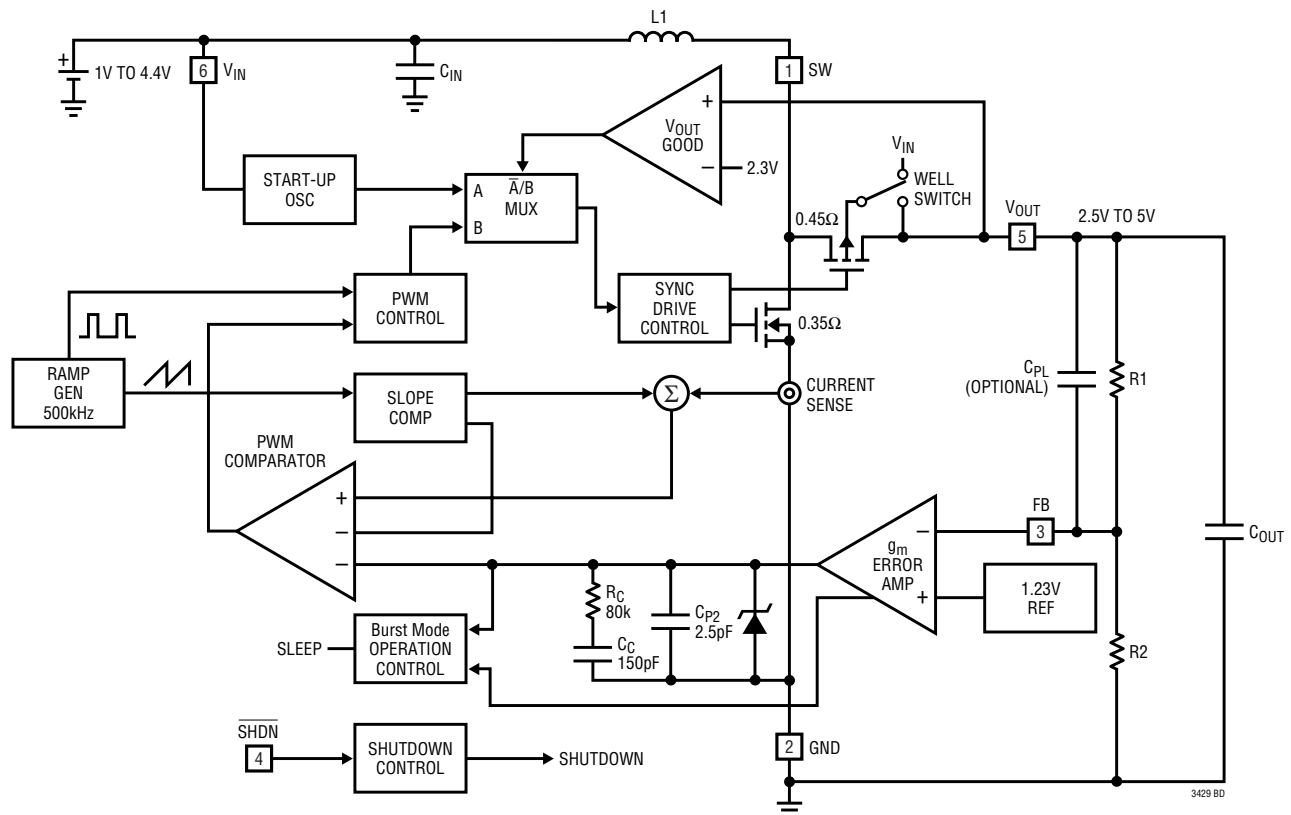

3429f

## OPERATION

The LTC3429 is a 500kHz, synchronous boost converter housed in a 6-lead SOT-23 package. Able to operate from an input voltage below 1V, the device features fixed frequency, current mode PWM control for exceptional line and load regulation. Low  $R_{DS(ON)}$  internal MOSFET switches enable the device to maintain high efficiency over a wide range of load current. Detailed descriptions of the different operating modes follow. Operation can be best understood by referring to the Block Diagram.

### LOW VOLTAGE START-UP

The LTC3429 includes an independent start-up oscillator designed to start up at input voltages of 0.85V typically. The frequency and duty cycle of the start-up oscillator are internally set to 150kHz and 67% respectively. In this mode, the IC operates completely open-loop and the current limit is also set internally to 850mA. Once the output voltage exceeds 2.3V, the start-up circuitry is disabled and normal close-loop PWM operation is initiated. In normal mode, the LTC3429 powers itself from  $V_{OUT}$  instead of  $V_{IN}$ . This allows the battery voltage to drop to as low as 0.5V without affecting the circuit operation. The only limiting factor in the application becomes the ability of the battery to supply sufficient energy to the output. Soft-start and inrush current limiting are provided during start-up as well as normal mode operation.

### Soft-Start

The LTC3429 provides soft-start by charging an internal capacitor with a very weak current source. The voltage on this capacitor, in turn, slowly ramps the peak inductor current from zero to a maximum value of 850mA. The soft-start time is typically 2ms, the time it takes to charge the capacitor from zero to 1.35V. However, this time varies greatly with load current, output voltage and input voltage (see Typical Performance Characteristics, Inrush Current Control and Soft-Start). The soft-start capacitor is discharged completely in the event of a commanded shut-down or a thermal shutdown. It is discharged only partially in case of a short circuit at the output.

### LOW NOISE FIXED FREQUENCY OPERATION

#### Oscillator

The frequency of operation is internally set to 500kHz.

#### Error Amp

The error amplifier is an internally compensated transconductance type (current output) with a transconductance ( $g_m$ ) = 33 microsiemens. The internal 1.23V reference voltage is compared to the voltage at the FB pin to generate an error signal at the output of the error amplifier. A voltage divider from  $V_{OUT}$  to ground programs the output voltage via FB from 2.5V to 5V using the equation:

$$V_{OUT} = 1.23V \cdot [1 + (R1/R2)]$$

#### Current Sensing

Lossless current sensing converts the NMOS switch current signal to a voltage to be summed with the internal slope compensation. The summed signal is compared to the error amplifier output to provide a peak current control command for the PWM. Peak switch current is limited to approximately 850mA independent of input or output voltage. The switch current signal is blanked for 60ns to enhance noise rejection.

#### Zero Current Comparator

The zero current comparator monitors the inductor current to the output and shuts off the synchronous rectifier once this current reduces to approximately 27mA. This prevents the inductor current from reversing in polarity thereby improving efficiency at light loads.

#### Antiringing Control

The antiringing control circuitry prevents high frequency ringing of the SW pin as the inductor current goes to zero in discontinuous mode. The damping of the resonant circuit formed by L and  $C_{SW}$  (capacitance on SW pin) is achieved by placing a 150Ω resistor across the inductor.

#### Synchronous Rectifier

To prevent the inductor current from running away, the PMOS synchronous rectifier is only enabled when  $V_{OUT} > (V_{IN} + 0.1V)$  and the FB pin is  $>0.8V$ .



## OPERATION

### Thermal Shutdown

An internal temperature monitor will start to reduce the peak current limit if the die temperature exceeds 125°C. If the die temperature continues to rise and reaches 160°C, the part will go into thermal shutdown, all switches will be turned off and the soft-start capacitor will be reset. The part will be enabled again when the die temperature drops by about 15°C.

### Burst Mode OPERATION

Portable devices frequently spend extended time in low power or standby mode, only switching to high power consumption when specific functions are enabled. To improve battery life in these types of products, it is important to maintain a high power conversion efficiency over a wide output power range. The LTC3429 provides automatic Burst Mode operation to increase efficiency of the power converter at light loads. Burst Mode operation is initiated if the output load current falls below an internally programmed threshold. This threshold has an inverse dependence on the duty cycle of the converter and also the value of the external inductor (See Typical Performance Characteristics, Output Current Burst Mode Threshold vs  $V_{IN}$ ). Once Burst Mode operation is initiated, only the circuitry required to monitor the output is kept alive and the rest of the device is turned off. This is referred to as the sleep state in which the IC consumes only 20 $\mu$ A from the output capacitor. When the output voltage droops by about 1% from its nominal value, the part wakes up and commences normal PWM operation. The output capacitor recharges and causes the part to re-enter the sleep state if the output load remains less than the Burst Mode threshold. The frequency of this intermittent PWM or burst operation depends on the load current; that is, as the load current drops further below the burst threshold, the LTC3429 turns on less frequently. When the load current increases above the burst threshold, the LTC3429 seamlessly resumes continuous PWM operation. Thus, Burst Mode operation maximizes the efficiency at very light loads by minimizing switching and quiescent losses. However, the output ripple typically increases to about 2% peak-to-peak. Burst Mode ripple can be reduced, in some circumstances, by placing a small phase-lead capacitor ( $C_{PL}$ ) between  $V_{OUT}$  and FB pins (refer to the Block

Diagram). However, this may adversely affect the efficiency and the quiescent current requirement at light loads. Typical values of  $C_{PL}$  range from 15pF to 220pF.

### OUTPUT DISCONNECT AND INRUSH LIMITING

The LTC3429 is designed to allow true output disconnect by eliminating body diode conduction of the internal PMOS rectifier. This allows  $V_{OUT}$  to go to zero volts during shutdown, drawing zero current from the input source. It also allows for inrush current limiting at start-up, minimizing surge currents seen by the input supply. Note that to obtain the advantage of output disconnect, there must not be external Schottky diodes connected between the SWITCH pin and  $V_{OUT}$ .

Note: Board layout is extremely critical to minimize voltage overshoot on the SWITCH pin due to stray inductance. Keep the output filter capacitor as close as possible to the  $V_{OUT}$  pin and use very low ESR/ESL ceramic capacitors tied to a good ground plane. For applications with  $V_{OUT}$  over 4.3V, a Schottky diode is required to limit the peak SWITCH voltage to less than 6V unless some form of external snubbing is employed. This diode must also be placed very close to the pins to minimize stray inductance. See the Applications Information.

### SHORT CIRCUIT PROTECTION

Unlike most boost converters, the LTC3429 allows its output to be short circuited due to its output disconnect feature. The IC has incorporated internal features such as current limit foldback, thermal regulation and thermal shutdown for protection from an excessive overload or short circuit. In the event of a short circuit, the internal soft-start capacitor gets partially discharged. This, in turn, causes the maximum current limit to foldback to a smaller value. In addition to this, a thermal regulation circuit starts to dial back the current limit farther if the die temperature rises above 125°C. If the die temperature still reaches 160°C, the device shuts off entirely.

### $V_{IN} > V_{OUT}$ OPERATION

The LTC3429 will maintain voltage regulation even if the input voltage is above the output voltage. This is achieved

## OPERATION

by terminating the switching of the synchronous PMOS and applying  $V_{IN}$  statically on its gate. This ensures that the slope of the inductor current will reverse during the time current is flowing to the output. Since the PMOS no longer acts as a low impedance switch in this mode, there will be

more power dissipation within the IC. This will cause a sharp drop in the efficiency (see Typical Performance Characteristics, Efficiency vs  $V_{IN}$ ). The maximum output current should be limited in order to maintain an acceptable junction temperature.

## APPLICATIONS INFORMATION

### PCB LAYOUT GUIDELINES

The high speed operation of the LTC3429 demands careful attention to board layout. You will not get advertised performance with careless layout. Figure 2 shows the recommended component placement. A large ground pin copper area will help to lower the chip temperature. A multilayer board with a separate ground plane is ideal, but not absolutely necessary.

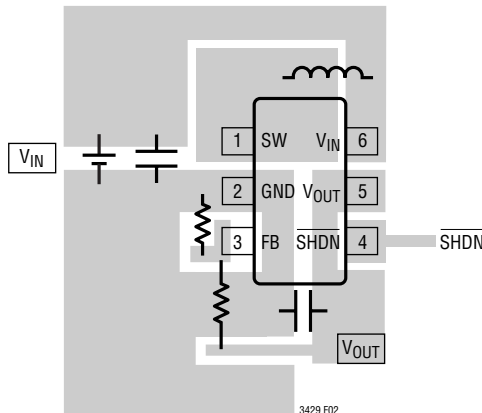

RECOMMENDED COMPONENT PLACEMENT. TRACES CARRYING HIGH CURRENT ARE DIRECT. TRACE AREA AT FB PIN IS SMALL. LEAD LENGTH TO BATTERY IS SHORT

**Figure 2. Recommended Component Placement for Single Layer Board**

### COMPONENT SELECTION

#### Inductor Selection

The LTC3429 can utilize small surface mount and chip inductors due to its fast 500kHz switching frequency. Typically, a 4.7 $\mu$ H inductor is recommended for most applications. Larger values of inductance will allow greater output current capability by reducing the inductor ripple

current. Increasing the inductance above 10 $\mu$ H will increase size while providing little improvement in output current capability.

The approximate output current capability of the LTC3429 versus inductance value is given in the equation below and illustrated graphically in Figure 3.

$$I_{OUT(MAX)} = \eta \cdot \left( I_P - \frac{V_{IN} \cdot D}{f \cdot L \cdot 2} \right) \cdot (1 - D)$$

where:

$\eta$  = estimated efficiency

$I_P$  = peak current limit value (0.6A)

$V_{IN}$  = input (battery) voltage

$D$  = steady-state duty ratio =  $(V_{OUT} - V_{IN})/V_{OUT}$

$f$  = switching frequency (500kHz typical)

$L$  = inductance value

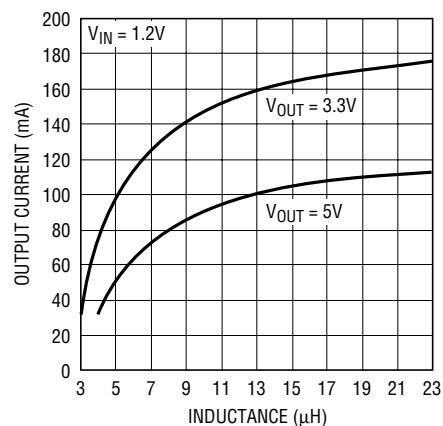

**Figure 3. Maximum Output Current vs Inductance Based On 90% Efficiency**



## APPLICATIONS INFORMATION

The inductor current ripple is typically set for 20% to 40% of the maximum inductor current ( $I_P$ ). High frequency ferrite core inductor materials reduce frequency dependent power losses compared to cheaper powdered iron types, improving efficiency. The inductor should have low ESR (series resistance of the windings) to reduce the  $I^2R$  power losses, and must be able to handle the peak inductor current without saturating. Molded chokes and some chip inductors usually do not have enough core to support the peak inductor currents of 850mA seen on the LTC3429. To minimize radiated noise, use a toroid, pot core or shielded bobbin inductor. See Table 1 for some suggested components and suppliers.

**Table 1. Recommended Inductors**

PART	L ( $\mu$ H)	MAX DCR m $\Omega$	HEIGHT (mm)	VENDOR	
CDRH5D18-4R1	4.1	57	2.0	Sumida www.sumida.com	
CDRH5D18-100	10	124	2.0		
CDRH3D16-4R7	4.7	105	1.8		
CDRH3D16-6R8		170	1.8		
CR43-4R7	4.7	109	3.5		
CR43-100	10	182	3.5		
CMD4D06-4R7MC	4.7	216	0.8		
CMD4D06-3R3MC	3.3	174	0.8		
DS1608-472	4.7	60	2.9		Coilcraft www.coilcraft.com
DS1608-103	10	75	2.9		
DO1608C-472	4.7	90	2.9		
D52LC-4R7M	4.7	84	2.0	Toko www.tokoam.com	
D52LC-100M	10	137	2.0		
LQH32CN4R7M24	4.7	195	2.2	Murata www.murata.com	

### Output and Input Capacitor Selection

Low ESR (equivalent series resistance) capacitors should be used to minimize the output voltage ripple. Multilayer ceramic capacitors are an excellent choice as they have extremely low ESR and are available in small footprints. A 4.7 $\mu$ F to 15 $\mu$ F output capacitor is sufficient for most applications. Larger values up to 22 $\mu$ F may be used to obtain extremely low output voltage ripple and improve transient response. An additional phase lead capacitor may be required with output capacitors larger than 10 $\mu$ F to maintain acceptable phase margin. X5R and X7R dielectric materials are preferred for their ability to maintain capacitance over wide voltage and temperature ranges.

Low ESR input capacitors reduce input switching noise and reduce the peak current drawn from the battery. It follows that ceramic capacitors are also a good choice for input decoupling and should be located as close as possible to the device. A 10 $\mu$ F input capacitor is sufficient for virtually any application. Larger values may be used without limitations. Table 2 shows a list of several ceramic capacitor manufacturers. Consult the manufacturers directly for detailed information on their entire selection of ceramic parts.

**Table 2. Capacitor Vendor Information**

SUPPLIER	WEBSITE
AVX	www.avxcorp.com
Murata	www.murata.com
Taiyo Yuden	www.t-yuden.com

## TYPICAL APPLICATIONS

### Applications Where $V_{OUT} > 4.3V$

When the output voltage is programmed above 4.3V, it is necessary to add a Schottky diode either from SW to  $V_{OUT}$ , or to add a snubber network in order to maintain an acceptable peak voltage on the SW pin. The Schottky diode between SW and  $V_{OUT}$  will provide a peak efficiency

improvement but will negate the output disconnect feature. If output disconnect is required, an active snubber network is suggested as shown below. Examples of Schottky diodes are: MBR0520L, PMEG2010EA, 1N5817 or equivalent.

Application Circuit for  $V_{OUT} > 4.3V$  Where Inrush Current Limiting and Output Disconnect are Required

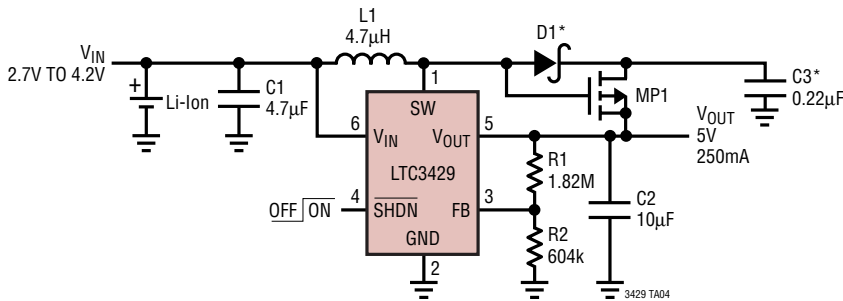

\*LOCATE COMPONENTS CLOSE TO THE PIN  
 C1: TAIYO YUDEN X5R JMK212BJ475MM  
 C2: TAIYO YUDEN X5R JMK212BJ106MM  
 D1: MOTOROLA MBR0520L  
 L1: COILCRAFT D0160C-472  
 MP1: ZETEX ZXM61P02F

Li-Ion to 5V Efficiency

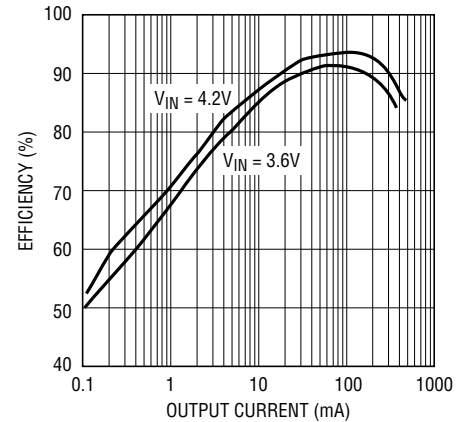

3429 G04

Application Circuit for  $V_{OUT} > 4.3V$  Where Inrush Current Limiting and Output Disconnect are Not Required

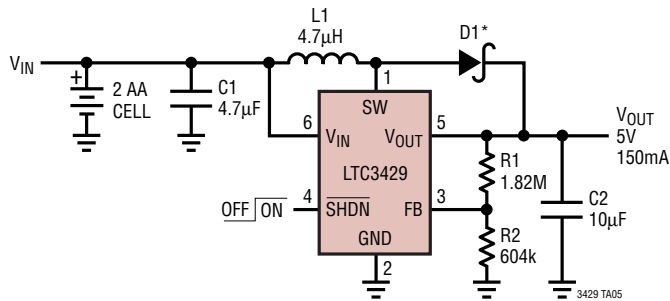

\*LOCATE COMPONENTS CLOSE TO THE PIN  
 C1: TAIYO YUDEN X5R JMK212BJ475MM  
 C2: TAIYO YUDEN X5R JMK212BJ106MM  
 D1: MOTOROLA MBR0520L  
 L1: COILCRAFT D0160C-472

2-Cell to 5V Efficiency

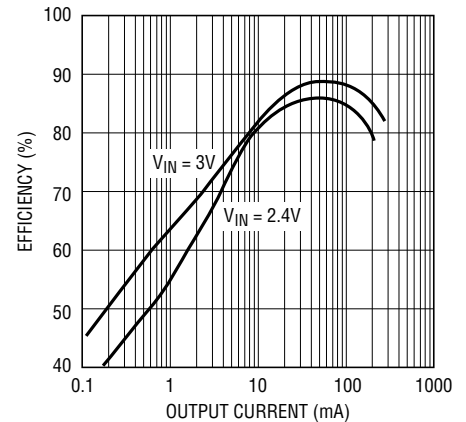

3429 G03

## PACKAGE DESCRIPTION

**S6 Package**  
**6-Lead Plastic TSOT-23**  
 (Reference LTC DWG # 05-08-1636)

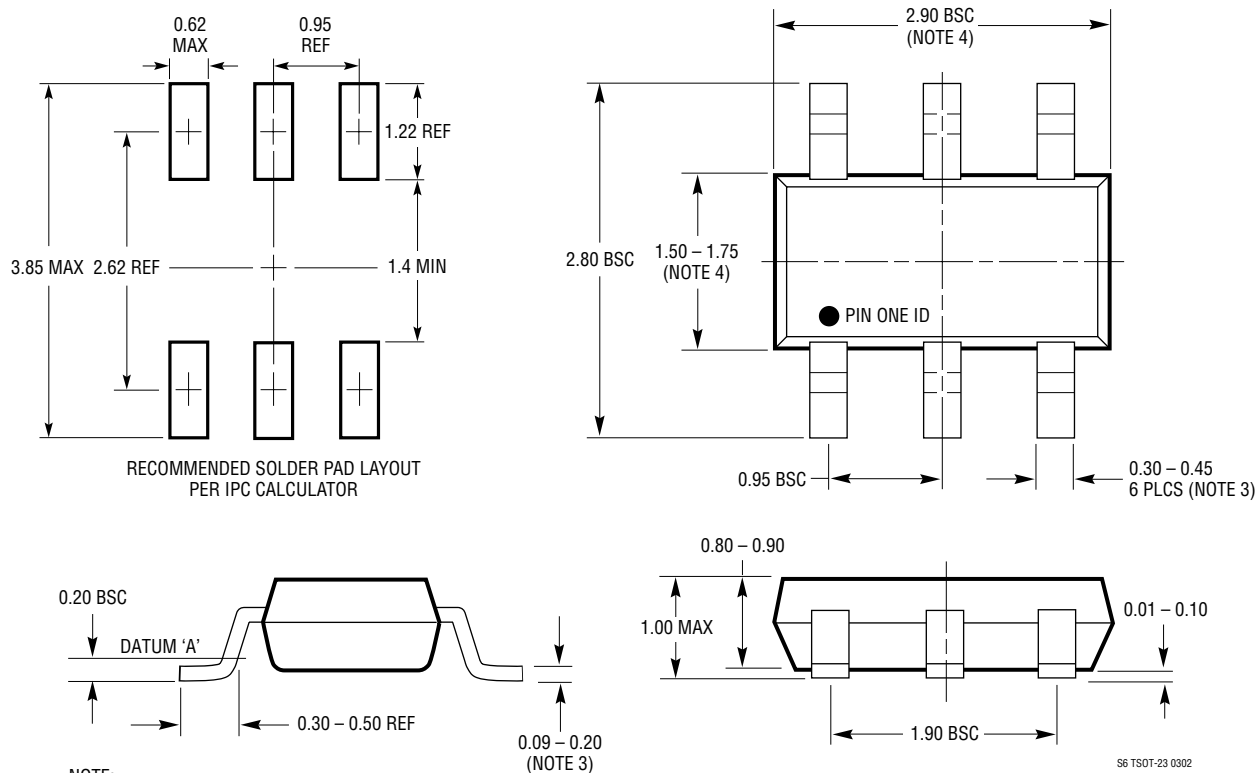

## TYPICAL APPLICATION

Single AA Cell to 2.5V Synchronous Boost Converter

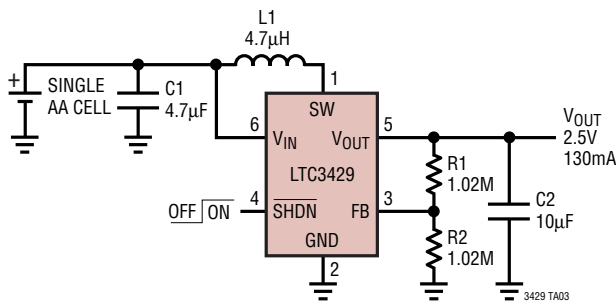

C1: TAIYO YUDEN X5R JMK212BJ475MM  
 C2: TAIYO YUDEN X5R JMK212BJ106MM  
 L1: COILCRAFT D0160C-472

Single AA Cell to 3.3V

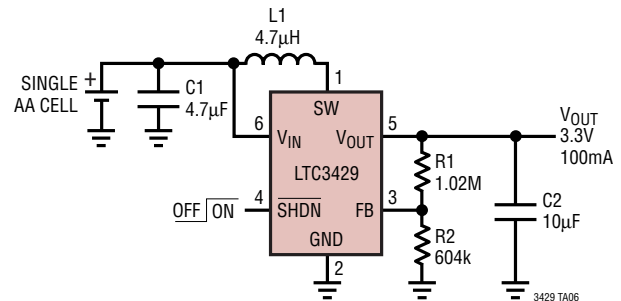

C1: TAIYO YUDEN X5R JMK212BJ475MM  
 C2: TAIYO YUDEN X5R JMK212BJ106MM  
 L1: COILCRAFT D0160C-472

## RELATED PARTS

PART NUMBER	DESCRIPTION	COMMENTS
LT1613	550mA ( $I_{SW}$ ), 1.4MHz High Efficiency Step-Up DC/DC Converter	90% Efficiency, $V_{IN}$ : 0.9V to 10V, $V_{OUT(MAX)}$ = 34V, $I_Q$ = 3mA, $I_{SD}$ < 1µA, ThinSOT
LT1615/LT1615-1	300mA/80mA ( $I_{SW}$ ), High Efficiency Step-Up DC/DC Converters	$V_{IN}$ : 1V to 15V, $V_{OUT(MAX)}$ = 34V, $I_Q$ = 20µA, $I_{SD}$ < 1µA, ThinSOT
LT1618	1.5A ( $I_{SW}$ ), 1.25MHz High Efficiency Step-Up DC/DC Converter	90% Efficiency, $V_{IN}$ : 1.6V to 18V, $V_{OUT(MAX)}$ = 35V, $I_Q$ = 1.8mA, $I_{SD}$ < 1µA,
LTC1700	No $R_{SENSE}^{TM}$ , 530kHz, Synchronous Step-Up DC/DC Controller	95% Efficiency, $V_{IN}$ : 0.9V to 5V, $I_Q$ = 200µA, $I_{SD}$ < 10µA, MS10
LT1930/LT1930A	1A ( $I_{SW}$ ), 1.2MHz/2.2MHz, High Efficiency Step-Up DC/DC Converters	High Efficiency, $V_{IN}$ : 2.6V to 16V, $V_{OUT(MAX)}$ = 34V, $I_Q$ = 4.2mA/5.5mA, $I_{SD}$ < 1µA, ThinSOT
LT1946/LT1946A	1.5A ( $I_{SW}$ ), 1.2MHz/2.7MHz, High Efficiency Step-Up DC/DC Converters	High Efficiency, $V_{IN}$ : 2.45V to 16V, $V_{OUT(MAX)}$ = 34V, $I_Q$ = 32mA, $I_{SD}$ < 1µA, MS8
LT1961	1.5A ( $I_{SW}$ ), 1.25MHz High Efficiency Step-Up DC/DC Converter	90% Efficiency, $V_{IN}$ : 3V to 25V, $V_{OUT(MAX)}$ = 35V, $I_Q$ = 0.9mA, $I_{SD}$ < 6µA, MS8E
LTC3400/LTC3400B	600mA ( $I_{SW}$ ), 1.2MHz, Synchronous Step-Up DC/DC Converters	92% Efficiency, $V_{IN}$ : 0.85V to 5V, $V_{OUT(MAX)}$ = 5V, $I_Q$ = 19µA/300µA, $I_{SD}$ < 1µA, ThinSOT
LTC3401/LTC3402	1A/2A ( $I_{SW}$ ), 3MHz, Synchronous Step-Up DC/DC Converters	97% Efficiency, $V_{IN}$ : 0.5V to 5V, $V_{OUT(MAX)}$ = 5.5V, $I_Q$ = 38µA, $I_{SD}$ < 1µA, MS10
LTC3421	3A ( $I_{SW}$ ), 3MHz, Synchronous Step-Up DC/DC Converter with Output Disconnect	95% Efficiency, $V_{IN}$ : 0.5V to 4.5V, $V_{OUT(MAX)}$ = 5.25V, $I_Q$ = 12µA, $I_{SD}$ < 1µA, QFN24
LTC3425	5A ( $I_{SW}$ ), 8MHz, 4-Phase Synchronous Step-Up DC/DC Converter with Output Disconnect	95% Efficiency, $V_{IN}$ : 0.5V to 4.5V, $V_{OUT(MAX)}$ = 5.25V, $I_Q$ = 12µA, $I_{SD}$ < 1µA, QFN32
LT3464	85mA ( $I_{SW}$ ), High Efficiency Step-Up DC/DC Converter with Integrated Schottky and PNP Disconnect	$V_{IN}$ : 2.3V to 10V, $V_{OUT(MAX)}$ = 34V, $I_Q$ = 25µA, $I_{SD}$ < 1µA, ThinSOT

No  $R_{SENSE}$  is a trademark of Linear Technology Corporation.