

Features

- Differential Linearity Error ± 0.2 LSB
- Integral Linearity Error ± 0.2 LSB
- Single +5V Power Supply Operation Available
- Low Input Capacitance 7pF
- Wide Analog Input Bandwidth 200MHz
- Low Power Consumption 360mW
- CLK/2 Clock Output Pin
- Excellent Temperature Characteristics
- 1:2 Demultiplexed Output
- Internal $1/2$ Frequency Divider Circuit (With Reset Function)
- Compatible with ECL, PECL and TTL Digital Input Levels
- Direct Replacement for Sony CXA3086

Applications

- RGB Graphics Processing (LCD, PDP)
- Digital Communications (QPSK, QAM)
- Magnetic Recording (PRML)

Description

The HI3086 is a 6-bit, high-speed, flash analog-to-digital converter optimized for high speed, low power, and ease of use. With a 140 MSPS encode rate capability and full-power analog bandwidth of 200MHz, this component is ideal for applications requiring the highest possible dynamic performance.

To minimize system cost and power dissipation, only a +5V power supply is required. The HI3086's clock input interfaces directly to TTL, ECL, or PECL logic and will operate with single-ended inputs. The user may select 16-bit demultiplexed output or 8-bit single-channel digital outputs. The demultiplexed mode interleaves the data through two 8-bit channels at $1/2$ the clock rate. Operation in demultiplexed mode reduces the speed and cost of external digital interfaces, while allowing the A/D converter to be clocked to the full 140 MSPS conversion rate.

Fabricated with an advanced bipolar process, the HI3086 is provided in a space-saving 48-lead MQFP surface mount plastic package and is specified over the -20°C to 75°C temperature range.

Ordering Information

PART NUMBER	TEMP. RANGE ($^{\circ}\text{C}$)	PACKAGE	PKG. NO.
HI3086JCQ	-20 to 75	48 Ld MQFP	Q48.12x12-S
HI3086EVAL	25	Evaluation Board	

Pinout

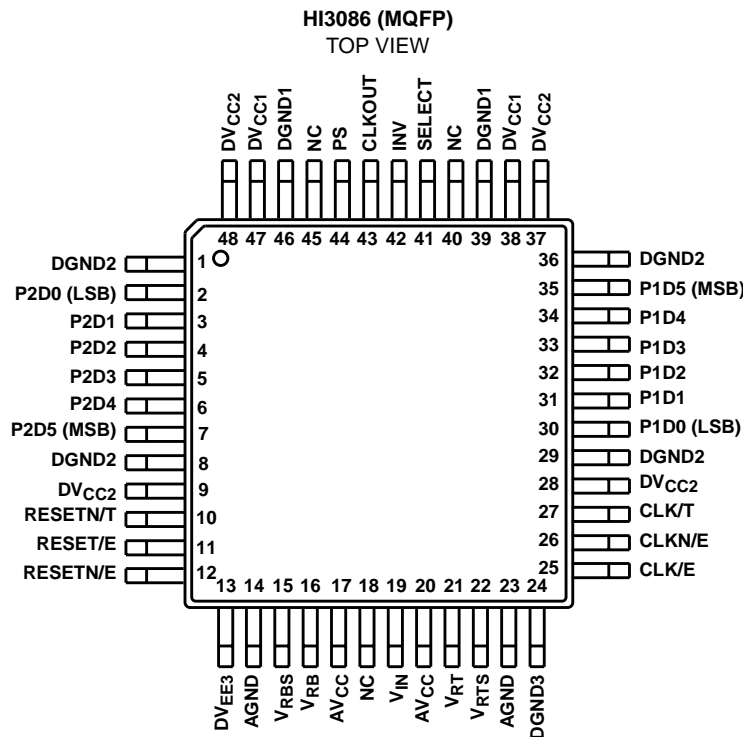

Functional Block Diagram

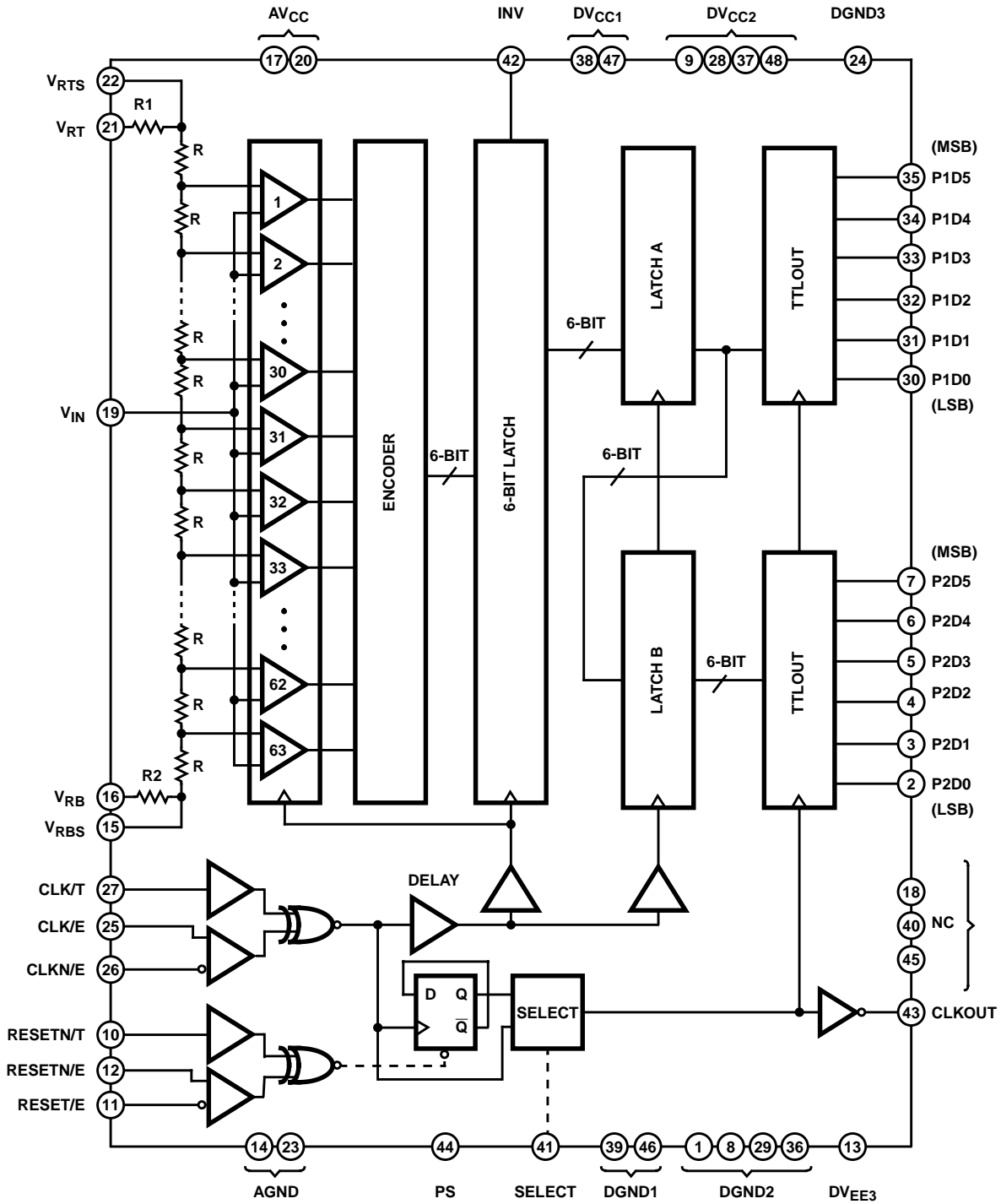

Pin Descriptions

PIN NO.	SYMBOL	I/O	TYPICAL VOLTAGE LEVEL	EQUIVALENT CIRCUIT	DESCRIPTION
14, 23	AGND		GND		Analog Ground. Separated from the digital ground.
17, 20	AV _{CC}		+5V (Typ)		Analog Power Supply. Separated from the digital power supply.
1, 8, 29, 36, 39, 46	DGND1 DGND2		GND		Digital Ground.
9, 28, 37, 38, 47, 48	DV _{CC} 1 DV _{CC} 2		+5V (Typ)		Digital Power Supply.
24	DGND3		+5V (Typ) (With a Single Power Supply)		Digital Power Supply. Ground for ECL input. +5V for PECL and TTL input.
			GND (With Dual Power Supplies)		
13	DVEE3		GND (With a Single Power Supply)		Digital Power Supply. Ground for ECL input. -5V for PECL and TTL input.
			-5V (Typ) (With Dual Power Supplies)		
18, 40, 45	NC				No Connect pin. Not connected with the internal circuits.
25	CLK/E	I	ECL/PECL		Clock input.
26	CLKN/E	I			CLK/E Complementary Input. When left open, this pin goes to the threshold potential. Only CLK/E can be used for operation, but complementary input is recommended to attain fast and stable operation.
12	RESETN/E	I			Reset Input. When the input is set to low level, the built-in CLK frequency divider circuit can be reset.
11	RESET/E	I			RESETN/E Complementary Input. When left open, this pin goes to the threshold voltage. Only RESETN/E can be used for operation.

Pin Descriptions (Continued)

PIN NO.	SYMBOL	I/O	TYPICAL VOLTAGE LEVEL	EQUIVALENT CIRCUIT	DESCRIPTION
27	CLK/T	I	TTL		<p>Clock Input.</p> <p>Reset Input. When left open, this input goes to high level. When the input is set to low level, the built-in CLK frequency divider circuit can be reset.</p>
10	RESETN/T	I			
42	INV	I	TTL		<p>Data Output Polarity Inversion Input. When left open, this input goes to high level. (See Table 1; I/O Correspondence Table).</p> <p>Power Saving Input. When the input is set to low level, the power saving mode is set. In this time the all TTL outputs go into the high impedance state. Normally, set to high level or left open.</p>
44	PS	I	TTL		
41	SELECT		V _{CC} or GND		Data Output Mode Selection. (See Table 2, Operating Mode Table).

Pin Descriptions (Continued)

PIN NO.	SYMBOL	I/O	TYPICAL VOLTAGE LEVEL	EQUIVALENT CIRCUIT	DESCRIPTION
22	V_{RTS}	O	+4.0V (Typ)		Reference Voltage Sense. Bypass to AGND with a 0.1 μ F chip capacitor.
21	V_{RT}	I	$V_{RTS} + R1 \times I_{REF}$		Top Reference Voltage. Bypass to AGND with a 1 μ F tantal capacitor and 0.1 μ F chip capacitor.
16	V_{RB}	I	$V_{RBS} - R2 \times I_{REF}$		Bottom Reference Voltage. Bypass to AGND with a 1 μ F tantal capacitor and a 0.1 μ F chip capacitor.
15	V_{RBS}	O	+2.0V (Typ)		Reference Voltage Sense. Bypass to AGND with a 0.1 μ F chip capacitor.
19	V_{IN}	I	V_{RT} to V_{RB}		Analog Input.
30 to 35	P1D0 to P1D5	O	TTL		Port 1 Side Data Output.
2 to 7	P2D0 to P2D5	O			Port 2 Side Data Output.
43	CLKOUT	O			Clock Output. (See Table 2. Operating Mode Table.)

Absolute Maximum Ratings (T_A = 25°C)

Supply Voltage (AV _{CC} , DV _{CC1} , DV _{CC2})	-0.5V to 7.0V
(DGND3)	-0.5V to 7.0V
(DV _{EE3})	-7.0V to 0.5V
(DGND3 - DV _{EE3})	-0.5V to 7.0V
Analog Input Voltage (V _{IN})	V _{RT} - 2.7V to AV _{CC}
Reference Input Voltage (V _{RT})	2.7V to AV _{CC}
(V _{RB})	V _{IN} - 2.7V to AV _{CC}
(V _{RT} - V _{RB})	2.5V
Digital Input Voltage	
ECL (***/E (Note 2))	DV _{EE3} to 0.5V
PECL (***/E)	-0.5V to DGND3
TTL (***/T, INV PS)	-0.5V to DV _{CC1}
Other (SELECT)	-0.5V to DV _{CC1}
V _{ID} (***/E - ***/N/E (Note 3))	2.7V

Thermal Information

Thermal Resistance (Typical, Note 1)	θ _{JA} (°C/W)
MQFP Package	63
Maximum Junction Temperature (Plastic Package)	150°C
Maximum Storage Temperature Range	-65°C to 150°C
Maximum Lead Temperature (Soldering 10s)	300°C
(MQFP - Lead Tips Only)	

Recommended Operating Conditions

WITH A SINGLE POWER SUPPLY

	MIN	TYP	MAX
Supply Voltage			
DV _{CC1} , DV _{CC2} , AV _{CC}	+4.75	+5.0	+5.25V
DGND1, DGND2, AGND	-0.05	0	+0.05V
DGND3	+4.75	+5.0	+5.25V
DV _{EE3}	-0.05	0	+0.05V
Analog Input Voltage (V _{IN})	V _{RB}	-	V _{RT}
Reference Input Voltage			
V _{RT}	+2.9	-	+4.1V
V _{RB}	1.4	-	+2.6V
V _{RT} - V _{RB}	1.5	-	2.1V
Digital Input Voltage			
ECL (***/E) V _{IH}	DGND3 - 1.05	DGND3 - 0.5V	
PECL (***/E) V _{IL} DGND3	DGND3 - 3.2	DGND3 - 1.4V	
TTL (***/T, INV, PS) V _{IH}	2.0V	-	-
TTL (***/T, INV) V _{IL}	-	-	0.8V
Other (SELECT) V _{IH}	-	DV _{CC1}	-
Other (SELECT) V _{IL}	-	DGND1	-
V _{ID} (Note 3) (***/E - ***/N/E)	0.4	0.8	-
Max Conversion Rate (f _C , Straight Mode)	100	-	-
Units = MSPS			
Max Conversion Rate (f _C , DMUX Mode)	140	-	-
Units = MSPS			
Ambient Temperature (T _A)	-20°C to 75°C		

WITH DUAL POWER SUPPLIES

	MIN	TYP	MAX
Supply Voltage			
DV _{CC1} , DV _{CC2} , AV _{CC}	+4.75	+5.0	+5.25V
DGND1, DGND2, AGND	-0.05	0	+0.05V
DGND3	-0.05	0	+0.05V
DV _{EE3}	-5.5	-5.0	-4.75V
Analog Input Voltage (V _{IN})	V _{RB}	-	V _{RT}
Reference Input Voltage			
V _{RT}	+2.9	-	+4.1V
V _{RB}	1.4	-	+2.6V
V _{RT} - V _{RB}	1.5	-	2.1V
Digital Input Voltage			
ECL (***/E) V _{IH} DGND3	DGND3 - 1.05	DGND3 - 0.5V	
ECL (***/E) V _{IL} DGND3	DGND3 - 3.2	DGND3 - 1.4V	
TTL (***/T, INV) V _{IH}	2.0V	-	-
TTL (***/T, INV) V _{IL}	-	-	0.8V
Other (SELECT) V _{IH}	-	DV _{CC1}	-
Other (SELECT) V _{IL}	-	DGND1	-
V _{ID} (Note 3) (***/E - ***/N/E)	0.4	0.8	-
Max Conversion Rate (f _C , Straight Mode)	100	-	-
Units = MSPS			
Max Conversion Rate (f _C , DMUX Mode)	140	-	-
Units = MSPS			
Ambient Temperature (T _A)	-20°C to 75°C		

CAUTION: Stresses above those listed in "Absolute Maximum Ratings" may cause permanent damage to the device. This is a stress only rating and operation of the device at these or any other conditions above those indicated in the operational sections of this specification is not implied.

NOTES:

1. θ_{JA} is measured with the component mounted on an evaluation PC board in free air.
2. ***/E and ***/T indicate CLK/E and CLK/T, etc. for the pin name.
3. V_{ID}: Input Voltage Differential.

Electrical Specifications

DV_{CC1}, 2, AV_{CC}, DGND3 = +5V, DGND1, 2, AGND, DV_{EE3} = 0V, V_{RT} = 4V, V_{RB} = 2V, T_A = 25°C, PECL Input

PARAMETER	SYMBOL	TEST CONDITIONS	MIN	TYP	MAX	UNITS
Resolution			-	6	-	Bits
DC CHARACTERISTICS						
Integral Linearity Error	E _{IL}	V _{IN} = 2V _{P-P} , f _C = 5 MSPS	-	-	±0.2	LSB
Differential Linearity Error	E _{DL}		-	-	±0.2	LSB

HI3086

Electrical Specifications $DV_{CC1,2}, AV_{CC}, DGND3 = +5V, DGND1, 2, AGND, DV_{EE3} = 0V, V_{RT} = 4V, V_{RB} = 2V,$
 $T_A = 25^{\circ}C, PECL$ Input **(Continued)**

PARAMETER	SYMBOL	TEST CONDITIONS	MIN	TYP	MAX	UNITS
ANALOG INPUT						
Analog Input Capacitance	C_{IN}	$V_{IN} = +3.0V + 0.07V_{RMS}$	-	7	-	pF
Analog Input Resistance	R_{IN}		16	-	150	k Ω
Analog Input Current	I_{IN}		0	-	125	μA
REFERENCE INPUT						
Reference Resistance (Note 5)	R_{REF}		160	225	308	Ω
Reference Current (Note 6)	I_{REF}		6.5	9.0	12.5	mA
Residual Resistance	R1		3.0	4.2	5.7	Ω
	R2	3.0	4.2	5.7	Ω	
DIGITAL INPUT (ECL, PECL)						
Digital Input Voltage: High	V_{IH}		DGND3 -1.05	-	DGND3 -0.5	V
Digital Input Voltage: Low	V_{IL}		DGND3 -3.2	-	DGND3-1.4	V
Threshold Voltage	V_{TH}		-	DGND3 -1.2	-	V
Digital Input Current: High	I_{IH}	$V_{IH} = DGND3 -0.8V$	-50	-	+50	μA
Digital Input Current: Low	I_{IL}	$V_{IL} = DGND3 -1.6V$	-75	-	0	μA
Digital Input Capacitance			-	-	5	pF
DIGITAL INPUT (TTL)						
Digital Input Voltage: High	V_{IH}		2.0	-	-	V
Digital Input Voltage: Low	V_{IL}		-	-	0.8	V
Threshold Voltage	V_{TH}		-	1.5	-	V
Digital Input Current: High	I_{IH}	$V_{IH} = 3.5V$	-50	-	0	μA
Digital Input Current: Low	I_{IL}	$V_{IL} = 0.2V$	-500	-	0	μA
Digital Input Capacitance			-	-	5	pF
DIGITAL OUTPUT (TTL)						
Digital Output Voltage: High	V_{OH}	$I_{OH} = -2mA$	2.4	-	-	V
Digital Output Voltage: Low	V_{OL}	$I_{OL} = 1mA$	-	-	0.5	V
Leakage Current	I_{OZ}	Power Saving Mode	-15	-	70	μA
SWITCHING CHARACTERISTICS						
Maximum Conversion Rate	f_C	DMUX Mode	140	-	-	MSPS
Aperture Jitter	t_{AJ}		-	10	-	ps
Sampling Delay	t_{DS}		3	4.5	6	ns
Clock High Pulse Width	t_{PW1}	CLK	2.9	-	-	ns
Clock Low Pulse Width	t_{PW0}	CLK	2.9	-	-	ns
Reset Signal Setup	t_{RS}	RESETN - CLK	3.5	-	-	ns
RESET Signal Hold	t_{RH}	RESETN - CLK	0	-	-	ns
CLKOUT Output Delay	t_{DCLK}	($C_L = 5pF$)	3.5	7	9	ns
Data Output Delay (Note 7)	t_{DO1}	DMUX Mode ($C_L = 5pF$)	t (Note 6)	t + 1	t + 2	ns
	t_{DO2}	($C_L = 5pF$)	4.5	8	10	ns
Output Rise Time	t_r	0.8V to 2.0V ($C_L = 5pF$)	-	2	-	ns
Output Fall Time	t_f	0.8V to 2.0V ($C_L = 5pF$)	-	2	-	ns

HI3086

Electrical Specifications $DV_{CC1,2}, AV_{CC}, DGND3 = +5V, DGND1,2, AGND, DV_{EE3} = 0V, V_{RT} = 4V, V_{RB} = 2V,$
 $T_A = 25^\circ C, PECL$ Input **(Continued)**

PARAMETER	SYMBOL	TEST CONDITIONS	MIN	TYP	MAX	UNITS
DYNAMIC CHARACTERISTICS						
Input Bandwidth		$V_{IN} = 2V_{P-P}, -3dB$	200	-	-	MHz
S/N Ratio		$f_C = 140$ MSPS, $f_{IN} = 1kHz$ Full Scale, DMUX Mode	-	37.0	-	dB
		$f_C = 140$ MSPS, $f_{IN} = 34.999MHz$ Full Scale, DMUX Mode	-	34.5	-	dB
Error Rate		$f_C = 140$ MSPS, $f_{IN} = 1kHz$ Full Scale, DMUX Mode Error > 4 LSB	-	-	10^{-12}	TPS (Note 8)
		$f_C = 140$ MSPS, $f_{IN} = 34.999MHz$ Full Scale, DMUX Mode Error > 4 LSB	-	-	10^{-9}	TPS
		$f_C = 100$ MSPS, $f_{IN} = 24.999MHz$ Full Scale, Straight Mode Error > 4 LSB	-	-	10^{-9}	TSP
POWER SUPPLY						
Supply Current	I_{CC}		54.0	67.5	90.0	mA
Supply Current	I_{EE}		0.4	0.6	0.8	mA
Power Consumption (Note 9)	P_D		290	360	470	mW
Supply Current	$I_{CC} + I_{EE}$	Power Saving Mode	2.0	-	8.0	mA
Power Consumption	P_D	Power Saving Mode	28.0	-	58.0	mW

NOTES:

4. R_{REF} : Resistance value between V_{RT} and V_{RB} .

5.
$$I_{REF} = \frac{V_{RT} - V_{RB}}{R_{REF}}$$

6.
$$t = \frac{1}{f_C}$$

7. TPS: Times Per Sample.

8.
$$P_D = (I_{CC} + I_{EE}) \cdot V_{CC} + \frac{(V_{RT} - V_{RB})^2}{V_{REF}}$$

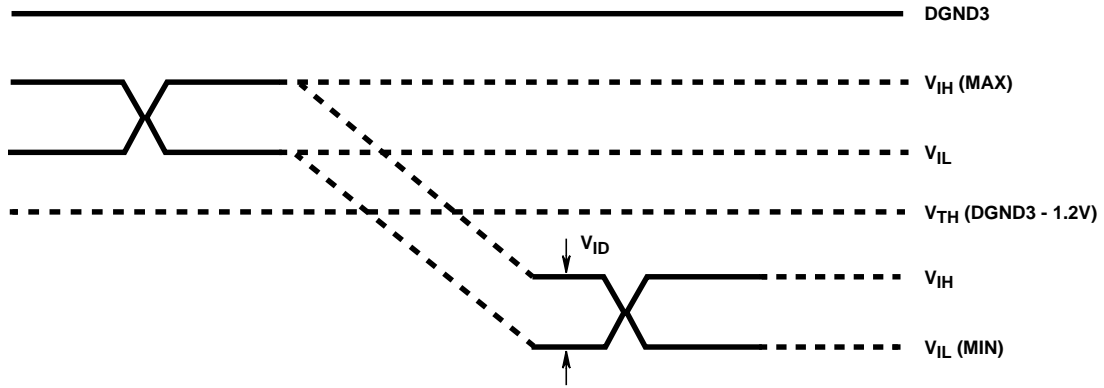

FIGURE 1. ECL AND PECL SWITCHING LEVEL

TABLE 1. I/O CORRESPONDENCE

V _{IN}	STEP	INV										
		1		0								
		D5	D0	D5	D0							
V _{RTS}	63	1	1	1	1	1	0	0	0	0	0	
	62	1	1	1	1	0	0	0	0	0	1	
	•	•	•	•	•	•	•	•	•	•	•	
	•	•	•	•	•	•	•	•	•	•	•	
	•	•	•	•	•	•	•	•	•	•	•	
	32	1	0	0	0	0	0	0	1	1	1	1
V _{RBS}	31	0	1	1	1	1	1	1	0	0	0	0
	•	•	•	•	•	•	•	•	•	•	•	•
	•	•	•	•	•	•	•	•	•	•	•	•
	•	•	•	•	•	•	•	•	•	•	•	•
	•	•	•	•	•	•	•	•	•	•	•	•
	1	0	0	0	0	0	1	1	1	1	1	0
V _{RBS}	0	0	0	0	0	0	1	1	1	1	1	

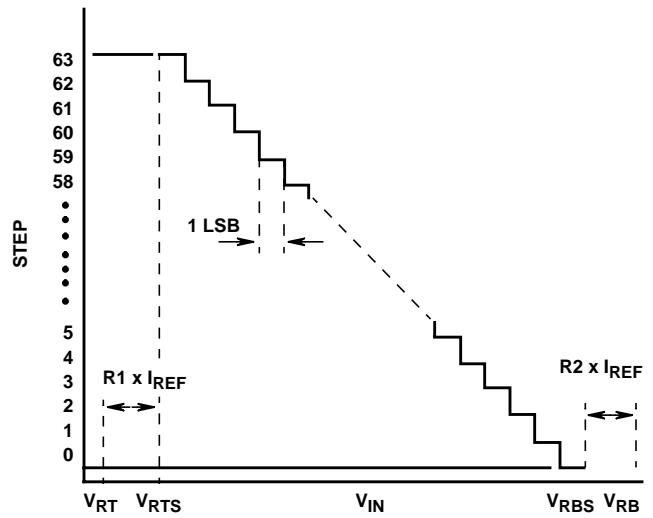

FIGURE 2.

Test Circuits

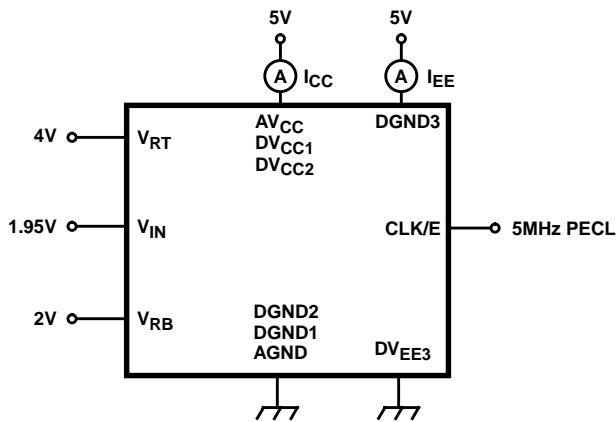

FIGURE 3. CURRENT CONSUMPTION MEASUREMENT CIRCUIT

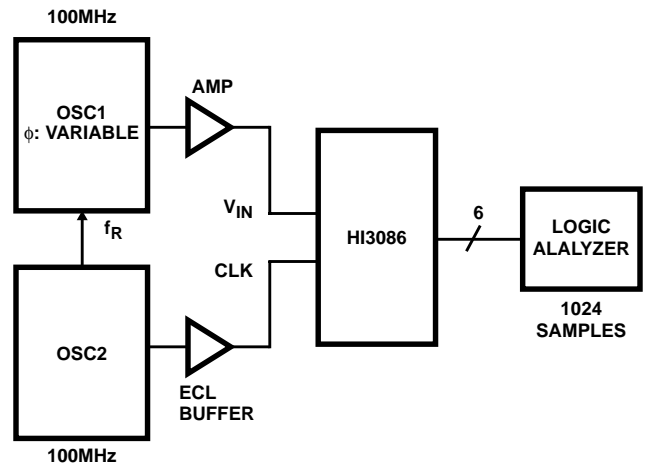

FIGURE 4. SAMPLING DELAY MEASUREMENT CIRCUIT
APERTURE JITTER MEASUREMENT CIRCUIT

Test Circuits (Continued)

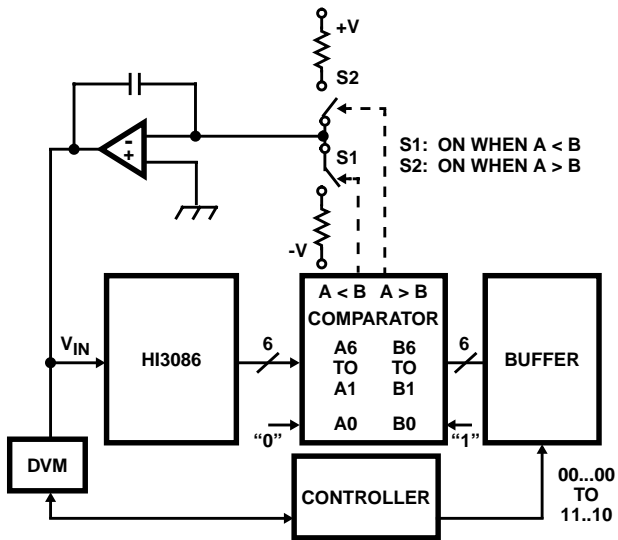
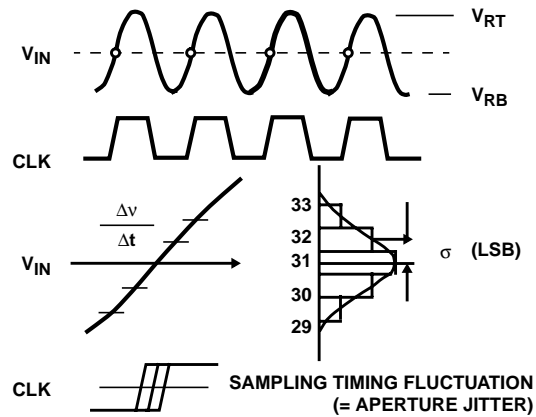

FIGURE 5. INTEGRAL LINEARITY ERROR MEASUREMENT CIRCUIT DIFFERENTIAL LINEARITY ERROR MEASUREMENT CIRCUIT



NOTE: Where σ (LSB) is the deviation of the output codes when the largest slew rate point is sampled at the clock which has exactly the same frequency as the analog input signal, the aperture jitter t_{AJ} is:

$$t_{AJ} = \sigma / \frac{\Delta v}{\Delta T} = \sigma / \left(\frac{64}{2} \times 2\pi f \right)$$

FIGURE 6. APERTURE JITTER MEASUREMENT METHOD

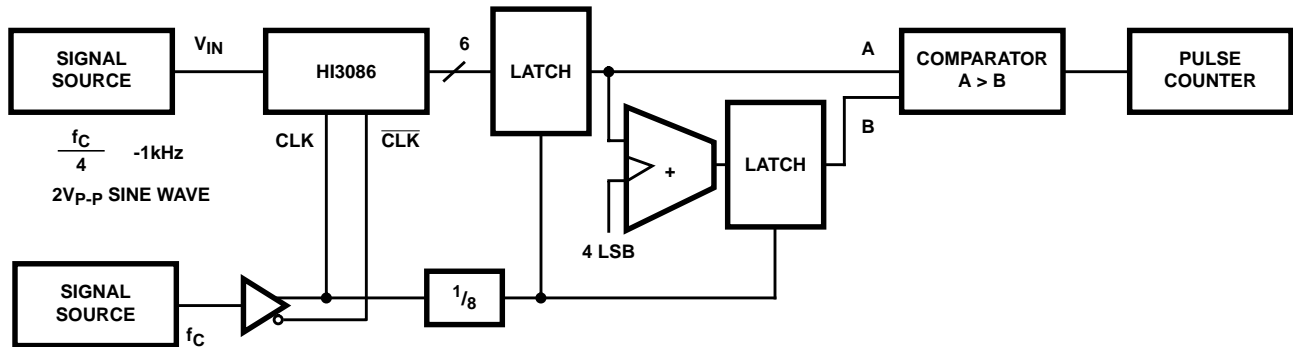

FIGURE 7. ERROR RATE MEASUREMENT CIRCUIT

Operating Modes

The HI3086 has two types of operating modes which are selected with Pin 41 (SELECT).

TABLE 2. OPERATING MODE

OPERATING MODE	SELECT	MAXIMUM CONVERSION RATE	DATA OUTPUT	CLOCK OUTPUT
DMUX Mode	V _{CC}	140 Mbps	Demultiplexed Output 70 Mbps	The input clock is $1/2$ frequency divided and output at 70MHz.
Straight Mode	GND	100 Mbps	Straight Output 100 Mbps	The input clock is inverted and output at 100MHz.

Demux Mode (See Figures 19, 20, 21).

Set the SELECT pin to V_{CC} for this mode. In this mode, the clock frequency is divided by 2 in the IC, and the data is output after being demultiplexed by this $1/2$ frequency divided clock. The $1/2$ frequency divided clock, which has adequate setup time and hold time for the output data, is output from the CLKOUT pin.

When using multiple HI3086 units in parallel in this mode, differences in the start timing of the $1/2$ frequency divided clock may cause operation as shown in Figures 8 and 9. As a countermeasure, the HI3086 is equipped with a function which resets the $1/2$ frequency divided clock. When resetting this clock, the RESET pulse must be input to the RESET pin. See the Timing Charts for the RESET pulse input timing. The A/D converter can operate at f_C (Min) = 140 MSPS in this mode.

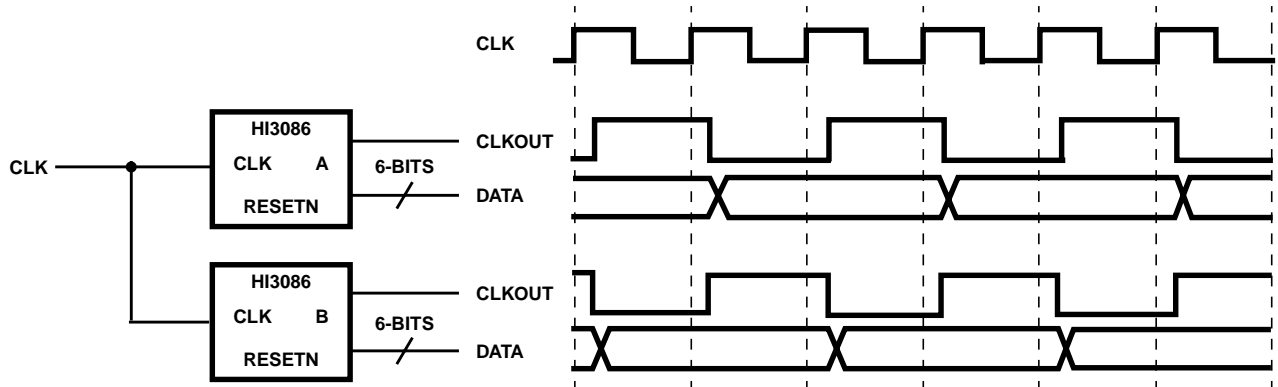

FIGURE 8. WHEN THE RESET PULSE IS NOT USED

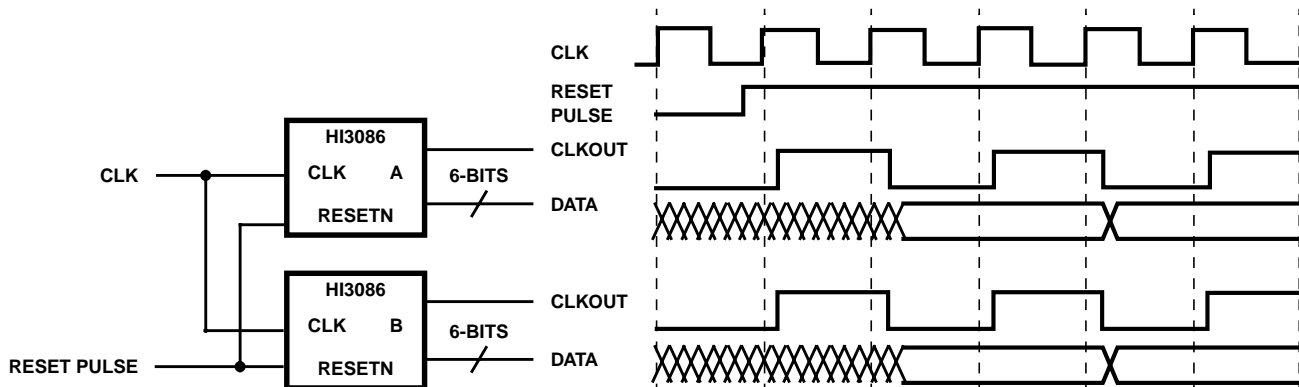

FIGURE 9. WHEN THE RESET PULSE IS USED

Straight Mode (See Figures 22, 23, 24 and 25).

Set the SELECT pin to GND for this mode. In this mode, data output can be obtained in accordance with the clock frequency applied to the A/D converter for applications which use the clock applied to the A/D converter as the system clock.

The A/D converter can operate at f_C (Min) = 100 MSPS in this mode.

Digital Input Level and Supply Voltage Settings

The logic input level for the HI3086 supports ECL, PECL and TTL levels. The power supplies (D_{VEE3} , D_{GND3}) for the logic input block must be set to match the logic input (CLK and RESET signals) level.

TABLE 3. LOGIC INPUT LEVEL AND POWER SUPPLY SETTINGS

DIGITAL INPUT LEVEL	D_{VEE3}	D_{GND3}	SUPPLY VOLTAGE	APPLICATION CIRCUITS
ECL	-5V	0V	±5V	Figures 19, 22
PECL	0V	+5V	+5V	Figures 20, 23
TTL	0V	+5V	+5V	Figures 21, 24, 25

Timing Waveforms

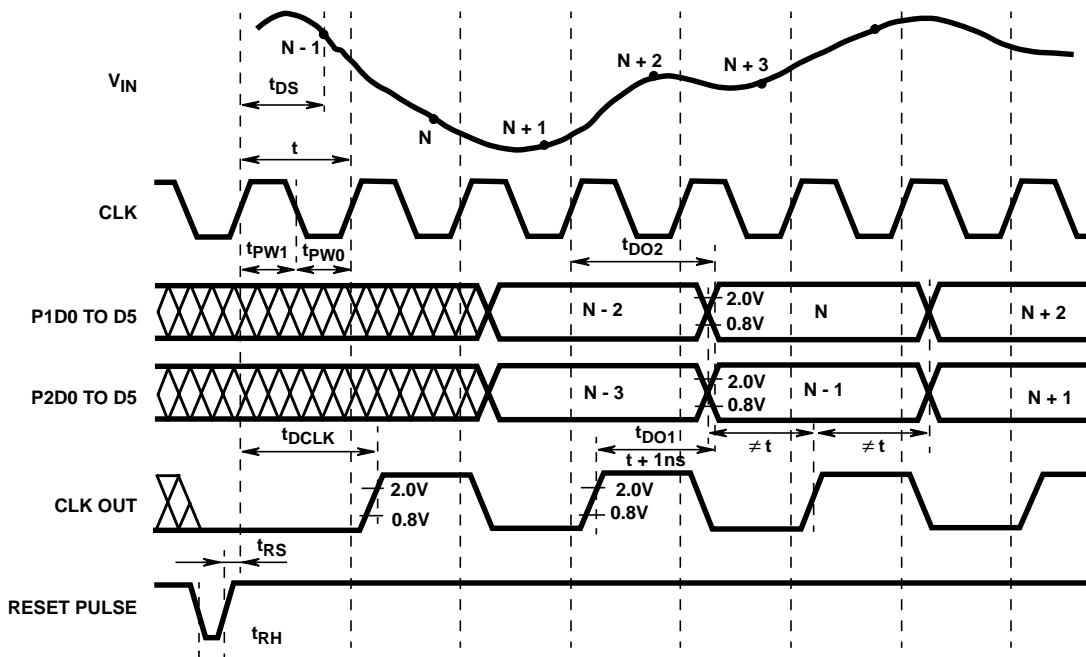

FIGURE 10. DEMUX MODE TIMING CHART (SELECT = V_{CC})

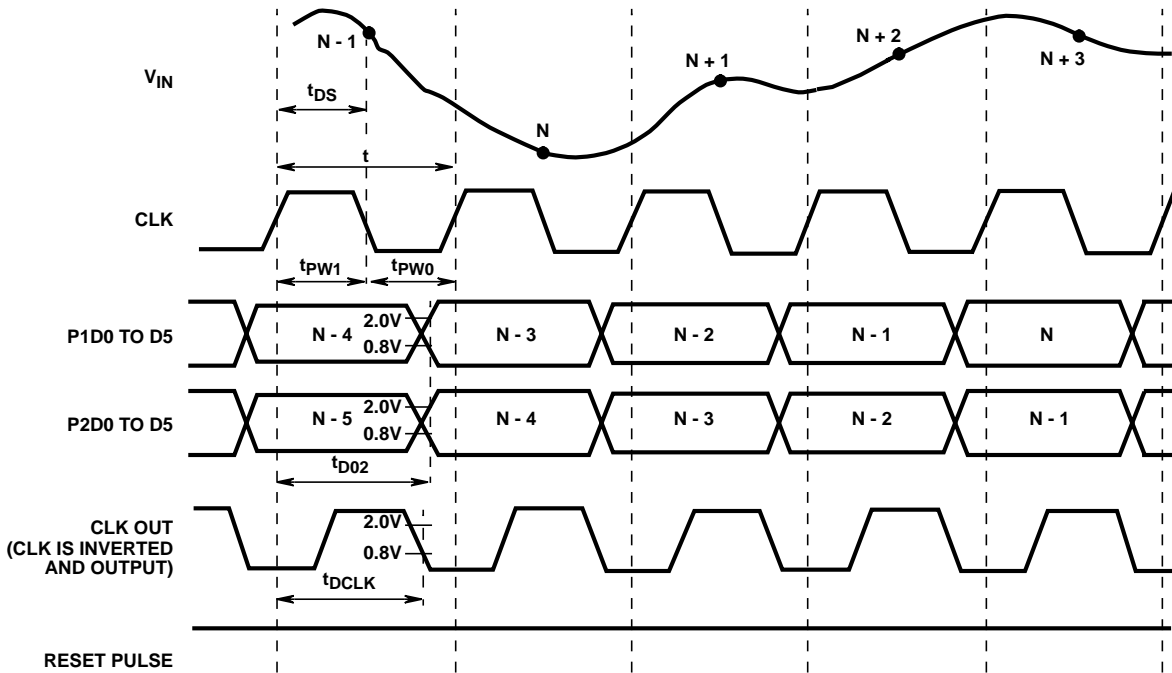

FIGURE 11. STRAIGHT MODE TIMING CHART (SELECT = GND)

Notes on Operation

- The HI3086 is a high-speed A/D converter which is capable of TTL, ECL and PECL level clock input. Characteristic impedance should be properly matched to ensure optimum performance during high-speed operation.
- The power supply and grounding have a profound influence on converter performance. The power supply and grounding method are particularly important during high-speed operation. General points for caution are as follows:
 - The ground pattern should be as large as possible. It is recommended to make the power supply and ground patterns wider at an inner layer using a multi-layer board.
 - To prevent interference between AGND and DGND and between AV_{CC} and DV_{CC}, make sure the respective patterns are separated. To prevent a DC offset in the power supply pattern, connect the AV_{CC} and DV_{CC} lines at one point each via a ferrite-bead filter. Shorting the AGND and DGND patterns in one place immediately under the A/D converter improves A/D converter performance.
 - Ground the power supply pins (AV_{CC}, DV_{CC1}, DV_{CC2}, DV_{EE3}) as close to each pin as possible with a 0.1μF or larger ceramic chip capacitor. (Connect the AV_{CC} pin to the AGND pattern and the DV_{CC1}, DV_{CC2}, DV_{EE3} pins to the DGND pattern.)
 - The digital output wiring should be as short as possible. If the digital output wiring is long, the wiring capacitance will increase, deteriorating the output slew rate and resulting in reflection to the output waveform since the original output slew rate is quite fast.
- The analog input pin V_{IN} has an input capacitance of approximately 7pF. To drive the A/D converter with proper frequency response, it is necessary to prevent performance deterioration due to parasitic capacitance or parasitic inductance by using a large capacity drive circuit; keeping wiring as short as possible, and using chip parts for resistors and capacitors, etc.
- The V_{RT} and V_{RB} pins must have adequate bypass to protect them from high-frequency noise. Bypass them to AGND with approximately 1μF tantal capacitor and, 0.1μF chip capacitor as short as possible.
- The offset for residual is generated each for the reference voltage pins V_{RT} and V_{RB}. When the offset voltage has no influence on the IC operation, the voltage should be applied to the V_{RT} and V_{RB} pins directly, keeping the V_{RBS} pin open. When the reference voltage is to be supplied to these pins precisely, form the feedback loop circuit with V_{RT} and V_{RB} as a force pin and adjust the offset voltage to be 0V. See Figure 25 for details.
- If the CLKN/E pin is not used, bypass this pin to DGND with an approximately 0.1μF capacitor. At this time, approximately DGND3 -1.2V voltage is generated. However, this is not recommended for use as threshold voltage V_{BB} as it is too weak.
- When the digital input level is ECL or PECL level, ***/E pins should be used and ***/T pins left open. When the digital input level is TTL, ***/T pins should be used and ***/E pins left open.

Typical Performance Curves

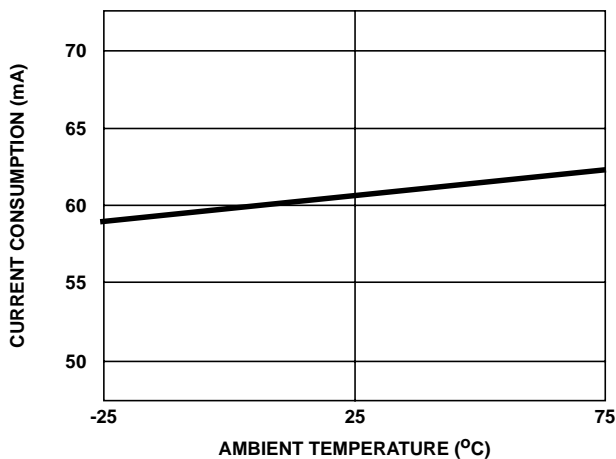

FIGURE 12. CURRENT CONSUMPTION vs AMBIENT TEMPERATURE CHARACTERISTICS

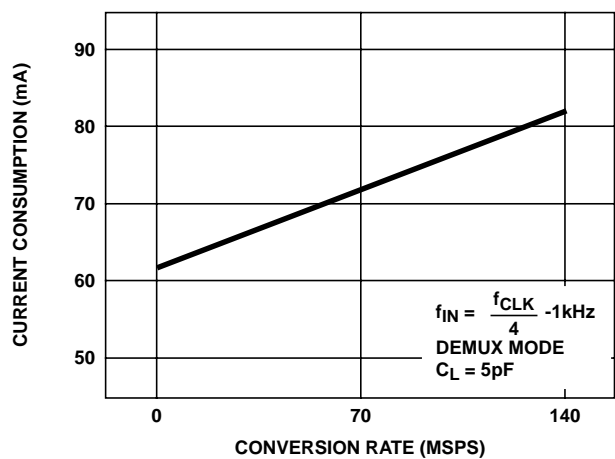

FIGURE 13. CURRENT CONSUMPTION vs CONVERSION RATE CHARACTERISTICS

Typical Performance Curves (Continued)

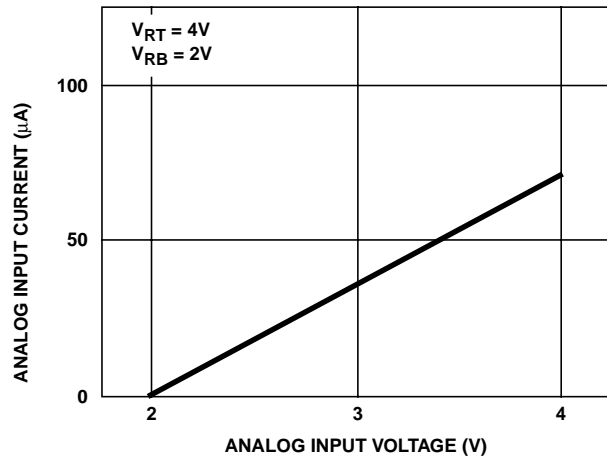

FIGURE 14. ANALOG INPUT CURRENT vs ANALOG INPUT VOLTAGE CHARACTERISTICS

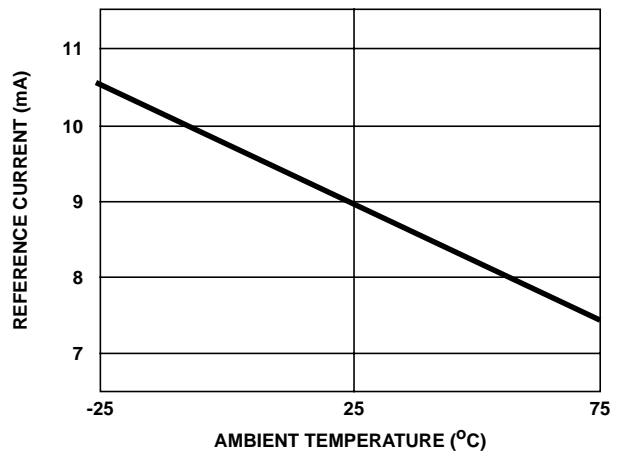

FIGURE 15. REFERENCE CURRENT vs AMBIENT TEMPERATURE CHARACTERISTICS

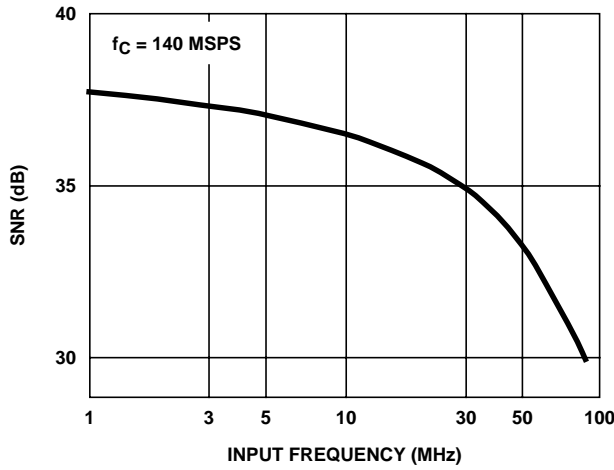

FIGURE 16. SNR vs INPUT FREQUENCY RESPONSE

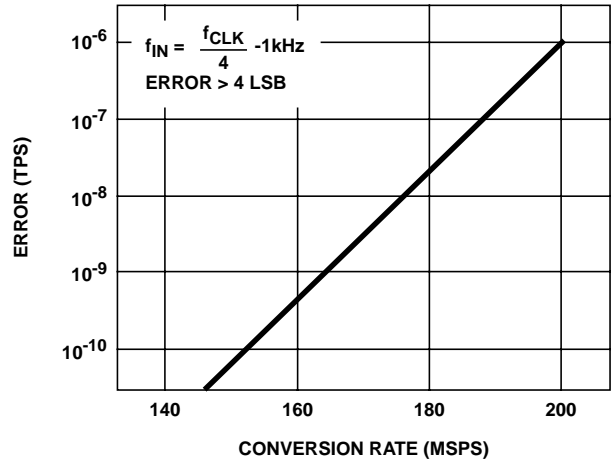

FIGURE 17. ERROR RATE vs CONVERSION RATE CHARACTERISTICS

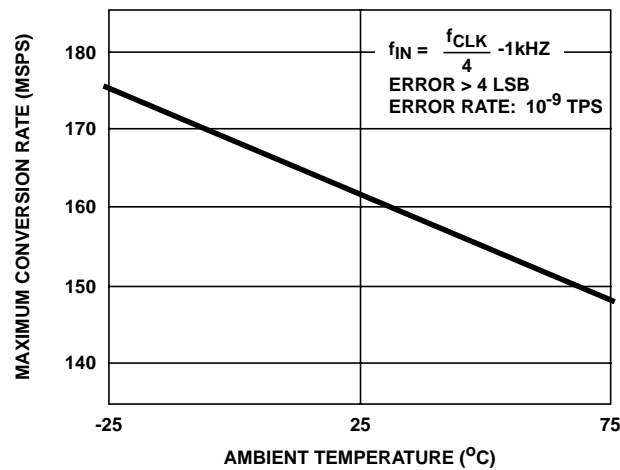

FIGURE 18. MAXIMUM CONVERSION RATE vs AMBIENT TEMPERATURE CHARACTERISTICS

Application Circuits

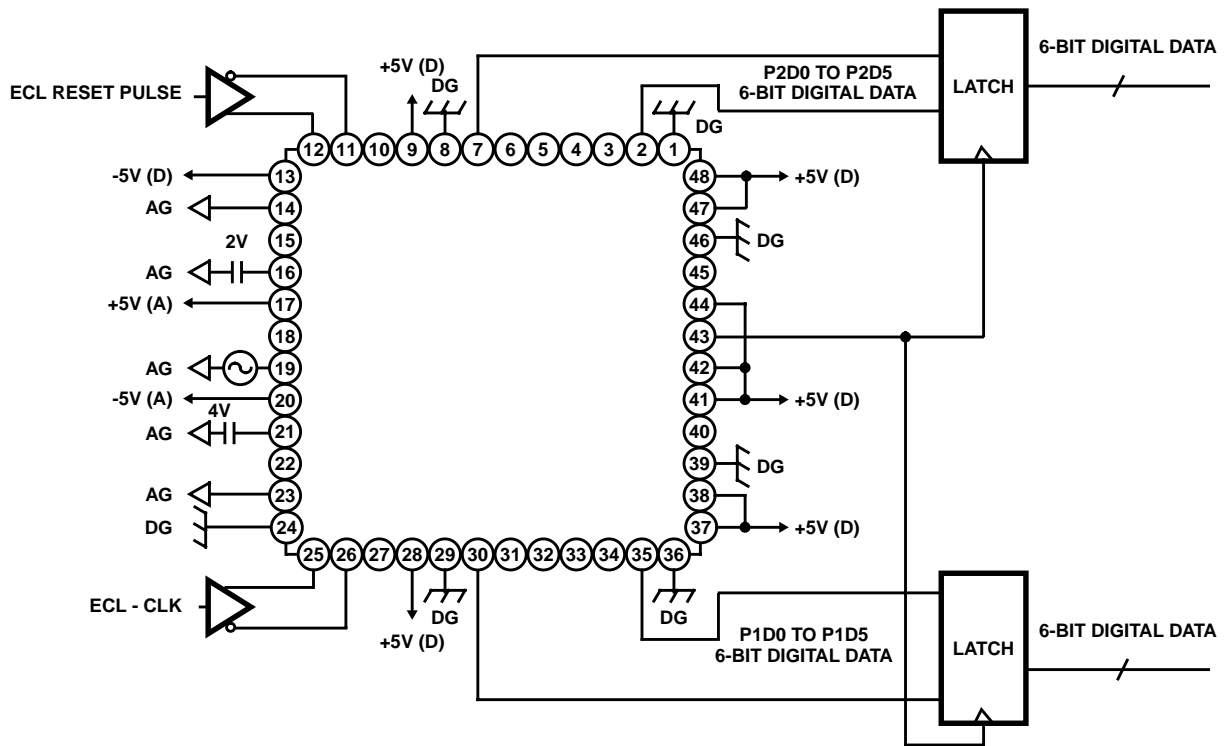

FIGURE 19. DEMUX ECL INPUT

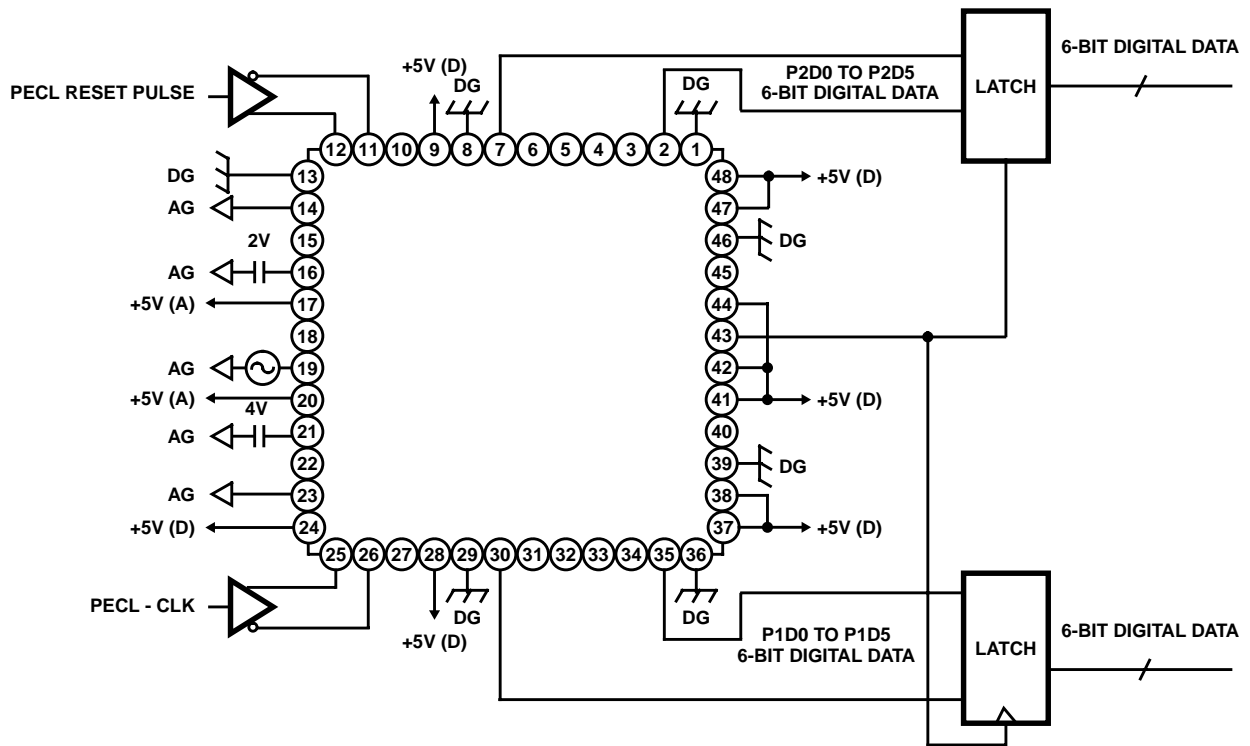

FIGURE 20. DEMUX PECL INPUT

Application Circuits (Continued)

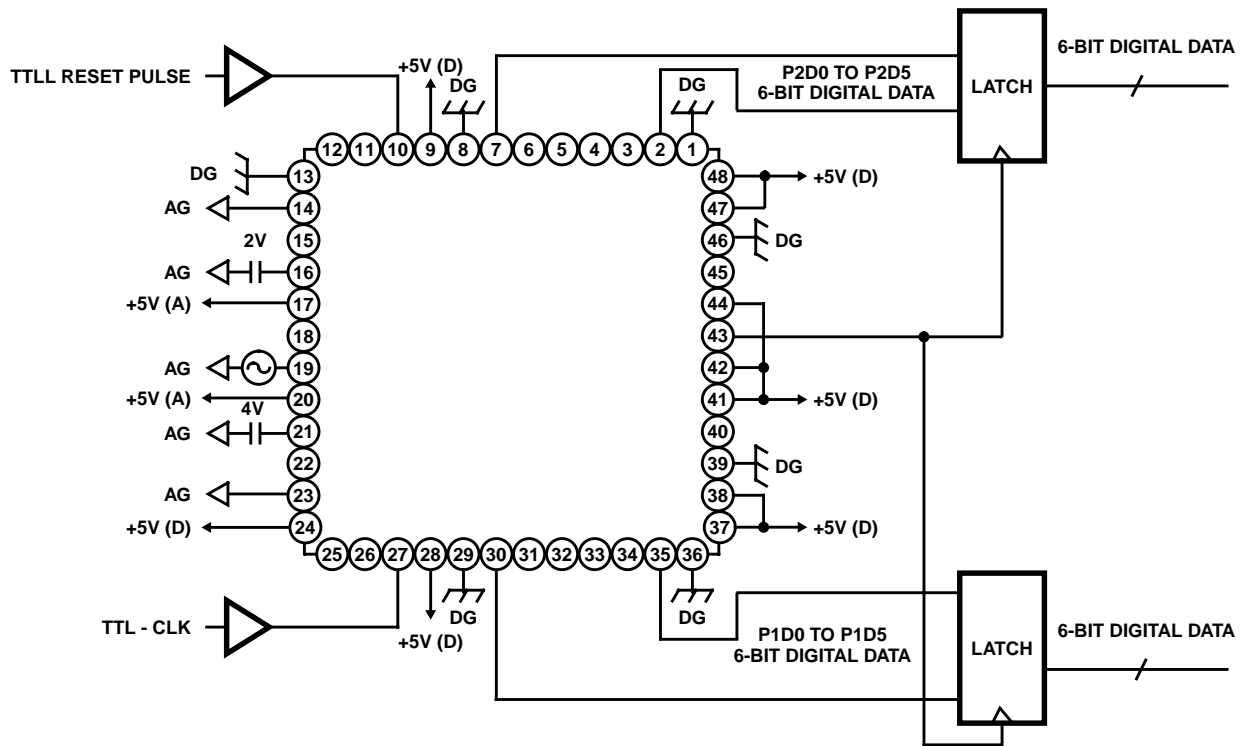

FIGURE 21. DMUX TTL INPUT

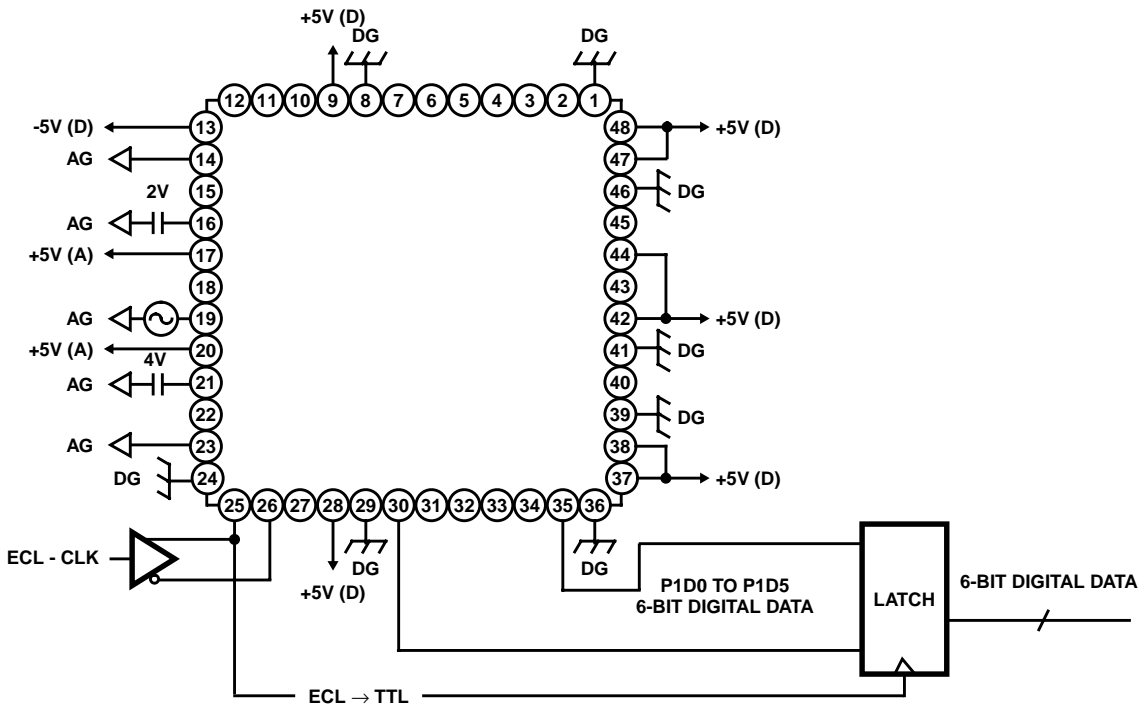

FIGURE 22. STRAIGHT ECL INPUT

Application Circuits (Continued)

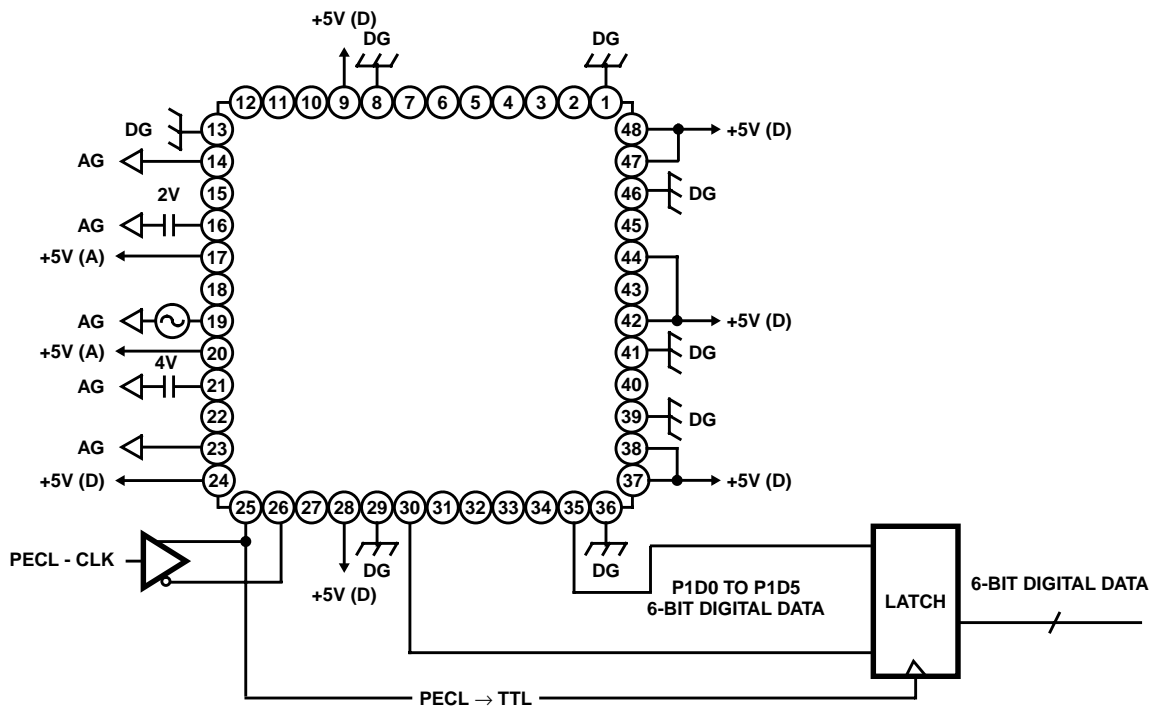

FIGURE 23. STRAIGHT PECL INPUT

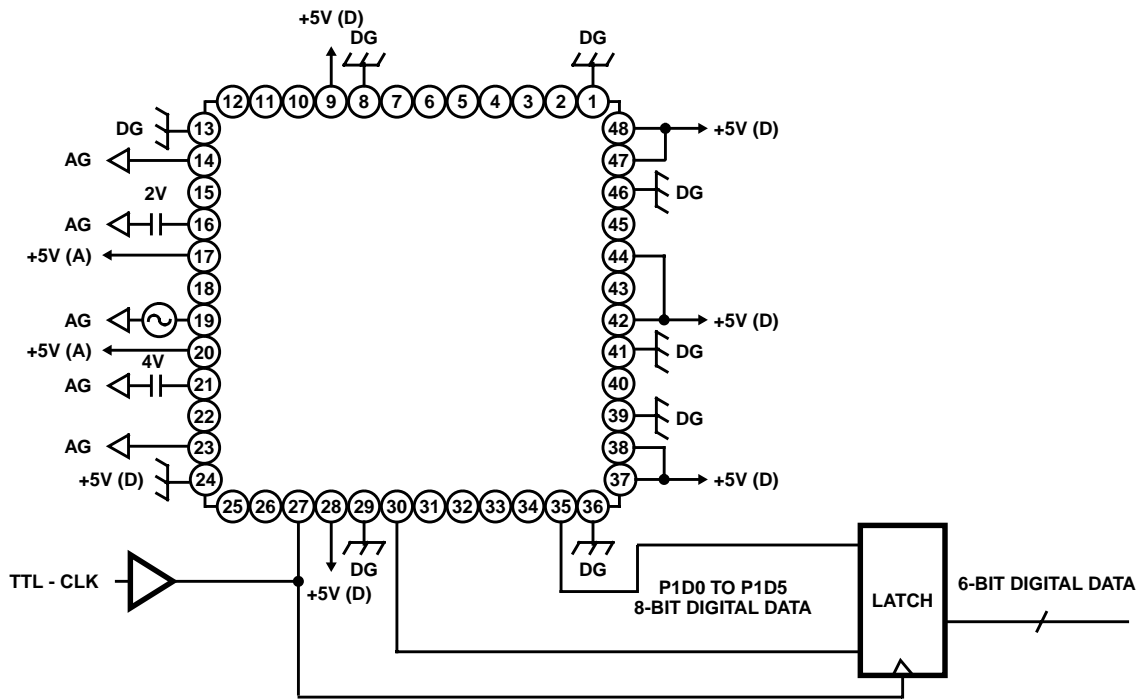

FIGURE 24. STRAIGHT TTL INPUT

Application Circuits (Continued)

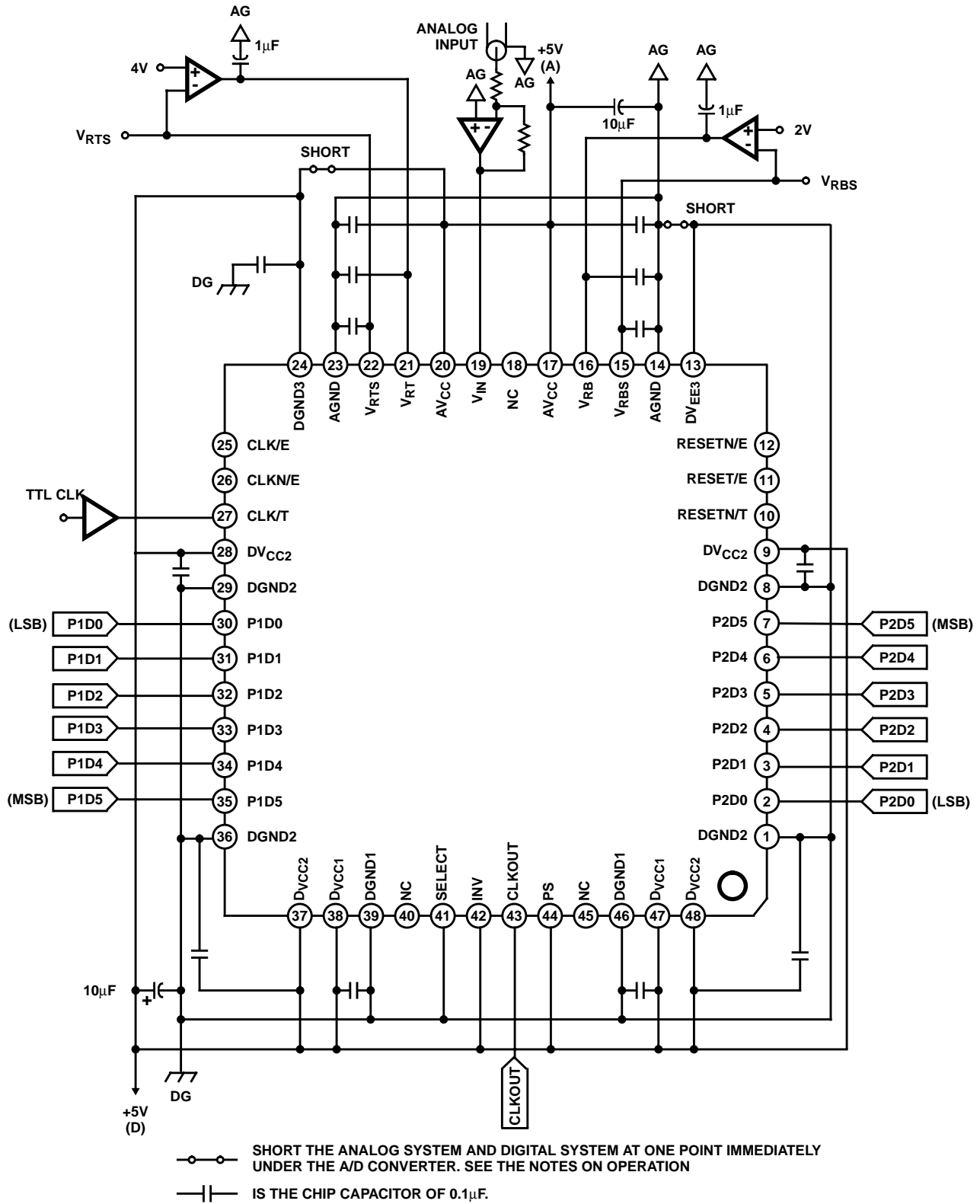

FIGURE 25. STRAIGHT MODE TTL I/O (WHEN A SINGLE POWER SUPPLY IS USED)

All Intersil semiconductor products are manufactured, assembled and tested under **ISO9000** quality systems certification.

Intersil products are sold by description only. Intersil Corporation reserves the right to make changes in circuit design and/or specifications at any time without notice. Accordingly, the reader is cautioned to verify that data sheets are current before placing orders. Information furnished by Intersil is believed to be accurate and reliable. However, no responsibility is assumed by Intersil or its subsidiaries for its use; nor for any infringements of patents or other rights of third parties which may result from its use. No license is granted by implication or otherwise under any patent or patent rights of Intersil or its subsidiaries.

For information regarding Intersil Corporation and its products, see web site <http://www.intersil.com>

Sales Office Headquarters

NORTH AMERICA

Intersil Corporation
P. O. Box 883, Mail Stop 53-204
Melbourne, FL 32902
TEL: (321) 724-7000
FAX: (321) 724-7240

EUROPE

Intersil SA
Mercure Center
100, Rue de la Fusee
1130 Brussels, Belgium
TEL: (32) 2.724.2111
FAX: (32) 2.724.22.05

ASIA

Intersil (Taiwan) Ltd.
Taiwan Limited
7F-6, No. 101 Fu Hsing North Road
Taipei, Taiwan
Republic of China
TEL: (886) 2 2716 9310
FAX: (886) 2 2715 3029