



## Audio Processor with BBE

### ■ GENERAL DESCRIPTION

**NJW1146A** is an audio processor with BBE, which also includes Master volume, Balance, Tone Control, eala(NJRC surround), Mute, and Output filter amplifier. All of internal status and variables are controlled by I<sup>2</sup>C BUS.

### ■ FEATURES

- Operating Voltage 8 to 13 V
- I<sup>2</sup>C Bus interface
- BBE 0 to +15dB(0.5dB/step)
- eala & simulated stereo
- Master Volume 0 to -80dB, MUTE(0.33dB/step)
- Balance 0 to -30dB, MUTE(1dB/step)
- Tone Control -15 to +15dB(0.5dB/step)
- Bi-CMOS
- Package Outline SSOP32

### ■ PACKAGE OUTLINE



**NJW1146AV**

### ■ BLOCK DIAGRAM

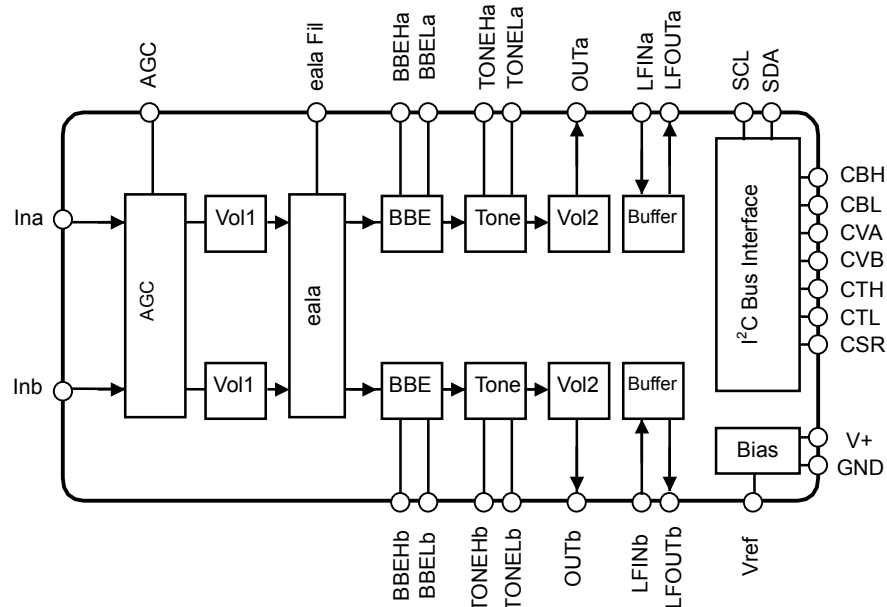

# NJW1146A

## ■ PIN FUNCTION

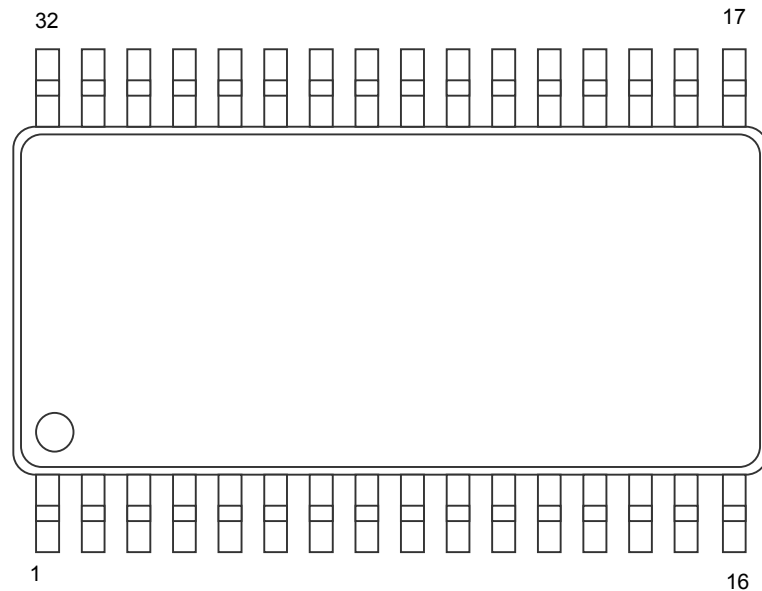

No.	SYMBOL	FUNCTION	No.	SYMBOL	FUNCTION
1	INa	A ch Input	17	N.C.	No Connect
2	ealaFil	eala Filter Capacitor	18	V+	Power Supply
3	BBE1a	Ach BBE High-Pass Filter Capacitor	19	VREF	Reference Voltage stabilizing Capacitor
4	BBE2a	Ach BBE Low-Pass Filter Capacitor	20	CTL	Tone Control Bass switching noise rejection Capacitor
5	TONE-Ha	Ach TONE Treble Filter Capacitor	21	CTH	Tone Control Treble switching noise rejection Capacitor
6	TONE-La	Ach TONE Bass Filter Capacitor	22	CBL	BBE Low switching noise rejection Capacitor
7	OUTa	Ach Output	23	CBH	BBE High switching noise rejection Capacitor
8	LFINa	Buffer Input for Ach Low Pass Filter	24	LFOUTb	Buffer Output for Bch Low Pass Filter
9	LFOUta	Buffer Output for Ach Low Pass Filter	25	LFINb	Buffer Input for Bch Low Pass Filter
10	AGC	AGC Smoothing Filter Capacitor	26	OUTb	Bch Output
11	CVA	Ach Volume switching noise rejection Capacitor	27	TONE-Lb	Bch TONE Bass Filter Capacitor
12	CVB	Bch Volume switching noise rejection Capacitor	28	TONE-Hb	Bch TONE Treble Filter Capacitor
13	SDA	I <sup>2</sup> C Data Input	29	BBE2b	Bch BBE Low-Pass Filter Capacitor
14	SCL	I <sup>2</sup> C Clock Input	30	BBE1b	Bch BBE High-Pass Filter Capacitor
15	GND	Ground	31	CSR	eala switching noise rejection Capacitor
16	N.C.	No Connect	32	INb	B ch Input

## ■ ABSOLUTE MAXIMUM RATING (Ta=25°C)

PARAMETER	SYMBOL	RATING	UNIT
Supply Voltage	V <sup>+</sup>	15	V
Power Dissipation	P <sub>D</sub>	800 <small>NOTE: EIA/JEDEC STANDARD Test board (76.2x114.3x1.6mm, 2layer, FR-4) mounting</small>	mW
Operating Temperature Range	Topr	-20 to +75	°C
Storage Temperature Range	Tstg	-40 to +125	°C

## ■ ELECTRICAL CHARACTERISTICS (Ta=25°C, V<sup>+</sup>=9V, R<sub>L</sub>=47kΩ, Vin=100mVrms/1kHz MODE ; VOL=0dB, BAL=0dB, AGC=OFF, BBE=OFF, Tone=0dB, eala=By-Pass)

PARAMETER	SYMBOL	TEST CONDITION	MIN.	TYP.	MAX.	UNIT
Operating Voltage	V <sup>+</sup>		8.0	9.0	13.0	V
Supply Current	I <sub>CC</sub>	No Signal	-	25	35	mA
Reference Voltage	V <sub>REF</sub>	No Signal	4.0	4.5	5.0	V
Maximum Input Voltage	V <sub>IM</sub>	VOL=-20dB, THD=10%	2.8	3.0	-	Vrms
Maximum Output Voltage	V <sub>OM</sub>	OUTPUT VOL=0dB, THD=1%	-	2.5	-	Vrms
Channel Balance	G <sub>CB</sub>	VOL=0dB	-1.5	0.0	1.5	dB
Balance Boost A	G <sub>BBA</sub>	CHS="0", BAL=Mute	-2.0	0.0	2.0	dB
Balance Cut A	G <sub>BCA</sub>	CHS="1", BAL=Mute Vin = 1Vrms	-	-	-70	dB
Balance Boost B	G <sub>BBB</sub>	CHS="1", BAL=Mute	-2.0	0.0	2.0	dB
Balance Cut B	G <sub>BCB</sub>	CHS="0", BAL=Mute Vin = 1Vrms	-	-	-70	dB
Total Harmonic Distortion	THD	Vo=0.5Vrms BW=400Hz to 30kHz	-	-	0.5	%
Maximum Voltage Gain	G <sub>VMAX</sub>	VOL= 0dB	-2.0	0.0	2.0	dB
Minimum Voltage Gain	G <sub>VMIN</sub>	VOL= Mute	-	-	-70	dB
Channel Separation	CS	Vin = 1Vrms	-	-	-70	dB
Output Noise 1	V <sub>NO1</sub>	VOL = 0dB BW=400Hz to 30kHz	-	-90 (31.6)	-85 (56.2)	dBV (μVrms)
Output Noise 2	V <sub>NO2</sub>	VOL = Mute BW = 400Hz to 30kHz	-	-106 (5.0)	-96 (15.8)	dBV (μVrms)

BW : Band Width

## ◆ TONE CONTROL CHARACTERISTICS (Ta=25°C, V<sup>+</sup>=9V, R<sub>L</sub>=47kΩ, Vin=100mVrms/1kHz MODE ; VOL=0dB, BAL=0dB, AGC=OFF, BBE=OFF, eala=By-Pass)

PARAMETER	SYMBOL	TEST CONDITION	MIN.	TYP.	MAX.	UNIT
Treble Boost Gain	G <sub>HFBST</sub>	TREB=+15dB, f=10kHz	12.5	15.0	17.5	dB
Treble Boost Flat	G <sub>HFFLT</sub>	TREB=0dB, f=10kHz	-2.0	0.0	2.0	dB
Treble Boost Cut	G <sub>HFCUT</sub>	TRBE=-15dB, f=10kHz	-17.5	-15.0	-12.5	dB
Bass Boost Gain	G <sub>LFBST</sub>	BASS=+15dB, f=100Hz	12.5	15.0	17.5	dB
Bass Boost Flat	G <sub>LFFLT</sub>	BASS=0dB, f=100Hz	-2.0	0.0	2.0	dB
Bass Boost Cut	G <sub>LFcut</sub>	BASS=-15dB, f=100Hz	-17.5	-15.0	-12.5	dB

**◆AGC CHARACTERISTICS** (Ta=25°C, V<sup>+</sup>=9V, R<sub>L</sub>=47kΩ  
MODE ; VOL=0dB, BAL=0dB, AGC=ON, BBE=OFF, Tone=0dB, eala=By-Pass)

PARAMETER	SYMBOL	TEST CONDITION	MIN.	TYP.	MAX.	UNIT
AGC Boost	G <sub>AGCBST</sub>	Vin=50mVrms, f=1kHz	1.5	3.5	5.5	dB
AGC Flat 1	G <sub>AGCFLT1</sub>	Vin=100mVrms, f=1kHz	-2.5	0.0	2.5	dB
AGC Flat 2	G <sub>AGCFLT2</sub>	Vin=150mVrms, f=1kHz	-2.5	0.0	2.5	dB
AGC Flat 3	G <sub>AGCFLT3</sub>	Vin=200mVrms, f=1kHz	-2.5	0.0	2.5	dB
AGC Flat 4	G <sub>AGCFLT4</sub>	Vin=250mVrms, f=1kHz	-2.5	0.0	2.5	dB
AGC Cut	G <sub>AGCCUT</sub>	Vin=2Vrms, f=1kHz	-14	-10	-6.0	dB

**◆BBE CHARACTERISTICS** (Ta=25°C, V<sup>+</sup>=9V, R<sub>L</sub>=47kΩ, Vin=100mVrms/1kHz  
MODE ; VOL=0dB, BAL=0dB, AGC=OFF, Tone=0dB, eala=By-Pass)

PARAMETER	SYMBOL	TEST CONDITION	MIN.	TYP.	MAX.	UNIT
Low Boost Gain	G <sub>BBELOW</sub>	BBE-LOW =+15dB, f=50Hz	12.5	15	17.5	dB
High Boost Gain	G <sub>BBEHIGH</sub>	BBE-HIGH =+15dB, f=10kHz	12.5	15	17.5	dB

**◆eala CHARACTERISTICS** (Ta=25°C, V<sup>+</sup>=9V, R<sub>L</sub>=47kΩ, Vin=100mVrms/1kHz  
MODE ; VOL=0dB, BAL=0dB, AGC=OFF, BBE=0dB, Tone=0dB)

PARAMETER	SYMBOL	TEST CONDITION	MIN.	TYP.	MAX.	UNIT
Simulated Stereo A	G <sub>SIMA</sub>	LIN+RIN→OUTa, f=1KHz, SIM	1.0	3.0	5.0	dB
Simulated Stereo B	G <sub>SIMB</sub>	LIN+RIN→OUTb, f=1KHz, SIM	1.0	3.0	5.0	dB
Surround 3D1	G <sub>3D1</sub>	LIN→OUTa, f=100Hz, SR2	5.5	7.5	9.5	dB
Surround 3D2	G <sub>3D2</sub>	LIN→OUTa, f=10KHz, SR2	-2.0	0.0	2.0	dB
Surround 3D3	G <sub>3D3</sub>	LIN→OUTb, f=100Hz, SR2	0.5	2.5	4.5	dB
Surround 3D4	G <sub>3D4</sub>	LIN→OUTa, f=100Hz, SR1	3.5	5.5	7.5	dB

## ■ I<sup>2</sup>C BUS CHARACTERISTICS (SDA, SCL)

I<sup>2</sup>C BUS Load Conditions: Pull up resistance 4kΩ(Connected to +5V), Load capacitance 200pF (Connected to GND)

PARAMETER	SYMBOL	MIN.	TYP.	MAX.	UNIT
High Level Input Voltage	V <sub>IH</sub>	3.0	-	5.0	V
Low Level Input Voltage	V <sub>IL</sub>	0	-	1.5	V
High Level Input Current	I <sub>IH</sub>	-	-	10	μA
Low Level Input Current	I <sub>IL</sub>	-	-	10	μA
Low Level Output Voltage (3mA at SDA pin)	V <sub>OL</sub>	0	-	0.4	V
Maximum Output Current	I <sub>OL</sub>	-3.0	-	-	mA
Maximum Clock Frequency	f <sub>SCL</sub>	-	-	100	kHz
Data Change Minimum Waiting Time	t <sub>BUF</sub>	4.7	-	-	μs
Data Transfer Start Minimum Waiting Time	t <sub>HD:STA</sub>	4.0	-	-	μs
Low Level Clock Pulse Width	t <sub>LOW</sub>	4.7	-	-	μs
High Level Clock Pulse Width	t <sub>HIGH</sub>	4.0	-	-	μs
Minimum Start Preparation Waiting Time	t <sub>SU:STA</sub>	4.7	-	-	μs
Minimum Data Hold Time	t <sub>HD:DAT</sub>	0	-	3.45	μs
Minimum Data Preparation Time	t <sub>SU:DAT</sub>	250	-	-	ns
Rise Time	t <sub>R</sub>	-	-	1.0	μs
Fall Time	t <sub>F</sub>	-	-	300	ns
Minimum Stop Preparation Waiting Time	t <sub>SU:STO</sub>	4.0	-	-	μs

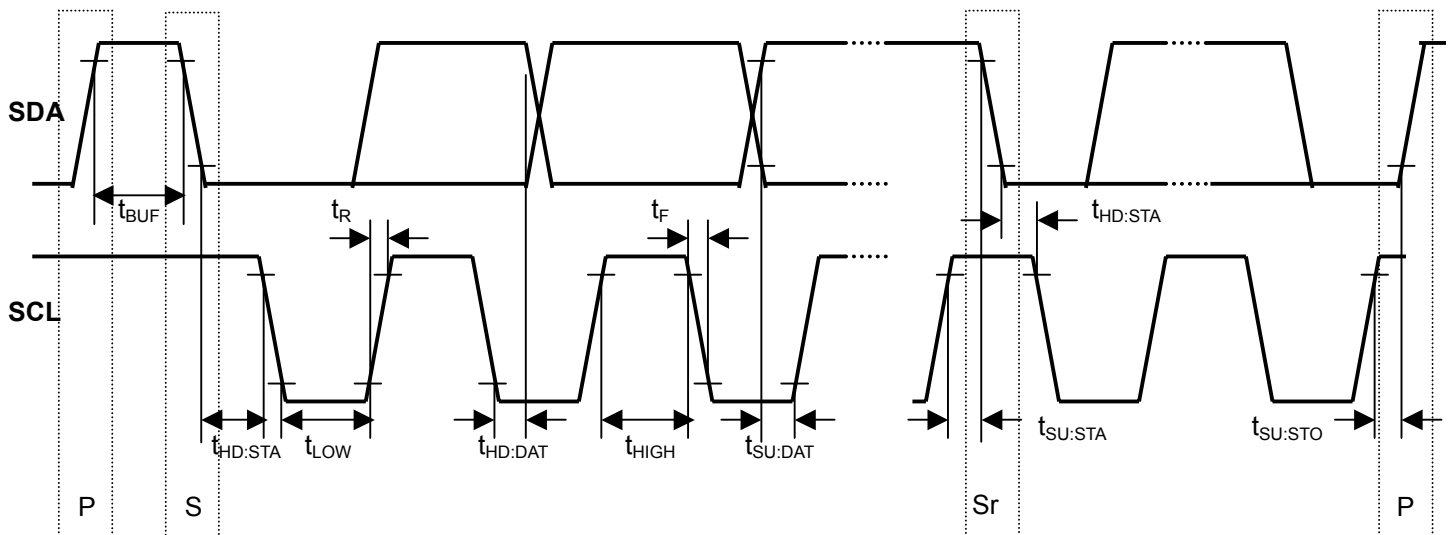

# NJW1146A

## APPLICATION CIRCUIT 1 (Bi-Amp outputs)

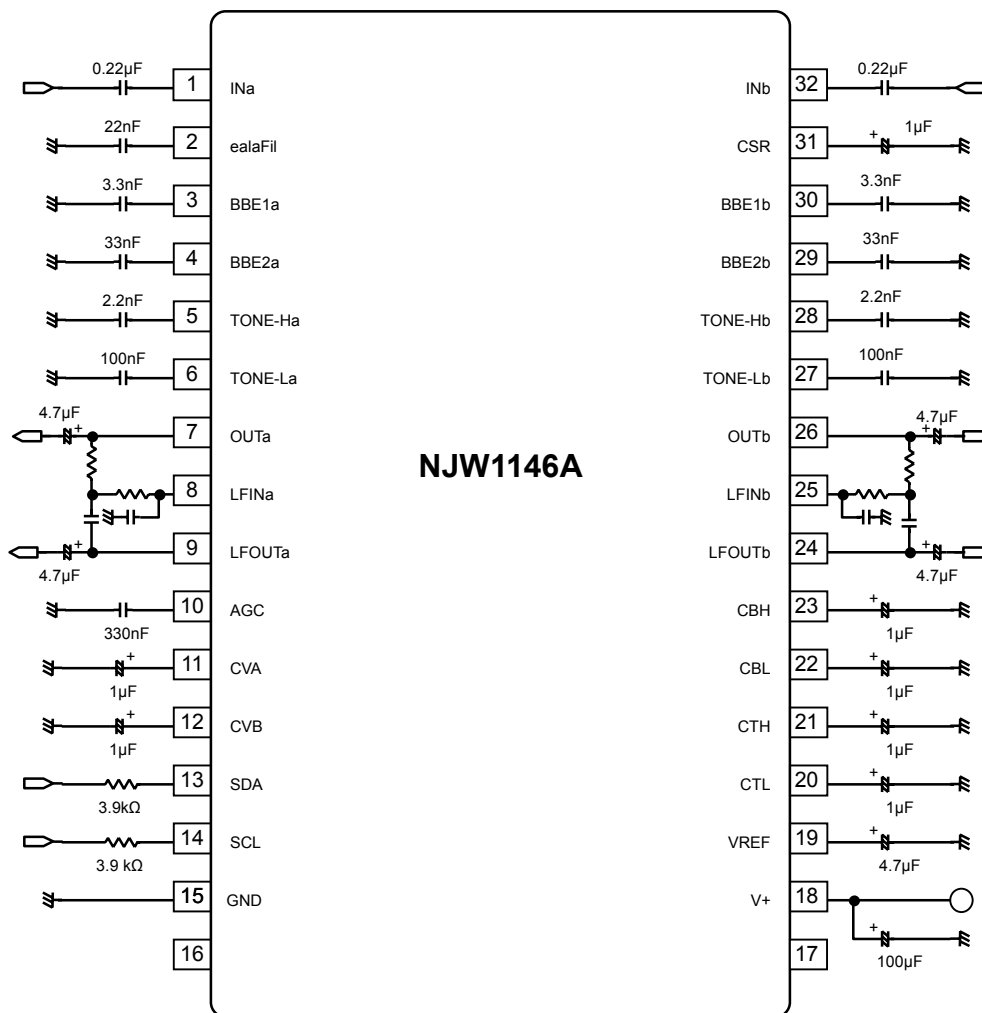

**(NOTE)**

1. Separate the I<sup>2</sup>C bus line from the following terminals for avoiding digital noise problem.

Pin No.	Symbol	Pin No.	Symbol	Pin No.	Symbol	Pin No.	Symbol	Pin No.	Symbol
2	eala Fil	4	BBE2a	6	TONE-La	28	TONE-Hb	30	BBE1b
3	BBE1a	5	TONE-Ha	27	TONE-Lb	29	BBE2b	31	CSR

2. The constant of capacitors connected to the terminals No.3, 4, 29 and 30 are designated by BBE Sound Inc.

## APPLICATION CIRCUIT 2 (Sub-Woofer output)

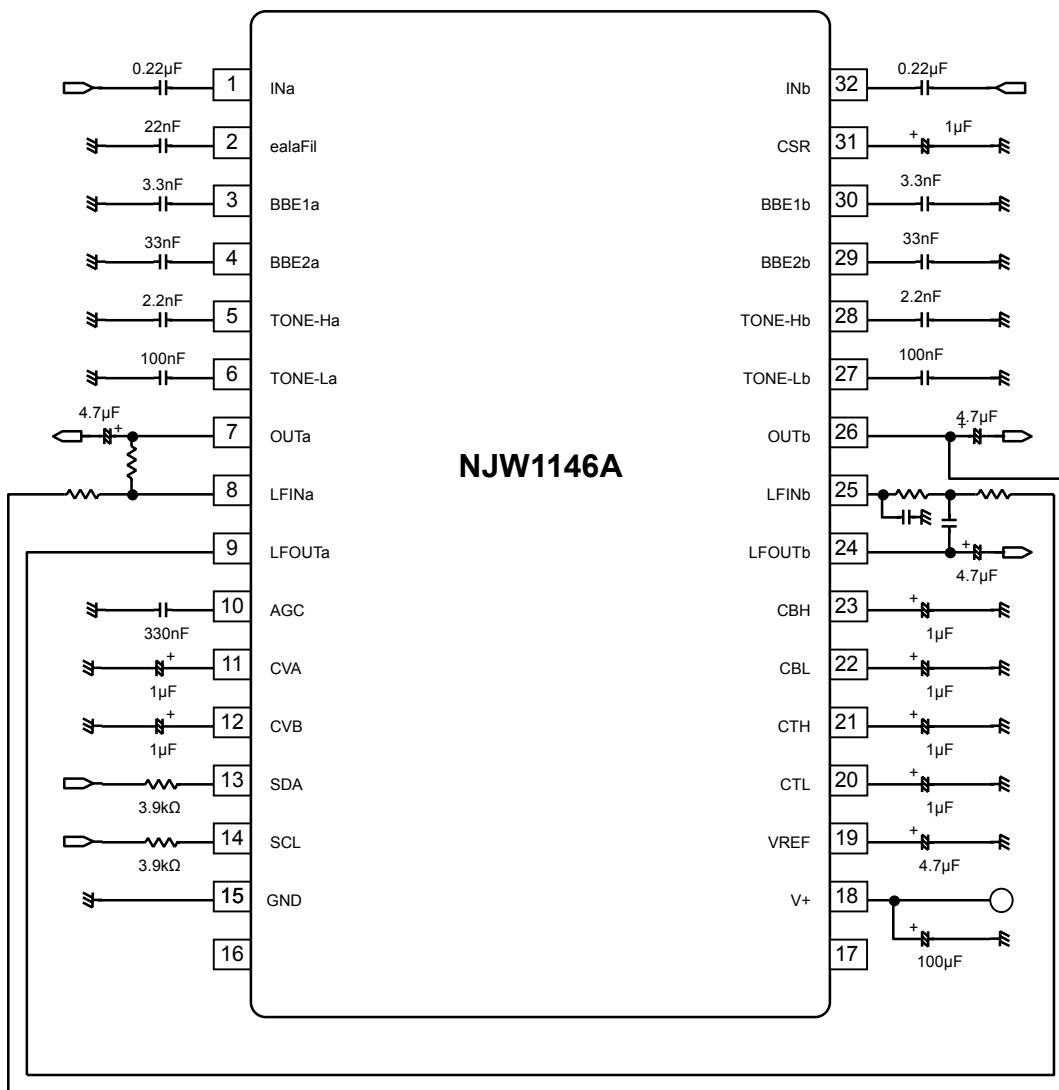

**(NOTE)**

1. Separate the I<sup>2</sup>C bus line from the following terminals for avoiding digital noise problem.

Pin No.	Symbol	Pin No.	Symbol	Pin No.	Symbol	Pin No.	Symbol	Pin No.	Symbol
2	eala Fil	4	BBE2a	6	TONE-La	28	TONE-Hb	30	BBE1b
3	BBE1a	5	TONE-Ha	27	TONE-Lb	29	BBE2b	31	CSR

2. The constant of capacitors connected to the terminals No.3, 4, 29 and 30 are designated by BBE Sound Inc.

## < Output Type >

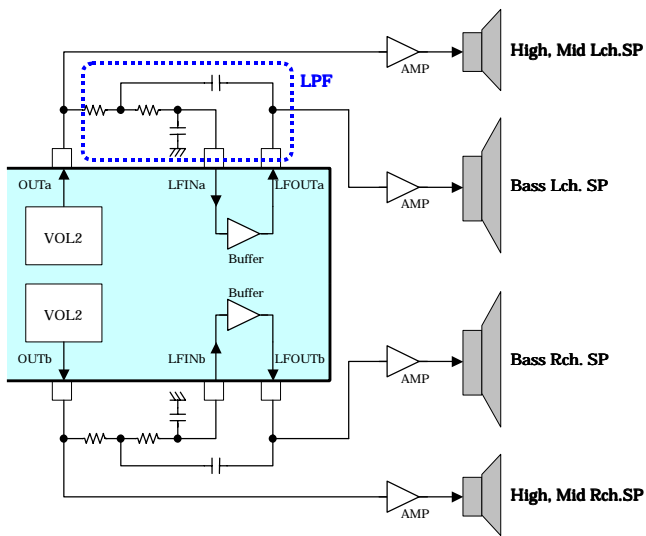

Fig 1. Bi-Amp

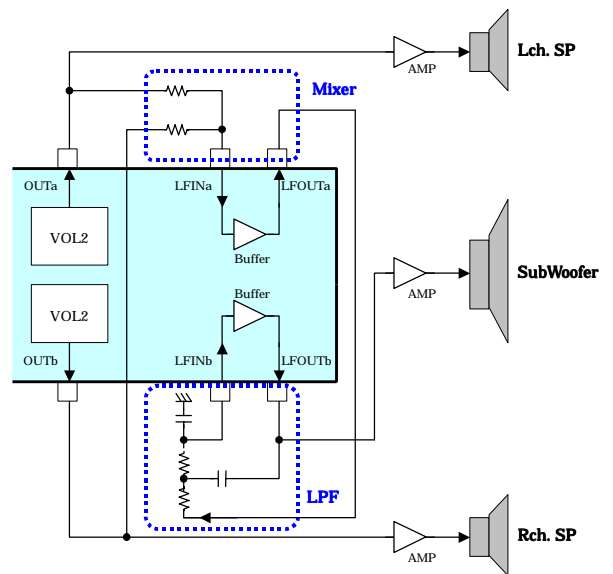
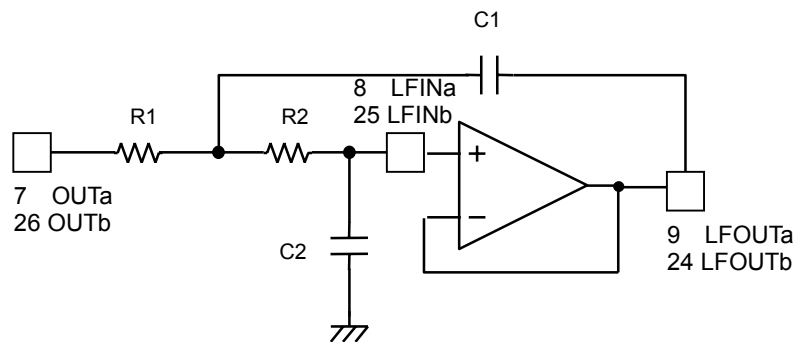

Fig 2. Sub-Woofers

## < OUT, LFIN, LFOUT Low Pass Filter Setting >

LPF cut off frequency and quality factor are adjusted by the external parts and given by the following functions.



$$f_c = \frac{1}{2\pi\sqrt{R1 \cdot R2 \cdot C1 \cdot C2}} \text{ (Hz)}$$

$$Q = \frac{1}{\sqrt{\frac{C2 \cdot R1}{C1 \cdot R2}} + \sqrt{\frac{C1 \cdot R2}{C2 \cdot R1}}}$$



## ■ TERMINAL DESCRIPTION

PIN NO.	SYMBOL	FUNCTION	EQUIVALENT CIRCUIT	TERMINAL VOLTAGE
1 2 8 25 32	INa ealaFil LFINa LFINb INb	A ch Input eala Filter Capacitor Buffer Input for Ach Low Pass Filter Buffer Input for Bch Low Pass Filter B ch Input		V+/2
3 4 29 30	BBE1a BBE2a BBE2b BBE1b	Ach BBE High-Pass Filter Capacitor Ach BBE Low-Pass Filter Capacitor Bch BBE Low-Pass Filter Capacitor Bch BBE High-Pass Filter Capacitor		V+/2
5 28	TONE-Ha TONE-Hb	Ach TONE Treble Filter Capacitor Bch TONE Treble Filter Capacitor		V+/2
6 27	TONE-La TONE-Lb	Ach TONE Bass Filter Capacitor Bch TONE Bass Filter Capacitor		V+/2

## ■ TERMINAL DESCRIPTION

PIN NO.	SYMBOL	FUNCTION	EQUIVALENT CIRCUIT	TERMINAL VOLTAGE
7 9 24 26	OUTa LFOUTa LFOUTb OUTb	Ach Output Buffer Output for Ach Low Pass Filter Buffer Output for Bch Low Pass Filter Bch Output		V+/2
10	AGC	AGC Smoothing Filter Capacitor		-
11 12	CVA CVB	Ach Volume switching noise rejection Capacitor Bch Volume switching noise rejection Capacitor		VREF-0.7V
13 14	SDA SCL	I <sup>2</sup> C Data Input I <sup>2</sup> C Clock Input		-

## ■ TERMINAL DESCRIPTION

PIN NO.	SYMBOL	FUNCTION	EQUIVALENT CIRCUIT	TERMINAL VOLTAGE
15	GND	Ground	-	-
18	V+	Power Supply	-	V+
19	VREF	Reference Voltage Capacitor		V+/2
20	CTL	Tone Control Bass switching noise rejection Capacitor		VREF-0.7V
21	CTH	Tone Control Treble switching noise rejection Capacitor		

# NJW1146A

## ■ TERMINAL DESCRIPTION

PIN NO.	SYMBOL	FUNCTION	EQUIVALENT CIRCUIT	TERMINAL VOLTAGE
22	CBL	BBE Low switching noise rejection Capacitor		VREF-0.7V
23	CBH	BBE High switching noise rejection Capacitor		
31	CSR	eala switching noise rejection Capacitor		0.54V(CSR) 1.4V(CTS2)

## ■ DEFINITION OF I<sup>2</sup>C REGISTER

### ● I<sup>2</sup>C BUS FORMAT



### ● SLAVE ADDRESS



$R\overline{W}=0$ : Receive Only  
 $R\overline{W}=1$ : No Output Data

### ● CONTROL REGISTER TABLE

The select address sets each function (Volume, Balance, Bass Boost Select, AGC, Surround, Tone Control).  
 The auto-increment function cycles the select address as follows.

00H→01H→02H→03H→04H→05H→06H→00H

Select Address	BIT							
	D7	D6	D5	D4	D3	D2	D1	D0
00H	VOL							
01H	CHS	BAL					Don't Care	
02H	BCB	BASS					Don't Care	
03H	BCT	TREB					Don't Care	
04H	BBEL					BBE	Don't Care	
05H	BBEH					AGC	AGC LVL	
06H	eala		Don't Care					

### ● CONTROL REGISTER DEFAULT VALUE

Control register default value is all "0".

Select Address	BIT							
	D7	D6	D5	D4	D3	D2	D1	D0
00H	0	0	0	0	0	0	0	0
01H	0	0	0	0	0	0	0	0
02H	0	0	0	0	0	0	0	0
03H	0	0	0	0	0	0	0	0
04H	0	0	0	0	0	0	0	0
05H	0	0	0	0	0	0	0	0
06H	0	0	0	0	0	0	0	0

## ● CONTROL COMMAND TABLE

### a) Master Volume

Select Address	BIT							
	D7	D6	D5	D4	D3	D2	D1	D0
00H	VOL							

#### ●VOL : Master Volume

Attenuation level : 0 to -80dB(0.33dB/step), MUTE

The volume is consisted of VOL1 and VOL2 and the level is divided into half to each VOL1 and VOL2.

ex) Volume setting is -2dB ; VOL1 and VOL2 is set -1dB each.

### b) Balance

Select Address	BIT							
	D7	D6	D5	D4	D3	D2	D1	D0
01H	CHS	BAL					Don't Care	

#### ●CHS : Balance channel select

"0" : Ach "Bch is attenuated"

"1" : Bch "Ach is attenuated"

#### ●BAL : Ach and Bch Balance

Balance Level : 0 to -30dB (1dB/Step) , MUTE

### c) Tone Control BASS

Select Address	BIT							
	D7	D6	D5	D4	D3	D2	D1	D0
03H	BCB	BASS					Don't Care	

#### ●BCB : Bass Boost or Cut

"0" : Cut

"1" : Boost

#### ●BASS : BASS Level

Cut Level : -15 to 0dB(0.5dB/Step)

Boost Level : 0 to +15dB(0.5dB/Step)

### e) Tone Control TREBLE

Select Address	BIT							
	D7	D6	D5	D4	D3	D2	D1	D0
04H	BCT	TREB					Don't Care	

#### ●BCT : Treble Boost or Cut

"0" : Cut

"1" : Boost

#### ●TREB : Treble Level

Cut Level : -15 to 0dB(0.5dB/Step)

Boost Level : 0 to +15dB(0.5dB/Step)

### f) BBE-Low

Select Address	BIT							
	D7	D6	D5	D4	D3	D2	D1	D0
05H	BBEL					BBE	Don't Care	

#### ● BBEL:BBE-LOW Level

0dB to 15dB (0.5dB/step)

#### ●BBE : BBE ON or OFF

**g) BBE-High**

Select Address	BIT							
	D7	D6	D5	D4	D3	D2	D1	D0
<b>05H</b>	<b>BBEH</b>					<b>AGC</b>	<b>AGC LVL</b>	

●**BBEH: BBE-HIGH Level**

0dB to 15dB (0.5dB/step)

●**AGC : AGC ON or OFF**

●**AGC LVL : AGC Level**

100mVrms, 150mVrms, 200mVrms, 250mVrms

**h) Surround (eala)**

Select Address	BIT							
	D7	D6	D5	D4	D3	D2	D1	D0
<b>06H</b>	<b>eala</b>		<b>Don't Care</b>					

●**eala : eala mode**

Surround effect small (SR1), large (SR2), Simulated Stereo (SIM), By-Pass

# NJW1146A

## ■ Master Volume (Select Address: 00H)

		VOL							
Gain(dB)	HEX	D7	D6	D5	D4	D3	D2	D1	D0
0	FF	1	1	1	1	1	1	1	1
-1	FC	1	1	1	1	1	1	0	0
-2	F9	1	1	1	1	1	0	0	1
-3	F6	1	1	1	1	0	1	1	0
-4	F3	1	1	1	1	0	0	1	1
-5	F0	1	1	1	1	0	0	0	0
-6	ED	1	1	1	0	1	1	0	1
-7	EA	1	1	1	0	1	0	1	0
-8	E7	1	1	1	0	0	1	1	1
-9	E4	1	1	1	0	0	1	0	0
-10	E1	1	1	1	0	0	0	0	1
-11	DE	1	1	0	1	1	1	1	0
-12	DB	1	1	0	1	1	0	1	1
-13	D8	1	1	0	1	1	0	0	0
-14	D5	1	1	0	1	0	1	0	1
-15	D2	1	1	0	1	0	0	1	0
-16	CF	1	1	0	0	1	1	1	1
-17	CC	1	1	0	0	1	1	0	0
-18	C9	1	1	0	0	1	0	0	1
-19	C6	1	1	0	0	0	1	1	0
-20	C3	1	1	0	0	0	0	1	1
-21	C0	1	1	0	0	0	0	0	0
-22	BD	1	0	1	1	1	1	0	1
-23	BA	1	0	1	1	1	0	1	0
-24	B7	1	0	1	1	0	1	1	1
-25	B4	1	0	1	1	0	1	0	0
-26	B1	1	0	1	1	0	0	0	1
-27	AE	1	0	1	0	1	1	1	0
-28	AB	1	0	1	0	1	0	1	1
-29	A8	1	0	1	0	1	0	0	0
-30	A5	1	0	1	0	0	1	0	1
-31	A2	1	0	1	0	0	0	1	0
-32	9F	1	0	0	1	1	1	1	1
-33	9C	1	0	0	1	1	1	0	0
-34	99	1	0	0	1	1	0	0	1
-35	96	1	0	0	1	0	1	1	0
-36	93	1	0	0	1	0	0	1	1
-37	90	1	0	0	1	0	0	0	0
-38	8D	1	0	0	0	1	1	0	1
-39	8A	1	0	0	0	1	0	1	0
-40	87	1	0	0	0	0	1	1	1
-41	84	1	0	0	0	0	1	0	0
-42	81	1	0	0	0	0	0	0	1



		VOL							
Gain(dB)	HEX	D7	D6	D5	D4	D3	D2	D1	D0
-43	7E	0	1	1	1	1	1	1	0
-44	7B	0	1	1	1	1	0	1	1
-45	78	0	1	1	1	1	0	0	0
-46	75	0	1	1	1	0	1	0	1
-47	72	0	1	1	1	0	0	1	0
-48	6F	0	1	1	0	1	1	1	1
-49	6C	0	1	1	0	1	1	0	0
-50	69	0	1	1	0	1	0	0	1
-51	66	0	1	1	0	0	1	1	0
-52	63	0	1	1	0	0	0	1	1
-53	60	0	1	1	0	0	0	0	0
-54	5D	0	1	0	1	1	1	0	1
-55	5A	0	1	0	1	1	0	1	0
-56	57	0	1	0	1	0	1	1	1
-57	54	0	1	0	1	0	1	0	0
-58	51	0	1	0	1	0	0	0	1
-59	4E	0	1	0	0	1	1	1	0
-60	4B	0	1	0	0	1	0	1	1
-61	48	0	1	0	0	1	0	0	0
-62	45	0	1	0	0	0	1	0	1
-63	42	0	1	0	0	0	0	1	0
-64	3F	0	0	1	1	1	1	1	1
-65	3C	0	0	1	1	1	1	0	0
-66	39	0	0	1	1	1	0	0	1
-67	36	0	0	1	1	0	1	1	0
-68	33	0	0	1	1	0	0	1	1
-69	30	0	0	1	1	0	0	0	0
-70	2D	0	0	1	0	1	1	0	1
-71	2A	0	0	1	0	1	0	1	0
-72	27	0	0	1	0	0	1	1	1
-73	24	0	0	1	0	0	1	0	0
-74	21	0	0	1	0	0	0	0	1
-75	1E	0	0	0	1	1	1	1	0
-76	1B	0	0	0	1	1	0	1	1
-77	18	0	0	0	1	1	0	0	0
-78	15	0	0	0	1	0	1	0	1
-79	12	0	0	0	1	0	0	1	0
-80	0F	0	0	0	0	1	1	1	1
Mute	00	0	0	0	0	0	0	0	0

■ Balance (Select Address: 01H)

Channel Setting (CHS)	D7
Attenuated Bch Gain	0
Attenuated Ach Gain	1

Gain(dB)	BAL				
	D6	D5	D4	D3	D2
0	0	0	0	0	0
-1	0	0	0	0	1
-2	0	0	0	1	0
-3	0	0	0	1	1
-4	0	0	1	0	0
-5	0	0	1	0	1
-6	0	0	1	1	0
-7	0	0	1	1	1
-8	0	1	0	0	0
-9	0	1	0	0	1
-10	0	1	0	1	0
-11	0	1	0	1	1
-12	0	1	1	0	0
-13	0	1	1	0	1
-14	0	1	1	1	0
-15	0	1	1	1	1
-16	1	0	0	0	0
-17	1	0	0	0	1
-18	1	0	0	1	0
-19	1	0	0	1	1
-20	1	0	1	0	0
-21	1	0	1	0	1
-22	1	0	1	1	0
-23	1	0	1	1	1
-24	1	1	0	0	0
-25	1	1	0	0	1
-26	1	1	0	1	0
-27	1	1	0	1	1
-28	1	1	1	0	0
-29	1	1	1	0	1
-30	1	1	1	1	0
MUTE	1	1	1	1	1

■ **Tone Control Bass (Select Address: 02H)**

<b>Bass</b>	<b>BCB</b>
<b>Cut or Boost</b>	<b>D7</b>
Cut	0
Boost	1

		<b>BASS</b>				
Cut Gain(dB)	Boost Gain(dB)	D6	D5	D4	D3	D2
-15	15	1	1	1	1	0
-14	14	1	1	1	0	0
-13	13	1	1	0	1	0
-12	12	1	1	0	0	0
-11	11	1	0	1	1	0
-10	10	1	0	1	0	0
-9	9	1	0	0	1	0
-8	8	1	0	0	0	0
-7	7	0	1	1	1	0
-6	6	0	1	1	0	0
-5	5	0	1	0	1	0
-4	4	0	1	0	0	0
-3	3	0	0	1	1	0
-2	2	0	0	1	0	0
-1	1	0	0	0	1	0
0	0	0	0	0	0	0

■ **Tone Control Treble (Select Address: 03H)**

<b>Treble</b>	<b>BCT</b>
<b>Cut or Boost</b>	<b>D7</b>
Cut	0
Boost	1

		<b>TREB</b>				
Cut Gain(dB)	Boost Gain(dB)	D6	D5	D4	D3	D2
-15	15	1	1	1	1	0
-14	14	1	1	1	0	0
-13	13	1	1	0	1	0
-12	12	1	1	0	0	0
-11	11	1	0	1	1	0
-10	10	1	0	1	0	0
-9	9	1	0	0	1	0
-8	8	1	0	0	0	0
-7	7	0	1	1	1	0
-6	6	0	1	1	0	0
-5	5	0	1	0	1	0
-4	4	0	1	0	0	0
-3	3	0	0	1	1	0
-2	2	0	0	1	0	0
-1	1	0	0	0	1	0
0	0	0	0	0	0	0

■ BBE-LOW Gain Code (Select Address: 04H)

Gain(dB)	BBEL				
	D7	D6	D5	D4	D3
15	1	1	1	1	0
14	1	1	1	0	0
13	1	1	0	1	0
12	1	1	0	0	0
11	1	0	1	1	0
10	1	0	1	0	0
9	1	0	0	1	0
8	1	0	0	0	0
7	0	1	1	1	0
6	0	1	1	0	0
5	0	1	0	1	0
4	0	1	0	0	0
3	0	0	1	1	0
2	0	0	1	0	0
1	0	0	0	1	0
0	0	0	0	0	0

■ BBE (Select Address: 04H)

BBE ON/OFF	BBE
	D2
OFF	0
ON	1

■ BBE-HIGH Gain Code (Select Address: 05H)

Gain(dB)	BBEH				
	D7	D6	D5	D4	D3
15	1	1	1	1	0
14	1	1	1	0	0
13	1	1	0	1	0
12	1	1	0	0	0
11	1	0	1	1	0
10	1	0	1	0	0
9	1	0	0	1	0
8	1	0	0	0	0
7	0	1	1	1	0
6	0	1	1	0	0
5	0	1	0	1	0
4	0	1	0	0	0
3	0	0	1	1	0
2	0	0	1	0	0
1	0	0	0	1	0
0	0	0	0	0	0

■ AGC (Select Address: 05H)

AGC ON/OFF	AGC
	D2
OFF	0
ON	1

■ AGC Level (Select Address: 05H)

AGC Level	AGC LVL	
	D1	D0
100mVrms	0	0
150mVrms	0	1
200mVrms	1	0
250mVrms	1	1

■ eala mode (Select Address: 06H)

eala MODE	eala	
	D7	D6
By-Pass	0	0
Simulated Stereo (SIM)	0	1
3D Effect Large (SR2)	1	0
3D Effect Small (SR1)	1	1

## ■NOTE

The **NJW1146A** is manufactured by New Japan Radio Co., Ltd. under license from BBE Sound Inc. BBE is a registered trademark of BBE Sound Inc. A license from BBE Sound Inc. is required before the **NJW1146A** can be purchased from New Japan Radio Co.,Ltd.

BBE Sound, Inc.  
5381 Production Drive  
Huntington Beach, CA 92649  
Tel:(714) 897-6766  
Fax:(714) 896-0736

[CAUTION]  
The specifications on this data book are only given for information, without any guarantee as regards either mistakes or omissions. The application circuits in this data book are described only to show representative usages of the product and not intended for the guarantee or permission of any right including the industrial rights.