

4-ch BTL Motor Driver for CD Players

Monolithic IC MM1469

Outline

This IC is a 4-ch BTL driver developed for driving CD player motors and actuators.

With built-in 3.3V (MM1469PH) or 5.0V (MM1469XH) regulator and general-purpose op amp, it supports a variety of applications.

Features

- (1) External resistor allows gain adjustment.
- (2) Few external parts.
- (3) Built-in 3.3V or 5.0V regulator. (Requires external PNP Tr.)
- (4) Built-in general-purpose op amp.
- (5) Built-in thermal shutdown circuit.

Package

HSOP-28

Applications

- (1) CD radio cassette recorder
- (2) VCD

Block diagram (MM1469XH)

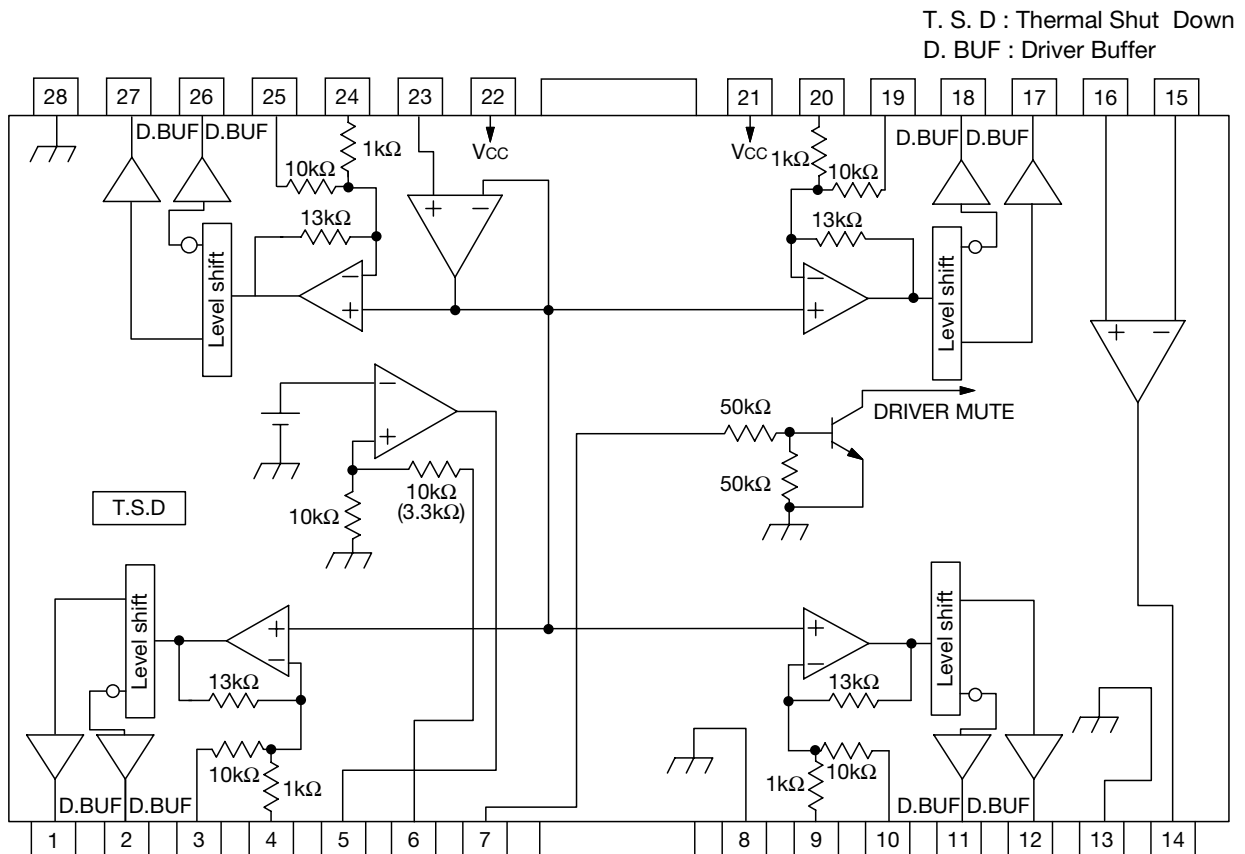

note Constane in parenehesis is regulator output voltage 3.3V(MM1469PH).

Pin configuration

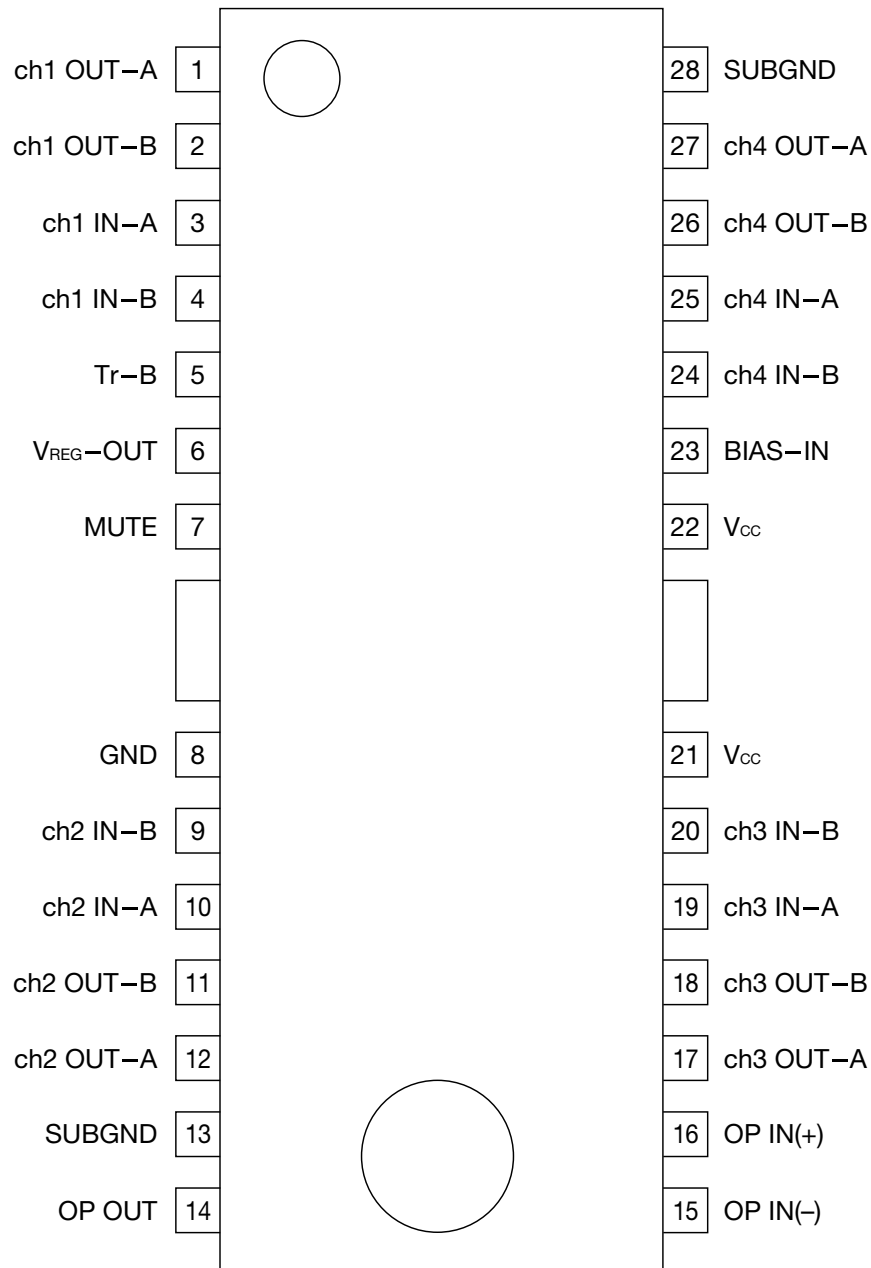

1	ch1 OUT-A	15	OP IN(-)
2	ch1 OUT-B	16	OP IN(+)
3	ch1 IN-A	17	ch3 OUT-A
4	ch1 IN-B	18	ch3 OUT-B
5	Tr-B	19	ch3 IN-A
6	V _{REG} -OUT	20	ch3 IN-B
7	MUTE	21	V _{CC}
8	GND	22	V _{CC}
9	ch2 IN-B	23	BIAS-IN
10	ch2 IN-A	24	ch4 IN-B
11	ch2 OUT-B	25	ch4 IN-A
12	ch2 OUT-A	26	ch4 OUT-B
13	SUBGND	27	ch4 OUT-A
14	OP OUT	28	SUBGND

Terminal explanations

Pin No.	Pin Name	Function	Internal equivalent circuit
1 12 17 27	ch1-OUT A ch2-OUT A ch3-OUT A ch4-OUT A	Driver ch1 negative output Driver ch2 negative output Driver ch3 negative output Driver ch4 negative output	
2 11 18 26	ch1-OUT B ch2-OUT B ch3-OUT B ch4-OUT B	Driver ch1 positive output Driver ch2 positive output Driver ch3 positive output Driver ch4 positive output	
3 10 19 25	ch1-IN A ch2-IN A ch3-IN A ch4-IN A	Driver ch1 input Driver ch2 input Driver ch3 input Driver ch4 input	
4 9 20 24	ch1-IN B ch2-IN B ch3-IN B ch4-IN B	Driver ch1 input, gain adjustment pin Driver ch2 input, gain adjustment pin Driver ch3 input, gain adjustment pin Driver ch4 input, gain adjustment pin	
5	Tr-B	Connect to external transistor base	
6	V _{REG} -OUT	Constant voltage output, connects to external transistor collector	

Terminal Explanations

Pin No.	Pin Name	Function	Internal equivalent circuit
7	MUTE	Driver mute control input	
8	GND	GND	
13 28	Substrate GND	Substrate GND	
14	OP-OUT	Operational amplifier output	
15 16	OP-IN(-) OP-IN(+)	Operational amplifier negative input Operational amplifier positive input	
21 22	Vcc	Vcc	
23	BIAS-IN	Bias amplifier input	

Absolute Maximam Ratings (Ta=25°C)

Item	Symbol	Rating	Unit
Storage temperature	T _{STG}	-55 ~ +150	°C
Supply voltage	V _{CC} max.	13.5	V
Power dissipations	P _d	1.7 *1	W

*1 Use base condition:100x100mm, t=1.6mm, copper leaf 50%, glass epoxy mounting.
Derating is done at 13.6mW/°C for operation above Ta=25°C

Recommended Operating Conditions

Item	Symbol	Rating	Unit
Operating temperature	T _{OPR}	-35 ~ +85	°C
Operational voltage	V _{OPR}	2.0 ~ 9.0 *2	V

*2 Driver section can operate as low as 5.5V.

Electrical Characteristics (V_{CC}=8V, Ta=25°C, f=1kHz, unless otherwise specified)

Item	Symbol	Test Conditions	Min.	Typ.	Max.	Unit
Quiescent current	I _{CC}	No load	5.5	8.0	10.5	mA
Output voltage offset	V _{OO}		-40		40	mV
Output voltage "H"	V _{OHD}		5.2	5.6		V
Output voltage "L"	V _{OLD}			1.3	1.55	V
Gain (Close circuit)	G _{VC}	V _{IN} =0.1V _{rms} , f=1kHz	7.0	8.0	9.0	dB
Ripple rejection	RR	V _{IN} =0.1V _{rms} , f=100Hz		60		dB
Slew rate	SR	V _{OUT} =3V _{p-p} square wave, f=100kHz		2.0		V/μS
Mute-off voltage	V _{MOFF}		2.0			V
5V regulator						
Output voltage	V _{REG}	I _L =100mA	4.75	5.00	5.25	V
Output load variation	ΔV _{RL}	I _L =0 ~ 200mA	-50	0	10	mV
Power supply voltage variation	ΔV _{VCC}	V _{CC} =6 ~ 9V (I _L =100mA)	-10	0	25	mV
Operational Amplifier						
Offset voltage	V _{OFOP}		-2	0	2	mV
Input bias current	I _{BOP}			20	300	nA
"H" level output voltage	V _{OHOP}		6.0			V
"L" level output voltage	V _{OLOP}				1.8	V
Output drive current (sink)	I _{SINK}	50Ω, at V _{CC}	10	50		mA
Output drive current (source)	I _{SOURCE}	50Ω, at ground	10	30		mA
Voltage gain (open circuit)	G _{VO}	V _{IN} =75dBV, f=1kHz		78		dB
Slew rate	SR _{OP}	V _{OUT} =4V _{p-p} square wave, f=100kHz		1		V/μS
Ripple rejection	RR _{OP}	V _{IN} =-20dBV, f=100kHz		65		dB
Common mode rejection ratio	CMRR	V _{IN} =-20dBV, f=1kHz	70	84		dB

Measuring Circuit

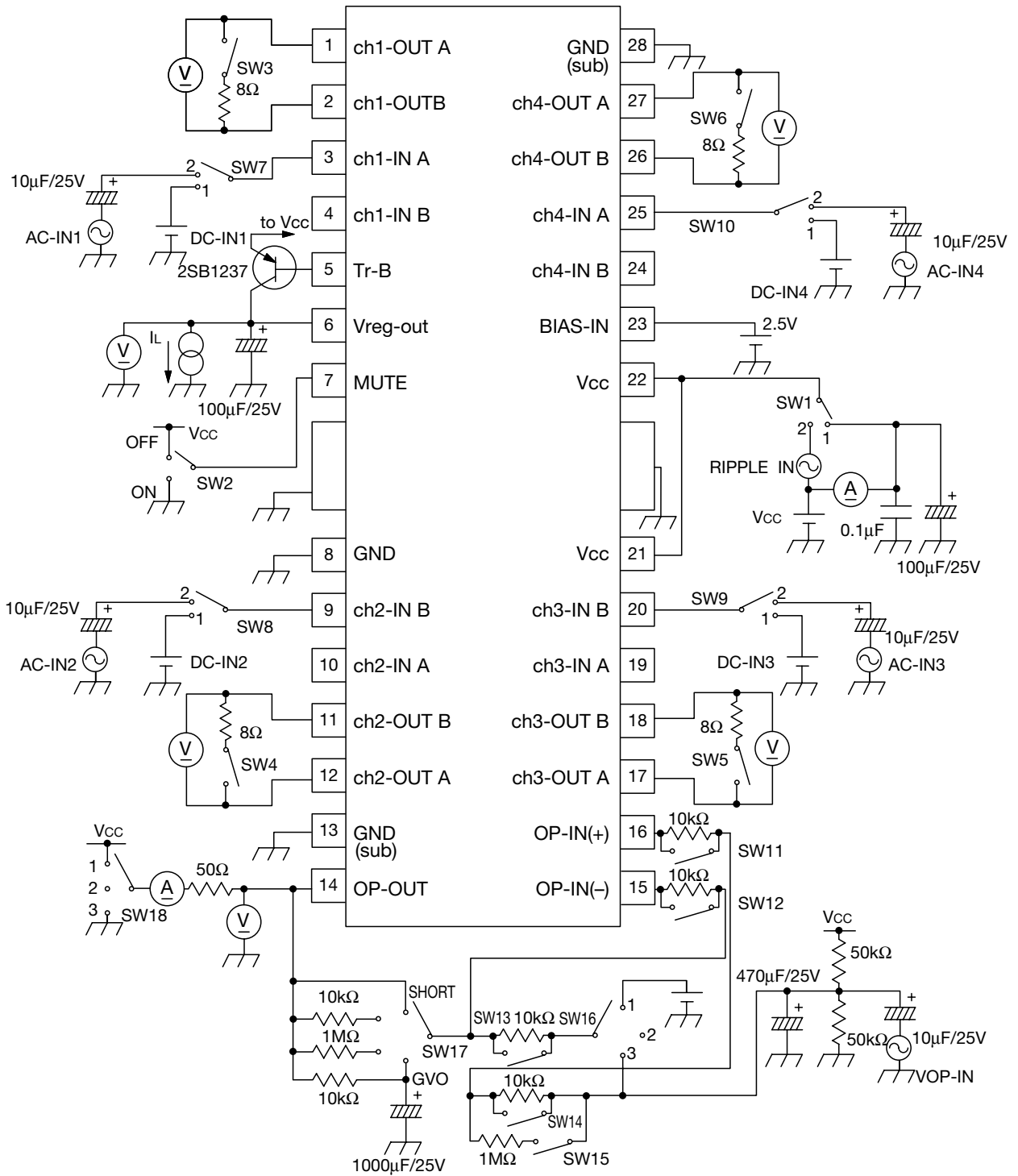

Application Circuit

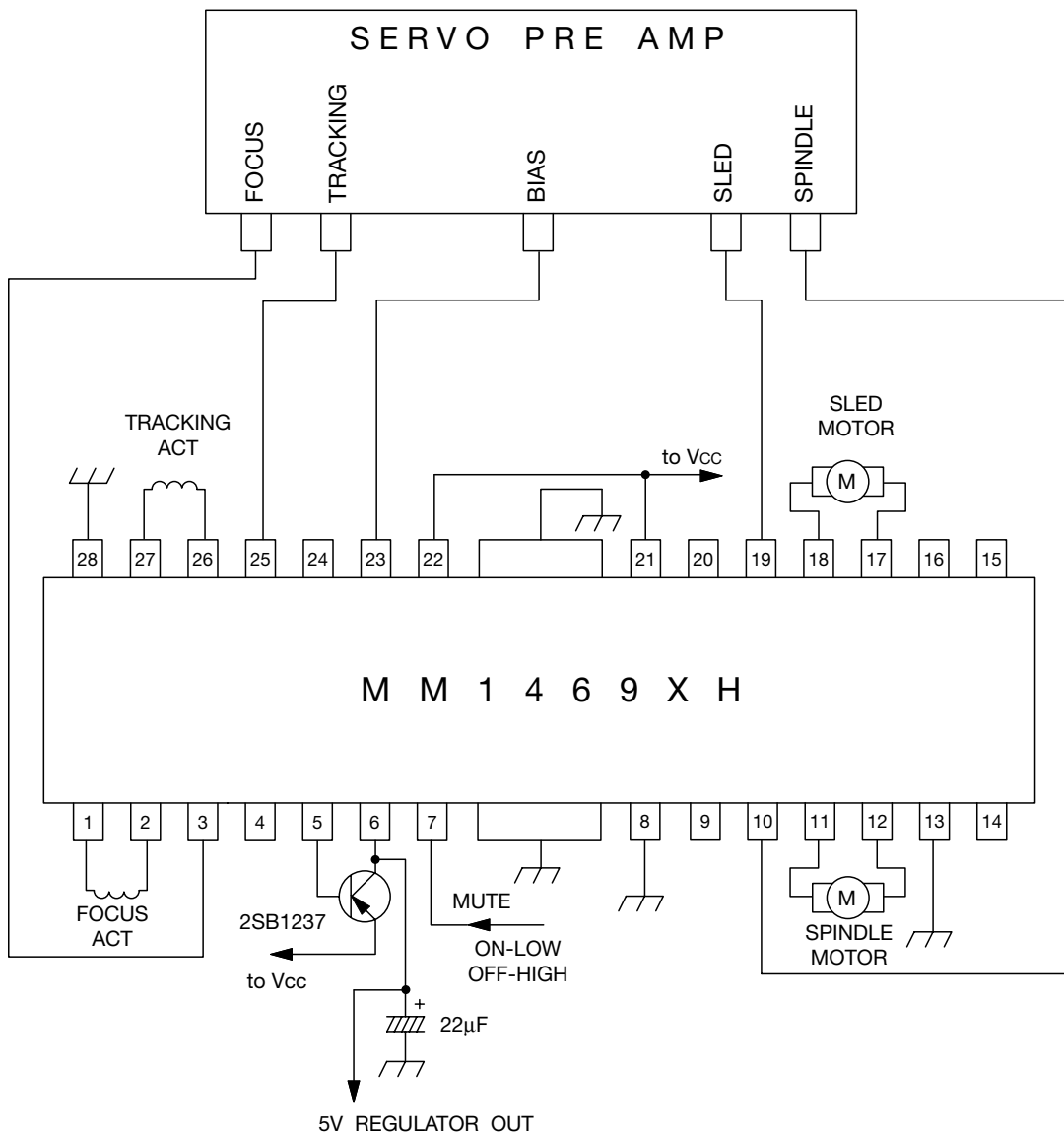

Precautions for use

- (1) A thermal shut down circuit is built. When the temperature of the chip reaches 175°C typ., the output current is muted.
- (2) If the mute (7PIN) voltage is open or is less than 0.5V, the output current is muted. Under normal operating conditions, make sure to pull pin (7PIN) above 2.0V.
- (3) If the bias pin (23PIN) drops below 1.4V, the output current is muted. Make sure that under normal operating conditions, this pin is at 1.6V or above.
- (4) If the power supply voltage drops below 4.5V typ., the drivers are turned OFF. When the voltage exceeds 4.7V typ., the drivers return to their previous state.
- (5) The channel 4 output is muted in the event of a thermal shut down, mute on, bias pin voltage drop. Other sections are not muted. When muted, the internal bias voltage of the output pin becomes (roughly $(V_{CC}-V_F)/2$).
- (6) The built-in input resistance has a positive temperature coefficient of 1500ppm/°C. When changing the gain using an external resistance, the gain will change as the temperature of the resistor changes. When using the built-in input resistance, there are virtually no gain variation due to temperature.
- (7) Make sure to connect a 0.47µF capacitor to the IC input to filter out voltage ripple.
- (8) Heat dissipation fins are attached to the GND on the inside of the package. Make sure to connect these to the external GND.
- (9) The capacitor connected between the regulator output (6PIN) and the GND also serves to stop oscillation of the IC circuit. Consequently, make sure to use one with good temperature characteristics.

Characteristics

Input Voltage – Output Voltage(1) Driver Circuit($R_L=8\Omega$)

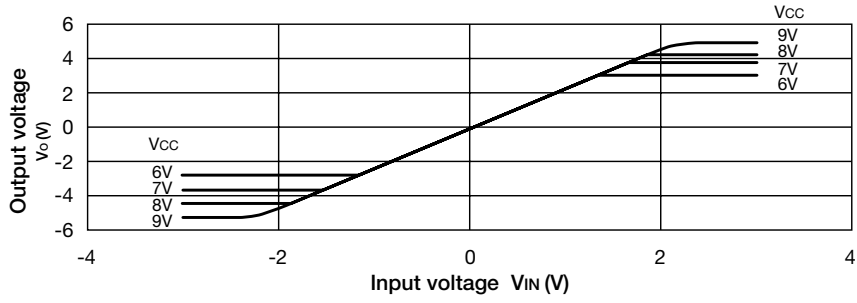

Input Voltage – Output Voltage(2) Driver Circuit($V_{CC}=8V$)

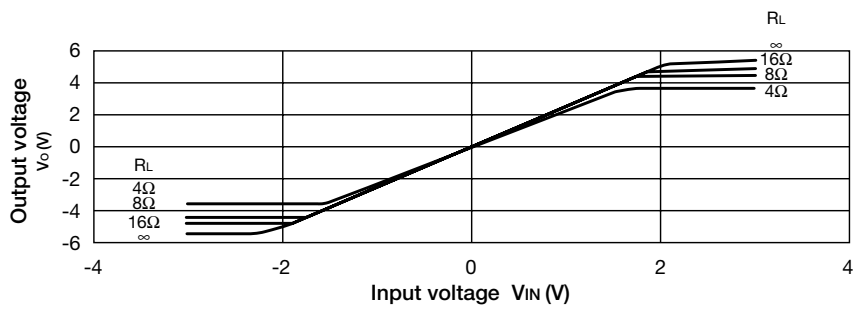

Supply Voltage – Output Offset Voltage Driver Circuit

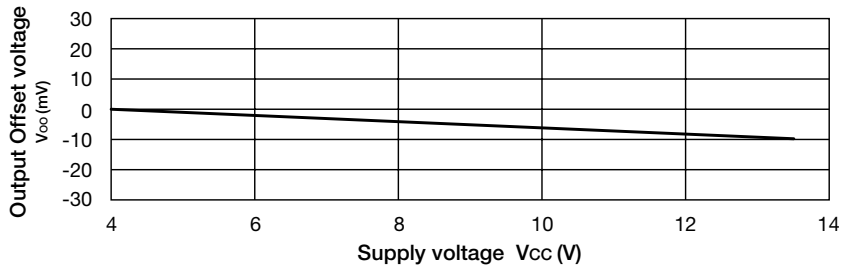

Output Load Variation 5V Regulator

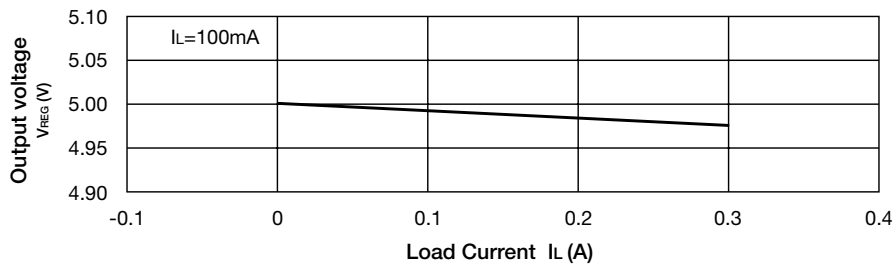

Characteristics

Input Voltage – Output Voltage(1) Driver Circuit

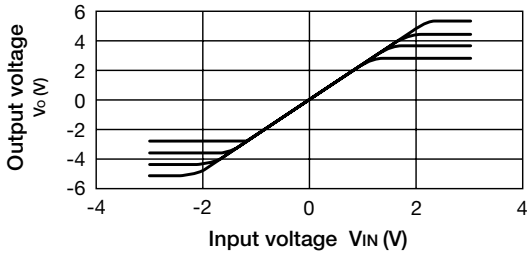

Input Voltage – Output Voltage(2) Driver Circuit

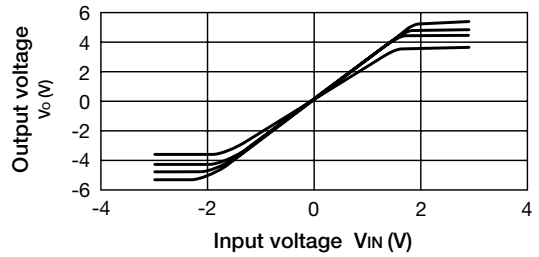

Supply Voltage – Output Offset Voltage Driver Circuit

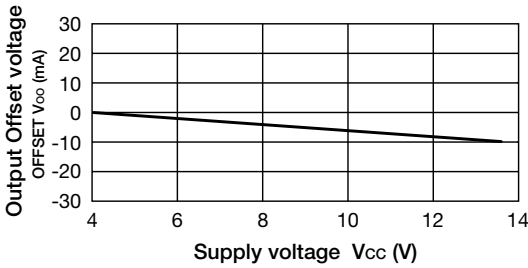

Output Load Variation 5V Regulator

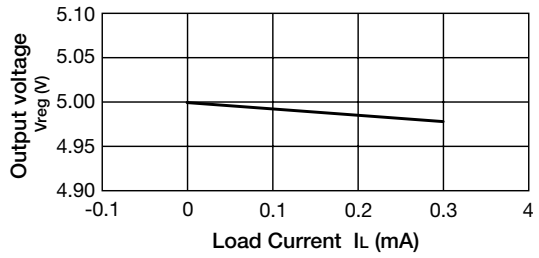

Temperature – Voltage 5V Regulator

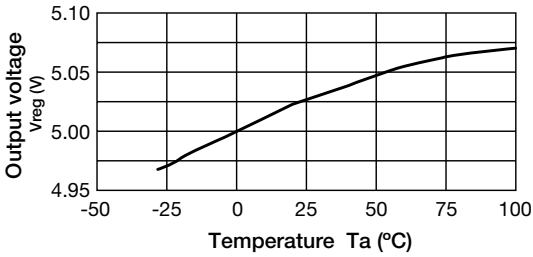

Supply Voltage – Output Voltage Op Amp

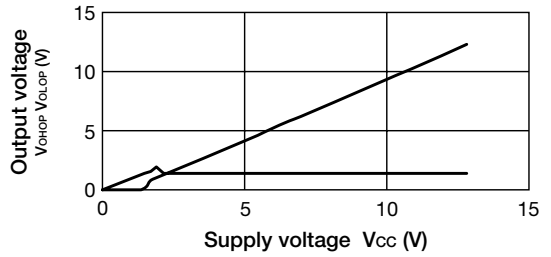

Supply Voltage – Output Current Op Amp

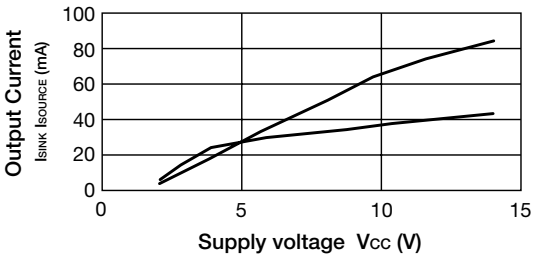

Characteristics

Temperature – Voltage 5V Regulator

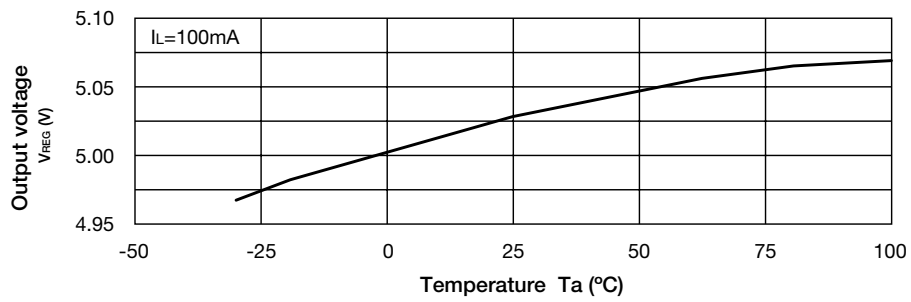

Supply Voltage – Output Voltage Op Amp

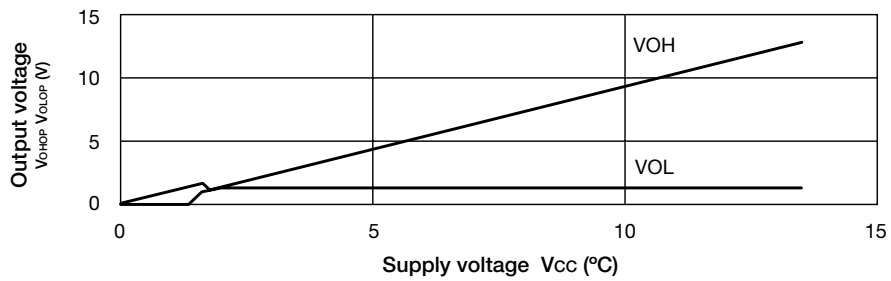

Supply Voltage – Output Current Op Amp

