

# MF1037S-2

FOR PERSONAL HANDYPHONE SYSTEM

MF1037S-2

## DESCRIPTION

This SAW filter for the RF circuit of personal handyphone system.

## FEATURES

1. SMD package insures small size, lightweight.
2. Adjustment free.
3. Low insertion loss and high stop band attenuation.
4. Wide and sharp passband characteristics.
5. High stability and reliability.
6. Designed for reflow solderings.

## APPLICATION

- Portable telephone
- Wireless equipment

## ELECTRICAL PERFORMANCE

Parameter	MF1037S-2			Units
	Min	Typ	Max	
PASSBAND FREQUENCY	1895 – 1918			MHz
PASSBAND CHARACTERISTICS				
Insertion Loss		2.6	3.5	dB
Ripple		0.4	1.5	dBp-p
VSWR		1.5	2.5	
STOPBAND ATTENUATION				
1395 – 1418 MHz	35	55		dB
1645 – 1668 MHz	30	32		dB

## MAXIMUM RATINGS

Rating	Value	Unit
Input Power	40	mW
Operating Temperature Range	-20 to 75	°C
Storage Temperature Range	-30 to 85	°C

## PACKAGE OUTLINE DIMENSIONS

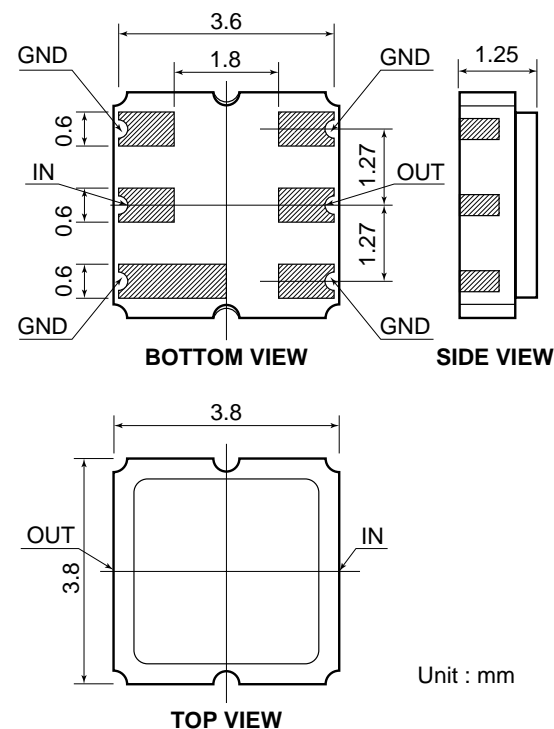

DIMENSIONS ARE IN MILLIMETERS  
±0.2 UNLESS OTHERWISE SPECIFIED

## MF1037S-2 TYPICAL CHARACTERISTICS

