

MF1017S-1

FOR DIGITAL MOBILE TELEPHONE, Rx

MF1017S-1

DESCRIPTION

This SAW filter for the receiving RF circuit of digital mobile communication equipment operating at 810 MHz ~ 830 MHz.

FEATURES

1. SMD package insures small size, lightweight.
2. Adjustment free.
3. Low insertion loss and high stop band attenuation.
4. Wide and sharp passband characteristics.
5. High stability and reliability.
6. Designed for reflow solderings.

APPLICATION

- Mobile Cellular Telephone
- Portable Cellular Telephone
- Wireless equipment

MAXIMUM RATINGS

Rating	Value	Unit
Input Power	100	mW
Operating Temperature Range	-20 to 75	°C
Storage Temperature Range	-30 to 85	°C

ELECTRICAL PERFORMANCE

Parameter	MF1017S-1			Units
	Min	Typ	Max	
PASSBAND FREQUENCY	810 – 830			MHz
PASSBAND CHARACTERISTICS	Insertion Loss	2.5	3.5	dB
	Ripple	0.5	1.5	
	VSWR	1.5	2.5	
STOPBAND ATTENUATION	0 – 620 MHz	30	35	dB
	620 – 760 MHz	20	32	
	880 – 960 MHz	20	30	
	960 – 1500 MHz	30	35	

PACKAGE OUTLINE DIMENSIONS

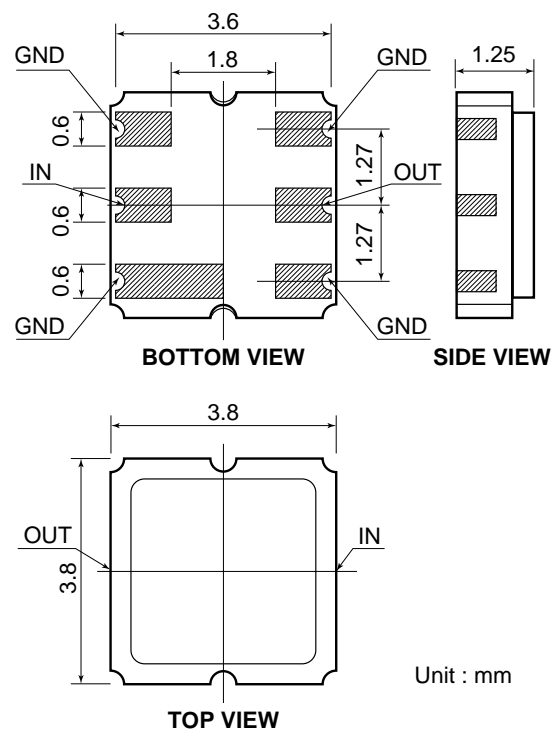

DIMENSIONS ARE IN MILLIMETERS
±0.2 UNLESS OTHERWISE SPECIFIED

MF1017S-1 TYPICAL CHARACTERISTICS

