

# IRG4ZC70UD

INSULATED GATE BIPOLAR TRANSISTOR WITH  
ULTRAFAST SOFT RECOVERY DIODE

Surface Mountable  
UltraFast CoPack IGBT

## Features

- UltraFast IGBT optimized for high switching frequencies
- IGBT co-packaged with HEXFRED™ ultrafast, ultra-soft recovery antiparallel diodes for use in bridge configurations
- Low gate charge
- Low profile low inductance SMD-10 package
- Separated control & Power-connections for easy paralleling
- Inherently coplanar pins and tab
- Easy solder inspection and cleaning

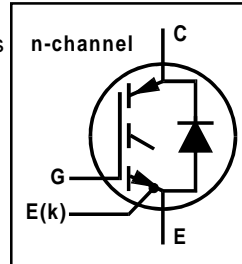

$$V_{CES} = 600V$$

$$V_{CE(ON)typ} = 1.5V$$

$$@V_{GE} = 15V, I_C = 50A$$

## Benefits

- Highest power density and efficiency available
- HEXFRED diodes optimized for performance with IGBTs; Minimized recovery characteristics
- IGBTs optimized for specific application conditions; high input impedance requires low gate drive power
- Low noise and interference

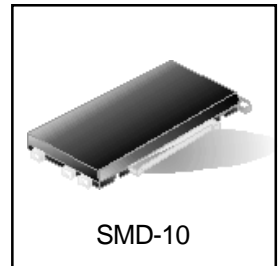

## Absolute Maximum Ratings

	Parameter	Max.	Units
$V_{CES}$	Collector-to-Emitter Breakdown Voltage	600	V
$I_C @ T_C = 25^\circ C$	Continuous Collector Current	100	A
$I_C @ T_C = 100^\circ C$	Continuous Collector Current	50	
$I_{CM}$	Pulsed Collector Current ①	400	
$I_{LM}$	Clamped Inductive Load Current ②	400	
$I_F @ T_C = 100^\circ C$	Diode Continuous Forward Current	50	
$I_{FM}$	Diode Maximum Forward Current	400	
$V_{GE}$	Gate-to-Emitter Voltage	$\pm 20$	V
$P_D @ T_C = 25^\circ C$	Maximum Power Dissipation	350	W
$P_D @ T_C = 100^\circ C$	Maximum Power Dissipation	140	
$T_J$	Operating Junction and	-55 to + 150	$^\circ C$
$T_{STG}$	Storage Temperature Range		

## Thermal Resistance

	Parameter	Min.	Typ.	Max.	Units
$R_{\theta JC}$	Junction-to-Case - IGBT	—	—	0.36	$^\circ C/W$
$R_{\theta JC}$	Junction-to-Case - Diode	—	—	0.69	
$R_{\theta CS}$	SMD-10 Case-to-Heatsink (typical), *	—	0.59	—	
Wt	Weight	—	6.0(0.21)	—	g (oz)

Notes: ① Repetitive rating:  $V_{GE} = 20V$ ; pulse width limited by maximum junction temperature (figure 20)

②  $V_{CC} = 80\%(V_{CES})$ ,  $V_{GE} = 20V$ ,  $L = 10\mu H$ ,  $R_G = 5.0\Omega$  (figure 19)

③ Pulse width  $\leq 80\mu s$ ; duty factor  $\leq 0.1\%$ .

④ Pulse width  $5.0\mu s$ , single shot.

\* Assumes device soldered to 3.0 oz. Cu on 3.0mm IMS/Aluminum board, mounted to flat, greased heatsink.

## Electrical Characteristics @ $T_J = 25^\circ\text{C}$ (unless otherwise specified)

	Parameter	Min.	Typ.	Max.	Units	Conditions
$V_{(BR)CES}$	Collector-to-Emitter Breakdown Voltage ③	600	—	—	V	$V_{GE} = 0V, I_C = 250\mu A$
$\Delta V_{(BR)CES}/\Delta T_J$	Temperature Coeff. of Breakdown Voltage	—	0.36	—	V/°C	$V_{GE} = 0V, I_C = 1.0mA$
$V_{CE(on)}$	Collector-to-Emitter Saturation Voltage	—	1.49	1.9	V	$I_C = 50A$ $V_{GE} = 15V$ see figure 2, 5
		—	1.80	—		
		—	1.47	—		
$V_{GE(th)}$	Gate Threshold Voltage	3.0	—	6.0		$V_{CE} = V_{GE}, I_C = 250\mu A$
$\Delta V_{GE(th)}/\Delta T_J$	Temperature Coeff. of Threshold Voltage	—	-7.6	—	mV/°C	$V_{CE} = V_{GE}, I_C = 250\mu A$
$g_{fe}$	Forward Transconductance ④	34	52	—	S	$V_{CE} = 100V, I_C = 50A$
$I_{CES}$	Zero Gate Voltage Collector Current	—	—	250	$\mu A$	$V_{GE} = 0V, V_{CE} = 600V$
		—	—	1.3	mA	$V_{GE} = 0V, V_{CE} = 600V, T_J = 150^\circ\text{C}$
$V_{FM}$	Diode Forward Voltage Drop	—	1.24	1.5	V	$I_C = 50A$ see figure 13
		—	1.16	1.3		
$I_{GES}$	Gate-to-Emitter Leakage Current	—	—	$\pm 100$	nA	$V_{GE} = \pm 20V$

## Switching Characteristics @ $T_J = 25^\circ\text{C}$ (unless otherwise specified)

	Parameter	Min.	Typ.	Max.	Units	Conditions	
$Q_g$	Total Gate Charge (turn-on)	—	430	640	nC	$I_C = 50A$ $V_{CC} = 400V$ see figure 8	
$Q_{ge}$	Gate - Emitter Charge (turn-on)	—	48	72			
$Q_{gc}$	Gate - Collector Charge (turn-on)	—	130	190			
$t_{d(on)}$	Turn-On Delay Time	—	71	—	ns	$T_J = 25^\circ\text{C}$ $I_C = 50A, V_{CC} = 480V$ $V_{GE} = 15V, R_G = 5.0\Omega$ Energy losses include "tail" and diode reverse recovery. see figures 9, 10, 18	
$t_r$	Rise Time	—	41	—			
$t_{d(off)}$	Turn-Off Delay Time	—	250	370			
$t_f$	Fall Time	—	110	220			
$E_{on}$	Turn-On Switching Loss	—	1.59	—			
$E_{off}$	Turn-Off Switching Loss	—	1.78	—			
$E_{ts}$	Total Switching Loss	—	3.37	4.7			
$t_{d(on)}$	Turn-On Delay Time	—	68	—	ns	$T_J = 150^\circ\text{C}$ , see figures 11, 18 $I_C = 50A, V_{CC} = 480V$ $V_{GE} = 15V, R_G = 5.0\Omega$ Energy losses include "tail" and diode reverse recovery.	
$t_r$	Rise Time	—	43	—			
$t_{d(off)}$	Turn-Off Delay Time	—	370	—			
$t_f$	Fall Time	—	130	—			
$E_{ts}$	Total Switching Loss	—	4.5	—			
$L_E$	Internal Emitter Inductance	—	2.0	—	nH		
$C_{ies}$	Input Capacitance	—	7400	—	pF	$V_{GE} = 0V$ $V_{CC} = 30V$ see figure 7 $f = 1.0MHz$	
$C_{oes}$	Output Capacitance	—	730	—			
$C_{res}$	Reverse Transfer Capacitance	—	90	—			
$t_{rr}$	Diode Reverse Recovery Time	—	90	140	ns	$T_J = 25^\circ\text{C}$ see figure 14 $T_J = 125^\circ\text{C}$ 14	$I_F = 50A$ $V_R = 200V$ $di/dt = 200A/\mu s$
		—	120	180			
$I_{rr}$	Diode Peak Reverse Recovery Current	—	7.3	11	A	$T_J = 25^\circ\text{C}$ see figure 15 $T_J = 125^\circ\text{C}$ 15	
		—	11	16			
$Q_{rr}$	Diode Reverse Recovery Charge	—	360	550	nC	$T_J = 25^\circ\text{C}$ see figure 16 $T_J = 125^\circ\text{C}$ 16	
		—	780	1200			
$di_{(rec)M}/dt$	Diode Peak Rate of Fall of Recovery During $t_b$	—	370	—	A/ $\mu s$	$T_J = 25^\circ\text{C}$ see figure 17 $T_J = 125^\circ\text{C}$ 17	
		—	220	—			

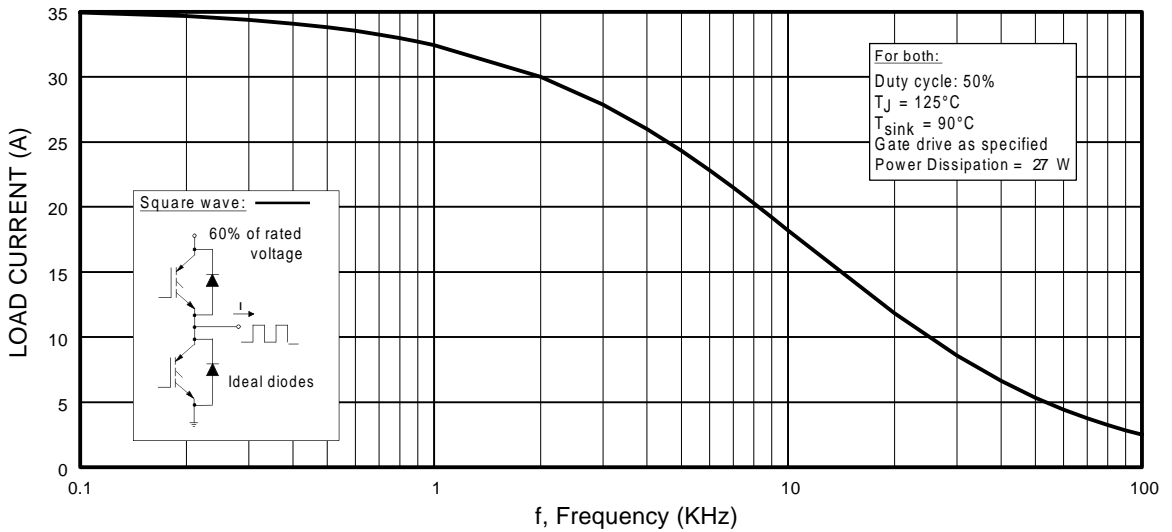

**Fig. 1 - Typical Load Current vs. Frequency**  
 (Load Current =  $I_{\text{RMS}}$  of fundamental)

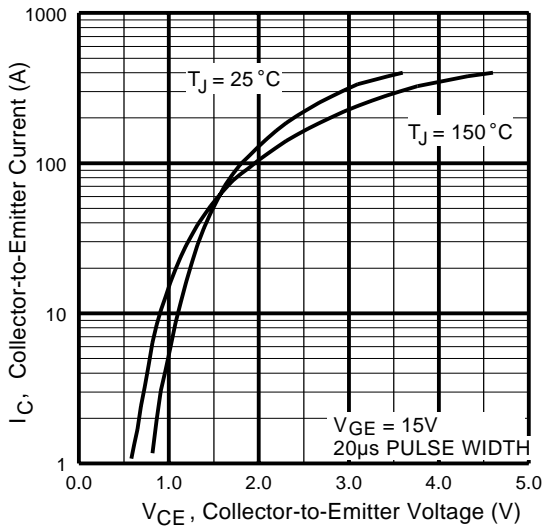

**Fig. 2 - Typical Output Characteristics**

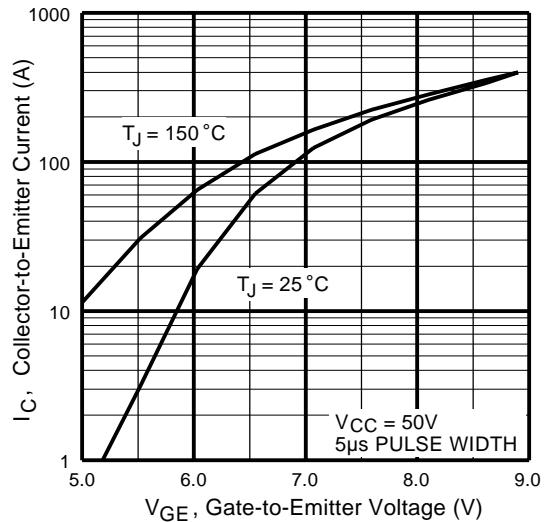

**Fig. 3 - Typical Transfer Characteristics**

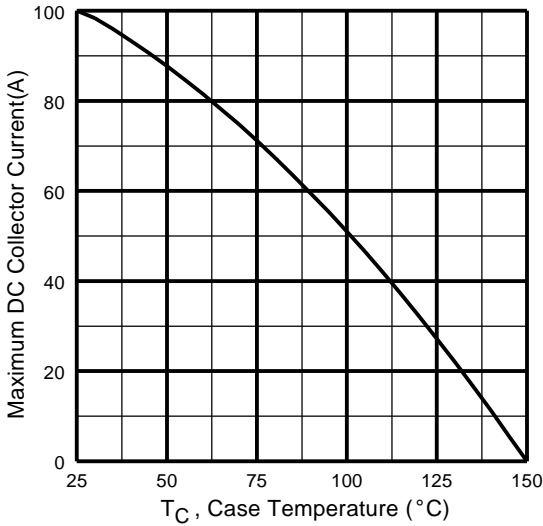

Fig. 4 - Maximum Collector Current vs. Case Temperature

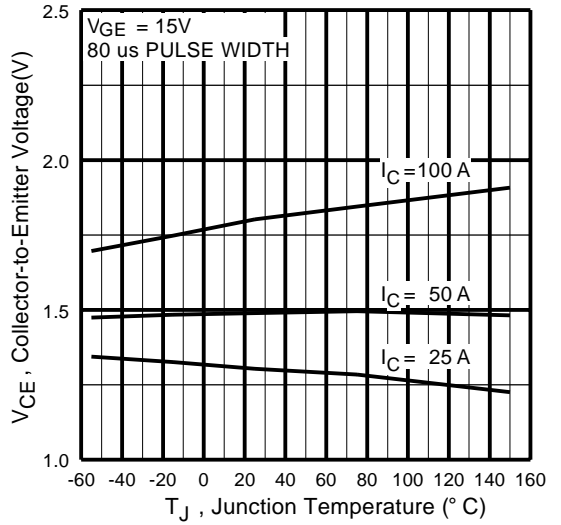

Fig. 5 - Typical Collector-to-Emitter Voltage vs. Junction Temperature

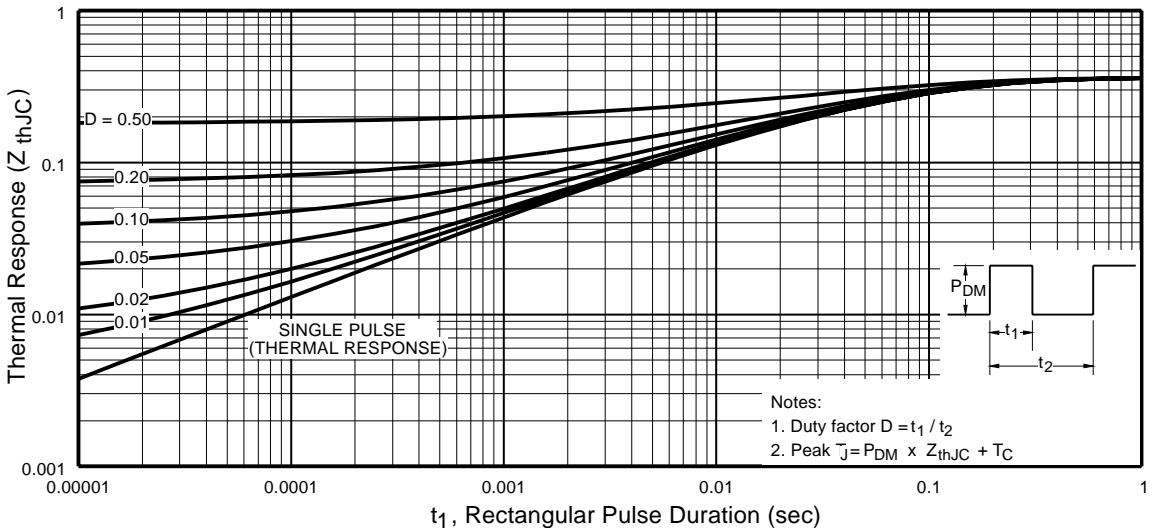
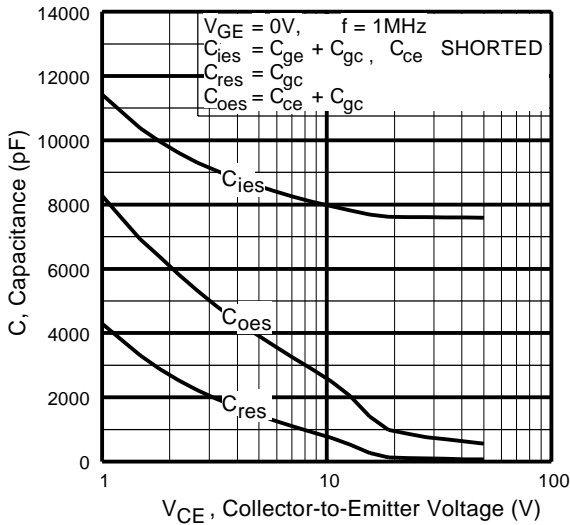
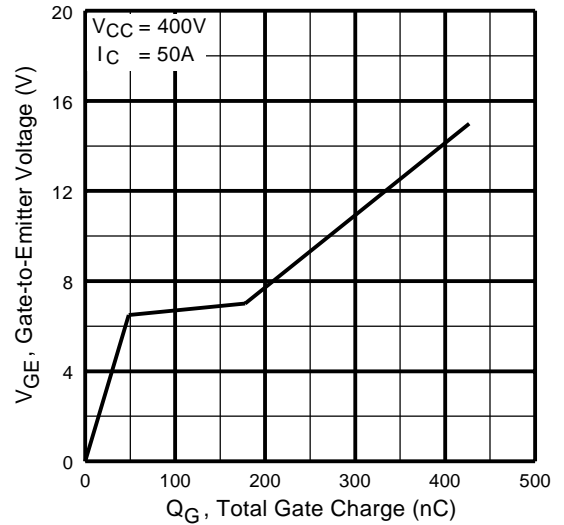

Fig. 6 - Maximum Effective Transient Thermal Impedance, Junction-to-Case



**Fig. 7 - Typical Capacitance vs. Collector-to-Emitter Voltage**



**Fig. 8 - Typical Gate Charge vs. Gate-to-Emitter Voltage**

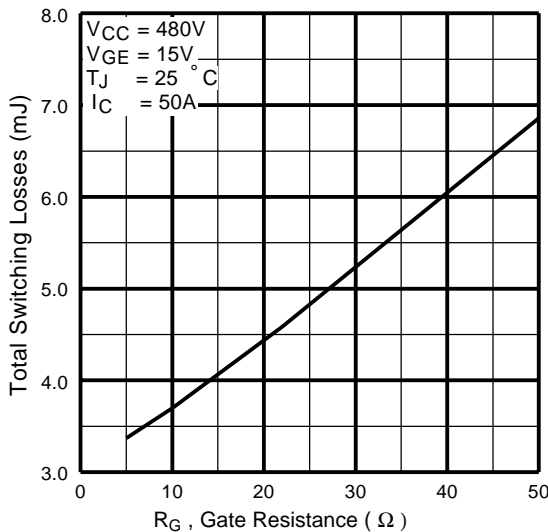

**Fig. 9 - Typical Switching Losses vs. Gate Resistance**

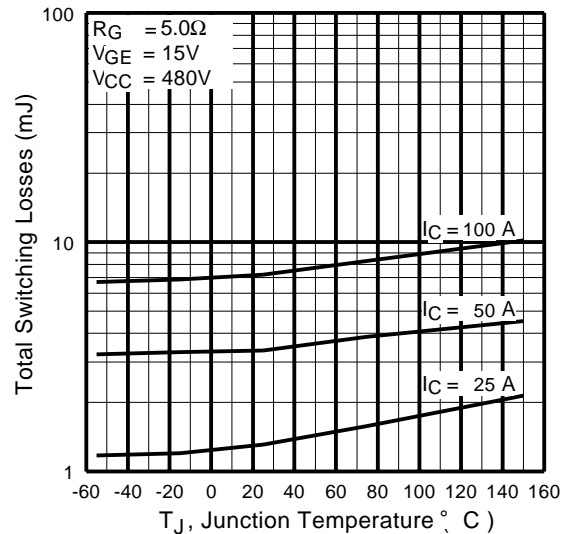

**Fig. 10 - Typical Switching Losses vs. Junction Temperature**

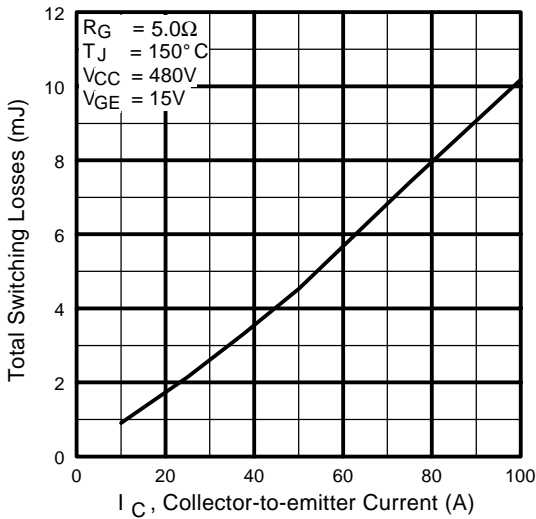

**Fig. 11** - Typical Switching Losses vs. Collector-to-Emitter Current

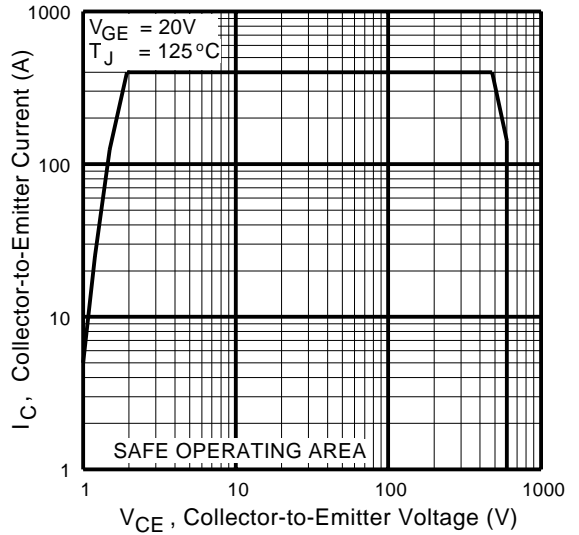

**Fig. 12** - Turn-Off SOA

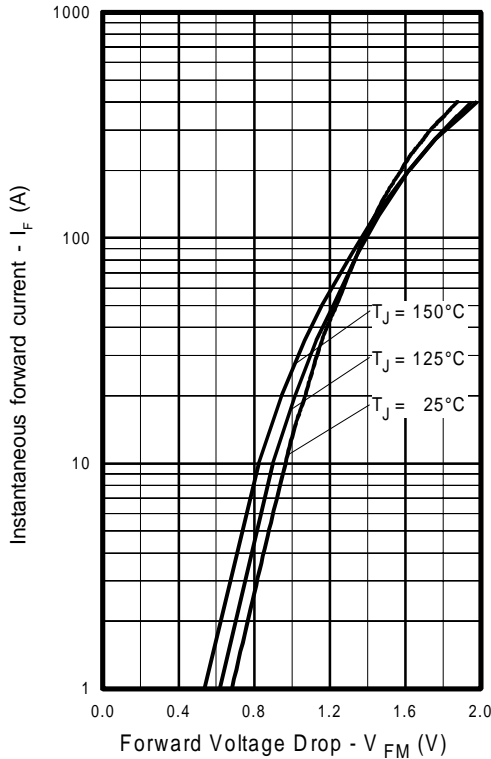

**Fig. 13** - Typical Forward Voltage Drop vs. Instantaneous Forward Current

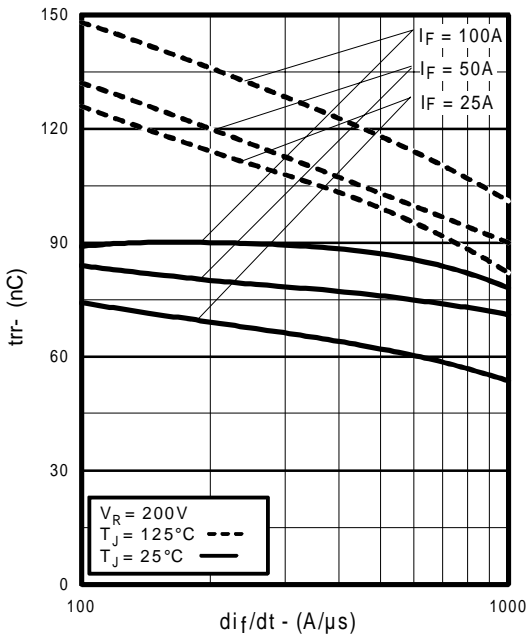

Fig. 14 - Typical Reverse Recovery vs.  $di/dt$

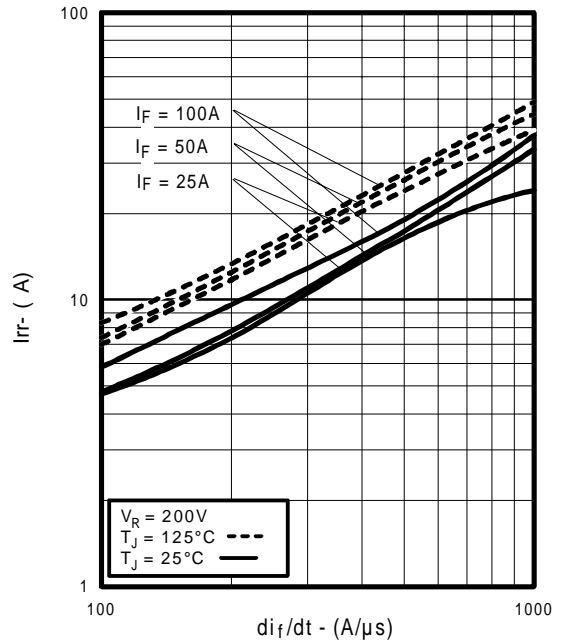

Fig. 15 - Typical Recovery Current vs.  $di/dt$

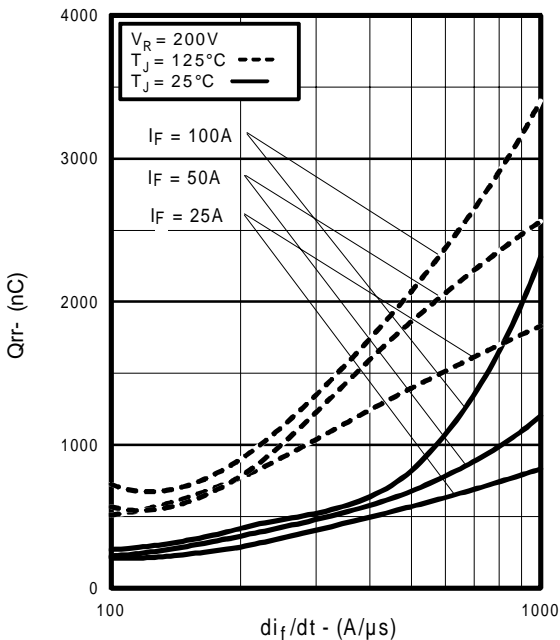

Fig. 16 - Typical Stored Charge vs.  $di/dt$

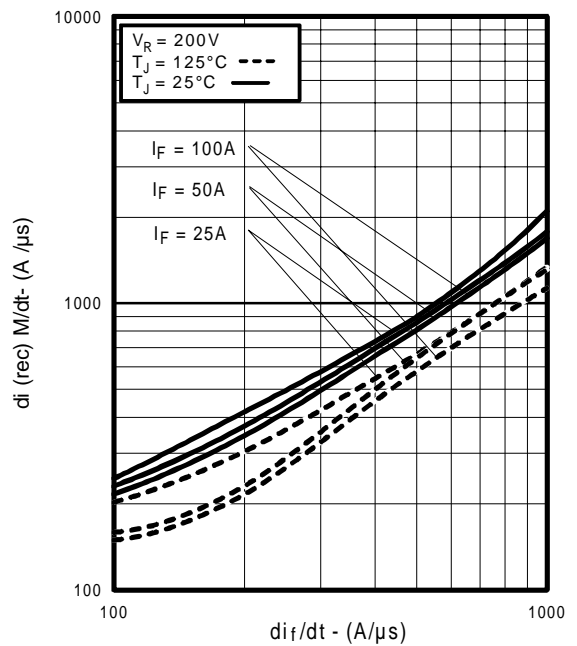
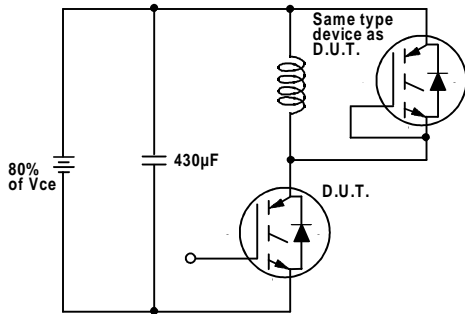
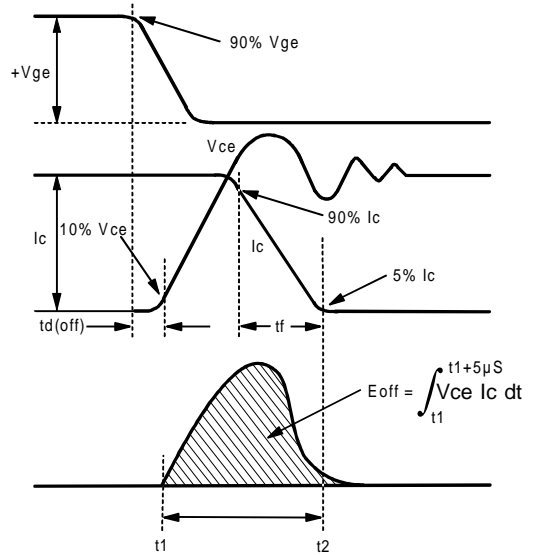

Fig. 17 - Typical  $di_{(rec)M}/dt$  vs.  $di/dt$



**Fig. 18a** - Test Circuit for Measurement of  $I_{LM}$ ,  $E_{on}$ ,  $E_{off(diode)}$ ,  $t_{rr}$ ,  $Q_{rr}$ ,  $I_{rr}$ ,  $t_{d(on)}$ ,  $t_r$ ,  $t_{d(off)}$ ,  $t_f$



**Fig. 18b** - Test Waveforms for Circuit of Fig. 18a, Defining  $E_{off}$ ,  $t_{d(off)}$ ,  $t_f$

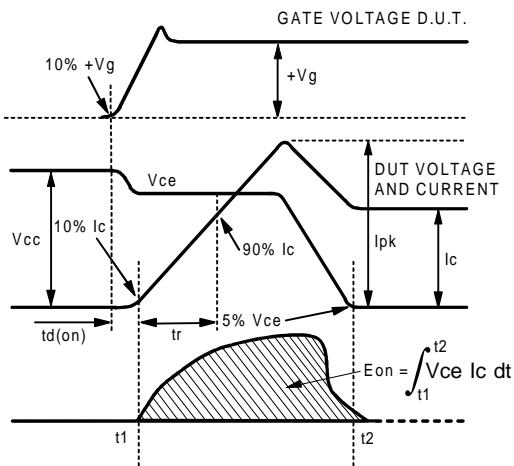

**Fig. 18c** - Test Waveforms for Circuit of Fig. 18a, Defining  $E_{on}$ ,  $t_{d(on)}$ ,  $t_r$

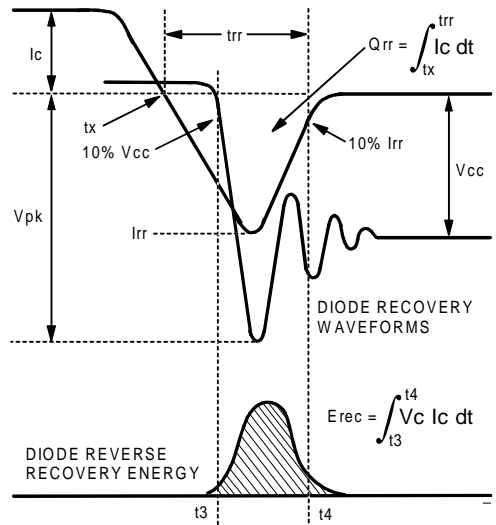

**Fig. 18d** - Test Waveforms for Circuit of Fig. 18a, Defining  $E_{rec}$ ,  $t_{rr}$ ,  $Q_{rr}$ ,  $I_{rr}$



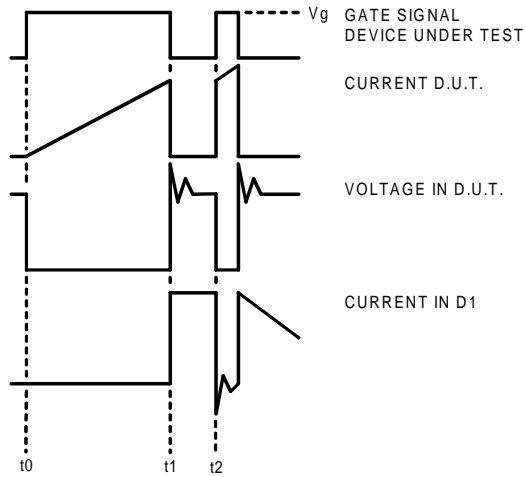

Figure 18e. Macro Waveforms for Figure 18a's Test Circuit

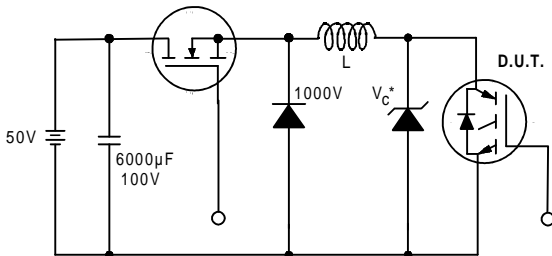

Figure 19. Clamped Inductive Load Test Circuit

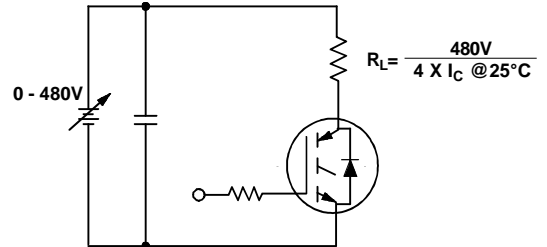
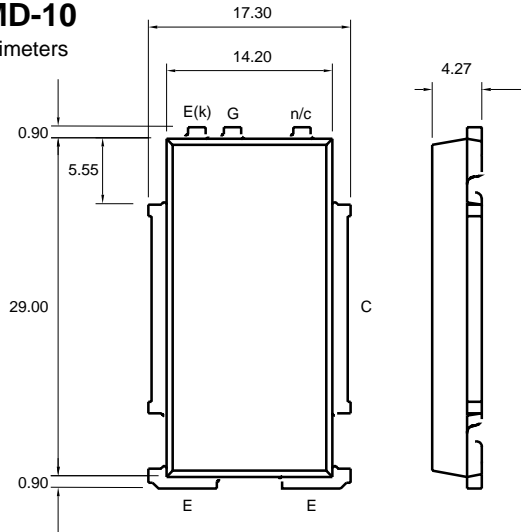

Figure 20. Pulsed Collector Current Test Circuit

## Case Outline — SMD-10

Dimensions are shown in millimeters



## Recommended footprint

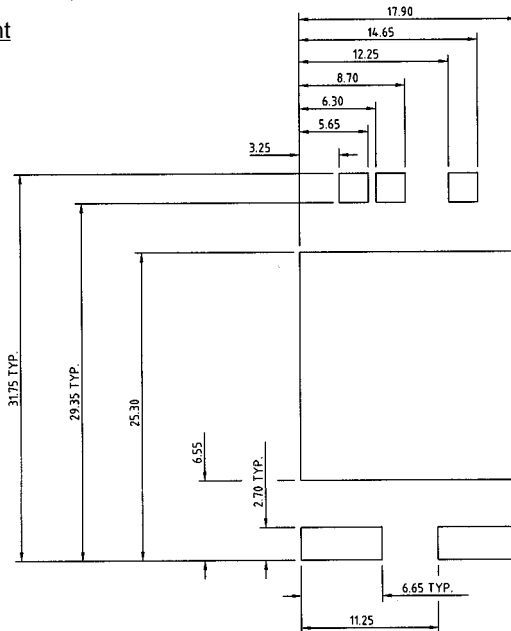

**WORLD HEADQUARTERS:** 233 Kansas St., El Segundo, California 90245, Tel: (310) 322 3331

**EUROPEAN HEADQUARTERS:** Hurst Green, Oxted, Surrey RH8 9BB, UK Tel: ++ 44 1883 732020

**IR CANADA:** 7321 Victoria Park Ave., Suite 201, Markham, Ontario L3R 2Z8, Tel: (905) 475 1897

**IR GERMANY:** Saalburgstrasse 157, 61350 Bad Homburg Tel: ++ 49 6172 96590

**IR ITALY:** Via Liguria 49, 10071 Borgaro, Torino Tel: ++ 39 11 451 0111

**IR FAR EAST:** K&H Bldg., 2F, 30-4 Nishi-Ikebukuro 3-Chome, Toshima-Ku, Tokyo Japan 171 Tel: 81 3 3983 0086

**IR SOUTHEAST ASIA:** 315 Outram Road, #10-02 Tan Boon Liat Building, Singapore 0316 Tel: 65 221 8371

<http://www.irf.com/> Data and specifications subject to change without notice. 3/98