



9-Mb Pipelined SRAM with QDR™ Architecture

Features

- Separate Independent Read and Write Data Ports
 - Supports concurrent transactions
- 167-MHz Clock for High Bandwidth
 - 2.5 ns Clock-to-Valid access time
- 2-Word Burst on all accesses
- Double Data Rate (DDR) interfaces on both Read & Write Ports (data transferred at 333 MHz) @ 167 MHz
- Two input clocks (K and \bar{K}) for precise DDR timing
 - SRAM uses rising edges only
- Two output clocks (C and \bar{C}) accounts for clock skew and flight time mis-matches
- Single multiplexed address input bus latches address inputs for both READ and WRITE ports
- Separate Port Selects for depth expansion
- Synchronous internally self-timed writes
- 2.5V core power supply with HSTL Inputs and Outputs
- 13x15 mm - 1.0 mm pitch FBGA package, 165 ball (11x15 matrix)
- Variable drive HSTL output buffers
- Expanded HSTL output voltage (1.4V-1.9V)
- JTAG Interface
- Variable Impedance HSTL

Functional Description

The CY7C1302V25 is a 2.5V Synchronous-Pipelined SRAM equipped with QDR™ architecture. QDR architecture consists of two separate ports to access the memory array. The Read port has dedicated Data Outputs to support Read operations and the Write Port has dedicated Data inputs to support Write operations. Access to each port is accomplished through a common address bus. The Read address is latched on the rising edge of the \bar{K} clock and the Write address is latched on the rising edge of \bar{K} clock. QDR has separate data inputs and data outputs to completely eliminate the need to “turn-around” the data bus required with common I/O devices. Accesses to the CY7C1302V25 Read and Write ports are completely independent of one another. All accesses are initiated synchronously on the rising edge of the positive input clock (K). In order to maximize data throughput, both Read and Write ports are equipped with Double Data Rate (DDR) interfaces. Therefore, data can be transferred into the device on every rising edge of both input clocks (K and \bar{K}) and out of the device on every rising edge of the output clock (C and \bar{C}) thereby maximizing performance while simplifying system design.

Depth expansion is accomplished with a Port Select input for each port. Each Port Selects allow each port to operate independently.

All synchronous inputs pass through input registers controlled by the K or \bar{K} input clocks. All data outputs pass through output registers controlled by the C or \bar{C} input clocks. Writes are conducted with on-chip synchronous self-timed write circuitry.

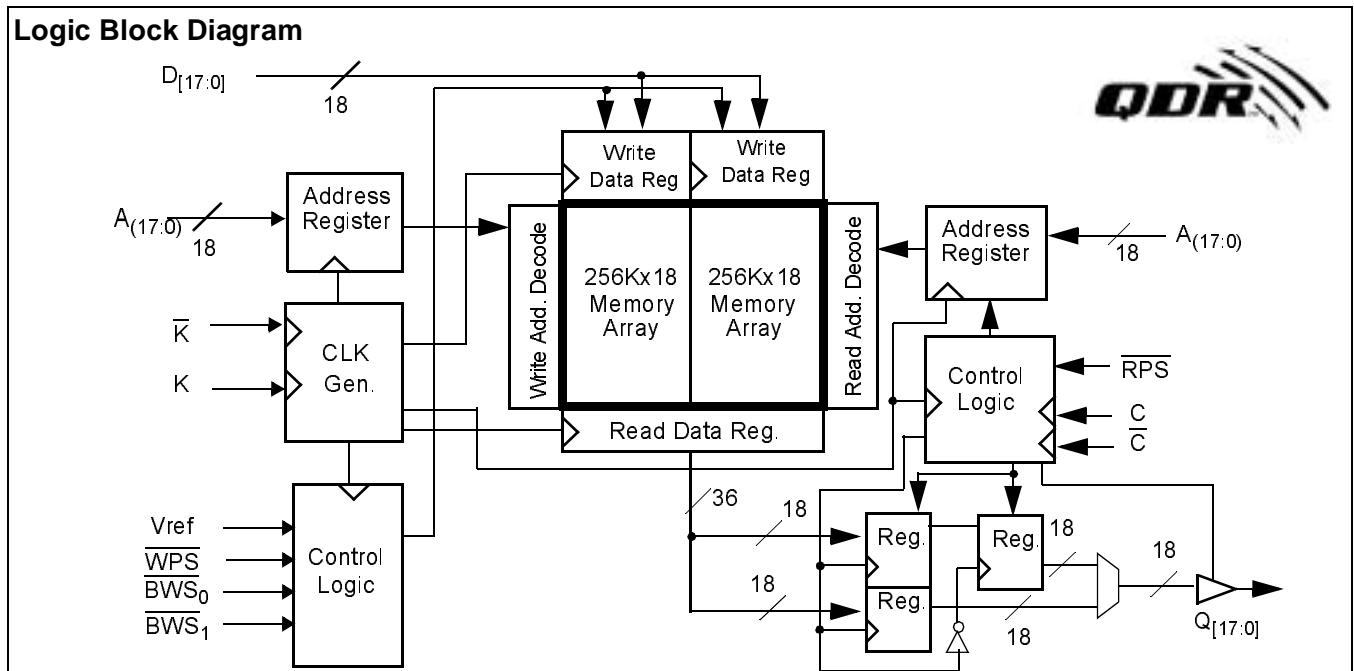

Selection Guide

	7C1302V25-167	7C1302V25-133	7C1302V25-100
Maximum Operating Frequency (MHz)	167	133	100
Maximum Operating Current (mA)	550	450	330

Pin Configuration
**CY7C1302V25
(Top View)**

	1	2	3	4	5	6	7	8	9	10	11
A	NC	Gnd/ 144M	NC/ 36M	\overline{WPS}	\overline{BWS}_1	\overline{K}	NC	RPS	NC/ 18M	Gnd/ 72M	NC
B	NC	Q9	D9	A	NC	K	\overline{BWS}_0	A	NC	NC	Q8
C	NC	NC	D10	VSS	A	A	A	VSS	NC	Q7	D8
D	NC	D11	Q10	VSS	VSS	VSS	VSS	VSS	NC	NC	D7
E	NC	NC	Q11	VDDQ	VSS	VSS	VSS	VDDQ	NC	D6	Q6
F	NC	Q12	D12	VDDQ	VDD	VSS	VDD	VDDQ	NC	NC	Q5
G	NC	D13	Q13	VDDQ	VDD	VSS	VDD	VDDQ	NC	NC	D5
H	NC	VREF	VDDQ	VDDQ	VDD	VSS	VDD	VDDQ	VDDQ	VREF	ZQ
J	NC	NC	D14	VDDQ	VDD	VSS	VDD	VDDQ	NC	Q4	D4
K	NC	NC	Q14	VDDQ	VSS	VSS	VDD	VDDQ	NC	D3	Q3
L	NC	Q15	D15	VDDQ	VSS	VSS	VSS	VDDQ	NC	NC	Q2
M	NC	NC	D16	VSS	VSS	VSS	VSS	VSS	NC	Q1	D2
N	NC	D17	Q16	VSS	A	A	A	VSS	NC	NC	D1
P	NC	NC	Q17	A	A	C	A	A	NC	D0	Q0
R	TDO	TCK	A	A	A	\overline{C}	A	A	A	TMS	TDI

Pin Definitions

Name	I/O	Description
$D_{[17:0]}$	Input-Synchronous	Data input signals, sampled on the rising edge of K and \bar{K} clocks during valid write operations.
\overline{WPS}	Input-Synchronous	Write Port Select, active LOW. Sampled on the rising edge of the K clock. When asserted active, a write operation is initiated. Deasserting will deselect the Write port. Deselecting the Write port will cause $D_{[17:0]}$ to be ignored.
$\overline{BWS}_0, \overline{BWS}_1$	Input-Synchronous	Byte Write Select 0 and 1, active LOW. Sampled on the rising edge of the K and \bar{K} clocks during write operations. Used to select which byte is written into the device during the current portion of the write operations. Bytes not written remain unaltered. \overline{BWS}_0 controls $D_{[8:0]}$ while \overline{BWS}_1 controls $D_{[17:9]}$. \overline{BWS}_0 and \overline{BWS}_1 are sampled on the same edge as $D_{[17:0]}$. Deselecting a Byte Write Select will cause the corresponding byte of data to be ignored and not written into the device.
$A_{(17:0)}$	Input-Synchronous	Address Inputs. Sampled on the rising edge of both the K and \bar{K} clocks during active read and write operations. These address inputs are multiplexed for both Read and Write operations. The Read address is latched on the rising edge of the positive input clock (K) and the Write address is latched on the rising edge of the negative input clock (\bar{K}). Internally, the device is organized 256Kx36. Therefore, only 18 address inputs are needed to access the entire memory array. These inputs are ignored when the appropriate port is deselected. Therefore, on the rising edge of the positive input clock (K), these inputs are ignored if the Read port is deselected. These inputs are ignored on the rising edge of the negative input clock (\bar{K}) when the Write port is deselected.
$Q_{[17:0]}$	Outputs-Synchronous	Data Output Signals. These pins drive out the requested data during a Read operation. Valid data is driven out on the rising edge of both the C and \bar{C} clocks during Read operations. When the Read port is deselected, $Q_{[17:0]}$ are automatically three-stated.
\overline{RPS}	Input-Synchronous	Read Port Select, active LOW. Sampled on the rising edge of positive input clock (K). When active, a Read operation is initiated. Deasserting will cause the Read port to be deselected. When deselected, the pending access is allowed to complete and the output drivers are automatically three-stated following the next rising edge of the C clock. The CY7C1302V25 is organized internally as 256Kx36. Each read access consists of a burst of two sequential 18-bit transfers.
C	Input-Clock	Positive Output Clock Input. C is used in conjunction with \bar{C} to clock out the Read data from the device. C and \bar{C} can be used together to deskew the flight times of various devices on the board back to the controller. See application example for further details.
\bar{C}	Input-Clock	Negative Output Clock Input. \bar{C} is used in conjunction with C to clock out the Read data from the device. C and \bar{C} can be used together to deskew the flight times of various devices on the board back to the controller. See application example for further details.
K	Input-Clock	Positive Input Clock Input. The rising edge of K is used to capture synchronous inputs to the device and to drive out data through $Q_{[17:0]}$ when in single clock mode. All accesses are initiated on the rising edge of K.
\bar{K}	Input-Clock	Negative Input Clock Input. \bar{K} is used to capture synchronous inputs being presented to the device and to drive out data through $Q_{[17:0]}$ when in single clock mode.
ZQ	Input	Output Impedance Matching Input. This input is used to tune the device outputs to the system data bus impedance. $Q_{[17:0]}$ output impedance are set to $0.2 \times RQ$, where RQ is a resistor connected between ZQ and ground. Alternately, this pin can be connected directly to V_{DD} , which enables the minimum impedance mode. This pin cannot be connected directly to GND or left unconnected.

Pin Definitions (continued)

TDO	Output	TDO for JTAG.
TCK	Input	TCK pin for JTAG.
TDI	Input	TDI pin for JTAG.
TMS	Input	TMS pin for JTAG.
NC/18M	Input	Address expansion for 18M. This is not connected to the die.
NC/36M	Input	Address expansion for 36M. This is not connected to the die.
GND/72M	Input	Address expansion for 72M. This should be tied low on the CY7C1302V25
GND/144M	Input	Address expansion for 144M. This should be tied low on the CY7C1302V25
NC		Not Connect Pins. These are not connected to the die.
V _{REF}	Input-Reference	Reference Voltage Input. Static input used to set the reference level for HSTL inputs and Outputs as well as A/C measurement points.
V _{DD}	Power Supply	Power supply inputs to the core of the device. Should be connected to 2.5V power supply.
V _{SS}	Ground	Ground for the device. Should be connected to ground of the system.
V _{DDQ}	Power Supply	Power supply inputs for the outputs of the device. Should be connected to 1.5V power supply.

Introduction
Functional Overview

The CY7C1302V25 is a Synchronous Pipelined Burst SRAM equipped with both a Read Port and a Write Port. The Read port is dedicated to Read operations and the Write Port is dedicated to Write operations. Data flows into the SRAM through the Write port and out through the Read Port. The CY7C1302V25 multiplexes the address inputs in order to minimize the number of address pins required. The CY7C1302V25 latches the Read address on the rising edge of the positive input clock (K) and latches the Write address on the rising edge of the negative input clock (\overline{K}). By having separate Read and Write ports, the CY7C1302V25 completely eliminates the need to “turn-around” the data bus and avoids any possible data contention, thereby simplifying system design.

Accesses for both ports are initiated by the positive input clock (K). All synchronous input timing is referenced from the rising edge of the input clocks (K and \overline{K}) and all output timing is referenced to the output clocks (C and \overline{C}) or K and \overline{K} when in single clock mode.

All synchronous data inputs ($D_{[17:0]}$) inputs pass through input registers controlled by the input clocks (K and \overline{K}). All synchronous data outputs ($Q_{[17:0]}$) outputs pass through output registers controlled by the rising edge of the output clocks (C and \overline{C})

All synchronous control (\overline{RPS} , \overline{WPS} , \overline{BWS}_0 , \overline{BWS}_1) inputs pass through input registers controlled by the rising edge of the input clocks (K and \overline{K}).

Read Operations

Read operations are initiated by asserting \overline{RPS} active at the rising edge of the positive input clock (K). The address presented to $A_{[17:0]}$ is stored in the Read address register. Because the CY7C1302V25 is a 36-bit memory, it will access two 18-bit data words with each read operation. Following the next K clock rise the data is available to be latched out of the device, triggered by the C clock. On the following C clock rise the corresponding lower order word of data is driven onto the $Q_{[17:0]}$. On the subsequent rising edge of C the higher order data word

is driven onto the $Q_{[17:0]}$. The requested data will be valid 2.5ns from the rising edge of the output clock (C or \overline{C} , 167-MHz device). With the separate Input and Output ports and the internal logic determining when the device should drive the data bus, the QDR architecture has eliminated the need for an output enable input to control the state of the output drivers.

Read accesses can be initiated on every rising edge of the Positive Input Clock (K). Doing so will pipeline the data flow such that data is transferred out of the device on every rising edge of the output clocks (C and \overline{C}). The CY7C1302V25 will deliver the most recent data for the address location being accessed. This includes forwarding data when a Read and Write transactions to the same address location are initiated on the same clock rise.

When the read port is deselected, the CY7C1302V25 will first complete the pending read transactions. Synchronous internal circuitry will automatically three-state the outputs following the next rising edge of the Positive Output Clock (C). This will allow for a seamless transition between devices without the insertion of wait states.

The CY7C1302V25 is equipped with internal logic that synchronously controls the state of the output drivers. The logic inside the device determines when the output drivers need to be active or inactive. This advanced logic eliminates the need for an Asynchronous Output Enable (\overline{OE}) since the device will automatically enable/disable the output drivers during the proper cycles. The CY7C1302V25 will automatically power-up in a deselected state with the outputs in a three state condition.

Write Operations

Write operations are initiated by asserting \overline{WPS} active at the rising edge of the Positive Input Clock (K). On the same clock rise (K) the data presented to $D_{[17:0]}$ is stored into the lower 18-bit Write Data register provided $\overline{BWS}_{[1:0]}$ are both asserted active. On the subsequent rising edge of the Negative Input Clock (\overline{K}), the information presented to $A_{[17:0]}$ is latched and stored in the Write Address Register and the information presented to $D_{[17:0]}$ is also stored into the upper 18-bit Write Data Register provided $\overline{BWS}_{[1:0]}$ are both asserted active. The 36 bits of data are then written into the memory array at the specified location.

Write accesses can be initiated on every rising edge of the positive clock. Doing so will pipeline the data flow such that 18-bits of data can be transferred into the device on every rising edge of the input clocks (K and \bar{K}).

Byte Write operations are supported by the CY7C1302V25. A write operation is initiated by selecting the write port using \overline{WPS} . The bytes that are written are determined by \overline{BWS}_0 and \overline{BWS}_1 which are sampled with each set of 18-bit data word. Asserting the appropriate Byte Write Select input during the data portion of a write will allow the data being presented to be latched and written into the device. De-asserting the Byte Write Select input during the data portion of a write will allow the data stored in the device for that byte to remain unaltered. This feature can be used to simplify READ/MODIFY/WRITE operations to a Byte Write operation.

When deselected, the write port will ignore all inputs.

Single Clock Mode

The CY7C1302V25 can be used with a single clock mode. In this mode the device will recognize only the pair of input clocks (K and \bar{K}) that control both the input and output registers. This operation is identical to the operation if the device had zero skew between the \overline{K}/\bar{K} and \overline{C}/\bar{C} clocks. All timing parameters remain the same in this mode. To use this mode of operation, the user must tie C and \bar{C} to V_{DD} . During power-up, the device will sense the single clock input and operating in either single clock or double clock mode. The clock mode should not be changed during device operation.

Concurrent Transactions

The Read and Write ports on the CY7C1302V25 operate completely independently of one another. Since each port latches

the address inputs on different clock edges, the user can Read or Write to any location, regardless of the transaction on the other port. Should the Read and Write ports access the same location on the rising edge of the positive input clock, the information presented to the $D_{[17:0]}$ will be forwarded to the $Q_{[17:0]}$ such that no latency is required to access valid data. Coherency is conducted on cycle boundaries. Once the second word of data is latched into the device, the write operation is considered completed. At this point, any access to that address location will receive that data until altered by a subsequent Write operation. Coherency is not maintained for Write operations initiated in the cycle after a Read.

Depth Expansion

The CY7C1302V25 has a Port Select input for each port. This allows for easy depth expansion. Both Port Selects are sampled on the rising edge of the Positive Input Clock only (K). Each port select input can deselect the specified port. Deselecting a port will not affect the other port. All pending transactions (Read and Write) will be completed prior to the device being deselected.

Programmable Impedance

An external resistor, RQ, must be connected between the ZQ pin on the SRAM and V_{SS} to allow the SRAM to adjust its output driver impedance. The value of RQ must be 5X the value of the intended line impedance driven by the SRAM. The allowable range of RQ to guarantee impedance matching with a tolerance of +/-10% is between 175 Ω and 350 Ω , with $V_{DDQ}=1.5V$. The output impedance is adjusted every 1024 cycles to adjust for drifts in supply voltage and temperature.

Application Example

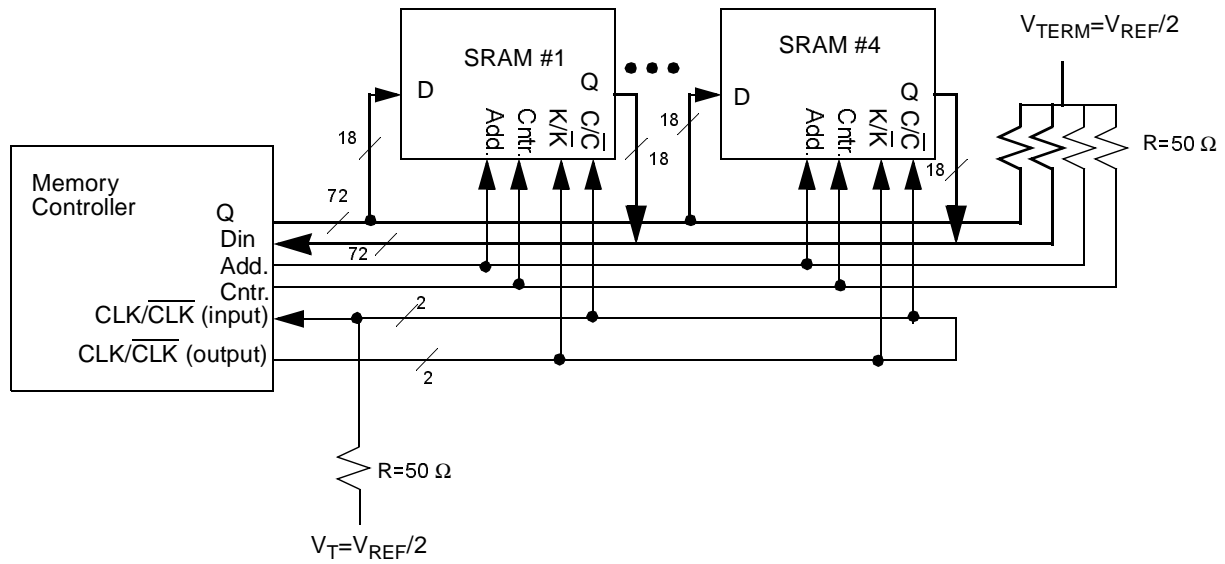

CY7C1302V25

Truth Table^[1, 2, 3, 4, 5]

Operation	Address Used	$\overline{\text{RPS}}$	K	Comments
Deselected	-	H	L-H	Read Port is deselected. Outputs three-state following next rising edge of negative input clock ($\overline{\text{K}}$) if in single clock mode, or $\overline{\text{C}}$ if using C and $\overline{\text{C}}$ as the output clocks.
Begin Read	External	L	L-H	Read operation initiated. Addresses are stored in the Read Address Register. Following the next K clock rise the first (lower order) 18-bit word will be available to be driven out onto $\text{Q}_{[17:0]}$ gated by the rising edge of the output clock C. On the subsequent rising edge of the negative output clock ($\overline{\text{C}}$) the second (higher order) 18-bit word is driven out onto $\text{Q}_{[17:0]}$.
Deselected	-	H	L-H	$\overline{\text{WPS}}$ deselected Write Port. All Write Port inputs are ignored during this clock rise and the subsequent rising edge of the negative input clock ($\overline{\text{K}}$).
Begin Write	External on next rising edge of K	L	L-H	Write operation initiated. The information presented to $\text{D}_{[17:0]}$ is stored in the Write Data Register. On the subsequent rising edge of the negative input clock ($\overline{\text{K}}$) the device will latch the addresses presented to $\text{A}_{[17:0]}$ and the data presented to $\text{D}_{[17:0]}$. The entire 36 bits of information will then be written into the memory array. See Write Description table for byte write information,

Note:

1. X="Don't Care", H=Logic HIGH, L=Logic LOW.
2. Device will power-up deselected and the outputs in a three-state condition.
3. BWS_0 and BWS_1 asserted active LOW during all cycles. For byte write operations, see Write Description Table.
4. Data inputs are registered at $\overline{\text{K}}$ and $\overline{\text{K}}$ rising edges. Data outputs are delivered on C and $\overline{\text{C}}$ rising edges, except when in single clock mode.
5. It is recommended that $\text{K} = \text{K}\#$ and $\text{C} = \text{C}\#$ when clock is stopped. This is not essential, but permits most rapid restart by overcoming transmission line charging symmetrically.

Write Descriptions^[6]

Operation	\overline{BWS}_0	\overline{BWS}_1	K	\overline{K}	Comments
Write Initiated	L	L	L-H	-	Both bytes (D _[17:0]) are written into the lower order 18-bit write buffer device during this portion of a write operation.
Write Completed - Write initiated on previous K clock rise	L	L	-	L-H	Both bytes (D _[17:0]) are written into the higher order 18-bit write buffer device during this portion of a write operation. The contents of the entire 36-bits write buffer are written into the memory array.
Write Initiated	L	H	L-H	-	Only Byte 0 (D _[8:0]) is written into the lower order 18-bit write buffer of the device during this portion of a write operation. Byte 1 (D _[17:9]) remains unaltered.
Write Completed - Write initiated on previous K clock rise	L	H	-	L-H	Only Byte 0 (D _[8:0]) is written into the higher order 18-bit write buffer of the device during this portion of a write operation. Byte 1 (D _[17:9]) remains unaltered. Byte 0 is then written into the memory array.
Write Initiated	H	L	L-H	-	Only Byte 1 (D _[17:9]) is written into the lower order 18-bit write buffer of the device during this portion of a write operation. Byte 0 (D _[8:0]) remains unaltered
Write Completed - Write initiated on previous K clock rise	H	L	-	L-H	Only Byte 1 (D _[17:9]) is written into the higher order 18-bit write buffer of the device during this portion of a write operation. Byte 0 (D _[8:0]) remains unaltered. Byte 0 is then written into the memory array.
Write - NO-OP	H	H	L-H	-	No data is written into the device during this portion of a write operation.
Write - NO-OP	H	H	-	L-H	No data is written into the device during this portion of a write operation.

Note:

6. Assumes a Write cycle was initiated per the Write Port Cycle Description Truth Table. \overline{BWS}_0 and \overline{BWS}_1 can be altered on different portions of a write cycle, as long as the set-up and hold requirements are achieved.

IEEE 1149.1 Serial Boundary Scan (JTAG - FBGA Only)

The CY7C1302V25 incorporates a serial boundary scan test access port (TAP) in the FBGA package only. The TQFP package does not offer this functionality. This port operates in accordance with IEEE Standard 1149.1-1900, but does not have the set of functions required for full 1149.1 compliance. These functions from the IEEE specification are excluded because their inclusion places an added delay in the critical speed path of the SRAM. Note that the TAP controller functions in a manner that does not conflict with the operation of other devices using 1149.1 fully compliant TAPs. The TAP operates using JEDEC standard 2.5V I/O logic levels.

Disabling the JTAP Feature

It is possible to operate the SRAM without using the JTAG feature. To disable the TAP controller, TCK must be tied LOW (V_{SS}) to prevent clocking of the device. TDI and TMS are internally pulled up and may be unconnected. They may alternately be connected to VDD through a pull-up resistor. TDO should be left unconnected. Upon power-up, the device will come up in a reset state which will not interfere with the operation of the device.

Test Access Port (TAP) - Test Clock

The test clock is used only with the TAP controller. All inputs are captured on the rising edge of TCK. All outputs are driven from the falling edge of TCK.

Test Mode Select

The TMS input is used to give commands to the TAP controller and is sampled on the rising edge of TCK. It is allowable to leave this pin unconnected if the TAP is not used. The pin is pulled up internally, resulting in a logic HIGH level.

Test Data-In (TDI)

The TDI pin is used to serially input information into the registers and can be connected to the input of any of the registers. The register between TDI and TDO is chosen by the instruction that is loaded into the TAP instruction register. For information on loading the instruction register, see the TAP Controller State Diagram. TDI is internally pulled up and can be unconnected if the TAP is unused in an application. TDI is connected to the Most Significant Bit (MSB) on any register.

Test Data Out (TDO)

The TDO output pin is used to serially clock data-out from the registers. The output is active depending upon the current state of the TAP state machine (See TAP Controller State Diagram). The output changes on the falling edge of TCK. TDO is connected to the Least Significant Bit (LSB) of any register.

Performing a TAP Reset

A RESET is performed by forcing TMS HIGH (VDD) for five rising edges of TCK. This RESET does not affect the operation of the SRAM and may be performed while the SRAM is operating. At power-up, the TAP is reset internally to ensure that TDO comes up in a high-Z state.

TAP Registers

Registers are connected between the TDI and TDO pins and allow data to be scanned into and out of the SRAM test circuitry. Only one register can be selected at a time through the instruction register. Data is serially loaded into the TDI pin on the rising edge of TCK. Data is output on the TDO pin on the falling edge of TCK.

Instruction Register

Three-bit instructions can be serially loaded into the instruction register. This register is loaded when it is placed between the TDI and TDO pins as shown in the TAP Controller Block Diagram. Upon power-up, the instruction register is loaded with the IDCODE instruction. It is also loaded with the IDCODE instruction if the controller is placed in a reset state as described in the previous section.

When the TAP controller is in the Capture-IR state, the two least significant bits are loaded with a binary "01" pattern to allow for fault isolation of the board level serial test data path.

Bypass Register

To save time when serially shifting data through registers, it is sometimes advantageous to skip certain chips. The bypass register is a single-bit register that can be placed between TDI and TDO pins. This allows data to be shifted through the SRAM with minimal delay. The bypass register is set LOW (VSS) when the BYPASS instruction is executed.

Boundary Scan Register

The boundary scan register is connected to all the input and output pins on the SRAM. Several no connect (NC) pins are also included in the scan register to reserve pins for higher density devices.

The boundary scan register is loaded with the contents of the RAM Input and Output ring when the TAP controller is in the Capture-DR state and is then placed between the TDI and TDO pins when the controller is moved to the Shift-DR state. The EXTEST, SAMPLE/PRELOAD and SAMPLE Z instructions can be used to capture the contents of the Input and Output ring.

The Boundary Scan Order tables show the order in which the bits are connected. Each bit corresponds to one of the bumps on the SRAM package. The MSB of the register is connected to TDI, and the LSB is connected to TDO.

Identification (ID) Register

The ID register is loaded with a vendor-specific, 32-bit code during the Capture-DR state when the IDCODE command is loaded in the instruction register. The IDCODE is hardwired into the SRAM and can be shifted out when the TAP controller is in the Shift-DR state. The ID register has a vendor code and other information described in the Identification Register Definitions table.

TAP Instruction Set

Eight different instructions are possible with the three-bit instruction register. All combinations are listed in the Instruction Codes table. Three of these instructions are listed as RESERVED and should not be used. The other five instructions are described in detail below.

The TAP controller used in this SRAM is not fully compliant to the 1149.1 convention because some of the mandatory 1149.1 instructions are not fully implemented. The TAP controller cannot be used to load address, data or control signals into the SRAM and cannot preload the Input or output buffers. The SRAM does not implement the 1149.1 commands EXTEST or INTEST or the PRELOAD portion of SAMPLE / PRELOAD; rather it performs a capture of the Inputs and Output ring when these instructions are executed.

Instructions are loaded into the TAP controller during the Shift-IR state when the instruction register is placed between TDI and TDO. During this state, instructions are shifted through the instruction register through the TDI and TDO pins. To execute the instruction once it is shifted in, the TAP controller needs to be moved into the Update-IR state.

EXTEST

EXTEST is a mandatory 1149.1 instruction which is to be executed whenever the instruction register is loaded with all 0s. EXTEST is not implemented in the CY7C1304 TAP controller, and therefore this device is not compliant to the 1149.1 standard.

The TAP controller does recognize an all-0 instruction. When an EXTEST instruction is loaded into the instruction register, the SRAM responds as if a SAMPLE / PRELOAD instruction has been loaded.

IDCODE

The IDCODE instruction causes a vendor-specific, 32-bit code to be loaded into the instruction register. It also places the instruction register between the TDI and TDO pins and allows the IDCODE to be shifted out of the device when the TAP controller enters the Shift-DR state. The IDCODE instruction is loaded into the instruction register upon power-up or whenever the TAP controller is given a test logic reset state.

SAMPLE Z

The SAMPLE Z instruction causes the boundary scan register to be connected between the TDI and TDO pins when the TAP controller is in a Shift-DR state.

SAMPLE / PRELOAD

SAMPLE / PRELOAD is a 1149.1 mandatory instruction. The PRELOAD portion of this instruction is not implemented, so the CY7C1302V25 TAP controller is not fully 1149.1 compliant.

When the SAMPLE / PRELOAD instructions is loaded into the instruction register and the TAP controller is in the Capture-DR state, a snapshot of data on the inputs and output pins is captured in the boundary scan register.

The user must be aware that the TAP controller clock can only operate at a frequency up to 10 MHz, while the SRAM clock operates more than an order of magnitude faster. Because there is a large difference in the clock frequencies, it is possible that during the Capture-DR state, an input or output will undergo a transition. The TAP may then try to capture a signal while

in transition (metastable state). This will not harm the device, but there is no guarantee as to the value that will be captured. Repeatable results may not be possible.

To guarantee that the boundary scan register will capture the correct value of a signal, the SRAM signal must be stabilized long enough to meet the TAP controller's capture setup plus hold times (TCS and TCH). The SRAM clock input might not be captured correctly if there is no way in a design to stop (or slow) the clock during a SAMPLE / PRELOAD instruction. If this is an issue, it is still possible to capture all other signals and simply ignore the value of the K, K, C and \bar{C} captured in the boundary scan register.

Once the data is captured, it is possible to shift out the data by putting the TAP into the Shift-DR state. This places the boundary scan register between the TDI and TDO pins.

Note that since the PRELOAD part of the command is not implemented, putting the TAP into the Update-DR state while performing a SAMPLE / PRELOAD instruction will have the same effect as the Pause-DR command.

Bypass

When the BYPASS instruction is loaded in the instruction register and the TAP is placed in a Shift-DR state, the bypass register is placed between the TDI and TDO pins. The advantage of the BYPASS instruction is that it shortens the boundary scan path when multiple devices are connected together on a board.

Reserved

These instructions are not implemented but are reserved for future use. Do not use these instructions.

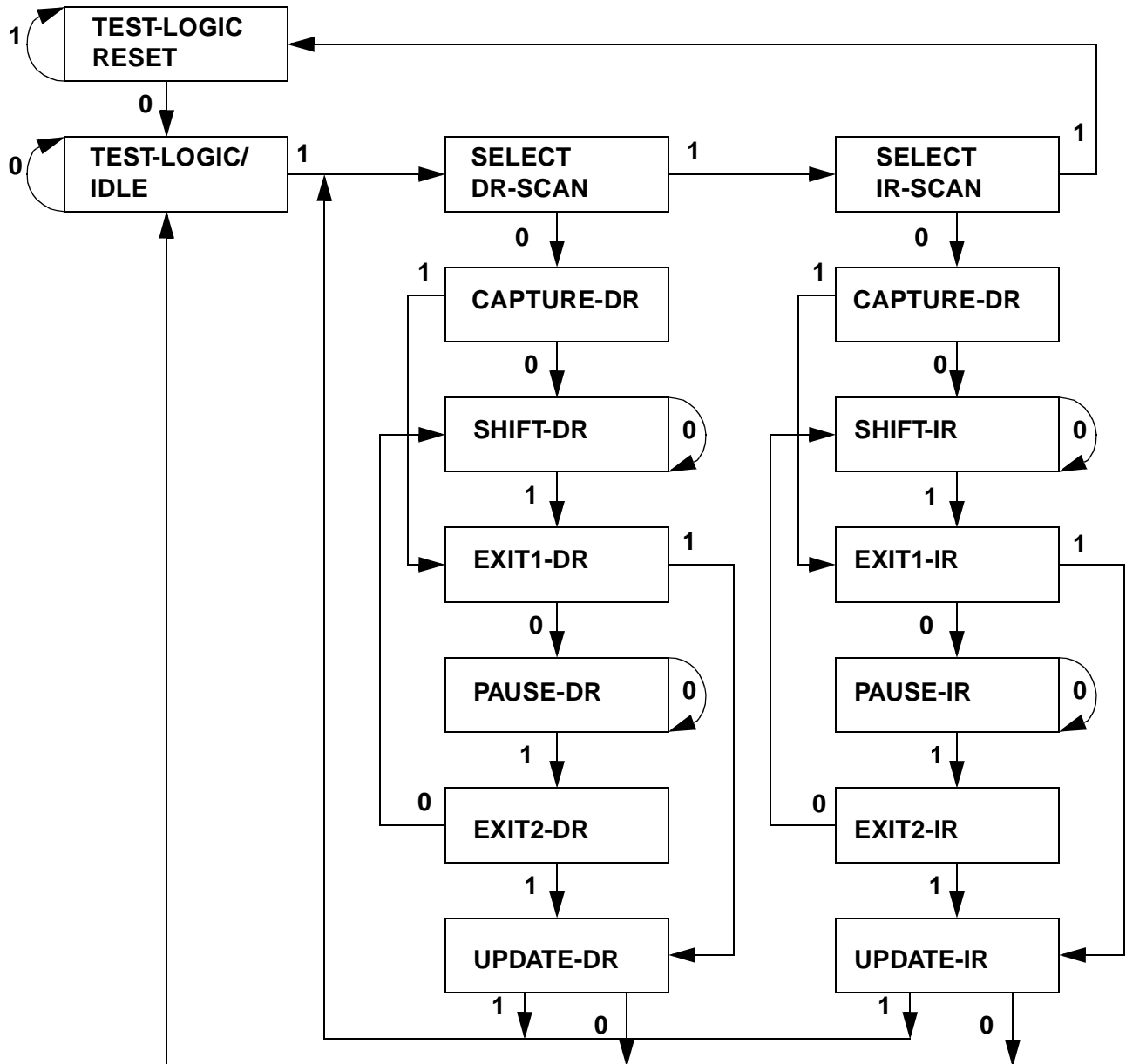
TAP Controller State Diagram

Note: The 0/1 next to each state represents the value at TMS at the rising edge of TCK.

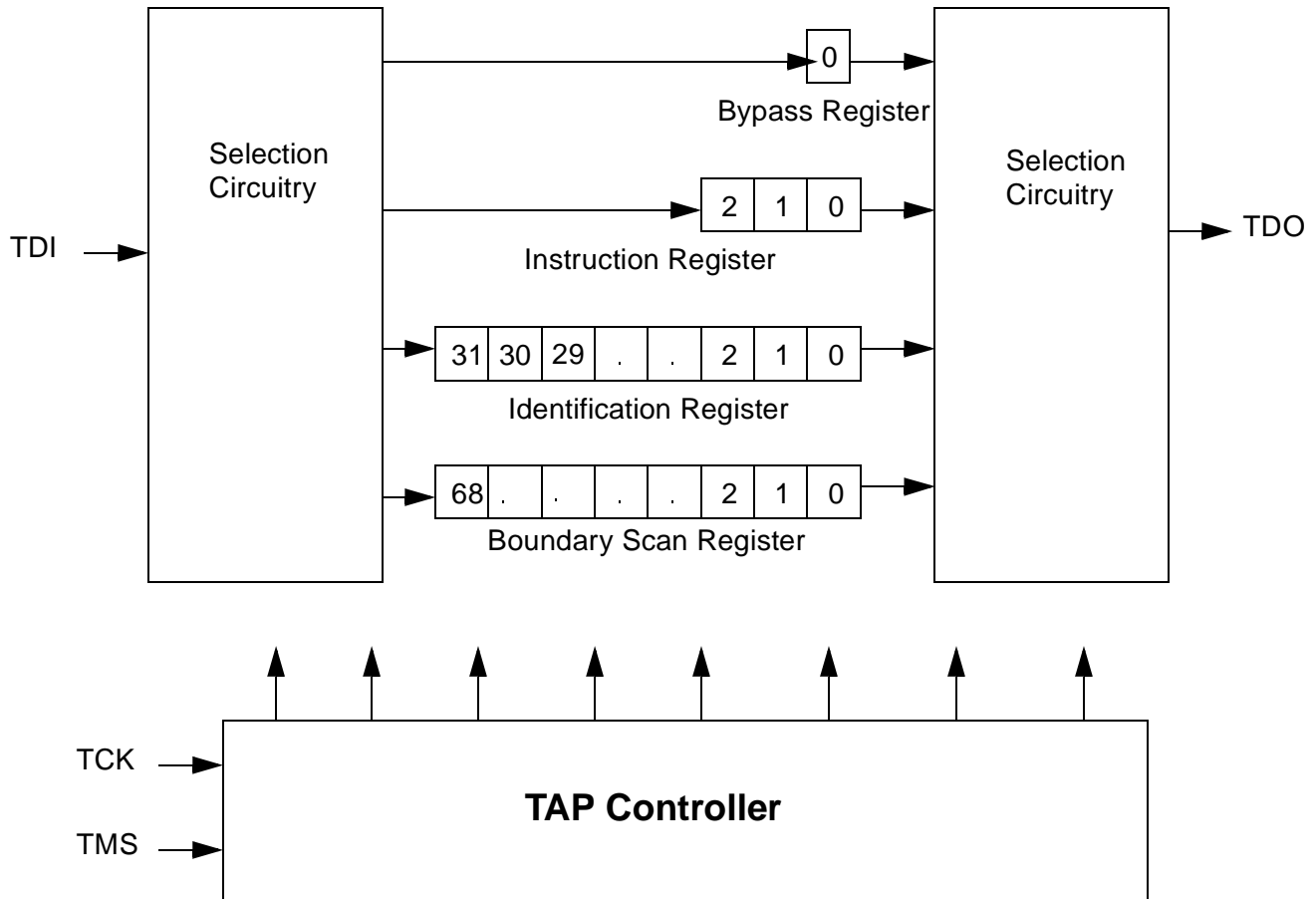
TAP Controller Block Diagram

TAP Electrical Characteristics Over the Operating Range^[7, 8, 9]

Parameter	Description	Test Conditions	Min.	Max.	Unit
V _{OH1}	Output HIGH Voltage	I _{OH} = -2.0mA	1.7		V
V _{OH2}	Output HIGH Voltage	I _{OH} = -100μA	2.1		V
V _{OL1}	Output LOW Voltage	I _{OL} = 2.0mA		0.7	V
V _{OL2}	Output LOW Voltage	I _{OL} = 100μA		0.2	V
V _{IH}	Input HIGH Voltage		1.7	V _{DD} +0.3	V
V _{IL}	Input LOW Voltage		-0.3	0.7	V
I _X	Input and Output Load Current	GND ≤ V _I ≤ V _{DDQ}	-5	5	μA

7. All Voltage referenced to Ground.

8. Overshoot: V_{IH(AC)} ≤ V_{DD}+1.5V for t_{≤t_{TCYC}/2}, Undershoot: V_{IL(AC)} ≤ 0.5V for t_{≤t_{TCYC}/2}. Power-up: V_{IH} < 2.6V and V_{DD} < 2.4V and V_{DDQ} < 1.4V for t < 200 ms.

9. These characteristic pertain to the TAP inputs (TMS, TCK, TDI and TDO). Parallel load levels are specified in the Electrical Characteristics Table

TAP AC Switching Characteristics Over the Operating Range^[10, 11]

Param	Description	Min.	Max	Unit
t _{TCYC}	TCK Clock Cycle Time	100		ns
t _{TF}	TCK Clock Frequency		10	MHz
t _{TH}	TCK Clock HIGH	40		ns
t _{TL}	TCK Clock LOW	40		ns
Set-up Times				
t _{TMSS}	TMS set-up to TCK clock rise	10		ns
t _{TDIS}	TDI set-up to TCK clock rise	10		ns
t _{CS}	Capture set-up to TCK rise	10		ns
Hold Times				
t _{TMSH}	TMS Hold after TCK clock rise	10		ns
t _{TDIH}	TDI Hold after clock rise	10		ns
t _{CH}	Capture Hold after clock rise	10		ns
Output Times				
t _{TDOV}	TCK Clock LOW to TDO valid		20	ns
t _{TDOX}	TCK Clock LOW to TDO invalid	0		ns

Notes:

10. t_{CS} and t_{CH} refer to the set-up and hold time requirements of latching data from the boundary scan register.

11. Test conditions are specified using the load in TAP AC test conditions. t_r/t_f= 1ns.

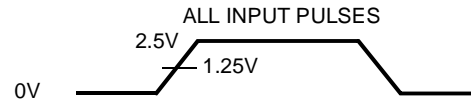
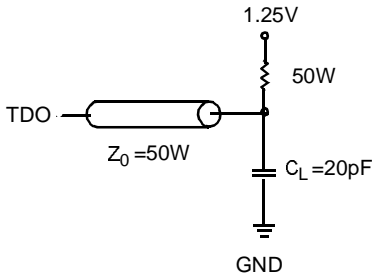
TAP Timing and Test Conditions^[11]

(a)

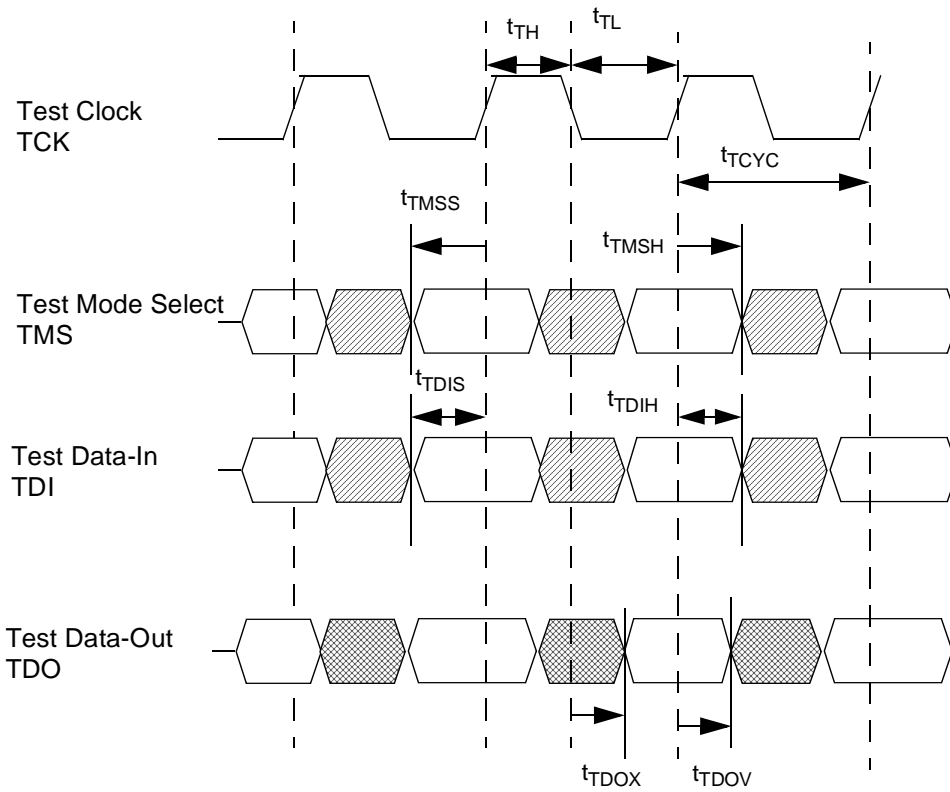

Identification Register Definitions

Instruction Field	Value (CY7C1302V25)	Description
Revision Number (31:29)	000	Version number.
Cypress Device ID (28:12)	01011010010010110	Defines the type of SRAM.
Cypress JEDEC ID (11:1)	00000110100	Allows unique identification of SRAM vendor.
ID Register Presence (0)	1	Indicate the presence of an ID register.

Scan Register sizes

Register Name	Bit Size
Instruction	3
Bypass	1
ID	32
Boundary Scan	69

Instruction Codes

Instruction	Code	Description
EXTEST	000	Captures the Input/Output ring contents. Places the boundary scan register between the TDI and TDO. This instruction is not 1149.1 compliant. <i>The EXTEST command implemented by the CY7C1302V25 device will NOT place the output buffers into a HIGH-Z condition. If the output buffers need to be HIGH-Z condition, this can be accomplished by deselecting the Read port.</i>
IDCODE	001	Loads the ID register with the vendor ID code and places the register between TDI and TDO. This operation does not affect SRAM operation.
SAMPLE Z	010	Captures the Input/Output contents. Places the boundary scan register between TDI and TDO. <i>The SAMPLEZ command implemented by the CY7C1302V25 device will place the output buffers into a HIGH-Z condition.</i>
RESERVED	011	Do Not Use: This instruction is reserved for future use.
SAMPLE/PRELOAD	100	Captures the Input/Output ring contents. Places the boundary scan register between TDI and TDO. Does not affect the SRAM operation. This instruction does not implement 1149.1 preload function and is therefore not 1149.1 compliant.
RESERVED	101	Do Not Use: This instruction is reserved for future use.
RESERVED	110	Do Not Use: This instruction is reserved for future use.
BYPASS	111	Places the bypass register between TDI and TDO. This operation does not affect SRAM operation.

Boundary Scan Order (#1 Exits Device First)

Bit #	Signal Name	Bump ID
1	\overline{C}	6R
2	C	6P
3	A	6N
4	A	7P
5	A	7N
6	A	7R
7	A	8R
8	A	8P
9	A	9R
10	D0	10P
11	Q0	11P
12	D1	11N
13	Q1	10M
14	D2	11M
15	Q2	11L
16	D3	10K
17	Q3	11K
18	D4	11J
19	ZQ	11H
20	Q4	10J
21	D5	11G
22	Q5	11F
23	D6	10E
24	Q6	11E
25	D7	11D
26	Q7	10C
27	D8	11C
28	Q8	11B
29	Reserved	12A (Don't Care)
30	GND/72M	10A
31	NC/18M(1)	9A (Read as 1, 18 Mb)
32	A	8B
33	A	7C
34	A	6C
35	\overline{RPS}	8A
36	$\overline{BWS0}$	7B

Boundary Scan Order (#1 Exits Device First)

Bit #	Signal Name	Bump ID
37	K	6B
38	\overline{K}	6A
39	$\overline{BWS1}$	5A
40	\overline{WPS}	4A
41	A	5C
42	A	4B
43	NC/36M(1)	3A
44	GND/144M	2A
45	Reserved	1A (Don't Care)
46	D9	3B
47	Q9	2B
48	D10	3C
49	Q10	3D
50	D11	2D
51	Q11	3E
52	D12	3F
53	Q12	2F
54	D13	2G
55	Q13	3G
56	D14	3J
57	Q14	3K
58	D15	3L
59	Q15	2L
60	D16	3M
61	Q16	3N
62	D17	2N
63	Q17	3P
64	A	3R
65	A	4R
66	A	4P
67	A	5P
68	A	5N
69	A	5R

Maximum Ratings

(Above which the useful life may be impaired. For user guidelines, not tested.)

Storage Temperature -65C to +150C
 Ambient Temperature with
 Power Applied -55C to +125C
 Supply Voltage on V_{DD} Relative to GND -0.5V to +3.6V
 DC Voltage Applied to Outputs
 in High Z State^[12] -0.5V to $V_{DDQ} + 0.5V$
 DC Input Voltage^[12] -0.5V to $V_{DDQ} + 0.5V$

Current into Outputs (LOW) 20 mA
 Static Discharge Voltage >2001V
 (per MIL-STD-883, Method 3015)
 Latch-Up Current >200 mA

Operating Range

Range	Ambient Temperature ^[13]	V_{DD}	V_{DDQ}
Com'l	0°C to +70°C	2.5+/-100mV	1.4V to 1.9V

Electrical Characteristics Over the Operating Range

Parameter	Description	Test Conditions	Min.	Max.	Unit
V_{DD}	Power Supply Voltage		2.4	2.6	V
V_{DDQ}	I/O Supply Voltage		1.4	1.9	V
V_{OH}	Output HIGH Voltage	$I_{OH} = -2.0mA$, nominal impedance	$V_{DDQ}/2+0.3$	V_{DDQ}	V
V_{OL}	Output LOW Voltage	$I_{OL} = 2.0mA$, nominal impedance	V_{SS}	$V_{DDQ}/2-0.3$	V
V_{IH}	Input HIGH Voltage		$V_{REF}+0.1$	$V_{DDQ}+0.3$	V
V_{IL}	Input LOW Voltage ^[12]		-0.3	$V_{REF}-0.1$	V
I_X	Input Load Current	$GND \leq V_I \leq V_{DDQ}$	-5	5	μA
I_{OZ}	Output Leakage Current	$GND \leq V_I \leq V_{DDQ}$, Output Disabled	-5	5	μA
V_{REF}	Input Reference Voltage	Typical value = 0.75V	0.68	0.9	V
I_{DD}	V_{DD} Operating Supply	$V_{DD} = \text{Max.}$, $I_{OUT} = 0 \text{ mA}$, $f = f_{MAX} = 1/t_{CYC}$	6.0 ns cycle, 167 MHz	550	mA
			7.5 ns cycle, 133 MHz	450	mA
			10 ns cycle, 100 MHz	330	mA
I_{SB1}	Automatic Power-Down Current	Max. V_{DD} , Both Ports De-selected, $V_{IN} \geq V_{IH}$ or $V_{IN} \leq V_{IL}$ $f = f_{MAX} = 1/t_{CYC}$, Inputs Static	6.0 ns cycle, 167 MHz	100	mA
			7.5 ns cycle, 133 MHz	80	mA
			10 ns cycle, 100 MHz	60	mA

Note:

12. Minimum voltage equals -2.0V for pulse duration less than 20 ns.
 13. T_A is the "Instant On" case temperature.

Switching Characteristics Over the Operating Range^[14, 15, 16, 17]

Parameters	Description	-167		-133		-100		Unit
		Min.	Max.	Min.	Max.	Min.	Max.	
t _{CYC}	K Clock and C Clock Cycle Time	6.0		7.5		10.0		ns
t _{KH}	Input Clock (K/ \bar{K} and C/ \bar{C}) HIGH	2.4		3.2		3.5		ns
t _{KL}	Input Clock (K/ \bar{K} and C/ \bar{C}) LOW	2.4		3.2		3.5		ns
t _{KHKH}	K/ \bar{K} Clock rise to \bar{K} / \bar{K} Clock rise and C/ \bar{C} to C/ \bar{C} rise (rising edge to rising edge)	2.7	3.3	3.4	4.1	4.4	5.4	ns
t _{KHCH}	K/ \bar{K} Clock rise to C/ \bar{C} clock rise (rising edge to rising edge)	0.0	2.0	0.0	2.5	0.0	3.0	ns
t _{CO}	C/ \bar{C} Clock rise (or K/ \bar{K} in single clock mode) to Data Valid ^[15]		2.5		3.0		3.0	ns
t _{DOH}	Data Output Hold After Output C/ \bar{C} clock Rise (Active to Active)	1.2		1.2		1.2		ns
Set-up Times								
t _{SA}	Address set-up to clock (K and \bar{K}) rise	0.7		0.8		1.0		ns
t _{SC}	Control set-up to clock (K and \bar{K}) rise (\overline{RPS} , \overline{WPS} , \overline{BWS}_0 , \overline{BWS}_1)	0.7		0.8		1.0		ns
t _{SD}	D _[17:0] set-up to clock (K and \bar{K}) rise	0.7		0.8		1.0		ns
Hold Times								
t _{HA}	Address Hold after clock (K and \bar{K}) rise	0.7		0.8		1.0		ns
t _{HC}	Control Hold after clock (K and \bar{K}) rise (\overline{RPS} , \overline{WPS} , \overline{BWS}_0 , \overline{BWS}_1)	0.7		0.8		1.0		ns
t _{HD}	D _[17:0] Hold after clock (K and \bar{K}) rise	0.7		0.8		1.0		ns
Output Times								
t _{CHZ}	Clock (C and \bar{C}) rise to High-Z (Active to High-Z) ^[15, 16]		2.5		3.0		3.0	ns
t _{CLZ}	Clock (C and \bar{C}) rise to Low-Z ^[15, 16]	1.2		1.2		1.2		ns

Note:

14. Unless otherwise noted, test conditions assume signal transition time of 2V/ns, timing reference levels of 0.75V, Vref=0.75V, RQ=250 Ω , V_{DDQ}=1.5V, input pulse levels of 0.25V to 1.25V, and output loading of the specified I_{OL}/I_{OH} and load capacitance shown in (a) of AC test loads.
15. t_{CHZ}, t_{CLZ}, are specified with a load capacitance of 5 pF as in part (b) of AC Test Loads. Transition is measured \pm 100 mV from steady-state voltage.
16. At any given voltage and temperature t_{CHZ} is less than t_{CLZ} and t_{CHZ} is less than t_{CO}.
17. Tested initially and after any design or process change that may affect these parameters.

Capacitance^[17]

Parameter	Description	Test Conditions	Max.	Unit
C_{IN}	Input Capacitance	$T_A = 25^\circ\text{C}$, $f = 1\text{ MHz}$, $V_{DD} = 2.5\text{V}$ $V_{DDQ} = 1.5\text{V}$	TBD	μF
C_{CLK}	Clock Input Capacitance		TBD	μF
C_O	Output Capacitance		TBD	μF

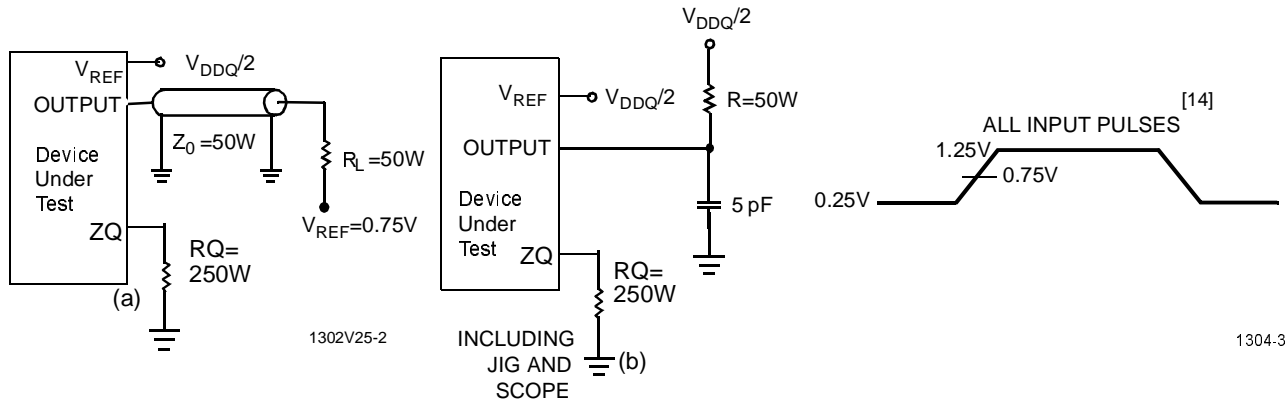

Switching Waveforms

Read/Deselect Sequence

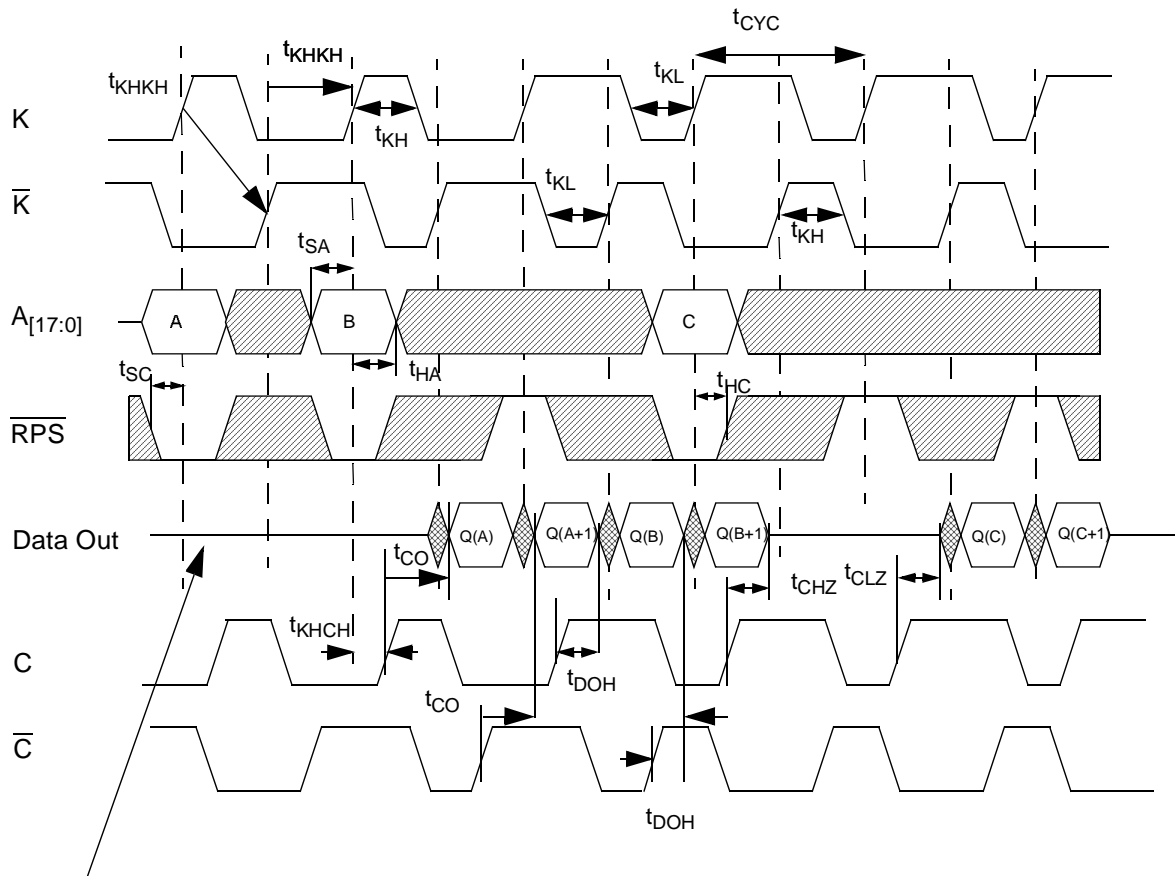

Device originally deselected.
Activity on the Write Port is unknown.

 = DON'T CARE  = UNDEFINED

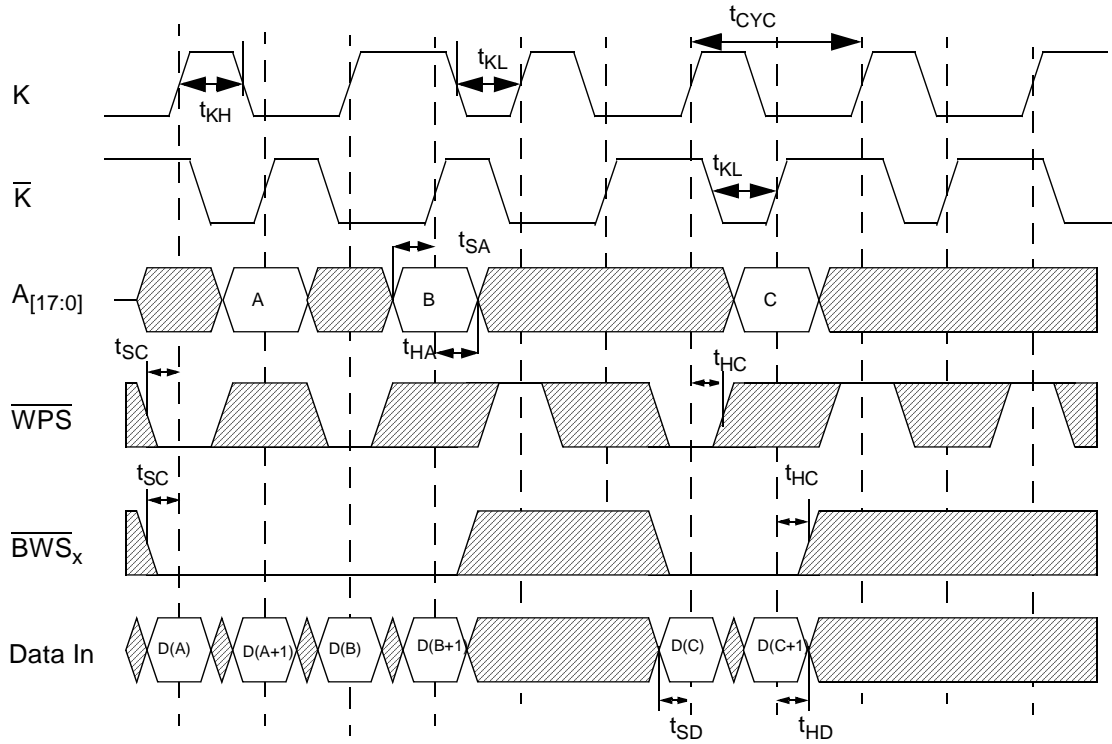
Switching Waveforms (continued)
Write/Deselect Sequence

\overline{BWS}_x is both \overline{BWS}_0 and \overline{BWS}_1

C and \bar{C} reference to Data Outputs and do not affect Writes. Activity on the Read Port is unknown.

\overline{BWS}_x LOW=Valid, Byte writes allowed, see Byte write table for details.

 = DON'T CARE  = UNDEFINED

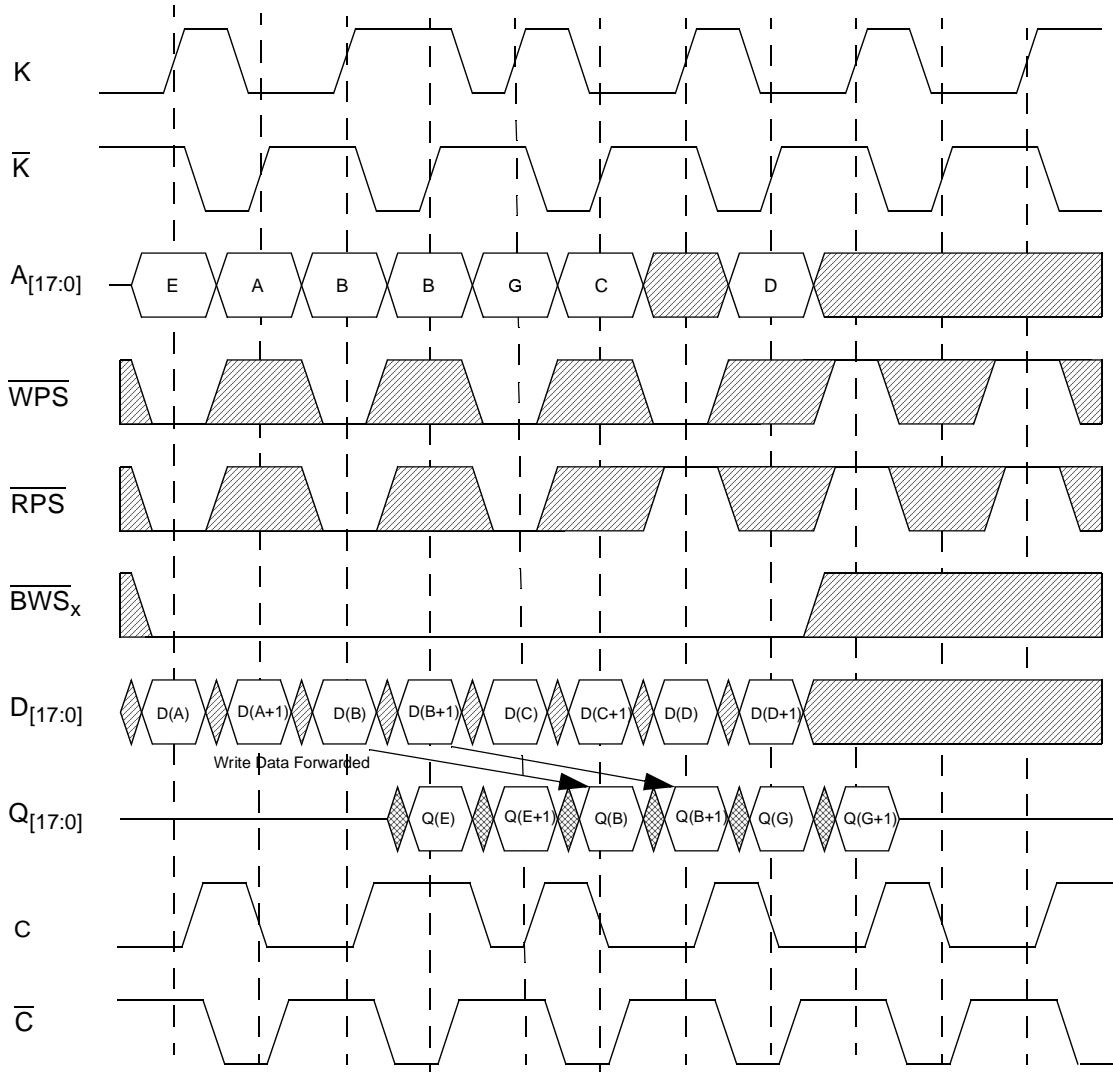
Switching Waveforms (continued)
Read/Write/Deselect Sequence

Read Port previously deselected.
 Any port select can deselect the port.
 $\overline{BWS}_{[1:0]}$ both assumed active.

 = DON'T CARE  = UNDEFINED

Ordering Information

Speed (MHz)	Ordering Code	Package Name	Package Type	Operating Range
167	CY7C1302V25-167BZC/	BA165A	13 x 15 mm FBGA	Commercial
133	CY7C1302V25-133BZC/			
100	CY7C1302V25-100BZC/			

Document #: 38-00924-**

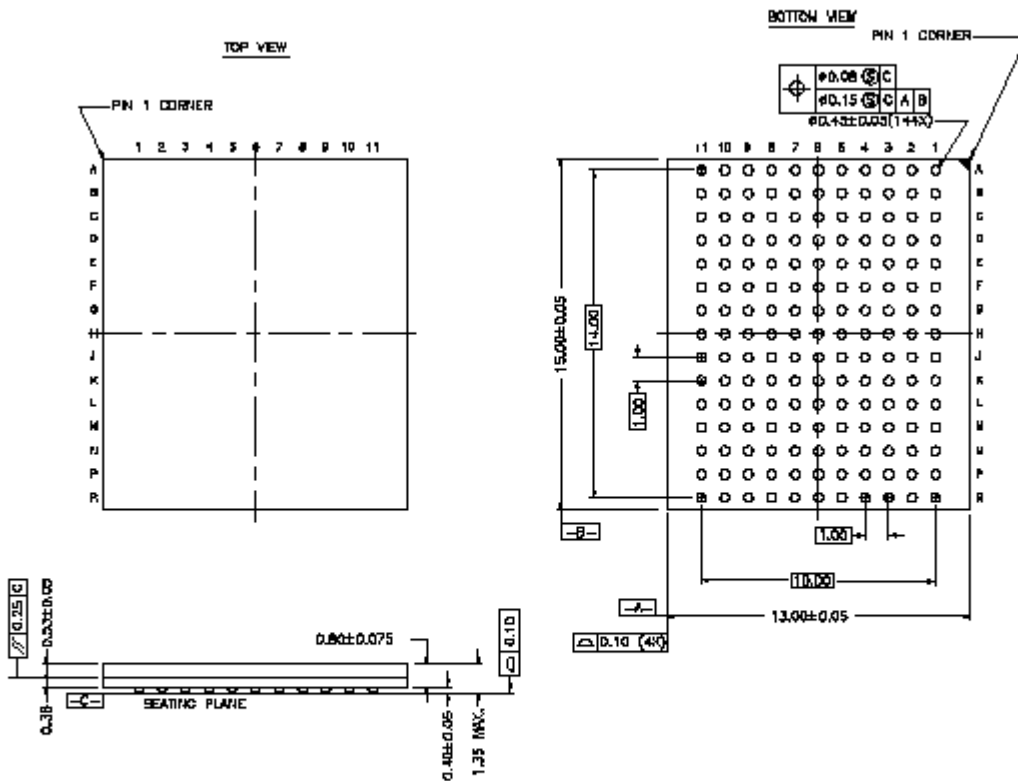
Package Diagram

* THE BALL DIAMETER IS DIFFERENT FROM JEDEC MO-205 (LOW PROFILE BGA FAMILY)