

TOSHIBA CMOS DIGITAL INTEGRATED CIRCUIT SILICON MONOLITHIC

**TC74VCX32FT****LOW-VOLTAGE QUAD 2-INPUT OR GATE  
WITH 3.6 V TOLERANT INPUTS AND OUTPUTS**

The TC74VCX32FT is a high performance CMOS 2-input OR gate. Designed for use in 1.8, 2.5 or 3.3 Volt systems, it achieves high speed operation while maintaining the CMOS low power dissipation.

It is also designed with over voltage tolerant inputs and outputs up to 3.6 V.

All inputs are equipped with protection circuits against static discharge.

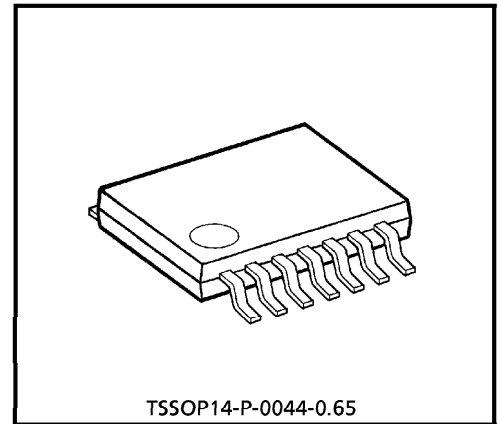

Weight : 0.06 g (Typ.)

**FEATURES**

- Low Voltage Operation:  $V_{CC} = 1.8\sim 3.6\text{ V}$
- High Speed Operation :  $t_{pd} = 2.8\text{ ns (max) at } V_{CC} = 3.0\sim 3.6\text{ V}$   
 $t_{pd} = 3.7\text{ ns (max) at } V_{CC} = 2.3\sim 2.7\text{ V}$   
 $t_{pd} = 7.4\text{ ns (max) at } V_{CC} = 1.8\text{ V}$
- 3.6 V Tolerant inputs and outputs.
- Output Current :  $I_{OH}/I_{OL} = \pm 24\text{ mA (min) at } V_{CC} = 3.0\text{ V}$   
 $I_{OH}/I_{OL} = \pm 18\text{ mA (min) at } V_{CC} = 2.3\text{ V}$   
 $I_{OH}/I_{OL} = \pm 6\text{ mA (min) at } V_{CC} = 1.8\text{ V}$
- Latch-up Performance :  $\pm 300\text{ mA}$
- ESD Performance : Human body model  $> \pm 2000\text{ V}$   
Machine model  $> \pm 200\text{ V}$
- Package : TSSOP  
(Thin Shrink Small Outline Package)
- Power down protection is provided on all inputs and outputs.

980910EBA1

- TOSHIBA is continually working to improve the quality and the reliability of its products. Nevertheless, semiconductor devices in general can malfunction or fail due to their inherent electrical sensitivity and vulnerability to physical stress. It is the responsibility of the buyer, when utilizing TOSHIBA products, to observe standards of safety, and to avoid situations in which a malfunction or failure of a TOSHIBA product could cause loss of human life, bodily injury or damage to property. In developing your designs, please ensure that TOSHIBA products are used within specified operating ranges as set forth in the most recent products specifications. Also, please keep in mind the precautions and conditions set forth in the TOSHIBA Semiconductor Reliability Handbook.
- The products described in this document are subject to the foreign exchange and foreign trade laws.
- The information contained herein is presented only as a guide for the applications of our products. No responsibility is assumed by TOSHIBA CORPORATION for any infringements of intellectual property or other rights of the third parties which may result from its use. No license is granted by implication or otherwise under any intellectual property or other rights of TOSHIBA CORPORATION or others.
- The information contained herein is subject to change without notice.

**PIN ASSIGNMENT**

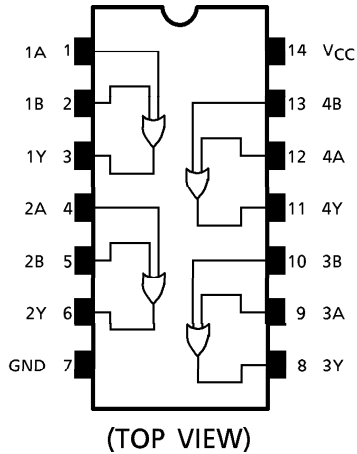

**IEC LOGIC SYMBOL**

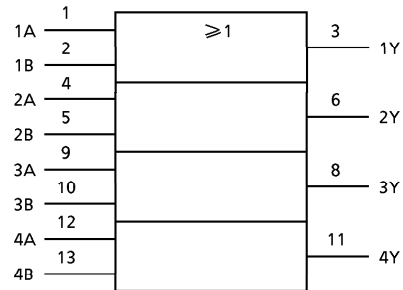

**TRUTH TABLE**

INPUTS		OUTPUTS
A	B	Y
L	L	L
L	H	H
H	L	H
H	H	H

**MAXIMUM RATINGS**

PARAMETER	SYMBOL	RATING	UNIT
Power Supply Voltage	$V_{CC}$	-0.5~4.6	V
DC Input Voltage	$V_{IN}$	-0.5~4.6	V
DC Output Voltage	$V_{OUT}$	-0.5~4.6 (Note 1)	V
		-0.5~ $V_{CC} + 0.5$ (Note 2)	
Input Diode Current	$I_{IK}$	-50	mA
Output Diode Current	$I_{OK}$	±50 (Note 3)	mA
DC Output Current	$I_{OUT}$	±50	mA
Power Dissipation	$P_D$	180	mW
DC $V_{CC}$ /Ground Current	$I_{CC}/I_{GND}$	±100	mA
Storage Temperature	$T_{stg}$	-65~150	°C

(Note 1) :  $V_{CC} = 0V$

(Note 2) : High or Low State.  $I_{OUT}$  absolute maximum rating must be observed.

(Note 3) :  $V_{OUT} < GND, V_{OUT} > V_{CC}$

**RECOMMENDED OPERATING RANGE**

PARAMETER	SYMBOL	RATING	UNIT
Supply Voltage	V <sub>CC</sub>	1.8~3.6	V
		1.2~3.6 (Note 4)	
Input Voltage	V <sub>IN</sub>	-0.3~3.6	V
Output Voltage	V <sub>OUT</sub>	0~3.6 (Note 5)	V
		0~V <sub>CC</sub> (Note 6)	
Output Current	I <sub>OH</sub> /I <sub>OL</sub>	±24 (Note 7)	mA
		±18 (Note 8)	
		±6 (Note 9)	
Operating Temperature	T <sub>opr</sub>	-40~85	°C
Input Rise And Fall Time	dt/dv	0~10 (Note 10)	ns/V

- (Note 4) : Data Retention Only
- (Note 5) : V<sub>CC</sub> = 0V
- (Note 6) : High or Low State
- (Note 7) : V<sub>CC</sub> = 3.0~3.6 V
- (Note 8) : V<sub>CC</sub> = 2.3~2.7 V
- (Note 9) : V<sub>CC</sub> = 1.8 V
- (Note 10) : V<sub>IN</sub> = 0.8~2.0 V, V<sub>CC</sub> = 3.0 V

**ELECTRICAL CHARACTERISTICS**

DC characteristics (T<sub>a</sub> = -40~85°C, 2.7 V < V<sub>CC</sub> ≤ 3.6 V)

PARAMETER	SYMBOL	TEST CONDITION	V <sub>CC</sub> (V)	Min	Max	UNIT	
Input Voltage	"H" Level	V <sub>IH</sub>	2.7~3.6	2.0	—	V	
	"L" Level	V <sub>IL</sub>	2.7~3.6	—	0.8		
Output Voltage	"H" Level	V <sub>OH</sub>	V <sub>IN</sub> = V <sub>IH</sub> or V <sub>IL</sub>	I <sub>OH</sub> = -100 μA	2.7~3.6	V <sub>CC</sub> - 0.2	V
				I <sub>OH</sub> = -12 mA	2.7	2.2	
				I <sub>OH</sub> = -18 mA	3.0	2.4	
				I <sub>OH</sub> = -24 mA	3.0	2.2	
	"L" Level	V <sub>OL</sub>	V <sub>IN</sub> = V <sub>IL</sub>	I <sub>OL</sub> = 100 μA	2.7~3.6	—	0.2
				I <sub>OL</sub> = 12 mA	2.7	—	0.4
				I <sub>OL</sub> = 18 mA	3.0	—	0.4
				I <sub>OL</sub> = 24 mA	3.0	—	0.55
Input Leakage Current	I <sub>IN</sub>	V <sub>IN</sub> = 0~3.6 V	2.7~3.6	—	±5.0	μA	
Power Off Leakage Current	I <sub>OFF</sub>	V <sub>IN</sub> , V <sub>OUT</sub> = 0~3.6 V	0	—	10.0	μA	
Quiescent Supply Current	I <sub>CC</sub>	V <sub>IN</sub> = V <sub>CC</sub> or GND	2.7~3.6	—	20.0	μA	
		V <sub>CC</sub> ≤ V <sub>IN</sub> ≤ 3.6 V	2.7~3.6	—	±20.0		
Increase In I <sub>CC</sub> Per Input	ΔI <sub>CC</sub>	V <sub>IH</sub> = V <sub>CC</sub> - 0.6 V	2.7~3.6	—	750	μA	

**ELECTRICAL CHARACTERISTICS**

DC characteristics (Ta = -40~85°C, 2.3 V ≤ V<sub>CC</sub> ≤ 2.7 V)

PARAMETER		SYMBOL	TEST CONDITION		V <sub>CC</sub> (V)	Min	Max	UNIT
Input Voltage	"H" Level	V <sub>IH</sub>			2.3~2.7	1.6	—	V
	"L" Level	V <sub>IL</sub>			2.3~2.7	—	0.7	
Output Voltage	"H" Level	V <sub>OH</sub>	V <sub>IN</sub> = V <sub>IH</sub> or V <sub>IL</sub>	I <sub>OH</sub> = -100 μA	2.3~2.7	V <sub>CC</sub> - 0.2	—	V
				I <sub>OH</sub> = -6 mA	2.3	2.0	—	
				I <sub>OH</sub> = -12 mA	2.3	1.8	—	
				I <sub>OH</sub> = -18 mA	2.3	1.7	—	
	"L" Level	V <sub>OL</sub>	V <sub>IN</sub> = V <sub>IL</sub>	I <sub>OL</sub> = 100 μA	2.3~2.7	—	0.2	
				I <sub>OL</sub> = 12 mA	2.3	—	0.4	
I <sub>OL</sub> = 18 mA				2.3	—	0.6		
Input Leakage Current		I <sub>IN</sub>	V <sub>IN</sub> = 0~3.6 V		2.3~2.7	—	± 5.0	μA
Power Off Leakage Current		I <sub>OFF</sub>	V <sub>IN</sub> , V <sub>OUT</sub> = 0~3.6 V		0	—	10.0	μA
Quiescent Supply Current		I <sub>CC</sub>	V <sub>IN</sub> = V <sub>CC</sub> or GND		2.3~2.7	—	20.0	μA
			V <sub>CC</sub> ≤ V <sub>IN</sub> ≤ 3.6V <sub>CC</sub>		2.3~2.7	—	± 20.0	

**ELECTRICAL CHARACTERISTICS**

DC characteristics (Ta = -40~85°C, 1.8 V ≤ VCC < 2.3 V)

PARAMETER		SYMBOL	TEST CONDITION		VCC (V)	Min	Max	UNIT
					1.8~2.3			
Input Voltage	"H" Level	V <sub>IH</sub>			1.8~2.3	0.7 × V <sub>CC</sub>	—	V
	"L" Level	V <sub>IL</sub>			1.8~2.3	—	0.2 × V <sub>CC</sub>	
Output Voltage	"H" Level	V <sub>OH</sub>	V <sub>IN</sub> = V <sub>IH</sub> or V <sub>IL</sub>	I <sub>OH</sub> = -100 μA	1.8	V <sub>CC</sub> - 0.2	—	V
				I <sub>OH</sub> = -6 mA	1.8	1.4	—	
	"L" Level	V <sub>OL</sub>	V <sub>IN</sub> = V <sub>IL</sub>	I <sub>OL</sub> = 100 μA	1.8	—	0.2	
				I <sub>OL</sub> = 6 mA	1.8	—	0.3	
Input Leakage Current		I <sub>IN</sub>	V <sub>IN</sub> = 0~3.6 V		1.8	—	± 5.0	μA
Power Off Leakage Current		I <sub>OFF</sub>	V <sub>IN</sub> , V <sub>OUT</sub> = 0~3.6 V		0	—	10.0	μA
Quiescent Supply Current		I <sub>CC</sub>	V <sub>IN</sub> = V <sub>CC</sub> or GND		1.8	—	20.0	μA
			V <sub>CC</sub> ≤ V <sub>IN</sub> ≤ 3.6 V		1.8	—	± 20.0	

AC characteristics (Ta = -40~85°C, Input t<sub>r</sub> = t<sub>f</sub> = 2.0 ns, C<sub>L</sub> = 30 pF, R<sub>L</sub> = 500 Ω)

PARAMETER		SYMBOL	TEST CONDITION		VCC (V)	Min	Max	UNIT
					1.8			
Propagation Delay Time	t <sub>pLH</sub> t <sub>pHL</sub>	(Fig.1, 2)			1.8	1.0	7.4	ns
					2.5 ± 0.2	0.8	3.7	
					3.3 ± 0.3	0.6	2.8	
Output To Output Skew	t <sub>osLH</sub> t <sub>osHL</sub>	(Note 11)			1.8	—	0.5	ns
					2.5 ± 0.2	—	0.5	
					3.3 ± 0.3	—	0.5	

For C<sub>L</sub> = 50 pF, add approximately 300 ps to the AC maximum specification.

(Note 11) : Parameter guaranteed by design.  
 (t<sub>osLH</sub> = |t<sub>pLHm</sub> - t<sub>pLHn</sub>|, t<sub>osHL</sub> = |t<sub>pHLm</sub> - t<sub>pHLn</sub>|)

Dynamic switching characteristics (Ta = 25°C, Input tr = tf = 2.0 ns, CL = 30 pF)

PARAMETER	SYMBOL	TEST CONDITION	VCC (V)	Typ.	UNIT
Quiet Output Maximum Dynamic VOL	VOLP	VIH = 1.8 V, VIL = 0 V (Note 12)	1.8	0.25	V
		VIH = 2.5 V, VIL = 0 V (Note 12)	2.5	0.6	
		VIH = 3.3 V, VIL = 0 V (Note 12)	3.3	0.8	
Quiet Output Minimum Dynamic VOL	VOLV	VIH = 1.8 V, VIL = 0 V (Note 12)	1.8	-0.25	V
		VIH = 2.5 V, VIL = 0 V (Note 12)	2.5	-0.6	
		VIH = 3.3 V, VIL = 0 V (Note 12)	3.3	-0.8	
Quiet Output Minimum Dynamic VOH	VOHV	VIH = 1.8 V, VIL = 0 V (Note 12)	1.8	1.5	V
		VIH = 2.5 V, VIL = 0 V (Note 12)	2.5	1.9	
		VIH = 3.3 V, VIL = 0 V (Note 12)	3.3	2.2	

(Note 12) : Parameter guaranteed by design.

Capacitive characteristics (Ta = 25°C)

PARAMETER	SYMBOL	TEST CONDITION	VCC (V)	Typ.	UNIT
Input Capacitance	CIN		1.8, 2.5, 3.3	6	pF
Power Dissipation Capacitance	CPD	fIN = 10 MHz (Note 13)	1.8, 2.5, 3.3	20	pF

(Note 13) : CPD is defined as the value of the internal equivalent capacitance which is calculated from the operating current consumption without load.

Average operating current can be obtained by the equation :

$$I_{CC(opr.)} = C_{PD} \cdot V_{CC} \cdot f_{IN} + I_{CC}/4 \text{ (per gate)}$$

TEST CIRCUIT

Fig.1

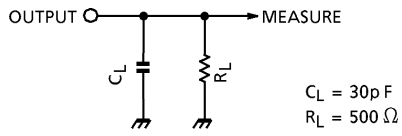

AC WAVEFORM

Fig.2  $t_{pLH}$ ,  $t_{pHL}$

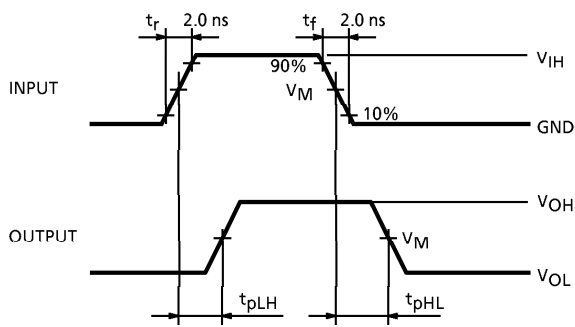

SYMBOL	$V_{CC}$		
	$3.3 \pm 0.3\text{ V}$	$2.5 \pm 0.2\text{ V}$	1.8 V
$V_{IH}$	2.7 V	$V_{CC}$	$V_{CC}$
$V_M$	1.5 V	$V_{CC}/2$	$V_{CC}/2$

**PACKAGE DIMENSIONS**  
TSSOP14-P-0044-0.65

Unit : mm

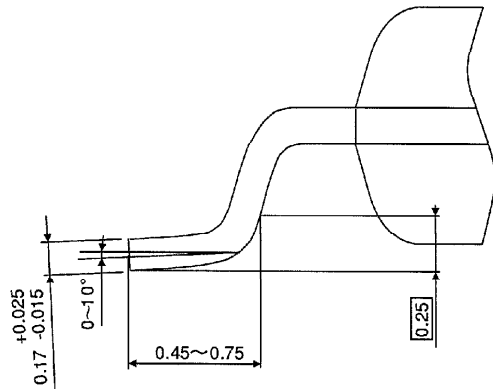
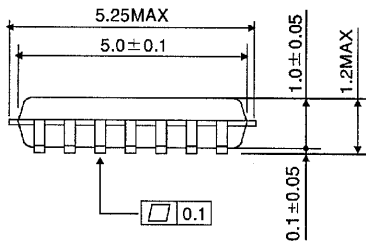
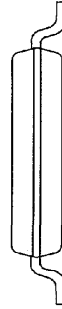
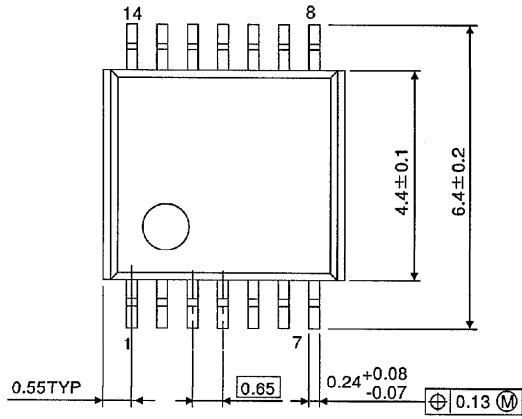

Weight : 0.06 g (Typ.)