

MF1050S-1

FOR DIGITAL MOBILE TELEPHONE, Rx

MF1050S-1

DESCRIPTION

This SAW filter for the receiving RF circuit of digital mobile communication equipment operating at 1477 MHz ~ 1501 MHz.

FEATURES

1. SMD package insures small size, lightweight.
2. Adjustment free.
3. Low insertion loss and high stop band attenuation.
4. Wide and sharp passband characteristics.
5. High stability and reliability.
6. Designed for reflow solderings.

APPLICATION

- Digital mobile cellular telephone
- Portable digital cellular telephone
- Wireless equipment

ELECTRICAL PERFORMANCE

Parameter	MF1050S-1			Units
	Min	Typ	Max	
PASSBAND FREQUENCY	1477 – 1501			MHz
PASSBAND CHARACTERISTICS				
Insertion Loss		2.2	2.8	dB
Ripple		0.8	1.5	dBp-p
VSWR		1.8	2.5	
STOPBAND ATTENUATION				
0 – 1050 MHz	30	35		dB
1050 – 1380 MHz	20	23		dB
1429 – 1453 MHz	5	10		dB
1607 – 1631 MHz	30	35		dB
1737 – 1761 MHz	30	33		dB
1761 – 3000 MHz	20	23		dB

MAXIMUM RATINGS

Rating	Value	Unit
Input Power	40	mW
Operating Temperature Range	-20 to 75	°C
Storage Temperature Range	-30 to 85	°C

PACKAGE OUTLINE DIMENSIONS

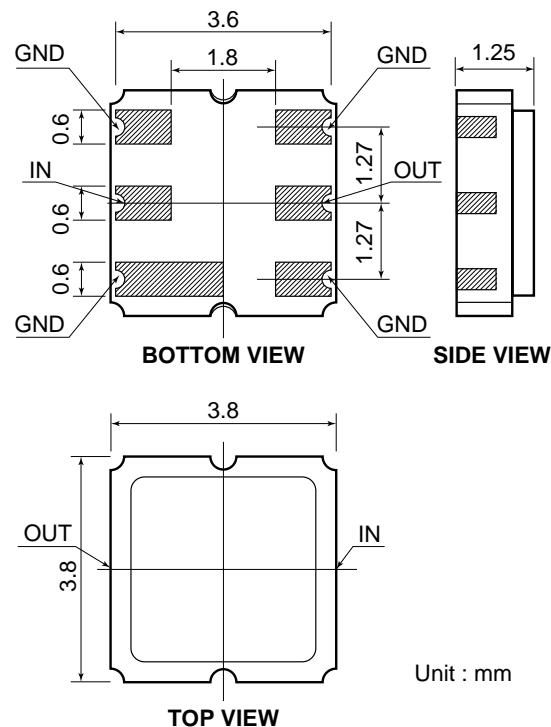

DIMENSIONS ARE IN MILLIMETERS
±0.2 UNLESS OTHERWISE SPECIFIED

MF1050S-1 TYPICAL CHARACTERISTICS

