

# 16-bit Proprietary Microcontroller

CMOS

## F<sup>2</sup>MC-16F MB90F244

### MB90F244

#### ■ DESCRIPTION

The MB90F244 is a 16-bit microcontroller optimized for applications in mechatronics such as HDD units. The architecture of the MB90F244 is based on the MB90242A, and embedded with a 128-Kbyte flash memory.

The instruction set is based on the AT architecture of the F<sup>2</sup>MC\* family, with additional high-level language supporting instruction, expanded addressing modes, enhanced multiplication and division instructions, and improved bit processing instructions. In addition, long-word data can now be processed due to the inclusion of a 32-bit accumulator.

The MB90F244 includes a variety of peripherals on chip, such as the device is equipped with 8-channel 8/10-bit A/D converter, UART, 3-channel 16-bit reload timers, 1-channel 16-bit timer, 4-channel 16-bit input capture and 4-channel DTP/external interrupts.

Differences between the MB90F244 and MB90F243 to meet the 3.3 V  $\pm$ 0.3 V power supply voltage are that the power consumption of the MB90F244 is about 10% less than that of the MB90F243 and the operating frequency of the MB90F244 is up to 50 MHz from 32 MHz of the MB90F243.

\* : F<sup>2</sup>MC stands for FUJITSU Flexible Microcontroller.

#### ■ PACKAGE

80-pin Plastic TQFP

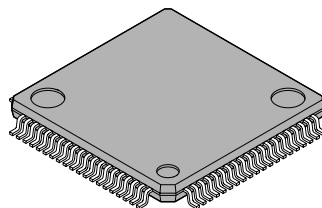

(FPT-80P-M15)

## ■ FEATURES

- Minimum execution time (target): 40.0 ns at 50 MHz oscillation (3.3 V  $\pm$ 0.3 V)
- Instruction set optimized for controller applications
  - Variety of data types: bit, byte, word, long-word
  - Expanded addressing modes: 25 types
  - High coding efficiency
  - Improvement of high-precision arithmetic operations through use of 32-bit accumulator
  - Enhanced multiplication and division instructions (signed arithmetic operations)
- Instruction set supports high-level language (C language) and multitasking
  - Inclusion of system stack pointer
  - Variety of pointers
  - High instruction set symmetry
  - Barrel shift instruction
  - Stack check function
- Improved execution speed: 8-byte queue
- Powerful interrupt functions
  - Interrupt processing time: 0.64  $\mu$ s at 50 MHz oscillation
  - Priority levels: 8 levels (programmable)
  - External interrupt inputs: 4 channels
- Automatic transfer function independent of CPU
  - Extended intelligent I/O service: Max.15 channels
- 128-Kbyte flash memory
  - Access time (min.) : 80 ns
  - Sector structure of 16K + 512  $\times$  2 + 7K + 8K + 32K + 64K
  - Program/erase operations from both EPROM programmer and CPU through built-in flash memory interface circuit
  - Built-in programming booster circuit for flash memory
- Internal RAM: 1.152 kbyte
  - According to mode settings, data stored on RAM can be executed as CPU instructions.
- General-purpose ports: Max. 63 channels (single-chip mode)  
Max. 38 channels (external bus mode)
- 18-bit timebase timer
- Watchdog timer
- UART: 8 bits  $\times$  1 channel
- 8/16-bit I/O simple serial interface (max. 12.5 Mbps): 1 channel
- 8/10-bit A/D converter: Analog inputs: 8 channels
  - Resolution: 10 bits (switchable to 8 bits/10 bits)
  - Conversion time: Min. 1  $\mu$ s
  - Conversion result store register: 4 channels
- 16-bit I/O timer
  - 16-bit free-run timer: 1 channel (operating clock: 0.16  $\mu$ s)
  - 16-bit input capture: 4 channels
- 16-bit reload timer: 3 channels
- Low-power consumption modes
  - Sleep mode
  - Stop mode
  - Hardware standby mode
- Packages: TQFP-80 (FPT-80P-M15)  
(For more information about the package, see section “■ Package Dimensions.”)

(Continued)

*(Continued)*

- PLL clock multiple function
- CMOS technology
- Power supply voltage: 3.3 V  $\pm$ 0.3 V or 5.0 V  $\pm$ 0.5 V  
(Varies with conditions such as the operating frequency. See section  
“■ Electrical Characteristics.”)

# MB90F244

## ■ PIN ASSIGNMENT

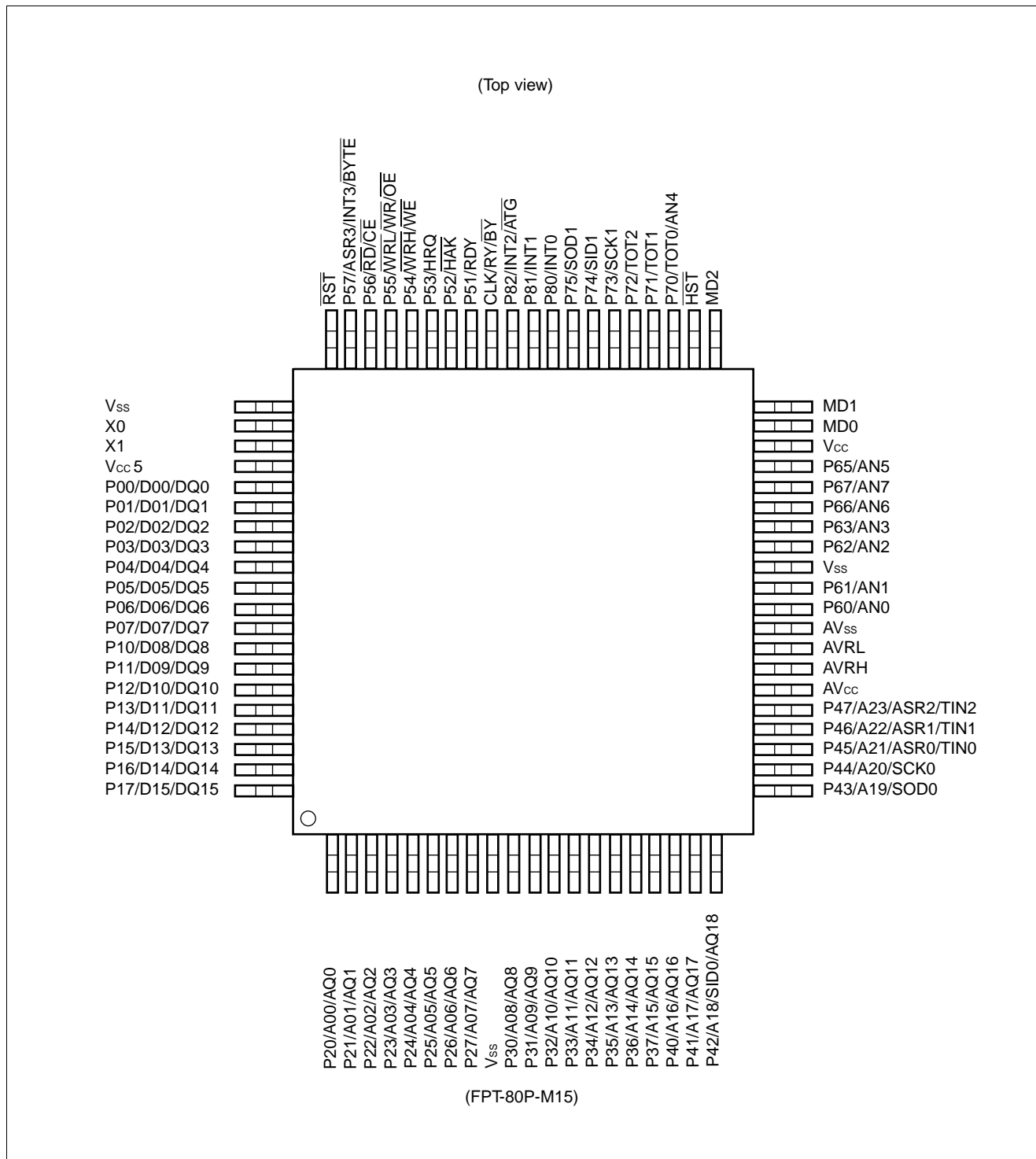

## ■ PIN DESCRIPTION

Pin no. TQFP-80*	Pin name	Circuit type	Function
62	X0	A	Crystal oscillator pins (50 MHz)
63	X1		
39 to 41	MD0 to MD2	C	Operating mode selection input pins Connect directly to V <sub>CC5</sub> or V <sub>SS</sub> . In the flash memory mode, these pins are set to be V <sub>ID</sub> (= 12.0 V) input pins by performing a proper operation.
60	$\overline{\text{RST}}$	B	External reset request input pin
42	$\overline{\text{HST}}$	D	Hardware standby input pin
65 to 72	P00 to P07	E	General-purpose I/O port
	D00 to D07		I/O pins for the lower 8 bits of the external data bus
	DQ0 to DQ7		Data I/O pins for each operation command This function is valid in the flash memory mode.
73 to 80	P10 to P17	E	General-purpose I/O port This function is valid when the external bus 8-bit mode.
	D08 to D15		I/O pins for the upper 8 bits of the external data bus This function is valid when 16-bit bus mode.
	DQ8 to DQ15		Data I/O pins for each operation command This function is valid in the flash memory mode.
1 to 8	P20 to P27	F	General-purpose I/O port
	A00 to A07		Output pins for the medium 8 bits of the external address bus
	AQ0 to AQ7		Address input pins for each operation command This function is valid in the flash memory mode.
10 to 17	P30 to P37	F	General-purpose I/O port This function is valid when the corresponding bit of the middle address control register specification is "port".
	A08 to A15		Output pins for the medium 8 bits of the external address bus This function is valid when the corresponding bit of the middle address control register specification is "port".
	AQ8 to AQ15		Address input pins for each operation command This function is valid in the flash memory mode.
18	P40	F	General-purpose I/O port This function is valid when the corresponding bit of the upper address control register specification is "port".
	A16		External address bus output pin of the bit 16 This function is valid when the corresponding bit of the upper address control register specification is "address".
	AQ16		Address input pin for each operation command This function is valid in the flash memory mode.

\*: FPT-80P-M15

(Continued)

# MB90F244

Pin no. TQFP-80*	Pin name	Circuit type	Function
19	P41	F	General-purpose I/O port This function is valid when the upper address control register specification is "port".
	A17		External address bus output pin of the bit 17 This function is valid when the corresponding bit of the upper address control register specification is "address".
	AQ17		Address input pin for each operation command This function is valid in the flash memory mode.
20	P42	F	General-purpose I/O port This function is valid when the corresponding bit of the upper address control register specification is "port".
	A18		External address bus output pin of the bit 18 This function is valid when the corresponding bit of the upper address control register specification is "address".
	SID0		UART #0 data input pin During UART #0 input operations, these inputs may be used at any time; therefore, it is necessary to stop output by other functions on this pin, except when using them for output deliberately.
	AQ18		Address input pin for each operation command This function is valid in the flash memory mode.
21	P43	G	General-purpose I/O port This function is valid when the UART #0 data output is disabled and the corresponding bit of the upper address control register specification is "port".
	A19		External address bus output pin of the bit 19 This function is valid when the UART #0 data output is disabled and the corresponding bit of the upper address control register specification is "address".
	SOD0		UART #0 data output pin This function is valid when the UART #0 data output is enabled.
22	P44	G	General-purpose I/O port This function is valid when the UART #0 clock output is disabled and the corresponding bit of the upper address control register specification is "port".
	A20		External address bus output pin of the bit 20 This function is valid when the UART #0 clock output is disabled and the corresponding bit of the upper address control register specification is "address".
	SCK0		UART #0 clock I/O pin

\*: FPT-80P-M15

(Continued)

Pin no. TQFP-80*	Pin name	Circuit type	Function
23	P45	G	General-purpose I/O port This function is valid when the corresponding bit of the upper address control register specification is "port".
	A21		External address bus output pin of the bit 21 This function is valid when the corresponding bit of the upper address control register specification is "address".
	ASR0		16-bit input capture #0 data input pin During 16-bit input capture #0 input operations, these inputs may be used at any time; therefore, it is necessary to stop output by other functions on this pin, except when using them for output deliberately.
	TIN0		16-bit timer #0 data input pin During 16-bit timer #0 input operations, these inputs may be used at any time; therefore, it is necessary to stop output by other functions on this pin, except when using them for output deliberately.
24	P46	G	General-purpose I/O port This function is valid when the corresponding bit of the upper address control register specification is "port".
	A22		External address bus output pin of the bit 22 This function is valid when the corresponding bit of the upper address control register specification is "address".
	ASR1		16-bit input capture #1 data input pin During 16-bit input capture #1 input operations, these inputs may be used at any time; therefore, it is necessary to stop output by other functions on this pin, except when using them for output deliberately.
	TIN1		16-bit timer #1 data input pin During 16-bit timer #1 input operations, these inputs may be used at any time; therefore, it is necessary to stop output by other functions on this pin, except when using them for output deliberately.
25	P47	G	General-purpose I/O port This function is valid when the corresponding bit of the upper address control register specification is "port".
	A23		External address bus output pin for the bit 23 This function is valid when the corresponding bit of the upper address control register specification is "address".
	ASR2		16-bit input capture #2 data input pin During 16-bit input capture #2 input operations, these inputs may be used at any time; therefore, it is necessary to stop output by other functions on this pin, except when using them for output deliberately.
	TIN2		16-bit timer #2 data input pin During 16-bit timer #2 input operations, these inputs may be used at any time; therefore, it is necessary to stop output by other functions on this pin, except when using them for output deliberately.

\*: FPT-80P-M15

(Continued)

# MB90F244

Pin no. TQFP-80*	Pin name	Circuit type	Function
53	P51	H	General-purpose I/O port This function is valid when the ready function is disabled.
	RDY		Ready input pin This function is valid when the ready function is enabled.
54	P52	H	General-purpose I/O port This function is valid when the hold function is disabled.
	$\overline{\text{HAK}}$		Hold acknowledge output pin This function is valid when the hold function is enabled.
55	P53	H	General-purpose I/O port This function is valid when the hold function is disabled.
	HRQ		Hold request input pin This function is valid and when the hold function is enabled.
56	P54	F	General-purpose I/O port This function is valid in external bus 8-bit mode, or when $\overline{\text{WRH}}$ pin output is disabled.
	$\overline{\text{WRH}}$		Write strobe output pin for the upper 8 bits of the data bus This function is valid in modes where the external bus 16-bit mode is enabled, and $\overline{\text{WRH}}$ pin output is enabled.
	$\overline{\text{WE}}$		Write enable input pin This function is valid in the flash memory mode.
57	P55	F	General-purpose I/O port This function is valid when $\overline{\text{WRL}}$ pin output is disabled.
	$\overline{\text{WRL}} / \overline{\text{WR}}$		Write strobe output pin for the lower 8 bits of the data bus This function is valid $\overline{\text{WRL}}$ pin output is enabled.
	$\overline{\text{OE}}$		Output enable input pin for each operation command This function is valid in the flash memory mode.
58	P56	F	General-purpose I/O port
	$\overline{\text{RD}}$		Read strobe output pin for the data bus
	$\overline{\text{CE}}$		Chip enable input pin for each operation command This function is valid in the flash memory mode.
59	P57	F	General-purpose I/O port
	ASR3		16-bit input capture #3 data input pin During 16-bit input capture #3 input operations, these inputs may be used at any time; therefore, it is necessary to stop output by other functions on this pin, except when using them for output deliberately.
	INT3		DTP/external interrupt #3 data input pin During DTP/external interrupt #3 input operations, these inputs may be used at any time; therefore, it is necessary to stop output by other functions on this pin, except when using them for output deliberately.
	$\overline{\text{BYTE}}$		Byte access control input pin This function is valid in the flash memory mode.

\*: FPT-80P-M15

(Continued)



Pin no. TQFP-80*	Pin name	Circuit type	Function
30, 31, 33, 34, 35, 36, 37	P60, P61, P62, P63, P66, P67, P65	I	N-ch open-drain type I/O ports When bits corresponding to the ADER are set to "0", reading instructions other than the read-modify-write group returns the pin level. The value written on the data register is output to this pin directly.
	AN0, AN1, AN2, AN3, AN6, AN7, AN5		8/10-bit A/D converter analog input pins Use this function after setting bits corresponding to the ADER to "1" and setting corresponding bits of the data register to "1".
43	P70	J	General-purpose I/O port This function is valid when the bit corresponded to ADER is set to "0" and also the output of 16-bit timer #0 is disabled.
	TOT0		16-bit timer output pin This function is valid when the bit corresponded to ADER is set to "0" and also the output of 16-bit timer #0 is enabled.
	AN4		8/10-bit AD converter analog input pin This function can be used when the bit corresponded to ADER is set to "1" and also the bit corresponded to the data register is set to "1".
44, 45	P70, P72	G	General-purpose I/O port This function is valid when the reload timer #1, and #2 output is disabled.
	TOT1, TOT2		16-bit timer output pins This function is valid when the 16-bit timer #1, and #2 output is enabled.
46	P73	G	General-purpose I/O port This function is valid when the SSI #1 clock output is disabled.
	SCK1		SSI #1 clock output I/O pin
47	P74	G	General-purpose I/O port This function is always valid.
	SID1		SSI #1 data input pin During SSI #1 input operations, these inputs may be used at any time; therefore, it is necessary to stop output by other functions on this pin, except when using them for output deliberately.
48	P75	G	General-purpose I/O port This function is valid when the SSI #1 data output is disabled.
	SOD1		SSI #1 data output pin This function is valid when the SSI #1 data output is disabled.

\*: FPT-80P-M15

(Continued)

# MB90F244

(Continued)

Pin no. TQFP-80*	Pin name	Circuit type	Function
49, 50	P80, P81	G	General-purpose I/O port This function is always valid.
	INT0, INT1		DTP/external interrupt input pin When external interrupts are enabled, these inputs may be used at any time; therefore, it is necessary to stop output by other functions on this pin, except when using them for output deliberately.
51	P82	G	General-purpose I/O port This function is always valid.
	INT2		DTP/external interrupt input pin When external interrupts are enabled, these inputs may be used at any time; therefore, it is necessary to stop output by other functions on this pin, except when using them for output deliberately. Because an input to this pin is clamped to Low when the CPU stops, use INT0 or INT1 to wake up the system from the stop mode.
	$\overline{ATG}$		8/10-bit A/D converter trigger input pin When 8/10-bit A/D converter is waiting for activation, this input may be used at any time; therefore, it is necessary to stop output by other functions on this pin, except when using it for output deliberately.
52	CLK	G	CLK output pin
	$\overline{RY/BY}$		Open-drain pin output ready/busy signal in the program deleting operation This function is valid in the flash memory mode.
38	V <sub>cc</sub>	Power supply	Digital circuit power supply pin
64	V <sub>cc5</sub>	Power supply	Power supply voltage (5.0 V) input pin for flash memory
9, 32, 61	V <sub>ss</sub>	Power supply	Digital circuit power supply (GND) pin
26	AV <sub>cc</sub>	Power supply	Analog circuit power supply pin This power supply must only be turned on or off when electric potential of AV <sub>cc</sub> or greater is applied to V <sub>cc</sub> .
27	AVRH	Power supply	8/10-bit A/D converter external reference voltage input pin This pin must only be turned on or off when electric potential of AVRH or greater is applied to AV <sub>cc</sub> .
28	AVRL	Power supply	8/10-bit A/D converter external reference voltage input pin
29	AV <sub>ss</sub>	Power supply	Analog circuit power supply (GND) pin

\*: FPT-80P-M15

## ■ I/O CIRCUIT TYPE

Type	Circuit	Remarks
A		<ul style="list-style-type: none"> <li>• 50 MHz</li> <li>• Oscillation feedback resistor: Approximately 1 MΩ</li> </ul>
B		<ul style="list-style-type: none"> <li>• CMOS-level hysteresis input (without standby control)</li> <li>• Pull-up resistor: Approximately 50 kΩ</li> </ul>
C		<ul style="list-style-type: none"> <li>• CMOS-level input</li> <li>• High voltage control for flash memory testing</li> </ul>
D		<ul style="list-style-type: none"> <li>• CMOS-level hysteresis input (without standby control)</li> </ul>

(Continued)

# MB90F244

(Continued)

Type	Circuit	Remarks
E	<p>Diffusion resistor</p> <p>Flash memory mode</p> <p>Standby control signal</p> <p>Digital output</p> <p>Digital output</p> <p>Flash memory input</p> <p>Digital input</p> <p>TTL</p> <p>TTL</p>	<ul style="list-style-type: none"> <li>• CMOS-level output</li> <li>• TTL-level input (with standby control)</li> </ul>
F	<p>Diffusion resistor</p> <p>Flash memory mode</p> <p>Standby control signal</p> <p>Digital output</p> <p>Digital output</p> <p>Flash memory input</p> <p>Digital input signal</p> <p>TTL</p> <p>CMOS</p>	<ul style="list-style-type: none"> <li>• CMOS-level output</li> <li>• CMOS-level hysteresis input</li> <li>• TTL-level input (flash memory mode) (with standby control)</li> </ul>
G	<p>Diffusion resistor</p> <p>Standby control signal</p> <p>Digital output</p> <p>Digital output</p> <p>Digital input signal</p> <p>CMOS</p>	<ul style="list-style-type: none"> <li>• CMOS-level output</li> <li>• CMOS-level hysteresis input (with standby control)</li> </ul>
H	<p>Diffused resistor</p> <p>Standby control signal</p> <p>Digital output</p> <p>Digital output</p> <p>Digital input signal</p> <p>TTL</p>	<ul style="list-style-type: none"> <li>• CMOS-level output</li> <li>• TTL-level input (with standby control)</li> </ul>

(Continued)

(Continued)

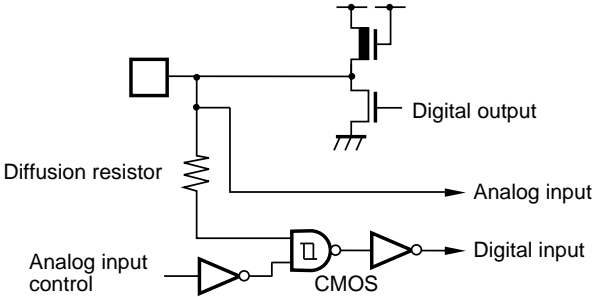
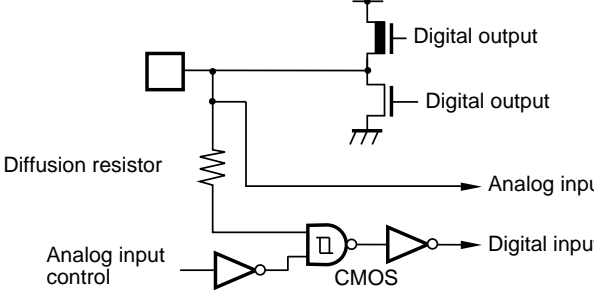
Type	Circuit	Remarks
I	 <p>The circuit diagram for Type I shows a square-wave input connected to a diffusion resistor. The other end of the resistor is connected to the gate of an N-channel MOSFET. The drain of the MOSFET is connected to a pull-up resistor and is labeled 'Digital output'. The source of the MOSFET is connected to ground. The input signal is also connected to an 'Analog input' terminal. A 'Digital input control' signal is connected to the gate of a CMOS inverter, which is also connected to the input signal through a buffer. The output of this inverter is connected to the gate of another CMOS inverter, which is also connected to the input signal through a buffer. The output of this second inverter is labeled 'Digital input control'.</p>	<ul style="list-style-type: none"> <li>• N-ch open-drain CMOS-level output</li> <li>• CMOS-level hysteresis input (analog input) (with analog input control)</li> </ul>
J	 <p>The circuit diagram for Type J is similar to Type I, but it features two N-channel MOSFETs. The first MOSFET has its gate connected to the diffusion resistor and its drain connected to a pull-up resistor, labeled 'Digital output'. The second MOSFET has its gate connected to the diffusion resistor and its drain connected to another pull-up resistor, also labeled 'Digital output'. The source of both MOSFETs is connected to ground. The input signal is connected to an 'Analog input' terminal. A 'Digital input control' signal is connected to the gate of a CMOS inverter, which is also connected to the input signal through a buffer. The output of this inverter is connected to the gate of another CMOS inverter, which is also connected to the input signal through a buffer. The output of this second inverter is labeled 'Digital input control'.</p>	<ul style="list-style-type: none"> <li>• N-ch open-drain CMOS-level output</li> <li>• CMOS-level hysteresis input (analog input) (with analog input control)</li> </ul>

## ■ HANDLING DEVICES

### 1. Preventing Latchup

Latchup may occur on CMOS ICs if voltage higher than  $V_{CC}$  or lower than  $V_{SS}$  is applied to the input or output pins other than medium-and high-voltage pins or if higher than the voltage which shown on “1. Absolute Maximum Ratings” in section “■ Electrical Characteristics” is applied between  $V_{CC}$  and  $V_{SS}$ .

When latchup occurs, power supply current increases rapidly might thermally damage elements. When using, take great care not to exceed the absolute maximum ratings.

In addition, for the same reasons take care to prevent the analog power supply from exceeding the digital power supply.

### 2. Treatment of Unused Pins

Leaving unused input pins open could cause malfunctions. They should be connected to a pull-up or pull-down resistors.

### 3. Precautions when Using an External Clock

When an external clock is used, drive X0 only.

- For example an external clock

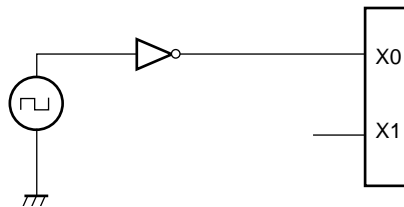

### 4. Power Supply Pins

When there are several  $V_{CC}$  and  $V_{SS}$  pins, those pins that should have the same electric potential are connected within the device when the device is designed in order to prevent misoperation, such as latch-up. However, all of those pins must be connected to the power supply and ground externally in order to reduce unnecessary emissions, prevent misoperation of strobe signals due to an increase in the ground level, and to observe the total output current standards.

In addition, give a due consideration to the connection in that current supply be connected to  $V_{CC}$  and  $V_{SS}$  with the lowest possible impedance.

Finally, it is recommended to connect a capacitor of about  $0.1 \mu\text{F}$  between  $V_{CC}$  and  $V_{SS}$  near this device as a bypass capacitor.

## 5. Crystal Oscillation Circuit

Noise in the vicinity of the X0 and X1 pins will cause this device to operate incorrectly. Design the printed circuit board so that the bypass capacitor connecting X0 and X1 pins and the crystal oscillator (or ceramic oscillator) to ground is located as close to the device as possible.

In addition, because printed circuit board artwork in which the area around the X0 and X1 pins is surrounded by ground provides stable operation, such an arrangement is strongly recommended.

## 6. Sequence for Applying the A/D Converter Power Supply and the Analog Inputs

Always be sure to apply the digital power supply ( $V_{CC}$ ) before applying the A/D converter power supply ( $AV_{CC}$ ,  $AV_{RH}$ , and  $AV_{RL}$ ) and the analog inputs (AN0 to AN7).

In addition, when the power is turned off, turn off the A/D converter power supply and the analog inputs first, and then turn off the digital power supply. (Turning on or off the analog and digital power supplies simultaneously will not cause any problems.)

Whether applying or cutting off the power, be certain that  $AV_{RH}$  does not exceed  $AV_{CC}$ .

## 7. External Reset Input

To reliably reset the controller by inputting an “L” level to the  $\overline{RST}$  pin, ensure that the “L” level is applied for at least five machine cycles.

## 8. $\overline{HST}$ Pin

When turning on the system, be sure to set the  $\overline{HST}$  pin to “H” level. Never set the  $\overline{HST}$  pin to “L” level while the  $\overline{RST}$  pin is in “L” level.

## 9. CLK Pin

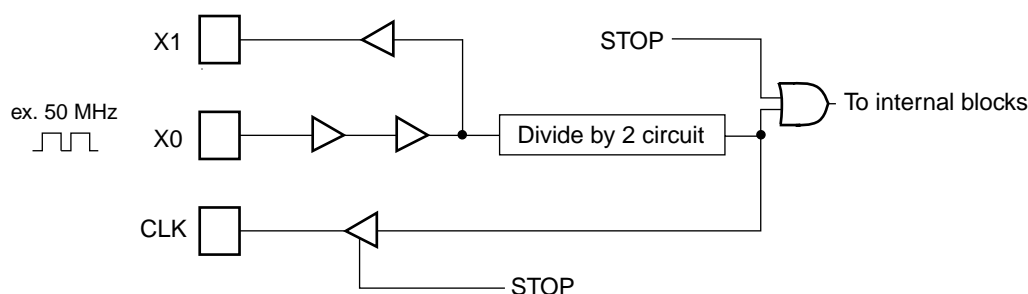

Note: CLK pin cannot use as I/O port.  
Care must be taken that this is different from standard specification for F<sup>2</sup>MC-16F family.

## 10. Specified Interrupt Sequence

When the interrupt stack area is allocated to the external memory, even if the higher priority level interrupt may generate while the former interrupt is waiting in the stack area, the latter higher priority level interrupt routine has to wait until the former interrupt routine is executed. In this case the former interrupt routine is executed in the latter higher priority level.

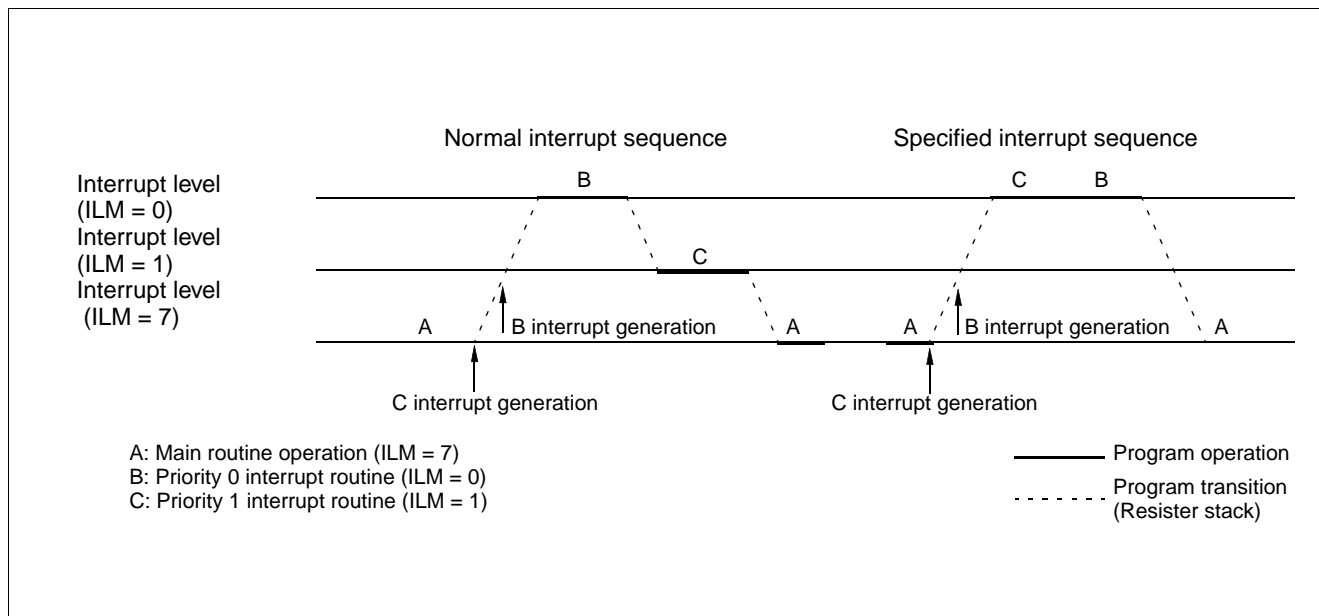



## ■ BLOCK DIAGRAM

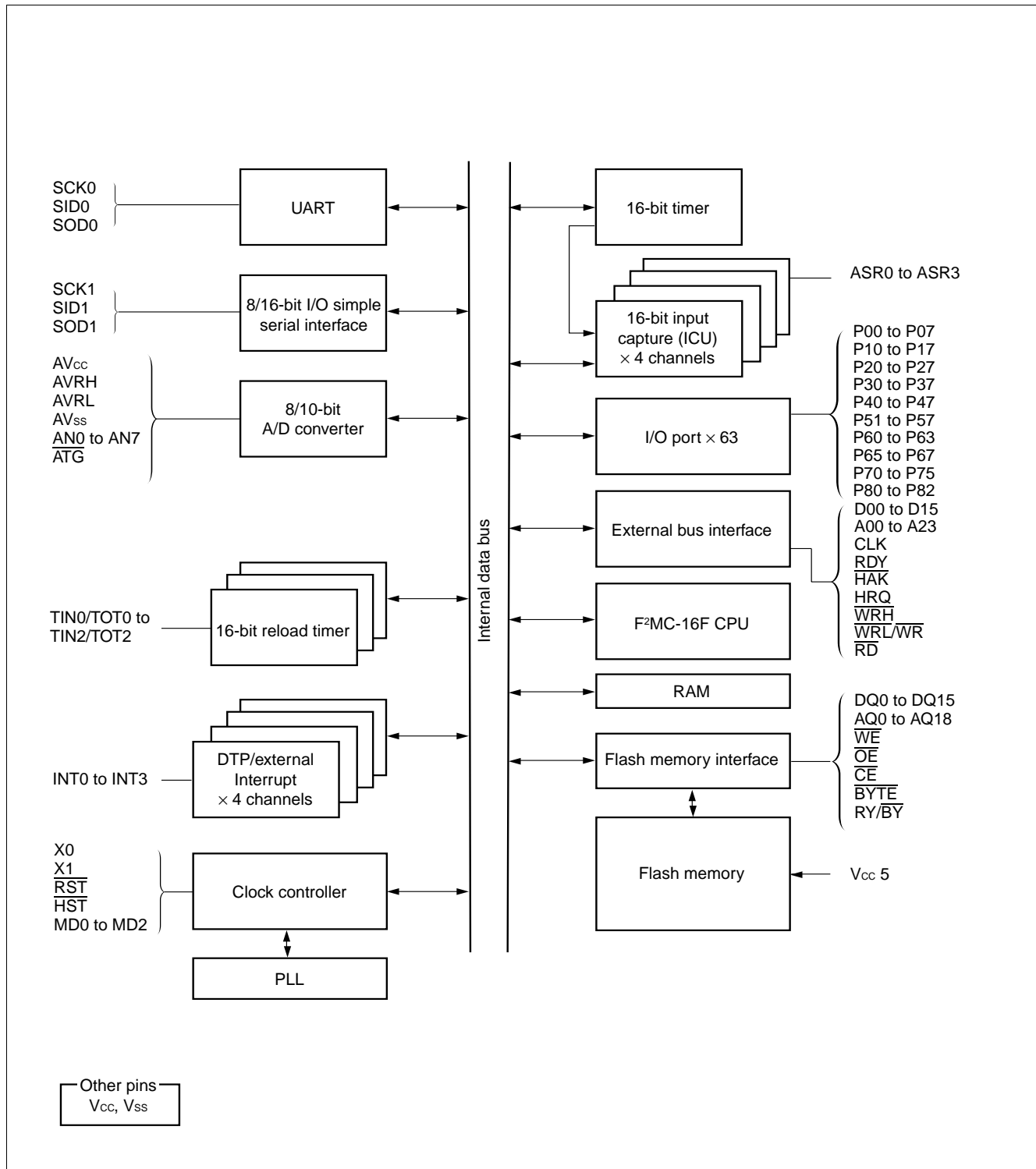

## ■ F<sup>2</sup>MC-16L CPU PROGRAMMING MODEL

### • Dedicated registers

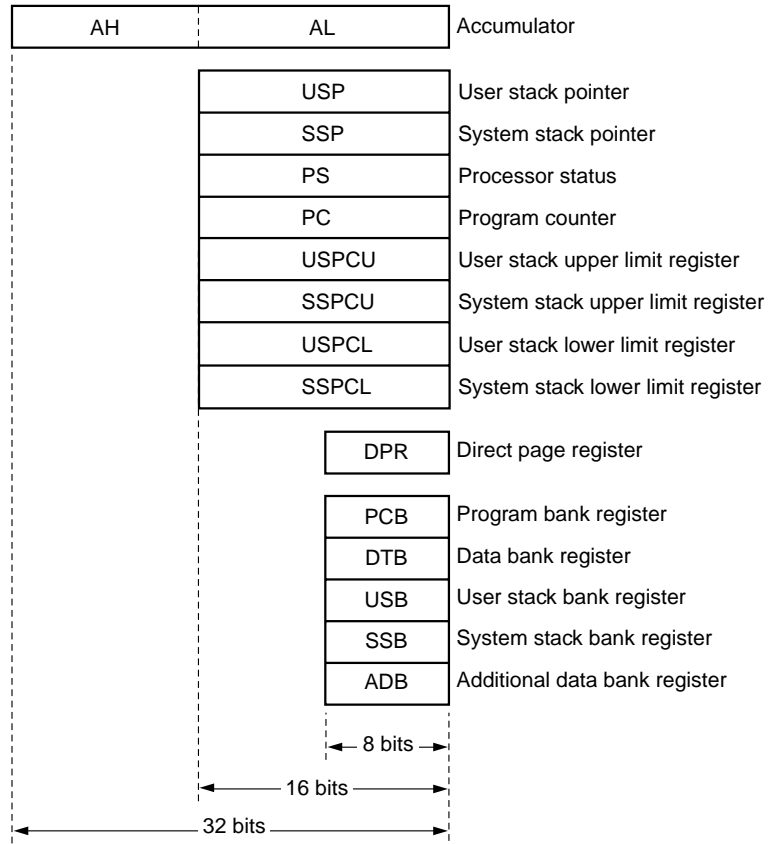

### • General-purpose registers

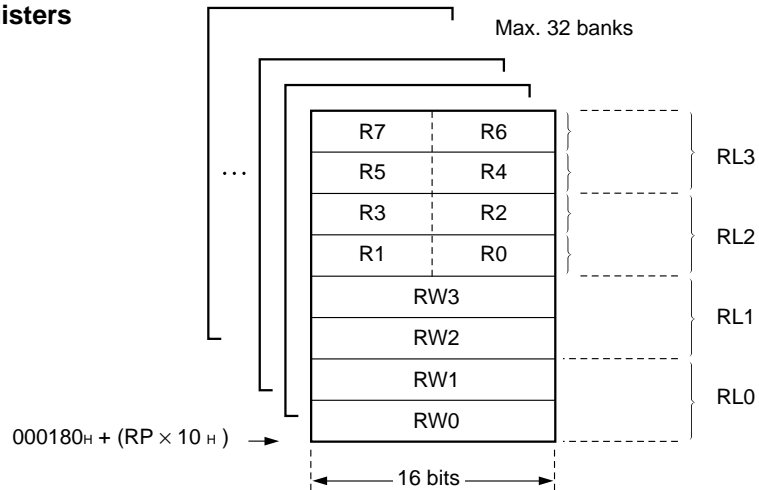

### • Processor status (PS)

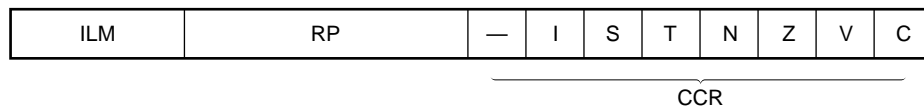

## MEMORY MAP

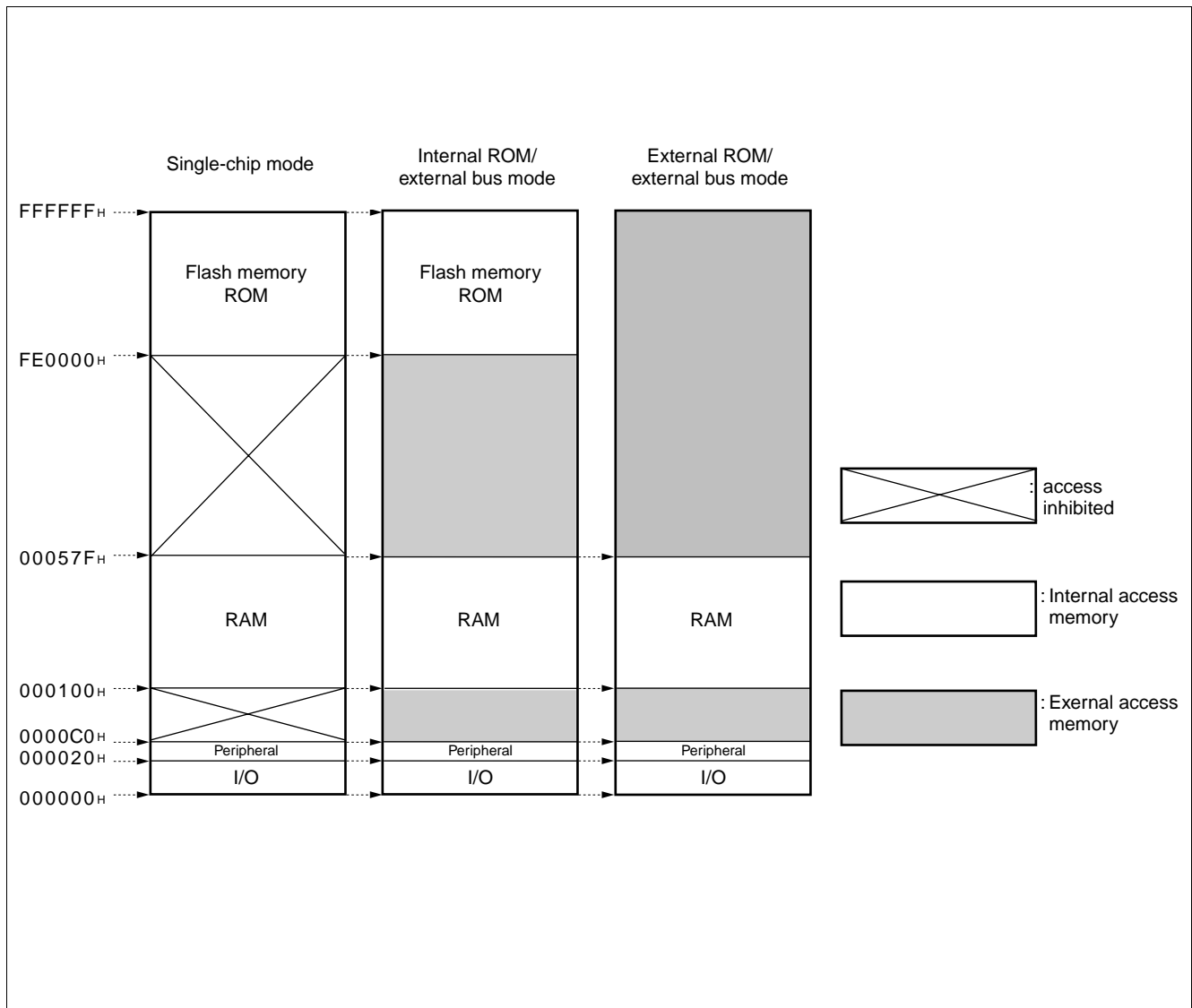

# MB90F244

## ■ I/O MAP

Address	Register name	Register	Read/write	Resource name	Initial value
000000 <sub>H</sub>	PDR0	Port 0 data register	R/W	Port 0	XXXXXXXX <sub>B</sub>
000001 <sub>H</sub>	PDR1	Port 1 data register	R/W	Port 1	XXXXXXXX <sub>B</sub>
000002 <sub>H</sub>	PDR2	Port 2 data register	R/W	Port 2	XXXXXXXX <sub>B</sub>
000003 <sub>H</sub>	PDR3	Port 3 data register	R/W	Port 3	XXXXXXXX <sub>B</sub>
000004 <sub>H</sub>	PDR4	Port 4 data register	R/W	Port 4	XXXXXXXX <sub>B</sub>
000005 <sub>H</sub>	PDR5	Port 5 data register	R/W	Port 5	XXXXXXXX– <sub>B</sub>
000006 <sub>H</sub>	PDR6	Port 6 data register	R/W	Port 6	111–1111 <sub>B</sub>
000007 <sub>H</sub>	PDR7	Port 7 data register	R/W	Port 7	--XXXXXX <sub>B</sub>
000008 <sub>H</sub>	PDR8	Port 8 data register	R/W	Port 8	-----XXX <sub>B</sub>
000009 <sub>H</sub> to 00000F <sub>H</sub>	(Vacancy)				
000010 <sub>H</sub>	DDR0	Port 0 data direction register	R/W	Port 0	00000000 <sub>B</sub>
000011 <sub>H</sub>	DDR1	Port 1 data direction register	R/W	Port 1	00000000 <sub>B</sub>
000012 <sub>H</sub>	DDR2	Port 2 data direction register	R/W	Port 2	00000000 <sub>B</sub>
000013 <sub>H</sub>	DDR3	Port 3 data direction register	R/W	Port 3	00000000 <sub>B</sub>
000014 <sub>H</sub>	DDR4	Port 4 data direction register	R/W	Port 4	00000000 <sub>B</sub>
000015 <sub>H</sub>	DDR5	Port 5 data direction register	R/W	Port 5	0000000– <sub>B</sub>
000016 <sub>H</sub>	ADER	Analog input enable register	R/W	Analog input enabled	11111111 <sub>B</sub>
000017 <sub>H</sub>	DDR7	Port 7 data direction register	R/W	Port 7	--000000 <sub>B</sub>
000018 <sub>H</sub>	DDR8	Port 8 data direction register	R/W	Port 8	-----000 <sub>B</sub>
000019 <sub>H</sub> to 00001F <sub>H</sub>	(Vacancy)				
000020 <sub>H</sub>	SCR1	Serial control status register 1	R/W	8/16-bit I/O simple serial interface ch. 1	10000000 <sub>B</sub>
000021 <sub>H</sub>	SSR1	Serial status register 1	R/W		-----00 <sub>B</sub>
000022 <sub>H</sub>	SDR1L	Serial data register 1 (L)	R/W		XXXXXXXX <sub>B</sub>
000023 <sub>H</sub>	SDR1H	Serial data register 1 (H)	R/W		XXXXXXXX <sub>B</sub>
000024 <sub>H</sub> to 000027 <sub>H</sub>	(Vacancy)				
000028 <sub>H</sub>	UMC0	Mode control register 0	R/W	UART ch. 0	00000100 <sub>B</sub>
000029 <sub>H</sub>	USR0	Status register 0	R/W		00010000 <sub>B</sub>
00002A <sub>H</sub>	UIDR0/ UODR0	Input data register 0/ output data register 0	R/W		XXXXXXXX <sub>B</sub>
00002B <sub>H</sub>	URD0	Rate and data register 0	R/W		00000000 <sub>B</sub>
00002C <sub>H</sub> to 00002E <sub>H</sub>	(Vacancy)				

(Continued)

Address	Register name	Register	Read/write	Resource name	Initial value
00002FH	CKSCR	Clock selection register	R/W	PLL	----1100 <sub>B</sub>
000030H	ENIR	DTP/interrupt enable register	R/W	DTP/external interrupt	----0000 <sub>B</sub>
000031H	EIRR	DTP/interrupt source register	R/W		----0000 <sub>B</sub>
000032H	ELVR	Request level setting register	R/W		00000000 <sub>B</sub>
000033H to 00003FH	(Vacancy)				
000040H	TMCSR0	Timer control status register #0	R/W	16-bit timer #0	00000000 <sub>B</sub>
000041H			R/W		----0000 <sub>B</sub>
000042H	TMR0	16-bit timer register #0	R		XXXXXXXX <sub>B</sub>
000043H			R		XXXXXXXX <sub>B</sub>
000044H	TMRLR0	16-bit reload register #0	W		XXXXXXXX <sub>B</sub>
000045H			W		XXXXXXXX <sub>B</sub>
000046H 000047H	(Vacancy)				
000048H	TMCSR1	Timer control status register #1	R/W	16-bit timer #1	00000000 <sub>B</sub>
000049H			R/W		----0000 <sub>B</sub>
00004AH	TMR1	16-bit timer register #1	R		XXXXXXXX <sub>B</sub>
00004BH			R		XXXXXXXX <sub>B</sub>
00004CH	TMRLR1	16-bit reload register #1	W		XXXXXXXX <sub>B</sub>
00004DH			W		XXXXXXXX <sub>B</sub>
00004EH 00004FH	(Vacancy)				
000050H	TMCSR2	Timer control status register #2	R/W	16-bit timer #2	00000000 <sub>B</sub>
000051H			R/W		----0000 <sub>B</sub>
000052H	TMR2	16-bit timer register #2	R		XXXXXXXX <sub>B</sub>
000053H			R		XXXXXXXX <sub>B</sub>
000054H	TMRLR2	16-bit reload register #2	W		XXXXXXXX <sub>B</sub>
000055H			W		XXXXXXXX <sub>B</sub>
000056H to 00005FH	(Vacancy)				
000060H	ICP0	Input capture register 0	R	16-bit input capture 0 and 1	XXXXXXXX <sub>B</sub>
000061H			R		XXXXXXXX <sub>B</sub>
000062H	ICP1	Input capture register 1	R		XXXXXXXX <sub>B</sub>
000063H			R		XXXXXXXX <sub>B</sub>
000064H	ICS0	Input capture control status register 0 and 1	R/W	00000000 <sub>B</sub>	
000065H	(Vacancy)				

(Continued)

# MB90F244

Address	Register name	Register	Read/write	Resource name	Initial value
000066 <sub>H</sub>	ICP2	Input capture register 2	R	16-bit input capture 2 and 3	XXXXXXXX <sub>B</sub>
000067 <sub>H</sub>					XXXXXXXX <sub>B</sub>
000068 <sub>H</sub>	ICP3	Input capture register 3	R		XXXXXXXX <sub>B</sub>
000069 <sub>H</sub>					XXXXXXXX <sub>B</sub>
00006A <sub>H</sub>	ICS1	Input capture control status register 2 and 3	R/W		00000000 <sub>B</sub>
00006B <sub>H</sub>	(Vacancy)				
00006C <sub>H</sub>	TCDT	Timer data register	R	16-bit freerun timer	00000000 <sub>B</sub>
00006D <sub>H</sub>			R		00000000 <sub>B</sub>
00006E <sub>H</sub>	TCCS	Timer control status register	R/W		
00006F <sub>H</sub>	(Vacancy)				
000070 <sub>H</sub>	ADCS 1	A/D control status register 1	R/W	8/10-bit A/D converter	000-0000 <sub>B</sub>
000071 <sub>H</sub>	ADCS 2	A/D control status register 2	R/W		-000--00 <sub>B</sub>
000072 <sub>H</sub>	ADCT 1	Conversion time setting register 1	R/W		XXXXXXXX <sub>B</sub>
000073 <sub>H</sub>	ADCT 2	Conversion time setting register 2	R/W		XXXXXXXX <sub>B</sub>
000074 <sub>H</sub>	ADTL0	A/D data register 0 (L)	R		XXXXXXXX <sub>B</sub>
000075 <sub>H</sub>	ADTH0	A/D data register 0 (H)	R		-----XX <sub>B</sub>
000076 <sub>H</sub>	ADTL1	A/D data register 1 (L)	R		XXXXXXXX <sub>B</sub>
000077 <sub>H</sub>	ADTH1	A/D data register 1 (H)	R		-----XX <sub>B</sub>
000078 <sub>H</sub>	ADTL2	A/D data register 2 (L)	R		XXXXXXXX <sub>B</sub>
000079 <sub>H</sub>	ADTH2	A/D data register 2 (H)	R		-----XX <sub>B</sub>
00007A <sub>H</sub>	ADTL3	A/D data register 3 (L)	R		XXXXXXXX <sub>B</sub>
00007B <sub>H</sub>	ADTH3	A/D data register 3 (H)	R		-----XX <sub>B</sub>
00007C <sub>H</sub> to 00008F <sub>H</sub>	(Vacancy)				
000090 <sub>H</sub> to 00009E <sub>H</sub>	(System reserved area)*1				
00009F <sub>H</sub>	DIRR	Delayed interrupt source generation/release register	R/W	Delayed interrupt generation module	-----0 <sub>B</sub>
0000A0 <sub>H</sub>	STBYC	Standby control register	R/W	Low-power consumption mode	0001XXXX <sub>B</sub>
0000A3 <sub>H</sub>	MACR	Middle address control register	W	External pin	*2
0000A4 <sub>H</sub>	HACR	High address control register	W		*2
0000A5 <sub>H</sub>	EPCR	External pin control register	W		*2

(Continued)

(Continued)

Address	Register name	Register	Read/write	Resource name	Initial value
0000A8 <sub>H</sub>	WTC	Watchdog timer control register	R/W	Watchdog timer	XXXXXXXX <sub>B</sub>
0000A9 <sub>H</sub>	TBTC	Timebase timer control register	R/W	Timebase timer	0XX00000 <sub>B</sub>
0000AE <sub>H</sub>	FMCS	Control status register	R/W	Flash memory	000X0--0 <sub>B</sub>
0000B0 <sub>H</sub>	ICR00	Interrupt control register 00	R/W <sup>*3</sup>	Interrupt controller	00000111 <sub>B</sub>
0000B1 <sub>H</sub>	ICR01	Interrupt control register 01	R/W <sup>*3</sup>		00000111 <sub>B</sub>
0000B2 <sub>H</sub>	ICR02	Interrupt control register 02	R/W <sup>*3</sup>		00000111 <sub>B</sub>
0000B3 <sub>H</sub>	ICR03	Interrupt control register 03	R/W <sup>*3</sup>		00000111 <sub>B</sub>
0000B4 <sub>H</sub>	ICR04	Interrupt control register 04	R/W <sup>*3</sup>		00000111 <sub>B</sub>
0000B5 <sub>H</sub>	ICR05	Interrupt control register 05	R/W <sup>*3</sup>		00000111 <sub>B</sub>
0000B6 <sub>H</sub>	ICR06	Interrupt control register 06	R/W <sup>*3</sup>		00000111 <sub>B</sub>
0000B7 <sub>H</sub>	ICR07	Interrupt control register 07	R/W <sup>*3</sup>		00000111 <sub>B</sub>
0000B8 <sub>H</sub>	ICR08	Interrupt control register 08	R/W <sup>*3</sup>		00000111 <sub>B</sub>
0000B9 <sub>H</sub>	ICR09	Interrupt control register 09	R/W <sup>*3</sup>		00000111 <sub>B</sub>
0000BA <sub>H</sub>	ICR10	Interrupt control register 10	R/W <sup>*3</sup>		00000111 <sub>B</sub>
0000BB <sub>H</sub>	ICR11	Interrupt control register 11	R/W <sup>*3</sup>		00000111 <sub>B</sub>
0000BC <sub>H</sub>	ICR12	Interrupt control register 12	R/W <sup>*3</sup>		00000111 <sub>B</sub>
0000BD <sub>H</sub>	ICR13	Interrupt control register 13	R/W <sup>*3</sup>		00000111 <sub>B</sub>
0000BE <sub>H</sub>	ICR14	Interrupt control register 14	R/W <sup>*3</sup>		00000111 <sub>B</sub>
0000BF <sub>H</sub>	ICR15	Interrupt control register 15	R/W <sup>*3</sup>		00000111 <sub>B</sub>
0000C0 <sub>H</sub> to 0000FF <sub>H</sub>	(External area) <sup>*3</sup>				

**Explanation of read/write**

R/W : Readable and writable

R : Read only

W : Write only

**Explanation of initial values**

0 : The initial value of this bit is "0".

1 : The initial value of this bit is "1".

X : The initial value of this bit is undefined.

– : This bit is unused. No initial value is defined.

\*1: Access prohibited.

\*2: The initial values are changed depending on a bus mode.

\*3: The only area available for the external access below address 0000FF<sub>H</sub> is this area. Addresses not explained in the table are "(reserved area)"; accesses to these areas are handled accesses to internal areas. No access signal is generated for the external bus.

Note: Do not use any "(vacancy)".

# MB90F244

## ■ ELECTRICAL CHARACTERISTICS

### 1. Absolute Maximum Ratings

( $AV_{SS} = V_{SS} = 0.0\text{ V}$ )

Parameter	Symbol	Value		Unit	Remarks
		Min.	Max.		
Power supply voltage	$V_{CC}$	$V_{SS} - 0.3$	$V_{SS} + 4.0$	V	
	$V_{CC5}$	$V_{SS} - 0.3$	$V_{SS} + 7.0$	V	*1
	$AV_{CC}$	$V_{SS} - 0.3$	$V_{SS} + 4.0$	V	*2
	$AV_{RH}$	$V_{SS} - 0.3$	$V_{SS} + 4.0$	V	*2
	$AV_{RL}$	$V_{SS} - 0.3$	$V_{SS} + 4.0$	V	*2
Input voltage	$V_{I1}$	$V_{SS} - 0.3$	$V_{CC} + 0.3$	V	*3
	$V_{I2}$	$V_{SS} - 0.3$	$V_{CC5} + 0.3$	V	*4
Output voltage	$V_O$	$V_{SS} - 0.3$	$V_{CC} + 0.3$	V	*3
"L" level maximum output current	$I_{OL}$	—	10	mA	
"L" level average output current	$I_{OLAV}$	—	3	mA	
"L" level total maximum output current	$\Sigma I_{OL}$	—	60	mA	
"L" level total average output current	$\Sigma I_{OLAV}$	—	30	mA	
"H" level maximum output current	$I_{OH}$	—	-10	mA	
"H" level average output current	$I_{OHAV}$	—	-3	mA	
"H" level total maximum output current	$\Sigma I_{OH}$	—	-60	mA	
"H" level total average output current	$\Sigma I_{OHAV}$	—	-30	mA	
Power consumption	$P_D$	—	350	mW	
Operating temperature	$T_A$	0	+70	°C	
Storage temperature	$T_{stg}$	-55	+125	°C	

\*1:  $V_{CC5}$  must always exceed  $V_{CC}$ .

\*2:  $AV_{CC}$ ,  $AV_{RH}$  and  $AV_{RL}$  must not exceed  $V_{CC}$ . Also  $AV_{RL}$  must not exceed  $AV_{RH}$ .

\*3:  $V_{I1}$  and  $V_O$  must not exceed  $V_{CC} + 0.3\text{ V}$ .

\*4:  $V_{I2}$  must not exceed  $V_{CC5} + 0.3\text{ V}$ .

WARNING: Semiconductor devices can be permanently damaged by application of stress (voltage, current, temperature, etc.) in excess of absolute maximum ratings. Do not exceed these ratings.



## 2. Recommended Operating Conditions

( $A_{V_{SS}} = V_{SS} = 0.0 \text{ V}$ )

Parameter	Symbol	Value		Unit	Remarks
		Min.	Max.		
Power supply voltage	$V_{CC}$	3.0	3.6	V	Normal operation
	$V_{CC}$	3.0	3.6	V	Maintaining the stop status
	$V_{CC5}$	4.5	5.5	V	
Operating temperature	$T_A$	0	+70	°C	

**WARNING:** The recommended operating conditions are required in order to ensure the normal operation of the semiconductor device. All of the device's electrical characteristics are warranted when the device is operated within these ranges.

Always use semiconductor devices within their recommended operating condition ranges. Operation outside these ranges may adversely affect reliability and could result in device failure.

No warranty is made with respect to uses, operating conditions, or combinations not represented on the data sheet. Users considering application outside the listed conditions are advised to contact their FUJITSU representatives beforehand.

# MB90F244

## 3. DC Characteristics

( $V_{CC5} = 5.0\text{ V} \pm 0.5\text{ V}$ ,  $V_{CC} = 3.3\text{ V} \pm 0.3\text{ V}$ ,  $A_{VSS} = V_{SS} = 0.0\text{ V}$ ,  $T_A = 0^\circ\text{C}$  to  $+70^\circ\text{C}$ )

Parameter	Symbol	Pin name	Condition	Value		Unit	Remarks
				Min.	Max.		
"H" level input voltage	$V_{IH2}$	—	—	$0.7 V_{CC}$	$V_{CC5} + 0.3$	V	TTL input
	$V_{IH1S}$	P60 to P63, P65 to P67, P70		$0.8 V_{CC}$	$V_{CC} + 0.3$	V	CMOS hysteresis input
	$V_{IH2S}$	—		$0.8 V_{CC}$	$V_{CC5} + 0.3$	V	CMOS hysteresis input
	$V_{IH2S5}$	$\overline{RST}$ , $\overline{HST}$		$0.8 V_{CC5}$	$V_{CC5} + 0.3$	V	CMOS hysteresis input
	$V_{IHM}$	MD0 to MD2		$0.7 V_{CC5}$	$V_{CC5} + 0.3$	V	CMOS input
"L" level input voltage	$V_{IL2}$	—	—	$V_{SS} - 0.3$	$0.2 V_{CC}$	V	TTL input
	$V_{IL1S}$	P60 to P63, P65 to P67, P70		$V_{SS} - 0.3$	$0.2 V_{CC}$	V	CMOS hysteresis input
	$V_{IL2S}$	—		$V_{SS} - 0.3$	$0.2 V_{CC}$	V	CMOS hysteresis input
	$V_{IL2S5}$	$\overline{RST}$ , $\overline{HST}$		$V_{SS} - 0.3$	$0.2 V_{CC5}$	V	CMOS hysteresis input
	$V_{ILM}$	MD0 to MD2		$V_{SS} - 0.3$	$0.2 V_{CC5}$	V	CMOS input
"H" level output voltage	$V_{OH}$	All ports except port 6	$V_{CC} = 3.0\text{ V}$ $I_{OH} = -1.6\text{ mA}$	$V_{CC} - 0.3$	—	V	
"L" level output voltage	$V_{OL}$	All ports	$V_{CC} = 3.0\text{ V}$ $I_{OL} = 2.0\text{ mA}$	—	0.4	V	
"H" level input current	$I_{IH1}$	MD0 to MD2	$V_{CC} = 3.6\text{ V}$ $V_{CC5} = 5.5\text{ V}$ $V_{IH} = 0.7 V_{CC5}$	—	-10	$\mu\text{A}$	CMOS input
	$I_{IH2}$	—	$V_{CC} = 3.6\text{ V}$ $V_{CC5} = 5.5\text{ V}$ $V_{IH} = 2.2\text{ V}$	—	-10	$\mu\text{A}$	TTL input
	$I_{IH3}$	Except port 6, $\overline{RST}$ , $\overline{HST}$	$V_{CC} = 3.6\text{ V}$ $V_{CC5} = 5.5\text{ V}$ $V_{IH} = 0.8 V_{CC}$	—	-10	$\mu\text{A}$	CMOS hysteresis input
	$I_{IH4}$	P60 to P63, P65 to P67	$V_{CC} = 3.6\text{ V}$ $V_{CC5} = 5.5\text{ V}$ $V_{IH} = 0.7 V_{CC}$	—	-10	$\mu\text{A}$	CMOS hysteresis input Only port 6
"L" level input current	$I_{IL1}$	MD0 to MD2	$V_{CC} = 3.6\text{ V}$ $V_{CC5} = 5.5\text{ V}$ $V_{IL} = 0.3 V_{CC5}$	—	10	$\mu\text{A}$	CMOS input
	$I_{IL2}$	—	$V_{CC} = 3.6\text{ V}$ $V_{CC5} = 5.5\text{ V}$ $V_{IL} = 0.8\text{ V}$	—	10	$\mu\text{A}$	TTL input
	$I_{IL3}$	Except port 6, $\overline{RST}$ , $\overline{HST}$	$V_{CC} = 3.6\text{ V}$ $V_{CC5} = 5.5\text{ V}$ $V_{IL} = 0.2 V_{CC}$	—	10	$\mu\text{A}$	CMOS hysteresis input
	$I_{IL4}$	P60 to P63, P65 to P67	$V_{CC} = 3.6\text{ V}$ $V_{CC5} = 5.5\text{ V}$ $V_{IL} = 0.3 V_{CC}$	—	10	$\mu\text{A}$	CMOS hysteresis input Only port 6

(Continued)

(Continued)

( $V_{CC5} = 5.0\text{ V} \pm 0.5\text{ V}$ ,  $V_{CC} = 3.3\text{ V} \pm 0.3\text{ V}$ ,  $A_{VSS} = V_{SS} = 0.0\text{ V}$ ,  $T_A = 0^\circ\text{C}$  to  $+70^\circ\text{C}$ )

Parameter	Symbol	Pin name	Condition	Value			Unit	Remarks	
				Min.	Typ.	Max.			
Power supply current*1	I <sub>CC1</sub>	V <sub>CC</sub>	CPU normal mode at 25 MHz	V <sub>CC</sub> = 3.15 V to 3.6 V	—	—	50	mA	Flash memory read state
	I <sub>CC1</sub>	V <sub>CC</sub>		V <sub>CC</sub> = 3.3 V ±0.15 V	—	—	45	mA	Flash memory read state
	I <sub>CC51</sub>	V <sub>CC5</sub>		—	—	—	33	mA	Flash memory read state
	I <sub>CC2</sub>	V <sub>CC</sub>	CPU normal mode at 25 MHz	V <sub>CC</sub> = 3.15 V to 3.6 V	—	—	50	mA	Flash memory program/erase state
	I <sub>CC2</sub>	V <sub>CC</sub>		V <sub>CC</sub> = 3.3 V ±0.15 V	—	—	45	mA	Flash memory program/erase state
	I <sub>CC52</sub>	V <sub>CC5</sub>		—	—	—	53	mA	Flash memory program/erase state
	I <sub>CCS</sub>	V <sub>CC</sub>	CPU sleep mode At 25 MHz	—	—	—	20	mA	
	I <sub>CC5S</sub>	V <sub>CC5</sub>		—	—	—	5	mA	
	I <sub>CCH</sub>	V <sub>CC</sub>	CPU stop mode T <sub>A</sub> = +25°C	—	—	—	100	μA	
I <sub>CC5H</sub>	V <sub>CC5</sub>	—		—	—	100	μA		
Input capacitance	C <sub>IN</sub>	Except V <sub>CC</sub> , V <sub>CC5</sub> , V <sub>SS</sub>	—	—	10	—	pF		
Pull-up resistor	R <sub>PULL</sub>	$\overline{\text{RST}}$	V <sub>CC</sub> = 3.3 V V <sub>CC5</sub> = 5.0 V	22	—	220	kΩ		
Open-drain output leakage voltage	I <sub>LEAK</sub>	Port 6	—	—	—	10	μA		
Low V <sub>CC5</sub> lock voltage*2	V <sub>LKO</sub>	—	—	TBD	—	3.6	V		

\*1: Because the current values are tentative values, they are subject to change without notice due to our efforts to improve the characteristics of these devices.

\*2: To prevent improper commands from being activated during rise and fall of V<sub>CC5</sub>, the internal V<sub>CC5</sub> detection circuit of the flash memory allows only read accesses and ignores write accesses while V<sub>CC5</sub> is lower than V<sub>LKO</sub>.

## 4. Flash Memory Programming/Erasing Characteristics

( $V_{CC5} = 5.0\text{ V} \pm 0.5\text{ V}$ ,  $V_{CC} = 3.3\text{ V} \pm 0.3\text{ V}$ ,  $A_{V_{SS}} = V_{SS} = 0.0\text{ V}$ ,  $T_A = 0^\circ\text{C}$  to  $+70^\circ\text{C}$ )

Parameter	Condition	Value			Unit	Remarks
		Min.	Typ.	Max.		
Sector erasing time	$T_A = +25^\circ\text{C}$ , $V_{CC} = 3.3\text{ V}$ , $V_{CC5} = 5.0\text{ V}$	—	1.5	13.5	sec	Except for the write time before internal erase operation
Chip erasing time		—	—	27.0	sec	Except for the write time before internal erase operation
Byte programming time		—	16	—	$\mu\text{s}$	Except for the over head time of the system
Chip programming time		—	2.1	—	sec	Except for the over head time of the system
Erase/program cycle	—	100	—	—	cycles	

\* : The internal automatic algorithm continues operations for up to 48 ms, for each 1-byte writing operation.

## 5. AC Characteristics

### (1) Clock Timing

( $V_{CC} = 3.3\text{ V} \pm 0.3\text{ V}$ ,  $V_{CC5} = 5.0\text{ V} \pm 0.5\text{ V}$ ,  $A_{VSS} = V_{SS} = 0.0\text{ V}$ ,  $T_A = 0^\circ\text{C}$  to  $+70^\circ\text{C}$ )

Parameter	Symbol	Pin name	Condition	Value		Unit	Remarks
				Min.	Max.		
Clock frequency	$F_C$	X0, X1	$V_{CC} = 3.15\text{ V}$ to $3.6\text{ V}$	—	50	MHz	
	$F_C$	X0, X1	$V_{CC} = 3.3\text{ V} \pm 0.3\text{ V}$	—	40	MHz	
Clock cycle time	$t_c$	X0, X1	—	$1/F_C$	—	ns	
Input clock pulse width	$P_{WH}$ , $P_{WL}$	X0		10	—	ns	
	Input clock rising/falling time	$t_{CR}$ , $t_{CF}$		—	8	ns	

#### • Clock timing

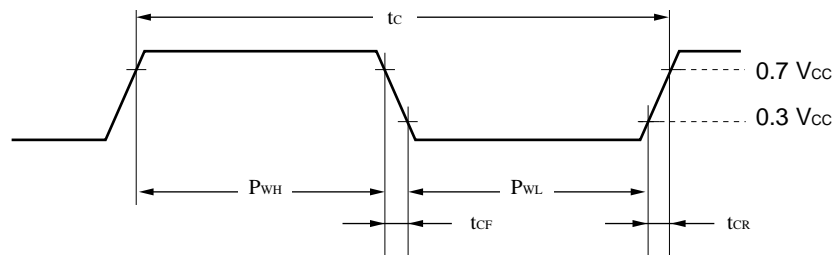

#### • Relationship between clock frequency and power supply voltage

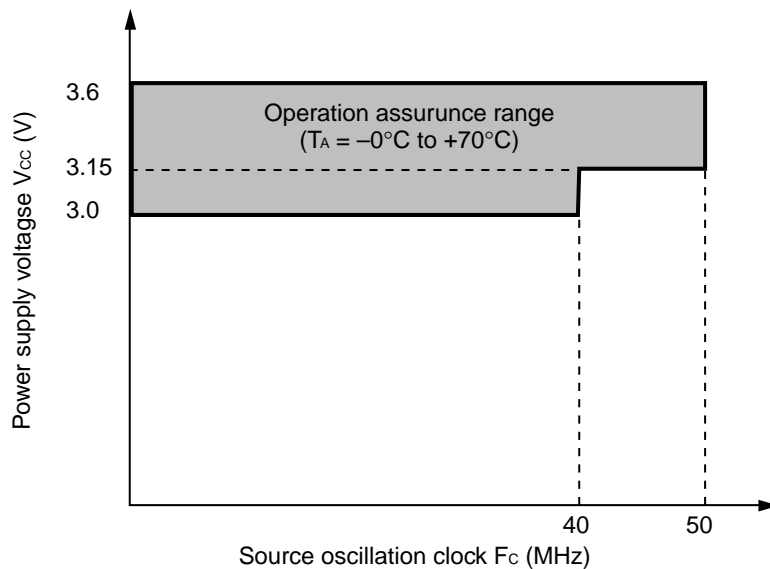

# MB90F244

## (2) Clock Output Timing

( $V_{CC} = 3.3\text{ V} \pm 0.3\text{ V}$ ,  $V_{CC5} = 5.0\text{ V} \pm 0.5\text{ V}$ ,  $AV_{SS} = V_{SS} = 0.0\text{ V}$ ,  $T_A = 0^\circ\text{C}$  to  $+70^\circ\text{C}$ )

Parameter	Symbol	Pin name	Condition	Value		Unit	Remarks
				Min.	Max.		
Cycle time	$t_{CYC}$	CLK	—	$2 t_c^*$	—	ns	
CLK $\uparrow \rightarrow$ CLK $\downarrow$	$t_{CHCL}$	CLK		$1 t_{CYC}/2 - 15$	$1 t_{CYC}/2 + 15$	ns	

\* : For information on  $t_c$  (clock cycle time), see "(1) Clock Timing."

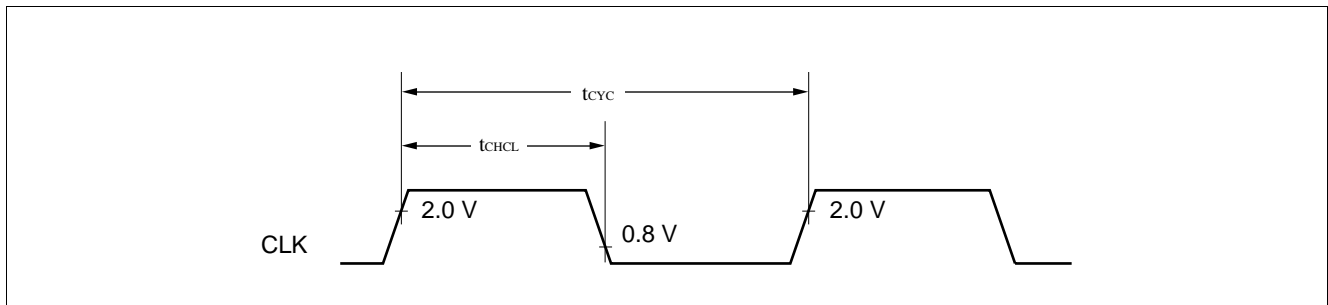

## (3) Reset and Hardware Standby Input

( $V_{CC} = 3.3\text{ V} \pm 0.3\text{ V}$ ,  $V_{CC5} = 5.0\text{ V} \pm 0.5\text{ V}$ ,  $AV_{SS} = V_{SS} = 0.0\text{ V}$ ,  $T_A = 0^\circ\text{C}$  to  $+70^\circ\text{C}$ )

Parameter	Symbol	Pin name	Condition	Value		Unit	Remarks
				Min.	Max.		
Reset input time	$t_{RSTL}$	$\overline{RST}$	—	$5 t_{CYC}^*$	—	ns	
Hardware standby input time	$t_{HSTL}$	$\overline{HST}$		$5 t_{CYC}^*$	—	ns	

\* : For information on  $t_{CYC}$  (cycle time), see "(2) Clock Output Timing."

Note: When hardware standby input is given, the machine cycle is simultaneously selected to be divide-by-32.

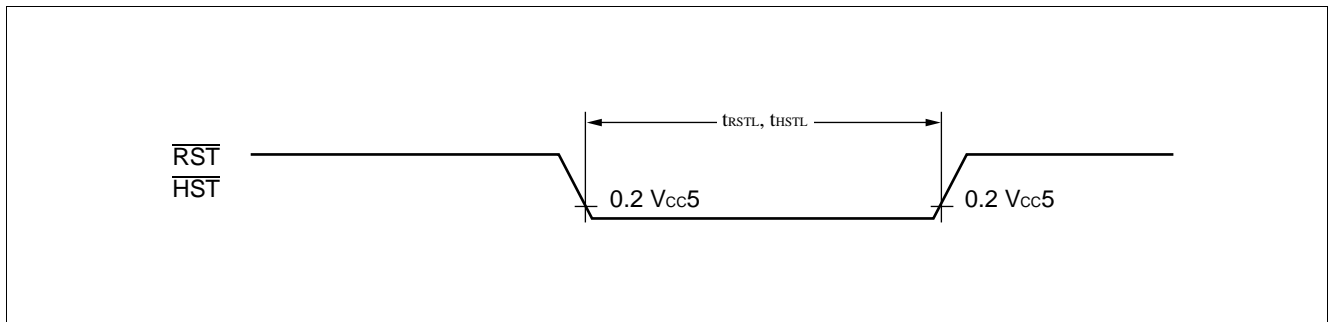

## (4) Power-on Reset

( $V_{SS} = V_{SS} = 0.0\text{ V}$ ,  $T_A = 0^\circ\text{C}$  to  $+70^\circ\text{C}$ )

Parameter	Symbol	Pin name	Condition	Value		Unit	Remarks
				Min.	Max.		
Power supply rising time	$t_R$	$V_{CC}, V_{CC5}$	—	—	30	ms	*
Power supply cut-off time	$t_{OFF}$	$V_{CC}, V_{CC5}$	—	1	—	ms	

\* : Before the power supply rising,  $V_{CC}$  must be lower than 0.2 V.

Note: The above standards are the values needed in order to activate a power-on reset.

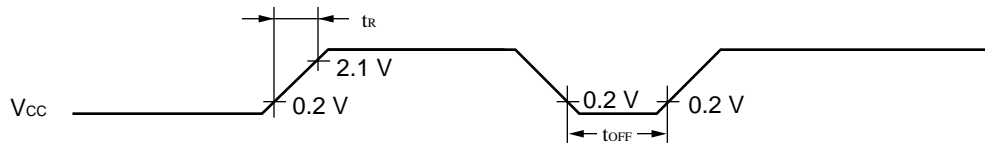

If power supply voltage needs to be changed in the course of operation, a smooth voltage rise is recommended by suppressing the voltage variation as shown below.

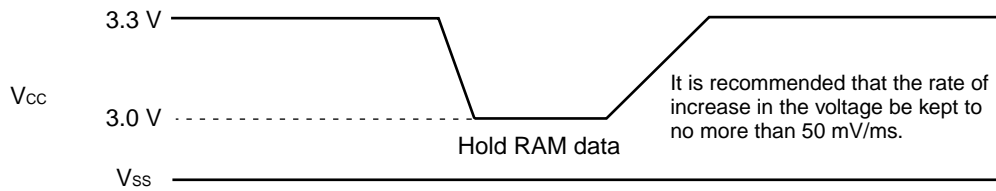

# MB90F244

## (5) Bus Read Timing

( $V_{CC} = 3.3\text{ V} \pm 0.3\text{ V}$ ,  $V_{CC5} = 5.0\text{ V} \pm 0.5\text{ V}$ ,  $A_{VSS} = V_{SS} = 0.0\text{ V}$ ,  $T_A = 0^\circ\text{C}$  to  $+70^\circ\text{C}$ )

Parameter	Symbol	Pin name	Condition	Value		Unit	Remarks
				Min.	Max.		
Address cycle time	$t_{ACYC}$	AN23 to AN00	—	$2 t_{CYC}^* - 10$	—	ns	
Valid address $\rightarrow \overline{RD} \downarrow$ time	$t_{AVRL}$	AN23 to AN00		$1 t_{CYC}^*/2 - 13$	—	ns	
$\overline{RD}$ pulse width	$t_{RLRH}$	$\overline{RD}$		$1 t_{CYC}^* - 20$	—	ns	
$\overline{RD} \downarrow \rightarrow$ data read time	$t_{RLDV}$	D15 to D00		—	$1 t_{CYC}^* - 30$	ns	
Valid address $\rightarrow$ data read time	$t_{AVDV}$	D15 to D00		—	$3 t_{CYC}^*/2 - 30$	ns	
$\overline{RD} \uparrow \rightarrow$ data hold time	$t_{RHDX}$	D15 to D00		0	—	ns	
$\overline{RD} \uparrow \rightarrow$ address valid time	$t_{RHAX}$	AN23 to AN00		$1 t_{CYC}^*/2 - 20$	—	ns	
Valid address $\rightarrow$ CLK $\uparrow$ time	$t_{AVCH}$	AN23 to AN00, CLK		$1 t_{CYC}^*/2 - 20$	—	ns	
$\overline{RD} \downarrow \rightarrow$ CLK $\downarrow$ time	$t_{RLCL}$	$\overline{RD}$ , CLK		$1 t_{CYC}^*/2 - 20$	—	ns	

\* : For information on  $t_{CYC}$  (cycle time), see “(2) Clock Output Timing.”

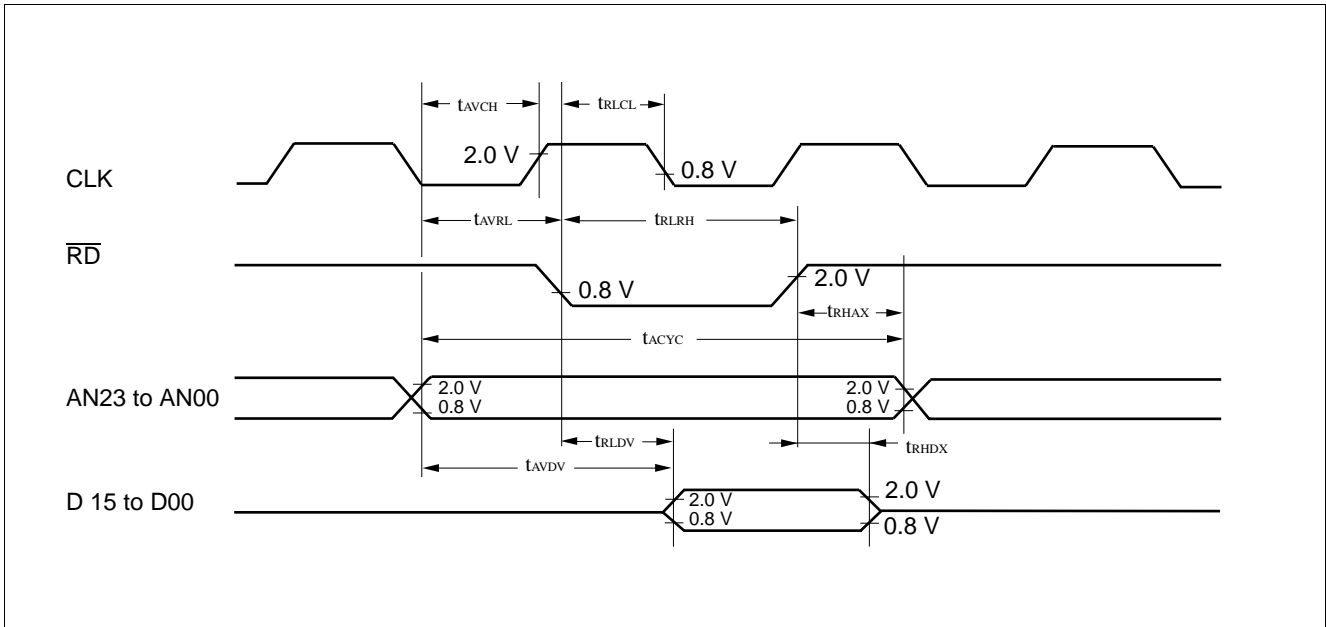



## (6) Bus Write Timing

( $V_{CC} = 3.3\text{ V} \pm 0.3\text{ V}$ ,  $V_{CC5} = 5.0\text{ V} \pm 0.5\text{ V}$ ,  $A_{VSS} = V_{SS} = 0.0\text{ V}$ ,  $T_A = 0^\circ\text{C}$  to  $+70^\circ\text{C}$ )

Parameter	Symbol	Pin name	Condition	Value		Unit	Remarks
				Min.	Max.		
Valid address $\rightarrow \overline{\text{WR}} \downarrow$ time	$t_{\text{AVWL}}$	AN23 to AN00	—	$1\ t_{\text{CYC}}^* / 2 - 13$	—	ns	
$\overline{\text{WR}}$ pulse width	$t_{\text{WLWH}}$	$\overline{\text{WRL}}$ , $\overline{\text{WRH}}$		$1\ t_{\text{CYC}}^* - 20$	—	ns	
Write data $\rightarrow \overline{\text{WR}} \uparrow$ time	$t_{\text{DVWH}}$	D15 to D00		$1\ t_{\text{CYC}}^* - 33$	—	ns	
$\overline{\text{WR}} \uparrow \rightarrow$ Data hold time	$t_{\text{WHDX}}$	D15 to D00		$1\ t_{\text{CYC}}^* / 2 - 15$	—	ns	
$\overline{\text{WR}} \uparrow \rightarrow$ Address valid time	$t_{\text{WHAX}}$	AN23 to AN00		$1\ t_{\text{CYC}}^* / 2 - 15$	—	ns	
$\overline{\text{WR}} \uparrow \rightarrow$ CLK $\downarrow$ time	$t_{\text{WLCL}}$	$\overline{\text{WRL}}$ , $\overline{\text{WRH}}$ , CLK		$1\ t_{\text{CYC}}^* / 2 - 20$	—	ns	

\* : For information on  $t_{\text{CYC}}$  (cycle time), see "(2) Clock Output Timing."

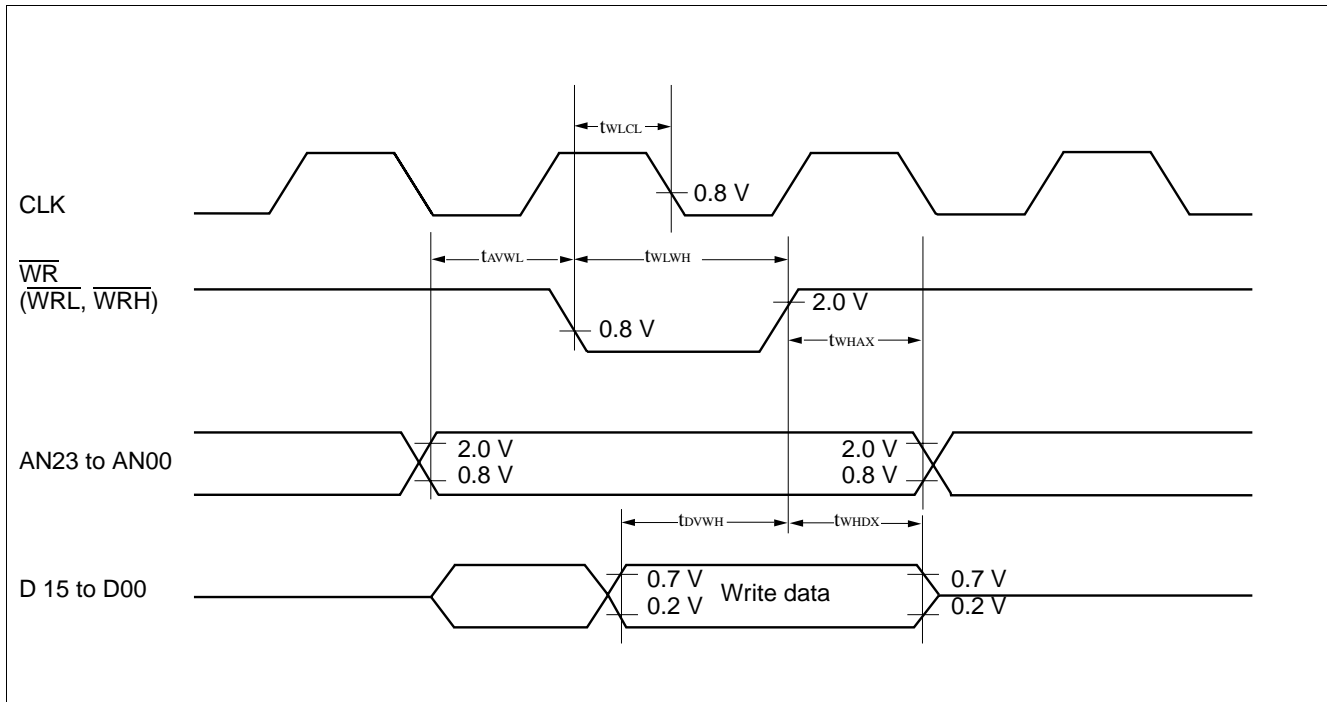

# MB90F244

## (7) Ready Input Timing

( $V_{CC} = 3.3\text{ V} \pm 0.3\text{ V}$ ,  $V_{CC5} = 5.0\text{ V} \pm 0.5\text{ V}$ ,  $AV_{SS} = V_{SS} = 0.0\text{ V}$ ,  $T_A = 0^\circ\text{C}$  to  $+70^\circ\text{C}$ )

Parameter	Symbol	Pin name	Condition	Value		Unit	Remarks
				Min.	Max.		
RDY setup time	$t_{RYHS}$	RDY	Source oscillation 50 MHz	15	38	ns	
RDY hold time	$t_{RYHH}$	RDY		0	38	ns	

Note: If the RDY setup time is insufficient, use the auto ready function.

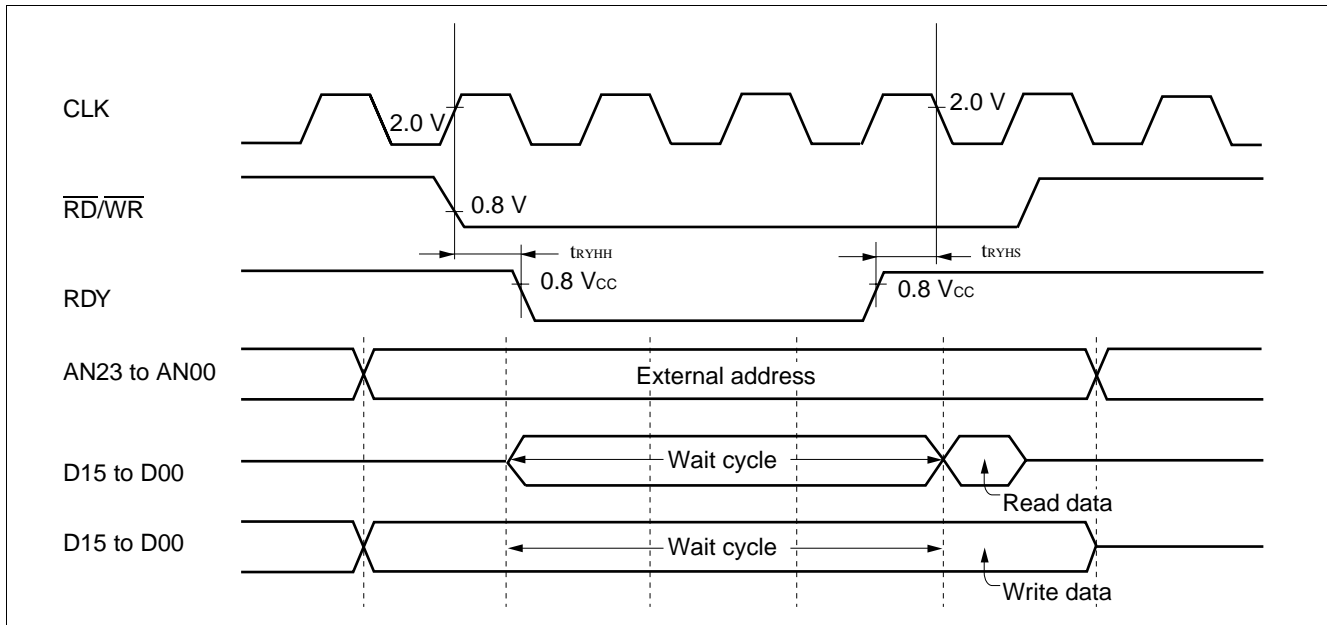

## (8) Hold Timing

( $V_{CC} = 3.0\text{ V} \pm 0.3\text{ V}$ ,  $V_{CC5} = 5.0\text{ V} \pm 0.5\text{ V}$ ,  $AV_{SS} = V_{SS} = 0.0\text{ V}$ ,  $T_A = 0^\circ\text{C}$  to  $+70^\circ\text{C}$ )

Parameter	Symbol	Pin name	Condition	Value		Unit	Remarks
				Min.	Max.		
Pin floating $\rightarrow \overline{\text{HAK}} \downarrow$ time	$t_{XHAL}$	$\overline{\text{HAK}}$	—	30	$1\ t_{CYC}^*$	ns	
$\overline{\text{HAK}}$ time $\uparrow \rightarrow$ Pin valid time	$t_{HAHV}$	$\overline{\text{HAK}}$		$1\ t_{CYC}^*$	$2\ t_{CYC}^*$	ns	

\* : For information on  $t_{CYC}$  (cycle time), see "(2) Clock Output Timing."

Note: At least one cycle is required from the time when HRQ is fetched until  $\overline{\text{HAK}}$  changes.

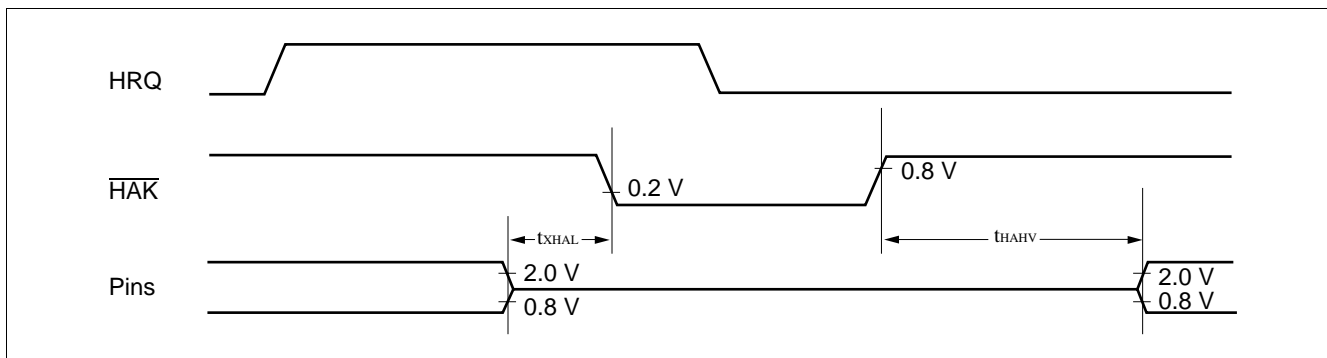

## (9) UART Timing

( $V_{CC} = 3.3\text{ V} \pm 0.3\text{ V}$ ,  $V_{CC5} = 5.0\text{ V} \pm 0.5\text{ V}$ ,  $A_{VSS} = V_{SS} = 0.0\text{ V}$ ,  $T_A = 0^\circ\text{C}$  to  $+70^\circ\text{C}$ )

Parameter	Symbol	Pin name	Condition	Value		Unit	Remarks
				Min.	Max.		
Serial clock cycle time	t <sub>SCYC</sub>	—	For internal shift clock mode output pin, C <sub>L</sub> = 80 pF	8 t <sub>CYC</sub> *	—	ns	
SCK ↓ → SOD delay time	t <sub>SLOV</sub>	—		-80	80	ns	
Valid SID → SCK ↑	t <sub>IVSH</sub>	—		100	—	ns	
SCK ↑ → Valid SID hold time	t <sub>SHIX</sub>	—		60	—	ns	
Serial clock "H" pulse width	t <sub>SHSL</sub>	—	For external shift clock mode output pin, C <sub>L</sub> = 80 pF	4 t <sub>CYC</sub> *	—	ns	
Serial clock "L" pulse width	t <sub>SLSH</sub>	—		4 t <sub>CYC</sub> *	—	ns	
SCK ↓ → SOD delay time delay time	t <sub>SLOV</sub>	—		—	150	ns	
Valid SID → SCK ↑	t <sub>IVSH</sub>	—		60	—	ns	
SCK ↑ → Valid SID hold time	t <sub>SHIX</sub>	—		60	—	ns	

\* : For information on t<sub>CYC</sub> (cycle time), see "(2) Clock Output Timing."

- Notes:
- These are the AC characteristics for CLK synchronous mode.
  - C<sub>L</sub> is the load capacitance added to pins during testing.

- Internal shift clock mode

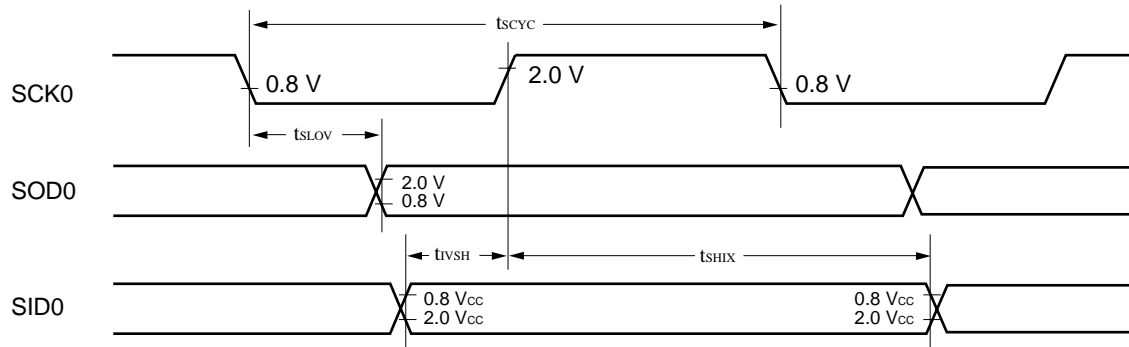

- External shift clock mode

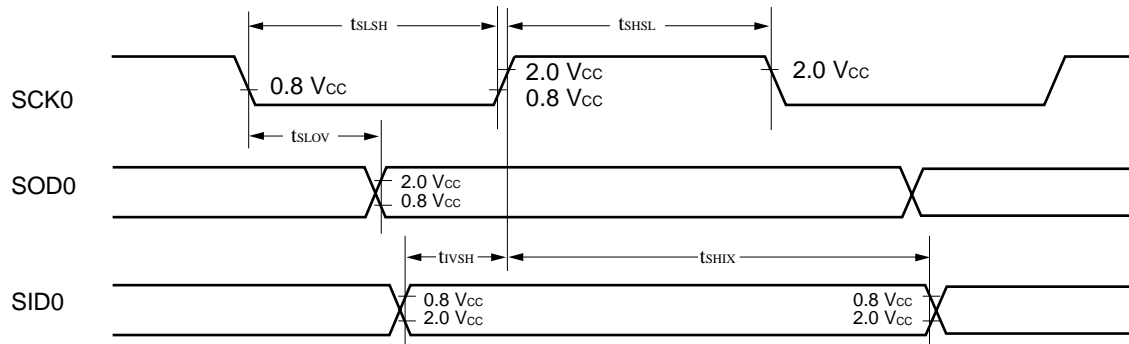

## (10) Serial I/O Timing

( $V_{CC} = 3.3\text{ V} \pm 0.3\text{ V}$ ,  $V_{CC5} = 5.0\text{ V} \pm 0.5\text{ V}$ ,  $A_{VSS} = V_{SS} = 0.0\text{ V}$ ,  $T_A = 0^\circ\text{C}$  to  $+70^\circ\text{C}$ )

Parameter	Symbol	Pin name	Condition	Value		Unit	Remarks
				Min.	Max.		
Serial clock cycle time	$t_{SCYC}$	—	For internal shift clock mode output pin, $C_L = 80\text{ pF}$	$2 t_{CYC}^*$	—	ns	
SCK $\uparrow$ $\rightarrow$ SOD delay time	$t_{SLOV}$	—		—	$1 t_{CYC}^*/2$	ns	
Valid SID $\rightarrow$ SCK $\uparrow$	$t_{VSH}$	—		-15	—	ns	
SCK $\uparrow$ $\rightarrow$ Valid SID hold time	$t_{SHIX}$	—		$1/2 t_{CYC}^*$	—	ns	

\* : For information on  $t_{CYC}$  (cycle time), see “(2) Clock Output Timing.”

Note:  $C_L$  is the load capacitance added to pins during testing.

### • Internal shift clock mode

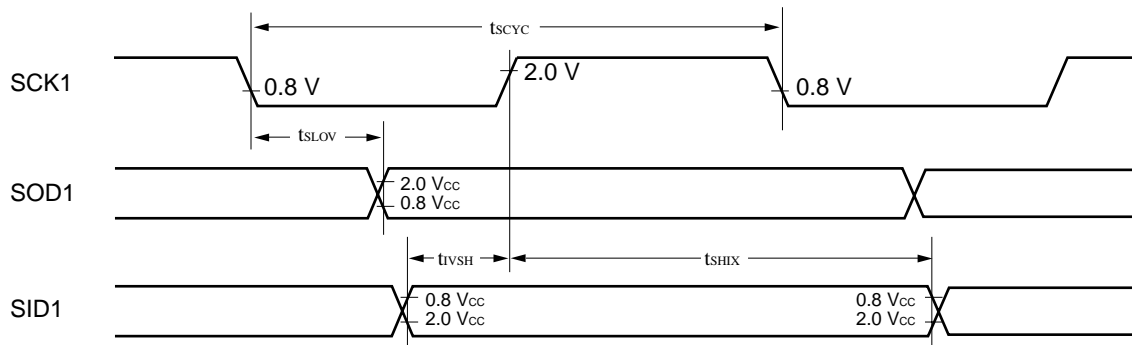

# MB90F244

## (11) Timer Input Timing

( $V_{CC} = 3.0\text{ V} \pm 0.3\text{ V}$ ,  $V_{CC5} = 5.0\text{ V} \pm 0.5\text{ V}$ ,  $A_{V_{SS}} = V_{SS} = 0.0\text{ V}$ ,  $T_A = 0^\circ\text{C}$  to  $+70^\circ\text{C}$ )

Parameter	Symbol	Pin name	Condition	Value		Unit	Remarks
				Min.	Max.		
Input pulse width	$t_{TIWH}$ , $t_{TIWL}$	ASR0 to ASR3, TIN0 to TIN2	—	$4 t_{CYC}^*$	—	ns	

\* : For information on  $t_{CYC}$  (cycle time), see "(2) Clock Output Timing."

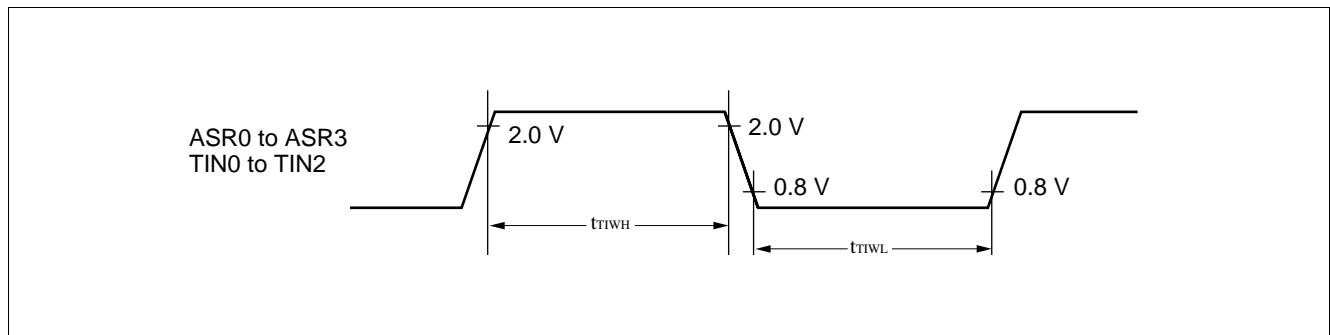

## (12) Timer Output Timing

( $V_{CC} = 3.0\text{ V} \pm 0.3\text{ V}$ ,  $V_{CC5} = 5.0\text{ V} \pm 0.5\text{ V}$ ,  $A_{V_{SS}} = V_{SS} = 0.0\text{ V}$ ,  $T_A = 0^\circ\text{C}$  to  $+70^\circ\text{C}$ )

Parameter	Symbol	Pin name	Condition	Value		Unit	Remarks
				Min.	Max.		
CLK $\uparrow$ → Change time	$t_{ro}$	TOT0 to TOT2	$V_{CC} = 3.3\text{ V} \pm 0.3\text{ V}$	—	40	ns	

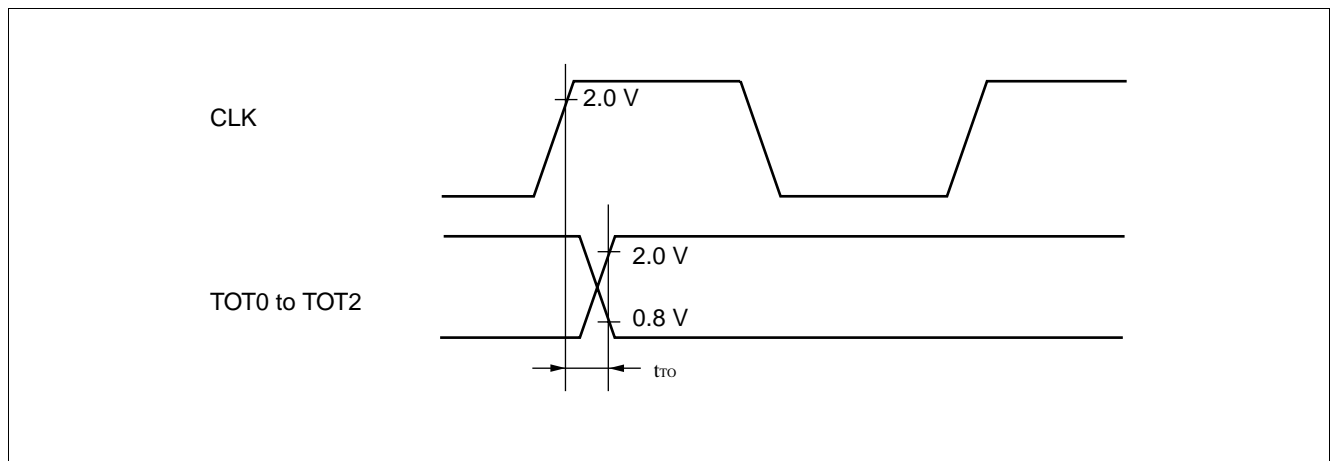

## (13) Trigger Input Timing

( $V_{CC} = 3.0\text{ V} \pm 0.3\text{ V}$ ,  $V_{CC5} = 5.0\text{ V} \pm 0.5\text{ V}$ ,  $A_{V_{SS}} = V_{SS} = 0.0\text{ V}$ ,  $T_A = 0^\circ\text{C}$  to  $+70^\circ\text{C}$ )

Parameter	Symbol	Pin name	Condition	Value		Unit	Remarks
				Min.	Max.		
Input pulse width	$t_{TRGH}$ , $t_{TRGL}$	$\overline{ATG}$ , INT0 to INT3	—	$5 t_{CYC}^*$	—	ns	

\* : For information on  $t_{CYC}$  (cycle time), see "(2) Clock Output Timing."

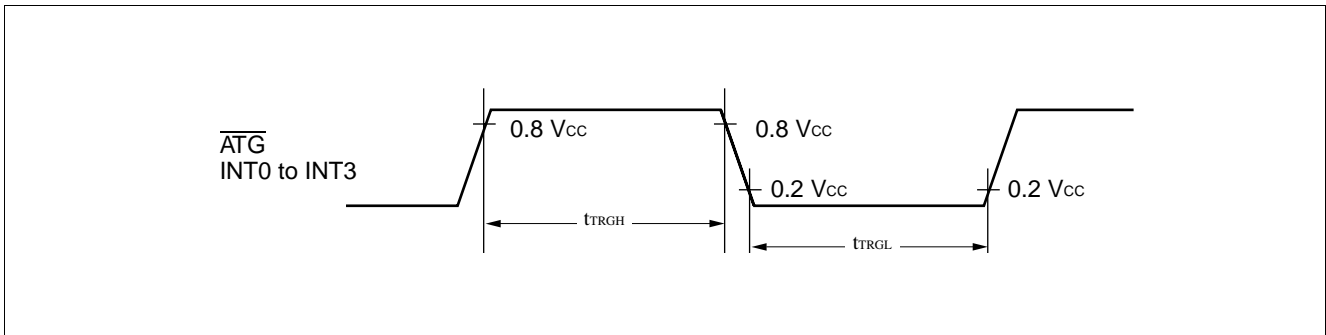

## 6. A/D Converter Electrical Characteristics

( $V_{CC} = 3.3\text{ V} \pm 0.3\text{ V}$ ,  $V_{CC5} = 5.0\text{ V} \pm 0.5\text{ V}$ ,  $AV_{SS} = V_{SS} = 0.0\text{ V}$ ,  $T_A = 0^\circ\text{C}$  to  $+70^\circ\text{C}$ )

Parameter	Symbol	Pin name	Condition	Value			Unit	Remarks
				Min.	Typ.	Max.		
Resolution	—	AN0 to AN3, AN5 to AN7	—	—	8, 10	10	bit	
	—	AN4		—	8	8	bit	
Total error	—	—	—	—	—	T.B.D	LSB	Target: $\pm 4.0$
Linearity error	—	—	—	—	—	T.B.D	LSB	Target: $\pm 2.0$
Differential linearity error	—	—	—	—	—	T.B.D	LSB	Target: $\pm 1.9$
Zero transition voltage	$V_{0T}$	AN0 to AN3, AN5 to AN7	—	AVRL -1.0 LSB	AVRL +1.0 LSB	AVRL +4.0 LSB	mV	
	$V_{0T}$	AN4		AVRL -1.0 LSB	AVRL +1.0 LSB	AVRL +1.5 LSB	mV	8-bit precision in calculation
Full-scale transition voltage	$V_{FST}$	AN0 to AN3, AN5 to AN7	—	AVRH -4.0 LSB	AVRH -1.0 LSB	AVRH +1.0 LSB	mV	
	$V_{FST}$	AN4		AVRH -2.0 LSB	AVRH -1.0 LSB	AVRH +1.0 LSB	mV	8-bit precision in calculation
Conversion time	—	—	Setup by ADCT register $V_{CC} = 3.3\text{ V} \pm 0.3\text{ V}^{*1}$	1.00	—	—	$\mu\text{s}$	
Sampling period	—	—		440	—	—	ns	
Conversion period a	—	—		120	—	—	ns	
Conversion period b	—	—		120	—	—	ns	
Conversion period c	—	—		200	—	—	ns	
Analog port input current	$I_{AIN}$	AN0 to AN7	—	—	0.1	3	$\mu\text{A}$	
Analog input voltage	—	AN0 to AN7	—	AVRL	—	AVRH	V	
Reference voltage	—	AVRH	$AVRH - AVRL \geq 2.7$	AVRL + 2.7	—	$AV_{CC}$	V	
	—	AVRL		0	—	$AVRH - 2.7$	V	
Power supply current	$I_A$	$AV_{CC}$	$AV_{CC} = 3.3\text{ V} \pm 0.3\text{ V}$	—	7	9	mA	
			$AV_{CC} = 3.3\text{ V} \pm 0.15\text{ V}$	—	7	8	mA	
	$I_{AS}^{*2}$	—	$AV_{CC} = 3.3\text{ V}$ Stop mode	—	—	5	$\mu\text{A}$	
Reference voltage supply current	$I_R$	AVRH	$AV_{CC} = 3.3\text{ V}$ Stop mode	—	1.0	1.5	mA	
	$I_{RS}^{*2}$	AVRH		—	—	5	$\mu\text{A}$	
Interchannel disparity	—	AN0 to AN3, AN5 to AN7	—	—	—	4	LSB	No rating for AN4 because of calculated by 8-bit precision

\*1: When  $F_c = 50\text{ MHz}$  (frequency), and the machine cycle is  $4.0\text{ ns}$ .

The minimum value of the ADCT resistor is #A224, differs from that of the MB90F243.

\*2: Current when the A/D converter is not operating and the CPU is stopped.

Notes: • The smaller  $|AVRH - AVRL|$ , the greater the error would become relatively.

- If the output impedance of the external circuit for the analog input is high, sampling period might be insufficient. When the sampling period set at near the minimum value, the output impedance of the external circuit should be less than approximately  $300\ \Omega$ .



• Analog input circuit model diagram

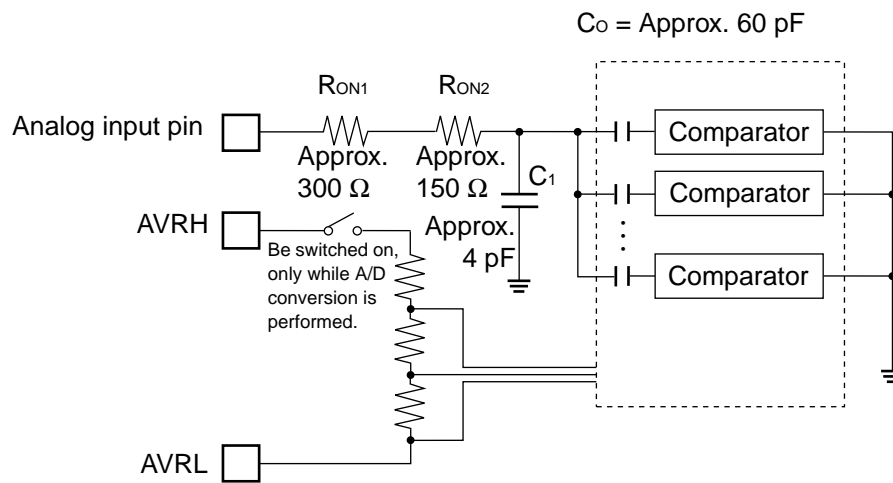

Note: Use the values shows as reference only.

## 6. A/D Converter Glossary

- **Resolution**

Analog changes that are identifiable with the A/D converter.  
When the number of bits is 10, analog voltage can be divide into  $2^{10}$ .

- **Linearity error (unit: LSB)**

The deviation of the straight line connecting the zero transition point (“00 0000 0000” ↔ “00 0000 0001”) with the full-scale transition point (“11 1111 1110” ↔ “11 1111 1111”) from actual conversion characteristics

- **Differential linearity error**

The deviation of input voltage needed to change the output code by 1 LSB from the theoretical value

- **Total error (unit: LSB)**

The difference between theoretical and actual conversion values caused by the zero transition error, full-scale transition error, non-linearity error, differential linearity error, and noise

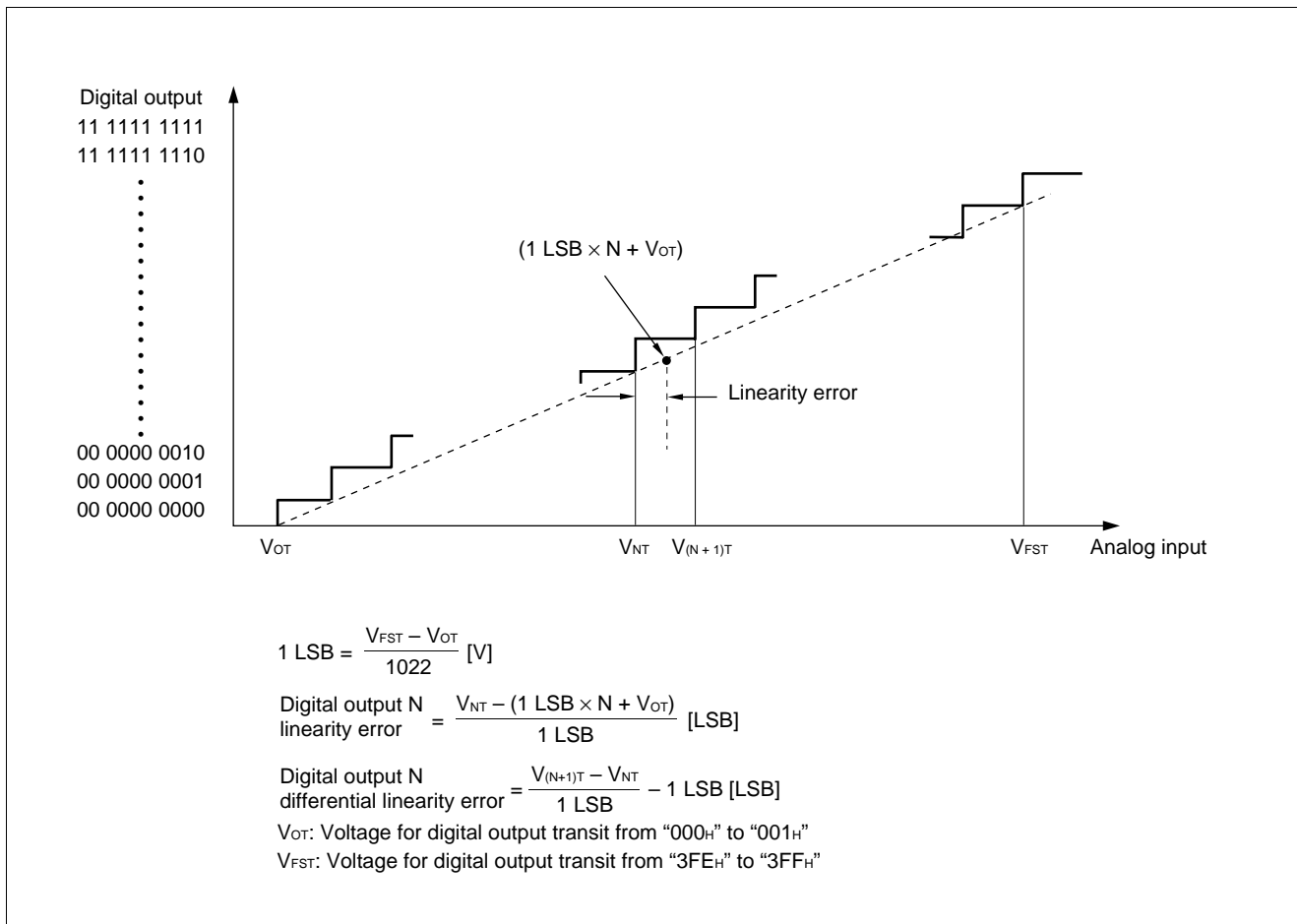

## ■ INSTRUCTIONS (412 INSTRUCTIONS)

**Table 1 Explanation of Items in Table of Instructions**

Item	Explanation
Mnemonic	Upper-case letters and symbols: Represented as they appear in assembler Lower-case letters: Replaced when described in assembler. Numbers after lower-case letters: Indicate the bit width within the instruction.
#	Indicates the number of bytes.
~	Indicates the number of cycles. See Table 4 for details about meanings of letters in items.
B	Indicates the correction value for calculating the number of actual cycles during execution of instruction. The number of actual cycles during execution of instruction is summed with the value in the "cycles" column.
Operation	Indicates operation of instruction.
LH	Indicates special operations involving the bits 15 through 08 of the accumulator. Z: Transfers "0". X: Extends before transferring. —: Transfers nothing.
AH	Indicates special operations involving the high-order 16 bits in the accumulator. *: Transfers from AL to AH. —: No transfer. Z: Transfers 00 <sub>H</sub> to AH. X: Transfers 00 <sub>H</sub> or FF <sub>H</sub> to AH by extending AL.
I	Indicates the status of each of the following flags: I (interrupt enable), S (stack), T (sticky bit), N (negative), Z (zero), V (overflow), and C (carry). *: Changes due to execution of instruction. —: No change. S: Set by execution of instruction. R: Reset by execution of instruction.
S	
T	
N	
Z	
V	
C	
RMW	Indicates whether the instruction is a read-modify-write instruction (a single instruction that reads data from memory, etc., processes the data, and then writes the result to memory). *: Instruction is a read-modify-write instruction —: Instruction is not a read-modify-write instruction Note: Cannot be used for addresses that have different meanings depending on whether they are read or written.

**Table 2 Explanation of Symbols in Table of Instructions**

Symbol	Explanation
A	32-bit accumulator The number of bits used varies according to the instruction. Byte: Low order 8 bits of AL Word: 16 bits of AL Long: 32 bits of AL, AH
AH	High-order 16 bits of A
AL	Low-order 16 bits of A
SP	Stack pointer (USP or SSP)
PC	Program counter
SPCU	Stack pointer upper limit register
SPCL	Stack pointer lower limit register
PCB	Program bank register
DTB	Data bank register
ADB	Additional data bank register
SSB	System stack bank register
USB	User stack bank register
SPB	Current stack bank register (SSB or USB)
DPR	Direct page register
brg1	DTB, ADB, SSB, USB, DPR, PCB, SPB
brg2	DTB, ADB, SSB, USB, DPR, SPB
Ri	R0, R1, R2, R3, R4, R5, R6, R7
RWi	RW0, RW1, RW2, RW3, RW4, RW5, RW6, RW7
RWj	RW0, RW1, RW2, RW3
RLi	RL0, RL1, RL2, RL3
dir	Compact direct addressing
addr16	Direct addressing
addr24	Physical direct addressing
addr24 0 to 15	Bits 0 to 15 of addr24
addr24 16 to 23	Bits 16 to 23 of addr24
io	I/O area (000000 <sub>H</sub> to 0000FF <sub>H</sub> )

(Continued)

(Continued)

Symbol	Explanation
#imm4 #imm8 #imm16 #imm32 ext (imm8)	4-bit immediate data 8-bit immediate data 16-bit immediate data 32-bit immediate data 16-bit data signed and extended from 8-bit immediate data
disp8 disp16	8-bit displacement 16-bit displacement
bp	Bit offset value
vct4 vct8	Vector number (0 to 15) Vector number (0 to 255)
( )b	Bit address
rel ear eam	Branch specification relative to PC Effective addressing (codes 00 to 07) Effective addressing (codes 08 to 1F)
rlst	Register list

**Table 3 Effective Address Fields**

Code	Notation	Address format	Number of bytes in address extension*
00 01 02 03 04 05 06 07	R0 RW0 RL0 R1 RW1 (RL0) R2 RW2 RL1 R3 RW3 (RL1) R4 RW4 RL2 R5 RW5 (RL2) R6 RW6 RL3 R7 RW7 (RL3)	Register direct “ea” corresponds to byte, word, and long-word types, starting from the left	—
08 09 0A 0B	@RW0 @RW1 @RW2 @RW3	Register indirect	0
0C 0D 0E 0F	@RW0 + @RW1 + @RW2 + @RW3 +	Register indirect with post-increment	0
10 11 12 13 14 15 16 17	@RW0 + disp8 @RW1 + disp8 @RW2 + disp8 @RW3 + disp8 @RW4 + disp8 @RW5 + disp8 @RW6 + disp8 @RW7 + disp8	Register indirect with 8-bit displacement	1
18 19 1A 1B	@RW0 + disp16 @RW1 + disp16 @RW2 + disp16 @RW3 + disp16	Register indirect with 16-bit displacement	2
1C 1D 1E 1F	@RW0 + RW7 @RW1 + RW7 @PC + dip16 addr16	Register indirect with index Register indirect with index PC indirect with 16-bit displacement Direct address	0 0 2 2

\* : The number of bytes for address extension is indicated by the “+” symbol in the “#” (number of bytes) column in the Table of Instructions.

**Table 4 Number of Execution Cycles for Each Form of Addressing**

Code	Operand	(a)*
		Number of execution cycles for each from of addressing
00 to 07	Ri RWi RLi	Listed in Table of Instructions
08 to 0B	@RWj	1
0C to 0F	@RWj +	4
10 to 17	@RWi + disp8	1
18 to 1B	@RWj + disp16	1
1C	@RW0 + RW7	2
1D	@RW1 + RW7	2
1E	@PC + dip16	2
1F	@addr16	1

\* :“(a)” is used in the “cycles” (number of cycles) column and column B (correction value) in the Table of Instructions.

**Table 5 Correction Values for Number of Cycles Used to Calculate Number of Actual Cycles**

Operand	(b)*	(c)*	(d)*
	byte	word	long
Internal register	+ 0	+ 0	+ 0
Internal RAM even address	+ 0	+ 0	+ 0
Internal RAM odd address	+ 0	+ 1	+ 2
Even address not in internal RAM	+ 1	+ 1	+ 2
Odd address not in internal RAM	+ 1	+ 3	+ 6
External data bus (8 bits)	+ 1	+ 3	+ 6

\* :“(b)”, “(c)”, and “(d)” are used in the “cycles” (number of cycles) column and column B (correction value) in the Table of Instructions.

**Table 6 Transfer Instructions (Byte) [50 Instructions]**

Mnemonic	#	~	B	Operation	LH	AH	I	S	T	N	Z	V	C	RMW
MOV A, dir	2	2	(b)	byte (A) ← (dir)	Z	*	—	—	—	*	*	—	—	—
MOV A, addr16	3	2	(b)	byte (A) ← (addr16)	Z	*	—	—	—	*	*	—	—	—
MOV A, Ri	1	1	0	byte (A) ← (Ri)	Z	*	—	—	—	*	*	—	—	—
MOV A, ear	2	1	0	byte (A) ← (ear)	Z	*	—	—	—	*	*	—	—	—
MOV A, eam	2+	2+ (a)	(b)	byte (A) ← (eam)	Z	*	—	—	—	*	*	—	—	—
MOV A, io	2	2	(b)	byte (A) ← (io)	Z	*	—	—	—	*	*	—	—	—
MOV A, #imm8	2	2	0	byte (A) ← imm8	Z	*	—	—	—	*	*	—	—	—
MOV A, @A	2	2	(b)	byte (A) ← ((A))	Z	—	—	—	—	*	*	—	—	—
MOV A, @RLi+disp8	3	6	(b)	byte (A) ← ((RLi))+disp8)	Z	*	—	—	—	*	*	—	—	—
MOV A, @SP+disp8	3	3	(b)	byte (A) ← ((SP)+disp8)	Z	*	—	—	—	*	*	—	—	—
MOVP A, addr24	5	3	(b)	byte (A) ← (addr24)	Z	*	—	—	—	*	*	—	—	—
MOVP A, @A	2	2	(b)	byte (A) ← ((A))	Z	—	—	—	—	*	*	—	—	—
MOVN A, #imm4	1	1	0	byte (A) ← imm4	Z	*	—	—	—	R	*	—	—	—
MOVX A, dir	2	2	(b)	byte (A) ← (dir)	X	*	—	—	—	*	*	—	—	—
MOVX A, addr16	3	2	(b)	byte (A) ← (addr16)	X	*	—	—	—	*	*	—	—	—
MOVX A, Ri	2	1	0	byte (A) ← (Ri)	X	*	—	—	—	*	*	—	—	—
MOVX A, ear	2	1	0	byte (A) ← (ear)	X	*	—	—	—	*	*	—	—	—
MOVX A, eam	2+	2+ (a)	(b)	byte (A) ← (eam)	X	*	—	—	—	*	*	—	—	—
MOVX A, io	2	2	(b)	byte (A) ← (io)	X	*	—	—	—	*	*	—	—	—
MOVX A, #imm8	2	2	0	byte (A) ← imm8	X	*	—	—	—	*	*	—	—	—
MOVX A, @A	2	2	(b)	byte (A) ← ((A))	X	—	—	—	—	*	*	—	—	—
MOVX A, @RWi+disp8	2	3	(b)	byte (A) ← ((RWi))+disp8)	X	*	—	—	—	*	*	—	—	—
MOVX A, @RLi+disp8	3	6	(b)	byte (A) ← ((RLi))+disp8)	X	*	—	—	—	*	*	—	—	—
MOVX A, @SP+disp8	3	3	(b)	byte (A) ← ((SP)+disp8)	X	*	—	—	—	*	*	—	—	—
MOVPX A, addr24	5	3	(b)	byte (A) ← (addr24)	X	*	—	—	—	*	*	—	—	—
MOVPX A, @A	2	2	(b)	byte (A) ← ((A))	X	—	—	—	—	*	*	—	—	—
MOV dir, A	2	2	(b)	byte (dir) ← (A)	—	—	—	—	—	*	*	—	—	—
MOV addr16, A	3	2	(b)	byte (addr16) ← (A)	—	—	—	—	—	*	*	—	—	—
MOV Ri, A	1	1	0	byte (Ri) ← (A)	—	—	—	—	—	*	*	—	—	—
MOV ear, A	2	2	0	byte (ear) ← (A)	—	—	—	—	—	*	*	—	—	—
MOV eam, A	2+	2+ (a)	(b)	byte (eam) ← (A)	—	—	—	—	—	*	*	—	—	—
MOV io, A	2	2	(b)	byte (io) ← (A)	—	—	—	—	—	*	*	—	—	—
MOV @RLi+disp8, A	3	6	(b)	byte ((RLi) +disp8) ← (A)	—	—	—	—	—	*	*	—	—	—
MOV @SP+disp8, A	3	3	(b)	byte ((SP)+disp8) ← (A)	—	—	—	—	—	*	*	—	—	—
MOVP addr24, A	5	3	(b)	byte (addr24) ← (A)	—	—	—	—	—	*	*	—	—	—
MOV Ri, ear	2	2	0	byte (Ri) ← (ear)	—	—	—	—	—	*	*	—	—	—
MOV Ri, eam	2+	3+ (a)	(b)	byte (Ri) ← (eam)	—	—	—	—	—	*	*	—	—	—
MOVP @A, Ri	2	3	(b)	byte ((A)) ← (Ri)	—	—	—	—	—	*	*	—	—	—
MOV ear, Ri	2	3	0	byte (ear) ← (Ri)	—	—	—	—	—	*	*	—	—	—
MOV eam, Ri	2+	3+ (a)	(b)	byte (eam) ← (Ri)	—	—	—	—	—	*	*	—	—	—
MOV Ri, #imm8	2	2	0	byte (Ri) ← imm8	—	—	—	—	—	*	*	—	—	—
MOV io, #imm8	3	3	(b)	byte (io) ← imm8	—	—	—	—	—	—	—	—	—	—
MOV dir, #imm8	3	3	(b)	byte (dir) ← imm8	—	—	—	—	—	—	—	—	—	—
MOV ear, #imm8	3	2	0	byte (ear) ← imm8	—	—	—	—	—	*	*	—	—	—
MOV eam, #imm8	3+	2+ (a)	(b)	byte (eam) ← imm8	—	—	—	—	—	—	—	—	—	—
MOV @AL, AH	2	2	(b)	byte ((A)) ← (AH)	—	—	—	—	—	*	*	—	—	—

(Continued)



(Continued)

Mnemonic		#	~	B	Operation	LH	AH	I	S	T	N	Z	V	C	RMW
XCH	A, ear	2	3	0	byte (A) ↔ (ear)	Z	-	-	-	-	-	-	-	-	-
XCH	A, eam	2+	3+ (a)	2× (b)	byte (A) ↔ (eam)	Z	-	-	-	-	-	-	-	-	-
XCH	Ri, ear	2	4	0	byte (Ri) ↔ (ear)	-	-	-	-	-	-	-	-	-	-
XCH	Ri, eam	2+	5+ (a)	2× (b)	byte (Ri) ↔ (eam)	-	-	-	-	-	-	-	-	-	-

For an explanation of “(a)” and “(b)”, refer to Table 4, “Number of Execution Cycles for Each Form of Addressing,” and Table 5, “Correction Values for Number of Cycles Used to Calculate Number of Actual Cycles.”

**Table 7 Transfer Instructions (Word) [40 Instructions]**

Mnemonic	#	~	B	Operation	LH	AH	I	S	T	N	Z	V	C	RMW
MOVW A, dir	2	2	(c)	word (A) ← (dir)	—	*	—	—	—	*	*	—	—	—
MOVW A, addr16	3	2	(c)	word (A) ← (addr16)	—	*	—	—	—	*	*	—	—	—
MOVW A, SP	1	2	0	word (A) ← (SP)	—	*	—	—	—	*	*	—	—	—
MOVW A, RWi	1	1	0	word (A) ← (RWi)	—	*	—	—	—	*	*	—	—	—
MOVW A, ear	2	1	0	word (A) ← (ear)	—	*	—	—	—	*	*	—	—	—
MOVW A, eam	2+	2+ (a)	(c)	word (A) ← (eam)	—	*	—	—	—	*	*	—	—	—
MOVW A, io	2	2	(c)	word (A) ← (io)	—	*	—	—	—	*	*	—	—	—
MOVW A, @A	2	2	(c)	word (A) ← ((A))	—	—	—	—	—	*	*	—	—	—
MOVW A, #imm16	3	2	0	word (A) ← imm16	—	*	—	—	—	*	*	—	—	—
MOVW A, @RWi+disp8	2	3	(c)	word (A) ← ((RWi) +disp8)	—	*	—	—	—	*	*	—	—	—
MOVW A, @RLi+disp8	3	6	(c)	word (A) ← ((RLi) +disp8)	—	*	—	—	—	*	*	—	—	—
MOVW A, @SP+disp8	3	3	(c)	word (A) ← ((SP) +disp8)	—	*	—	—	—	*	*	—	—	—
MOVPWA, addr24	5	3	(c)	word (A) ← (addr24)	—	*	—	—	—	*	*	—	—	—
MOVPWA, @A	2	2	(c)	word (A) ← ((A))	—	—	—	—	—	*	*	—	—	—
MOVW dir, A	2	2	(c)	word (dir) ← (A)	—	—	—	—	—	*	*	—	—	—
MOVW addr16, A	3	2	(c)	word (addr16) ← (A)	—	—	—	—	—	*	*	—	—	—
MOVW SP, # imm16	4	2	0	word (SP) ← imm16	—	—	—	—	—	*	*	—	—	—
MOVW SP, A	1	2	0	word (SP) ← (A)	—	—	—	—	—	*	*	—	—	—
MOVW RWi, A	1	1	0	word (RWi) ← (A)	—	—	—	—	—	*	*	—	—	—
MOVW ear, A	2	2	0	word (ear) ← (A)	—	—	—	—	—	*	*	—	—	—
MOVW eam, A	2+	2+ (a)	(c)	word (eam) ← (A)	—	—	—	—	—	*	*	—	—	—
MOVW io, A	2	2	(c)	word (io) ← (A)	—	—	—	—	—	*	*	—	—	—
MOVW @RWi+disp8, A	2	3	(c)	word ((RWi) +disp8) ← (A)	—	—	—	—	—	*	*	—	—	—
MOVW @RLi+disp8, A	3	6	(c)	word ((RLi) +disp8) ← (A)	—	—	—	—	—	*	*	—	—	—
MOVW @SP+disp8, A	3	3	(c)	word ((SP) +disp8) ← (A)	—	—	—	—	—	*	*	—	—	—
MOVPWaddr24, A	5	3	(c)	word (addr24) ← (A)	—	—	—	—	—	*	*	—	—	—
MOVPW @A, RWi	2	3	(c)	word ((A)) ← (RWi)	—	—	—	—	—	*	*	—	—	—
MOVW RWi, ear	2	2	0	word (RWi) ← (ear)	—	—	—	—	—	*	*	—	—	—
MOVW RWi, eam	2+	3+ (a)	(c)	word (RWi) ← (eam)	—	—	—	—	—	*	*	—	—	—
MOVW ear, RWi	2	3	0	word (ear) ← (RWi)	—	—	—	—	—	*	*	—	—	—
MOVW eam, RWi	2+	3+ (a)	(c)	word (eam) ← (RWi)	—	—	—	—	—	*	*	—	—	—
MOVW RWi, #imm16	3	2	0	word (RWi) ← imm16	—	—	—	—	—	*	*	—	—	—
MOVW io, #imm16	4	3	(c)	word (io) ← imm16	—	—	—	—	—	—	—	—	—	—
MOVW ear, #imm16	4	2	0	word (ear) ← imm16	—	—	—	—	—	*	*	—	—	—
MOVW eam, #imm16	4+	2+ (a)	(c)	word (eam) ← imm16	—	—	—	—	—	—	—	—	—	—
MOVW @AL, AH	2	2	(c)	word ((A)) ← (AH)	—	—	—	—	—	*	*	—	—	—
XCHW A, ear	2	3	0	word (A) ↔ (ear)	—	—	—	—	—	—	—	—	—	—
XCHW A, eam	2+	3+ (a)	2× (c)	word (A) ↔ (eam)	—	—	—	—	—	—	—	—	—	—
XCHW RWi, ear	2	4	0	word (RWi) ↔ (ear)	—	—	—	—	—	—	—	—	—	—
XCHW RWi, eam	2+	5+ (a)	2× (c)	word (RWi) ↔ (eam)	—	—	—	—	—	—	—	—	—	—

Note: For an explanation of “(a)” and “(c)”, refer to Table 4, “Number of Execution Cycles for Each Form of Addressing,” and Table 5, “Correction Values for Number of Cycles Used to Calculate Number of Actual Cycles.”

**Table 8 Transfer Instructions (Long Word) [11 Instructions]**

Mnemonic	#	~	B	Operation	LH	AH	I	S	T	N	Z	V	C	RMW
MOVL A, ear	2	1	0	long (A) ← (ear)	–	–	–	–	–	*	*	–	–	–
MOVL A, eam	2+	3+ (a)	(d)	long (A) ← (eam)	–	–	–	–	–	*	*	–	–	–
MOVL A, # imm32	5	3	0	long (A) ← imm32	–	–	–	–	–	*	*	–	–	–
MOVL A, @SP + disp8	3	4	(d)	long (A) ← ((SP) + disp8)	–	–	–	–	–	*	*	–	–	–
MOVPL A, addr24	5	4	(d)	long (A) ← (addr24)	–	–	–	–	–	*	*	–	–	–
MOVPL A, @A	2	3	(d)	long (A) ← ((A))	–	–	–	–	–	*	*	–	–	–
MOVPL @A, RLi	2	5	(d)	long ((A)) ← (RLi)	–	–	–	–	–	*	*	–	–	–
MOVL @SP + disp8, A	3	4	(d)	long ((SP) + disp8) ← (A)	–	–	–	–	–	*	*	–	–	–
MOVPL addr24, A	5	4	(d)	long (addr24) ← (A)	–	–	–	–	–	*	*	–	–	–
MOVL ear, A	2	2	0	long (ear) ← (A)	–	–	–	–	–	*	*	–	–	–
MOVL eam, A	2+	3+ (a)	(d)	long (eam) ← (A)	–	–	–	–	–	*	*	–	–	–

For an explanation of “(a)” and “(d)”, refer to Table 4, “Number of Execution Cycles for Each Form of Addressing,” and Table 5, “Correction Values for Number of Cycles Used to Calculate Number of Actual Cycles.”

**Table 9 Addition and Subtraction Instructions (Byte/Word/Long Word) [42 Instructions]**

Mnemonic	#	~	B	Operation	LH	AH	I	S	T	N	Z	V	C	RMW
ADD A, #imm8	2	2	0	byte (A) ← (A) + imm8	Z	—	—	—	—	*	*	*	*	—
ADD A, dir	2	3	(b)	byte (A) ← (A) + (dir)	Z	—	—	—	—	*	*	*	*	—
ADD A, ear	2	2	0	byte (A) ← (A) + (ear)	Z	—	—	—	—	*	*	*	*	—
ADD A, eam	2+	3+ (a)	(b)	byte (A) ← (A) + (eam)	Z	—	—	—	—	*	*	*	*	—
ADD ear, A	2	2	0	byte (ear) ← (ear) + (A)	—	—	—	—	—	*	*	*	*	*
ADD eam, A	2+	3+ (a)	2× (b)	byte (eam) ← (eam) + (A)	Z	—	—	—	—	*	*	*	*	*
ADDC A	1	2	0	byte (A) ← (AH) + (AL) + (C)	Z	—	—	—	—	*	*	*	*	—
ADDC A, ear	2	2	0	byte (A) ← (A) + (ear) + (C)	Z	—	—	—	—	*	*	*	*	—
ADDC A, eam	2+	3+ (a)	(b)	byte (A) ← (A) + (eam) + (C)	Z	—	—	—	—	*	*	*	*	—
ADDC A	1	3	0	byte (A) ← (AH) + (AL) + (C) (Decimal)	Z	—	—	—	—	*	*	*	*	—
SUB A, #imm8	2	2	0	byte (A) ← (A) – imm8	Z	—	—	—	—	*	*	*	*	—
SUB A, dir	2	3	(b)	byte (A) ← (A) – (dir)	Z	—	—	—	—	*	*	*	*	—
SUB A, ear	2	2	0	byte (A) ← (A) – (ear)	Z	—	—	—	—	*	*	*	*	—
SUB A, eam	2+	3+ (a)	(b)	byte (A) ← (A) – (eam)	Z	—	—	—	—	*	*	*	*	—
SUB ear, A	2	2	0	byte (ear) ← (ear) – (A)	—	—	—	—	—	*	*	*	*	*
SUB eam, A	2+	3+ (a)	2× (b)	byte (eam) ← (eam) – (A)	—	—	—	—	—	*	*	*	*	*
SUBC A	1	2	0	byte (A) ← (AH) – (AL) – (C)	Z	—	—	—	—	*	*	*	*	—
SUBC A, ear	2	2	0	byte (A) ← (A) – (ear) – (C)	Z	—	—	—	—	*	*	*	*	—
SUBC A, eam	2+	3+ (a)	(b)	byte (A) ← (A) – (eam) – (C)	Z	—	—	—	—	*	*	*	*	—
SUBC A	1	3	0	byte (A) ← (AH) – (AL) – (C) (Decimal)	Z	—	—	—	—	*	*	*	*	—
ADDW A	1	2	0	word (A) ← (AH) + (AL)	—	—	—	—	—	*	*	*	*	—
ADDW A, ear	2	2	0	word (A) ← (A) + (ear)	—	—	—	—	—	*	*	*	*	—
ADDW A, eam	2+	3+ (a)	(c)	word (A) ← (A) + (eam)	—	—	—	—	—	*	*	*	*	—
ADDW A, #imm16	3	2	0	word (A) ← (A) + imm16	—	—	—	—	—	*	*	*	*	—
ADDW ear, A	2	2	0	word (ear) ← (ear) + (A)	—	—	—	—	—	*	*	*	*	*
ADDW eam, A	2+	3+ (a)	2× (c)	word (eam) ← (eam) + (A)	—	—	—	—	—	*	*	*	*	*
ADDCW A, ear	2	2	0	word (A) ← (A) + (ear) + (C)	—	—	—	—	—	*	*	*	*	—
ADDCW A, eam	2+	3+ (a)	(c)	word (A) ← (A) + (eam) + (C)	—	—	—	—	—	*	*	*	*	—
SUBW A	1	2	0	word (A) ← (AH) – (AL)	—	—	—	—	—	*	*	*	*	—
SUBW A, ear	2	2	0	word (A) ← (A) – (ear)	—	—	—	—	—	*	*	*	*	—
SUBW A, eam	2+	3+ (a)	(c)	word (A) ← (A) – (eam)	—	—	—	—	—	*	*	*	*	—
SUBW A, #imm16	3	2	0	word (A) ← (A) – imm16	—	—	—	—	—	*	*	*	*	—
SUBW ear, A	2	2	0	word (ear) ← (ear) – (A)	—	—	—	—	—	*	*	*	*	*
SUBW eam, A	2+	3+ (a)	2× (c)	word (eam) ← (eam) – (A)	—	—	—	—	—	*	*	*	*	*
SUBCW A, ear	2	2	0	word (A) ← (A) – (ear) – (C)	—	—	—	—	—	*	*	*	*	—
SUBCW A, eam	2+	3+ (a)	(c)	word (A) ← (A) – (eam) – (C)	—	—	—	—	—	*	*	*	*	—
ADDL A, ear	2	5	0	long (A) ← (A) + (ear)	—	—	—	—	—	*	*	*	*	—
ADDL A, eam	2+	6+ (a)	(d)	long (A) ← (A) + (eam)	—	—	—	—	—	*	*	*	*	—
ADDL A, #imm32	5	4	0	long (A) ← (A) + imm32	—	—	—	—	—	*	*	*	*	—
SUBL A, ear	2	5	0	long (A) ← (A) – (ear)	—	—	—	—	—	*	*	*	*	—
SUBL A, eam	2+	6+ (a)	(d)	long (A) ← (A) – (eam)	—	—	—	—	—	*	*	*	*	—
SUBL A, #imm32	5	4	0	long (A) ← (A) – imm32	—	—	—	—	—	*	*	*	*	—

For an explanation of “(a)”, “(b)”, “(c)” and “(d)”, refer to Table 4, “Number of Execution Cycles for Each Form of Addressing,” and Table 5, “Correction Values for Number of Cycles Used to Calculate Number of Actual Cycles.”

**Table 10 Increment and Decrement Instructions (Byte/Word/Long Word) [12 Instructions]**

Mnemonic	#	~	B	Operation	LH	AH	I	S	T	N	Z	V	C	RMW
INC ear	2	2	0	byte (ear) ← (ear) +1	–	–	–	–	–	*	*	*	–	*
INC eam	2+	3+ (a)	2× (b)	byte (eam) ← (eam) +1	–	–	–	–	–	*	*	*	–	*
DEC ear	2	2	0	byte (ear) ← (ear) –1	–	–	–	–	–	*	*	*	–	*
DEC eam	2+	3+ (a)	2× (b)	byte (eam) ← (eam) –1	–	–	–	–	–	*	*	*	–	*
INCW ear	2	2	0	word (ear) ← (ear) +1	–	–	–	–	–	*	*	*	–	*
INCW eam	2+	3+ (a)	2× (c)	word (eam) ← (eam) +1	–	–	–	–	–	*	*	*	–	*
DECW ear	2	2	0	word (ear) ← (ear) –1	–	–	–	–	–	*	*	*	–	*
DECW eam	2+	3+ (a)	2× (c)	word (eam) ← (eam) –1	–	–	–	–	–	*	*	*	–	*
INCL ear	2	4	0	long (ear) ← (ear) +1	–	–	–	–	–	*	*	*	–	*
INCL eam	2+	5+ (a)	2× (d)	long (eam) ← (eam) +1	–	–	–	–	–	*	*	*	–	*
DECL ear	2	4	0	long (ear) ← (ear) –1	–	–	–	–	–	*	*	*	–	*
DECL eam	2+	5+ (a)	2× (d)	long (eam) ← (eam) –1	–	–	–	–	–	*	*	*	–	*

For an explanation of “(a)”, “(b)”, “(c)” and “(d)”, refer to Table 4, “Number of Execution Cycles for Each Form of Addressing,” and Table 5, “Correction Values for Number of Cycles Used to Calculate Number of Actual Cycles.”

**Table 11 Compare Instructions (Byte/Word/Long Word) [11 Instructions]**

Mnemonic	#	~	B	Operation	LH	AH	I	S	T	N	Z	V	C	RMW
CMP A	1	2	0	byte (AH) – (AL)	–	–	–	–	–	*	*	*	*	–
CMP A, ear	2	2	0	byte (A) – (ear)	–	–	–	–	–	*	*	*	*	–
CMP A, eam	2+	2+ (a)	(b)	byte (A) – (eam)	–	–	–	–	–	*	*	*	*	–
CMP A, #imm8	2	2	0	byte (A) – imm8	–	–	–	–	–	*	*	*	*	–
CMPW A	1	2	0	word (AH) – (AL)	–	–	–	–	–	*	*	*	*	–
CMPW A, ear	2	2	0	word (A) – (ear)	–	–	–	–	–	*	*	*	*	–
CMPW A, eam	2+	2+ (a)	(c)	word (A) – (eam)	–	–	–	–	–	*	*	*	*	–
CMPW A, #imm16	3	2	0	word (A) – imm16	–	–	–	–	–	*	*	*	*	–
CMPL A, ear	2	3	0	long (A) – (ear)	–	–	–	–	–	*	*	*	*	–
CMPL A, eam	2+	4+ (a)	(d)	long (A) – (eam)	–	–	–	–	–	*	*	*	*	–
CMPL A, #imm32	5	3	0	long (A) – imm32	–	–	–	–	–	*	*	*	*	–

For an explanation of “(a)”, “(b)”, “(c)” and “(d)”, refer to Table 4, “Number of Execution Cycles for Each Form of Addressing,” and Table 5, “Correction Values for Number of Cycles Used to Calculate Number of Actual Cycles.”

**Table 12 Unsigned Multiplication and Division Instructions (Word/Long Word) [11 Instructions]**

Mnemonic	#	~	B	Operation	LH	AH	I	S	T	N	Z	V	C	RMW
DIVU A	1	*1	0	word (AH) /byte (AL) Quotient → byte (AL) Remainder → byte (AH)	-	-	-	-	-	-	-	*	*	-
DIVU A, ear	2	*2	0	word (A)/byte (ear) Quotient → byte (A) Remainder → byte (ear)	-	-	-	-	-	-	-	*	*	-
DIVU A, eam	2+	*3	*6	word (A)/byte (eam) Quotient → byte (A) Remainder → byte (eam)	-	-	-	-	-	-	-	*	*	-
DIVUW A, ear	2	*4	0	long (A)/word (ear) Quotient → word (A) Remainder → word (ear)	-	-	-	-	-	-	-	*	*	-
DIVUW A, eam	2+	*5	*7	long (A)/word (eam) Quotient → word (A) Remainder → word (eam)	-	-	-	-	-	-	-	*	*	-
MULU A	1	*8	0	byte (AH) × byte (AL) → word (A)	-	-	-	-	-	-	-	-	-	-
MULU A, ear	2	*9	0	byte (A) × byte (ear) → word (A)	-	-	-	-	-	-	-	-	-	-
MULU A, eam	2+	*10	(b)	byte (A) × byte (eam) → word (A)	-	-	-	-	-	-	-	-	-	-
MULUW A	1	*11	0	word (AH) × word (AL) → long (A)	-	-	-	-	-	-	-	-	-	-
MULUW A, ear	2	*12	0	word (A) × word (ear) → long (A)	-	-	-	-	-	-	-	-	-	-
MULUW A, eam	2+	*13	(c)	word (A) × word (eam) → long (A)	-	-	-	-	-	-	-	-	-	-

For an explanation of “(b)” and “(c), refer to Table 5, “Correction Values for Number of Cycle Used to Calculate Number of Actual Cycles.”

- \*1: 3 when dividing into zero, 6 when an overflow occurs, and 14 normally.
- \*2: 3 when dividing into zero, 5 when an overflow occurs, and 13 normally.
- \*3: 5 + (a) when dividing into zero, 7 + (a) when an overflow occurs, and 17 + (a) normally.
- \*4: 3 when dividing into zero, 5 when an overflow occurs, and 21 normally.
- \*5: 4 + (a) when dividing into zero, 7 + (a) when an overflow occurs, and 25 + (a) normally.
- \*6: (b) when dividing into zero or when an overflow occurs, and 2 × (b) normally.
- \*7: (c) when dividing into zero or when an overflow occurs, and 2 × (c) normally.
- \*8: 3 when byte (AH) is zero, and 7 when byte (AH) is not 0.
- \*9: 3 when byte (ear) is zero, and 7 when byte (ear) is not 0.
- \*10: 4 + (a) when byte (eam) is zero, and 8 + (a) when byte (eam) is not 0.
- \*11: 3 when word (AH) is zero, and 11 when word (AH) is not 0.
- \*12: 3 when word (ear) is zero, and 11 when word (ear) is not 0.
- \*13: 4 + (a) when word (eam) is zero, and 12 + (a) when word (eam) is not 0.

**Table 13 Signed Multiplication and Division Instructions (Word/Long Word) [11 Instructions]**

Mnemonic	#	~	B	Operation	LH	AH	I	S	T	N	Z	V	C	RMW
DIV A	2	*1	0	word (AH) /byte (AL) Quotient → byte (AL) Remainder → byte (AH)	Z	-	-	-	-	-	-	*	*	-
DIV A, ear	2	*2	0	word (A)/byte (ear) Quotient → byte (A) Remainder → byte (ear)	Z	-	-	-	-	-	-	*	*	-
DIV A, eam	2+	*3	*6	word (A)/byte (eam) Quotient → byte (A) Remainder → byte (eam)	Z	-	-	-	-	-	-	*	*	-
DIVW A, ear	2	*4	0	long (A)/word (ear) Quotient → word (A) Remainder → word (ear)	-	-	-	-	-	-	-	*	*	-
DIVW A, eam	2+	*5	*7	long (A)/word (eam) Quotient → word (A) Remainder → word (eam)	-	-	-	-	-	-	-	*	*	-
MUL A	2	*8	0	byte (AH) × byte (AL) → word (A)	-	-	-	-	-	-	-	-	-	-
MUL A, ear	2	*9	0	byte (A) × byte (ear) → word (A)	-	-	-	-	-	-	-	-	-	-
MUL A, eam	2+	*10	(b)	byte (A) × byte (eam) → word (A)	-	-	-	-	-	-	-	-	-	-
MULW A	2	*11	0	word (AH) × word (AL) → long (A)	-	-	-	-	-	-	-	-	-	-
MULW A, ear	2	*12	0	word (A) × word (ear) → long (A)	-	-	-	-	-	-	-	-	-	-
MULW A, eam	2+	*13	(b)	word (A) × word (eam) → long (A)	-	-	-	-	-	-	-	-	-	-

For an explanation of “(b)” and “(c)”, refer to Table 5, “Correction Values for Number of Cycles Used to Calculate Number of Actual Cycles.”

- \*1: 3 when dividing into zero, 8 or 18 when an overflow occurs, and 18 normally.
- \*2: 3 when dividing into zero, 10 or 21 when an overflow occurs, and 22 normally.
- \*3: 4 + (a) when dividing into zero, 11 + (a) or 22 + (a) when an overflow occurs, and 23 + (a) normally.
- \*4: When the dividend is positive: 4 when dividing into zero, 10 or 29 when an overflow occurs, and 30 normally.  
When the dividend is negative: 4 when dividing into zero, 11 or 30 when an overflow occurs, and 31 normally.
- \*5: When the dividend is positive: 4 + (a) when dividing into zero, 11 + (a) or 30 + (a) when an overflow occurs, and 31 + (a) normally.  
When the dividend is negative: 4 + (a) when dividing into zero, 12 + (a) or 31 + (a) when an overflow occurs, and 32 + (a) normally.
- \*6: (b) when dividing into zero or when an overflow occurs, and 2 × (b) normally.
- \*7: (c) when dividing into zero or when an overflow occurs, and 2 × (c) normally.
- \*8: 3 when byte (AH) is zero, 12 when the result is positive, and 13 when the result is negative.
- \*9: 3 when byte (ear) is zero, 12 when the result is positive, and 13 when the result is negative.
- \*10: 4 + (a) when byte (eam) is zero, 13 + (a) when the result is positive, and 14 + (a) when the result is negative.
- \*11: 3 when word (AH) is zero, 12 when the result is positive, and 13 when the result is negative.
- \*12: 3 when word (ear) is zero, 16 when the result is positive, and 19 when the result is negative.
- \*13: 4 + (a) when word (eam) is zero, 17 + (a) when the result is positive, and 20 + (a) when the result is negative.

Note: Which of the two values given for the number of execution cycles applies when an overflow error occurs in a DIV or DIVW instruction depends on whether the overflow was detected before or after the operation.

**Table 14 Logical 1 Instructions (Byte, Word) [39 Instructions]**

Mnemonic	#	~	B	Operation	LH	AH	I	S	T	N	Z	V	C	RMW
AND A, #imm8	2	2	0	byte (A) ← (A) and imm8	-	-	-	-	-	*	*	R	-	-
AND A, ear	2	2	0	byte (A) ← (A) and (ear)	-	-	-	-	-	*	*	R	-	-
AND A, eam	2+	3+ (a)	(b)	byte (A) ← (A) and (eam)	-	-	-	-	-	*	*	R	-	-
AND ear, A	2	3	0	byte (ear) ← (ear) and (A)	-	-	-	-	-	*	*	R	-	*
AND eam, A	2+	3+ (a)	2× (b)	byte (eam) ← (eam) and (A)	-	-	-	-	-	*	*	R	-	*
OR A, #imm8	2	2	0	byte (A) ← (A) or imm8	-	-	-	-	-	*	*	R	-	-
OR A, ear	2	2	0	byte (A) ← (A) or (ear)	-	-	-	-	-	*	*	R	-	-
OR A, eam	2+	3+ (a)	(b)	byte (A) ← (A) or (eam)	-	-	-	-	-	*	*	R	-	-
OR ear, A	2	3	0	byte (ear) ← (ear) or (A)	-	-	-	-	-	*	*	R	-	*
OR eam, A	2+	3+ (a)	2× (b)	byte (eam) ← (eam) or (A)	-	-	-	-	-	*	*	R	-	*
XOR A, #imm8	2	2	0	byte (A) ← (A) xor imm8	-	-	-	-	-	*	*	R	-	-
XOR A, ear	2	2	0	byte (A) ← (A) xor (ear)	-	-	-	-	-	*	*	R	-	-
XOR A, eam	2+	3+ (a)	(b)	byte (A) ← (A) xor (eam)	-	-	-	-	-	*	*	R	-	-
XOR ear, A	2	3	0	byte (ear) ← (ear) xor (A)	-	-	-	-	-	*	*	R	-	*
XOR eam, A	2+	3+ (a)	2× (b)	byte (eam) ← (eam) xor (A)	-	-	-	-	-	*	*	R	-	*
NOT A	1	2	0	byte (A) ← not (A)	-	-	-	-	-	*	*	R	-	-
NOT ear	2	2	0	byte (ear) ← not (ear)	-	-	-	-	-	*	*	R	-	*
NOT eam	2+	3+ (a)	2× (b)	byte (eam) ← not (eam)	-	-	-	-	-	*	*	R	-	*
ANDW A	1	2	0	word (A) ← (AH) and (A)	-	-	-	-	-	*	*	R	-	-
ANDW A, #imm16	3	2	0	word (A) ← (A) and imm16	-	-	-	-	-	*	*	R	-	-
ANDW A, ear	2	2	0	word (A) ← (A) and (ear)	-	-	-	-	-	*	*	R	-	-
ANDW A, eam	2+	3+ (a)	(c)	word (A) ← (A) and (eam)	-	-	-	-	-	*	*	R	-	-
ANDW ear, A	2	3	0	word (ear) ← (ear) and (A)	-	-	-	-	-	*	*	R	-	*
ANDW eam, A	2+	3+ (a)	2× (c)	word (eam) ← (eam) and (A)	-	-	-	-	-	*	*	R	-	*
ORW A	1	2	0	word (A) ← (AH) or (A)	-	-	-	-	-	*	*	R	-	-
ORW A, #imm16	3	2	0	word (A) ← (A) or imm16	-	-	-	-	-	*	*	R	-	-
ORW A, ear	2	2	0	word (A) ← (A) or (ear)	-	-	-	-	-	*	*	R	-	-
ORW A, eam	2+	3+ (a)	(c)	word (A) ← (A) or (eam)	-	-	-	-	-	*	*	R	-	-
ORW ear, A	2	3	0	word (ear) ← (ear) or (A)	-	-	-	-	-	*	*	R	-	*
ORW eam, A	2+	3+ (a)	2× (c)	word (eam) ← (eam) or (A)	-	-	-	-	-	*	*	R	-	*
XORW A	1	2	0	word (A) ← (AH) xor (A)	-	-	-	-	-	*	*	R	-	-
XORW A, #imm16	3	2	0	word (A) ← (A) xor imm16	-	-	-	-	-	*	*	R	-	-
XORW A, ear	2	2	0	word (A) ← (A) xor (ear)	-	-	-	-	-	*	*	R	-	-
XORW A, eam	2+	3+ (a)	(c)	word (A) ← (A) xor (eam)	-	-	-	-	-	*	*	R	-	-
XORW ear, A	2	3	0	word (ear) ← (ear) xor (A)	-	-	-	-	-	*	*	R	-	*
XORW eam, A	2+	3+ (a)	2× (c)	word (eam) ← (eam) xor (A)	-	-	-	-	-	*	*	R	-	*
NOTW A	1	2	0	word (A) ← not (A)	-	-	-	-	-	*	*	R	-	-
NOTW ear	2	2	0	word (ear) ← not (ear)	-	-	-	-	-	*	*	R	-	*
NOTW eam	2+	3+ (a)	2× (c)	word (eam) ← not (eam)	-	-	-	-	-	*	*	R	-	*

For an explanation of “(a)”, “(b)”, “(c)” and “(d)”, refer to Table 4, “Number of Execution Cycles for Each Form of Addressing,” and Table 5, “Correction Values for Number of Cycles Used to Calculate Number of Actual Cycles.”



**Table 15 Logical 2 Instructions (Long Word) [6 Instructions]**

Mnemonic	#	~	B	Operation	LH	AH	I	S	T	N	Z	V	C	RMW
ANDL A, ear	2	5	0	long (A) ← (A) and (ear)	–	–	–	–	–	*	*	R	–	–
ANDL A, eam	2+	6+ (a)	(d)	long (A) ← (A) and (eam)	–	–	–	–	–	*	*	R	–	–
ORL A, ear	2	5	0	long (A) ← (A) or (ear)	–	–	–	–	–	*	*	R	–	–
ORL A, eam	2+	6+ (a)	(d)	long (A) ← (A) or (eam)	–	–	–	–	–	*	*	R	–	–
XORL A, ear	2	5	0	long (A) ← (A) xor (ear)	–	–	–	–	–	*	*	R	–	–
XORL A, eam	2+	6+ (a)	(d)	long (A) ← (A) xor (eam)	–	–	–	–	–	*	*	R	–	–

For an explanation of “(a)” and “(d)”, refer to Table 4, “Number of Execution Cycles for Each Form of Addressing,” and Table 5, “Correction Values for Number of Cycles Used to Calculate Number of Actual Cycles.”

**Table 16 Sign Inversion Instructions (Byte/Word) [6 Instructions]**

Mnemonic	#	~	B	Operation	LH	AH	I	S	T	N	Z	V	C	RMW
NEG A	1	2	0	byte (A) ← 0 – (A)	X	–	–	–	–	*	*	*	*	–
NEG ear	2	2	0	byte (ear) ← 0 – (ear)	–	–	–	–	–	*	*	*	*	*
NEG eam	2+	3+ (a)	2× (b)	byte (eam) ← 0 – (eam)	–	–	–	–	–	*	*	*	*	*
NEGW A	1	2	0	word (A) ← 0 – (A)	–	–	–	–	–	*	*	*	*	–
NEGW ear	2	2	0	word (ear) ← 0 – (ear)	–	–	–	–	–	*	*	*	*	*
NEGW eam	2+	3+ (a)	2× (c)	word (eam) ← 0 – (eam)	–	–	–	–	–	*	*	*	*	*

For an explanation of “(a)”, “(b)” and “(c)” and refer to Table 4, “Number of Execution Cycles for Each Form of Addressing,” and Table 5, “Correction Values for Number of Cycles Used to Calculate Number of Actual Cycles.”

**Table 17 Absolute Value Instructions (Byte/Word/Long Word) [3 Instructions]**

Mnemonic	#	~	B	Operation	LH	AH	I	S	T	N	Z	V	C	RMW
ABS A	2	2	0	byte (A) ← absolute value (A)	Z	–	–	–	–	*	*	*	–	–
ABSW A	2	2	0	word (A) ← absolute value (A)	–	–	–	–	–	*	*	*	–	–
ABSL A	2	4	0	long (A) ← absolute value (A)	–	–	–	–	–	*	*	*	–	–

**Table 18 Normalize Instructions (Long Word) [1 Instruction]**

Mnemonic	#	~	B	Operation	LH	AH	I	S	T	N	Z	V	C	RMW
NRML A, R0	2	*	0	long (A) ← Shifts to the position at which “1” was set first byte (R0) ← current shift count	–	–	–	–	*	–	–	–	–	–

\* : 5 when the contents of the accumulator are all zeroes, 5 + (R0) in all other cases.

**Table 19 Shift Instructions (Byte/Word/Long Word) [27 Instructions]**

Mnemonic	#	~	B	Operation	LH	AH	I	S	T	N	Z	V	C	RMW
RORC A	2	2	0	byte (A) ← Right rotation with carry	—	—	—	—	—	*	*	—	*	—
ROLC A	2	2	0	byte (A) ← Left rotation with carry	—	—	—	—	—	*	*	—	*	—
RORC ear	2	2	0	byte (ear) ← Right rotation with carry	—	—	—	—	—	*	*	—	*	*
RORC eam	2+	3+ (a)	2× (b)	byte (eam) ← Right rotation with carry	—	—	—	—	—	*	*	—	*	*
ROLC ear	2	2	0	byte (ear) ← Left rotation with carry	—	—	—	—	—	*	*	—	*	*
ROLC eam	2+	3+ (a)	2× (b)	byte (eam) ← Left rotation with carry	—	—	—	—	—	*	*	—	*	*
ASR A, R0	2	*1	0	byte (A) ← Arithmetic right barrel shift (A, R0)	—	—	—	—	*	*	*	—	*	—
LSR A, R0	2	*1	0	byte (A) ← Logical right barrel shift (A, R0)	—	—	—	—	*	*	*	—	*	—
LSL A, R0	2	*1	0	byte (A) ← Logical left barrel shift (A, R0)	—	—	—	—	—	*	*	—	*	—
ASR A, #imm8	3	*3	0	byte (A) ← Arithmetic right barrel shift (A, imm8)	—	—	—	—	*	*	*	—	*	—
LSR A, #imm8	3	*3	0	byte (A) ← Logical right barrel shift (A, imm8)	—	—	—	—	*	*	*	—	*	—
LSL A, #imm8	3	*3	0	byte (A) ← Logical left barrel shift (A, imm8)	—	—	—	—	—	*	*	—	*	—
ASRW A	1	2	0	word (A) ← Arithmetic right shift (A, 1 bit)	—	—	—	—	*	*	*	—	*	—
LSRW A/SHRW A	1	2	0	word (A) ← Logical right shift (A, 1 bit)	—	—	—	—	*	R	*	—	*	—
LSLW A/SHLW A	1	2	0	word (A) ← Logical left shift (A, 1 bit)	—	—	—	—	—	*	*	—	*	—
ASRW A, R0	2	*1	0	word (A) ← Arithmetic right barrel shift (A, R0)	—	—	—	—	*	*	*	—	*	—
LSRW A, R0	2	*1	0	word (A) ← Logical right barrel shift (A, R0)	—	—	—	—	*	*	*	—	*	—
LSLW A, R0	2	*1	0	word (A) ← Logical left barrel shift (A, R0)	—	—	—	—	—	*	*	—	*	—
ASRW A, #imm8	3	*3	0	word (A) ← Arithmetic right barrel shift (A, imm8)	—	—	—	—	*	*	*	—	*	—
LSRW A, #imm8	3	*3	0	word (A) ← Logical right barrel shift (A, imm8)	—	—	—	—	*	*	*	—	*	—
LSLW A, #imm8	3	*3	0	word (A) ← Logical left barrel shift (A, imm8)	—	—	—	—	—	*	*	—	*	—
ASRL A, R0	2	*2	0	long (A) ← Arithmetic right shift (A, R0)	—	—	—	—	*	*	*	—	*	—
LSRL A, R0	2	*2	0	long (A) ← Logical right barrel shift (A, R0)	—	—	—	—	*	*	*	—	*	—
LSLL A, R0	2	*2	0	long (A) ← Logical left barrel shift (A, R0)	—	—	—	—	—	*	*	—	*	—
ASRL A, #imm8	3	*4	0	long (A) ← Arithmetic right shift (A, imm8)	—	—	—	—	*	*	*	—	*	—
LSRL A, #imm8	3	*4	0	long (A) ← Logical right barrel shift (A, imm8)	—	—	—	—	*	*	*	—	*	—
LSLL A, #imm8	3	*4	0	long (A) ← Logical left barrel shift (A, imm8)	—	—	—	—	—	*	*	—	*	—

For an explanation of “(a)” and “(b)”, refer to Table 4, “Number of Execution Cycles for Each Form of Addressing,” and Table 5, “Correction Values for Number of Cycles Used to Calculate Number of Actual Cycles.”

- \*1: 3 when R0 is 0, 3 + (R0) in all other cases.
- \*2: 3 when R0 is 0, 4 + (R0) in all other cases.
- \*3: 3 when imm8 is 0, 3 + (imm8) in all other cases.
- \*4: 3 when imm8 is 0, 4 + (imm8) in all other cases.

**Table 20 Branch 1 Instructions [31 Instructions]**

Mnemonic	#	~	B	Operation	LH	AH	I	S	T	N	Z	V	C	RMW
BZ/BEQ	rel	2	*1	0	Branch when (Z) = 1	-	-	-	-	-	-	-	-	-
BNZ/BNE	rel	2	*1	0	Branch when (Z) = 0	-	-	-	-	-	-	-	-	-
BC/BLO	rel	2	*1	0	Branch when (C) = 1	-	-	-	-	-	-	-	-	-
BNC/BHS	rel	2	*1	0	Branch when (C) = 0	-	-	-	-	-	-	-	-	-
BN	rel	2	*1	0	Branch when (N) = 1	-	-	-	-	-	-	-	-	-
BP	rel	2	*1	0	Branch when (N) = 0	-	-	-	-	-	-	-	-	-
BV	rel	2	*1	0	Branch when (V) = 1	-	-	-	-	-	-	-	-	-
BNV	rel	2	*1	0	Branch when (V) = 0	-	-	-	-	-	-	-	-	-
BT	rel	2	*1	0	Branch when (T) = 1	-	-	-	-	-	-	-	-	-
BNT	rel	2	*1	0	Branch when (T) = 0	-	-	-	-	-	-	-	-	-
BLT	rel	2	*1	0	Branch when (V) xor (N) = 1	-	-	-	-	-	-	-	-	-
BGE	rel	2	*1	0	Branch when (V) xor (N) = 0	-	-	-	-	-	-	-	-	-
BLE	rel	2	*1	0	((V) xor (N)) or (Z) = 1	-	-	-	-	-	-	-	-	-
BGT	rel	2	*1	0	((V) xor (N)) or (Z) = 0	-	-	-	-	-	-	-	-	-
BLS	rel	2	*1	0	Branch when (C) or (Z) = 1	-	-	-	-	-	-	-	-	-
BHI	rel	2	*1	0	Branch when (C) or (Z) = 0	-	-	-	-	-	-	-	-	-
BRA	rel	2	*1	0	Branch unconditionally	-	-	-	-	-	-	-	-	-
JMP	@A	1	2	0	word (PC) ← (A)	-	-	-	-	-	-	-	-	-
JMP	addr16	3	2	0	word (PC) ← addr16	-	-	-	-	-	-	-	-	-
JMP	@ear	2	3	0	word (PC) ← (ear)	-	-	-	-	-	-	-	-	-
JMP	@eam	2+	4+ (a)	(c)	word (PC) ← (eam)	-	-	-	-	-	-	-	-	-
JMPP	@ear *3	2	3	0	word (PC) ← (ear), (PCB) ← (ear+2)	-	-	-	-	-	-	-	-	-
JMPP	@eam *3	2+	4+ (a)	(d)	word (PC) ← (eam), (PCB) ← (eam+2)	-	-	-	-	-	-	-	-	-
JMPP	addr24	4	3	0	word (PC) ← ad24 0 to 15 (PCB) ← ad24 16 to 23	-	-	-	-	-	-	-	-	-
CALL	@ear *4	2	4	(c)	word (PC) ← (ear)	-	-	-	-	-	-	-	-	-
CALL	@eam *4	2+	5+ (a)	2× (c)	word (PC) ← (eam)	-	-	-	-	-	-	-	-	-
CALL	addr16 *5	3	5	(c)	word (PC) ← addr16	-	-	-	-	-	-	-	-	-
CALLV	#vct4 *5	1	5	2× (c)	Vector call linstruction	-	-	-	-	-	-	-	-	-
CALLP	@ear *6	2	7	2× (c)	word (PC) ← (ear) 0 to 15, (PCB) ← (ear) 16 to 23	-	-	-	-	-	-	-	-	-
CALLP	@eam *6	2+	8+ (a)	*2	word (PC) ← (eam) 0 to 15, (PCB) ← (eam) 16 to 23	-	-	-	-	-	-	-	-	-
CALLP	addr24 *7	4	7	2× (c)	word (PC) ← addr 0 to 15, (PCB) ← addr 16 to 23	-	-	-	-	-	-	-	-	-

For an explanation of “(a)”, “(c)” and “(d)”, refer to Table 4, “Number of Execution Cycles for Each Form of Addressing,” and Table 5, “Correction Values for Number of Cycles Used to Calculate Number of Actual Cycles.”

\*1: 3 when branching, 2 when not branching.

\*2: 3 × (c) + (b)

\*3: Read (word) branch address.

\*4: W: Save (word) to stack; R: Read (word) branch address.

\*5: Save (word) to stack.

\*6: W: Save (long word) to W stack; R: Read (long word) branch address.

\*7: Save (long word) to stack.

**Table 21 Branch 2 Instructions [20 Instructions]**

Mnemonic	#	~	B	Operation	LH	AH	I	S	T	N	Z	V	C	RMW
CBNE A, #imm8, rel	3	*1	0	Branch when byte (A) ≠ imm8	—	—	—	—	—	*	*	*	*	—
CWBNE A, #imm16, rel	4	*1	0	Branch when byte (A) ≠ imm16	—	—	—	—	—	*	*	*	*	—
CBNE ear, #imm8, rel	4	*1 *3	0	Branch when byte (ear) ≠ imm8	—	—	—	—	—	*	*	*	*	—
CBNE eam, #imm8, rel	4+	*1	(b)	Branch when byte (eam) ≠ imm8	—	—	—	—	—	*	*	*	*	—
CWBNE ear, #imm16, rel	5	*3	0	Branch when word (ear) ≠ imm16	—	—	—	—	—	*	*	*	*	—
CWBNE eam, #imm16, rel	5+	*2	(c)	Branch when word (eam) ≠ imm16	—	—	—	—	—	*	*	*	*	—
DBNZ ear, rel	3	*4	0	Branch when byte (ear) = (ear) – 1, and (ear) ≠ 0	—	—	—	—	—	*	*	*	—	—
DBNZ eam, rel	3+	*2	2× (b)	Branch when byte (ear) = (eam) – 1, and (eam) ≠ 0	—	—	—	—	—	*	*	*	—	*
DWBNZ ear, rel	3	*4	0	Branch when word (ear) = (ear) – 1, and (ear) ≠ 0	—	—	—	—	—	*	*	*	—	—
DWBNZ eam, rel	3+		2× (c)	Branch when word (eam) = (eam) – 1, and (eam) ≠ 0	—	—	—	—	—	*	*	*	—	*
INT #vct8	2	13	8× (c)	Software interrupt	—	—	R	S	—	—	—	—	—	—
INT addr16	3	14	6× (c)	Software interrupt	—	—	R	S	—	—	—	—	—	—
INTP addr24	4	9	6× (c)	Software interrupt	—	—	R	S	—	—	—	—	—	—
INT9	1	11	8× (c)	Software interrupt	—	—	R	S	—	—	—	—	—	—
RETI	1		6× (c)	Return from interrupt	—	—	*	*	*	*	*	*	*	—
RETIQ *6	2	6	*5	Return from interrupt	—	—	*	*	*	*	*	*	*	—
LINK #imm8	2		(c)	At constant entry, save old frame pointer to stack, set new frame pointer, and allocate local pointer area	—	—	—	—	—	—	—	—	—	—
UNLINK	1	5	(c)	At constant entry, retrieve old frame pointer from stack.	—	—	—	—	—	—	—	—	—	—
RET *7	1	4	(c)	Return from subroutine	—	—	—	—	—	—	—	—	—	—
RETP *8	1	5	(d)	Return from subroutine	—	—	—	—	—	—	—	—	—	—

For an explanation of “(b)”, “(c)” and “(d)”, refer to Table 5, “Correction Values for Number of Cycles Used to Calculate Number of Actual Cycles.”

- \*1: 4 when branching, 3 when not branching
- \*2: 5 when branching, 4 when not branching
- \*3: 5 + (a) when branching, 4 + (a) when not branching
- \*4: 6 + (a) when branching, 5 + (a) when not branching
- \*5: 3 × (b) + 2 × (c) when an interrupt request is generated, 6 × (c) when returning from the interrupt.
- \*6: High-speed interrupt return instruction. When an interrupt request is detected during this instruction, the instruction branches to the interrupt vector without performing stack operations when the interrupt is generated.
- \*7: Return from stack (word)
- \*8: Return from stack (long word)

**Table 22 Other Control Instructions (Byte/Word/Long Word) [36 Instructions]**

Mnemonic	#	~	B	Operation	LH	AH	I	S	T	N	Z	V	C	RMW
PUSHW A	1	3	(c)	word (SP) ← (SP) -2, ((SP)) ← (A)	-	-	-	-	-	-	-	-	-	-
PUSHW AH	1	3	(c)	word (SP) ← (SP) -2, ((SP)) ← (AH)	-	-	-	-	-	-	-	-	-	-
PUSHW PS	1	3	(c)	word (SP) ← (SP) -2, ((SP)) ← (PS)	-	-	-	-	-	-	-	-	-	-
PUSHW rlst	2	*3	*4	(SP) ← (SP) -2n, ((SP)) ← (rlst)	-	-	-	-	-	-	-	-	-	-
POPW A	1	3	(c)	word (A) ← ((SP)), (SP) ← (SP) +2	-	*	-	-	-	-	-	-	-	-
POPW AH	1	3	(c)	word (AH) ← ((SP)), (SP) ← (SP) +2	-	-	-	-	-	-	-	-	-	-
POPW PS	1	3	(c)	word (PS) ← ((SP)), (SP) ← (SP) +2	-	-	*	*	*	*	*	*	*	-
POPW rlst	2	*2	*4	(rlst) ← ((SP)), (SP) ← (SP)	-	-	-	-	-	-	-	-	-	-
JCTX @A	1	9	6× (c)	Context switch instruction	-	-	*	*	*	*	*	*	*	-
AND CCR, #imm8	2	3	0	byte (CCR) ← (CCR) and imm8	-	-	*	*	*	*	*	*	*	-
OR CCR, #imm8	2	3	0	byte (CCR) ← (CCR) or imm8	-	-	*	*	*	*	*	*	*	-
MOV RP, #imm8	2	2	0	byte (RP) ← imm8	-	-	-	-	-	-	-	-	-	-
MOV ILM, #imm8	2	2	0	byte (ILM) ← imm8	-	-	-	-	-	-	-	-	-	-
MOVEA RWi, ear	2	3	0	word (RWi) ← ear	-	-	-	-	-	-	-	-	-	-
MOVEA RWi, eam	2+	2+ (a)	0	word (RWi) ← eam	-	-	-	-	-	-	-	-	-	-
MOVEA A, ear	2	2	0	word(A) ← ear	-	*	-	-	-	-	-	-	-	-
MOVEA A, eam	2+	1+ (a)	0	word (A) ← eam	-	*	-	-	-	-	-	-	-	-
ADDSP #imm8	2	3	0	word (SP) ← ext (imm8)	-	-	-	-	-	-	-	-	-	-
ADDSP #imm16	3	3	0	word (SP) ← imm16	-	-	-	-	-	-	-	-	-	-
MOV A, brgl	2	*1	0	byte (A) ← (brgl)	Z	*	-	-	-	*	*	-	-	-
MOV brg2, A	2	1	0	byte (brg2) ← (A)	-	-	-	-	-	*	*	-	-	-
MOV brg2, #imm8	3	2	0	byte (brg2) ← imm8	-	-	-	-	-	*	*	-	-	-
NOP	1	1	0	No operation	-	-	-	-	-	-	-	-	-	-
ADB	1	1	0	Prefix code for AD space access	-	-	-	-	-	-	-	-	-	-
DTB	1	1	0	Prefix code for DT space access	-	-	-	-	-	-	-	-	-	-
PCB	1	1	0	Prefix code for PC space access	-	-	-	-	-	-	-	-	-	-
SPB	1	1	0	Prefix code for SP space access	-	-	-	-	-	-	-	-	-	-
NCC	1	1	0	Prefix code for no flag change	-	-	-	-	-	-	-	-	-	-
CMR	1	1	0	Prefix code for the common register bank	-	-	-	-	-	-	-	-	-	-
MOVW SPCU, #imm16	4	2	0	word (SPCU) ← (imm16)	-	-	-	-	-	-	-	-	-	-
MOVW SPCL, #imm16	4	2	0	word (SPCL) ← (imm16)	-	-	-	-	-	-	-	-	-	-
SETSPC	2	2	0	Stack check operation enable	-	-	-	-	-	-	-	-	-	-
CLRSPC	2	2	0	Stack check operation disable	-	-	-	-	-	-	-	-	-	-
BTSCN A	2	*5	0	byte (A) ← position of "1" bit in word (A)	Z	-	-	-	-	-	*	-	-	-
BTSCNSA	2	*6	0	byte (A) ← position of "1" bit in word (A) × 2	Z	-	-	-	-	-	*	-	-	-
BTSCNDA	2	*7	0	byte (A) ← position of "1" bit in word (A) × 4	Z	-	-	-	-	-	*	-	-	-

For an explanation of "(a)" and "(c)", refer to Tables 4 and 5.

\*1: PCB, ADB, SSB, USB, and SPB: 1 cycle

DTB: 2 cycles

DPR: 3 cycles

\*2: 3 + 4 × (pop count)

\*3: 3 + 4 × (push count)

\*4: Pop count × (c), or push count × (c)

\*5: 3 when AL is 0, 5 when AL is not 0.

\*6: 4 when AL is 0, 6 when AL is not 0.

\*7: 5 when AL is 0, 7 when AL is not 0.

**Table 23 Bit Manipulation Instructions [21 Instructions]**

Mnemonic	#	~	B	Operation	LH	AH	I	S	T	N	Z	V	C	RMW
MOVB A, dir:bp	3	3	(b)	byte (A) ← (dir:bp) b	Z	*	—	—	—	*	*	—	—	—
MOVB A, addr16:bp	4	3	(b)	byte (A) ← (addr16:bp) b	Z	*	—	—	—	*	*	—	—	—
MOVB A, io:bp	3	3	(b)	byte (A) ← (io:bp) b	Z	*	—	—	—	*	*	—	—	—
MOVB dir:bp, A	3	4	2× (b)	bit (dir:bp) b ← (A)	—	—	—	—	—	*	*	—	—	*
MOVB addr16:bp, A	4	4	2× (b)	bit (addr16:bp) b ← (A)	—	—	—	—	—	*	*	—	—	*
MOVB io:bp, A	3	4	2× (b)	bit (io:bp) b ← (A)	—	—	—	—	—	*	*	—	—	*
SETB dir:bp	3	4	2× (b)	bit (dir:bp) b ← 1	—	—	—	—	—	—	—	—	—	*
SETB addr16:bp	4	4	2× (b)	bit (addr16:bp) b ← 1	—	—	—	—	—	—	—	—	—	*
SETB io:bp	3	4	2× (b)	bit (io:bp) b ← 1	—	—	—	—	—	—	—	—	—	*
CLRB dir:bp	3	4	2× (b)	bit (dir:bp) b ← 0	—	—	—	—	—	—	—	—	—	*
CLRB addr16:bp	4	4	2× (b)	bit (addr16:bp) b ← 0	—	—	—	—	—	—	—	—	—	*
CLRB io:bp	3	4	2× (b)	bit (io:bp) b ← 0	—	—	—	—	—	—	—	—	—	*
BBC dir:bp, rel	4	*1	(b)	Branch when (dir:bp) b = 0	—	—	—	—	—	—	*	—	—	—
BBC addr16:bp, rel	5	*1	(b)	Branch when (addr16:bp) b = 0	—	—	—	—	—	—	*	—	—	—
BBC io:bp, rel	4	*1	(b)	Branch when (io:bp) b = 0	—	—	—	—	—	—	*	—	—	—
BBS dir:bp, rel	4	*1	(b)	Branch when (dir:bp) b = 1	—	—	—	—	—	—	*	—	—	—
BBS addr16:bp, rel	5	*1	(b)	Branch when (addr16:bp) b = 1	—	—	—	—	—	—	*	—	—	—
BBS io:bp, rel	4	*1	(b)	Branch when (io:bp) b = 1	—	—	—	—	—	—	*	—	—	—
SBBS addr16:bp, rel	5	*2	2× (b)	Branch when (addr16:bp) b = 1, bit = 1	—	—	—	—	—	—	*	—	—	*
WBTS io:bp	3	*3	*4	Wait until (io:bp) b = 1	—	—	—	—	—	—	—	—	—	—
WBTC io:bp	3	*3	*4	Wait until (io:bp) b = 0	—	—	—	—	—	—	—	—	—	—

For an explanation of “(b)”, refer to Table 5, “Correction Values for Number of Cycles Used to Calculate Number of Actual Cycles.”

\*1: 5 when branching, 4 when not branching

\*2: 7 when condition is satisfied, 6 when not satisfied

\*3: Undefined count

\*4: Until condition is satisfied

**Table 24 Accumulator Manipulation Instructions (Byte/Word) [6 Instructions]**

Mnemonic	#	~	B	Operation	LH	AH	I	S	T	N	Z	V	C	RMW
SWAP	1	3	0	byte (A) 0 to 7 $\leftrightarrow$ (A) 8 to 15	-	-	-	-	-	-	-	-	-	-
SWAPW	1	2	0	word (AH) $\leftrightarrow$ (AL)	-	*	-	-	-	-	-	-	-	-
EXT	1	1	0	Byte code extension	X	-	-	-	-	*	*	-	-	-
EXTW	1	2	0	Word code extension	-	X	-	-	-	*	*	-	-	-
ZEXT	1	1	0	Byte zero extension	Z	-	-	-	-	R	*	-	-	-
ZEXTW	1	2	0	Word zero extension	-	Z	-	-	-	R	*	-	-	-

**Table 25 String Instructions [10 Instructions]**

Mnemonic	#	~	B	Operation	LH	AH	I	S	T	N	Z	V	C	RMW
MOVS/MOVS	2	*2	*3	Byte transfer @AH+ $\leftarrow$ @AL+, counter = RW0	-	-	-	-	-	-	-	-	-	-
MOVSD	2	*2	*3	Byte transfer @AH- $\leftarrow$ @AL-, counter = RW0	-	-	-	-	-	-	-	-	-	-
SCEQ/SCEQI	2	*1	*4	Byte retrieval @AH+ - AL, counter = RW0	-	-	-	-	-	*	*	*	*	-
SCEQD	2	*1	*4	Byte retrieval @AH- - AL, counter = RW0	-	-	-	-	-	*	*	*	*	-
FILS/FILSI	2	5m +3	*5	Byte filling @AH+ $\leftarrow$ AL, counter = RW0	-	-	-	-	-	*	*	-	-	-
MOVSW/MOVSWI	2	*2	*6	Word transfer @AH+ $\leftarrow$ @AL+, counter = RW0	-	-	-	-	-	-	-	-	-	-
MOVSWD	2	*2	*6	Word transfer @AH- $\leftarrow$ @AL-, counter = RW0	-	-	-	-	-	-	-	-	-	-
SCWEQ/SCWEQI	2	*1	*7	Word retrieval @AH+ - AL, counter = RW0	-	-	-	-	-	*	*	*	*	-
SCWEQD	2	*1	*7	Word retrieval @AH- - AL, counter = RW0	-	-	-	-	-	*	*	*	*	-
FILSW/FILSWI	2	5m +3	*8	Word filling @AH+ $\leftarrow$ AL, counter = RW0	-	-	-	-	-	*	*	-	-	-

m: RW0 value (counter value)

\*1: 3 when RW0 is 0,  $2 + 6 \times (RW0)$  for count out, and  $6n + 4$  when match occurs

\*2: 4 when RW0 is 0,  $2 + 6 \times (RW0)$  in any other case

\*3:  $(b) \times (RW0)$

\*4:  $(b) \times n$

\*5:  $(b) \times (RW0)$

\*6:  $(c) \times (RW0)$

\*7:  $(c) \times n$

\*8:  $(c) \times (RW0)$

**Table 26 Multiple Data Transfer Instructions [18 Instructions]**

Mnemonic	#	~	B	Operation	LH	AH	I	S	T	N	Z	V	C	RMW
MOVM @A, @RLi, #imm8	3	*1	*3	Multiple data transfer byte ((A)) ← ((RLi))	—	—	—	—	—	—	—	—	—	—
MOVM @A, eam, #imm8	3+	*2	*3	Multiple data transfer byte ((A)) ← (eam)	—	—	—	—	—	—	—	—	—	—
MOVM addr16, @RLi, #imm8	5	*1	*3	Multiple data transfer byte (addr16) ← ((RLi))	—	—	—	—	—	—	—	—	—	—
MOVM addr16, eam, #imm8	5+	*2	*3	Multiple data transfer byte (addr16) ← (eam)	—	—	—	—	—	—	—	—	—	—
MOVMMW @A, @RLi, #imm8	3	*1	*4	Multiple data transfer word ((A)) ← ((RLi))	—	—	—	—	—	—	—	—	—	—
MOVMMW @A, eam, #imm8	3+	*2	*4	Multiple data transfer word ((A)) ← (eam)	—	—	—	—	—	—	—	—	—	—
MOVMMW addr16, @RLi, #imm8	5	*1	*4	Multiple data transfer word (addr16) ← ((RLi))	—	—	—	—	—	—	—	—	—	—
MOVMMW addr16, eam, #imm8	5+	*2	*4	Multiple data transfer word (addr16) ← (eam)	—	—	—	—	—	—	—	—	—	—
MOVM @RLi, @A, #imm8	3	*1	*3	Multiple data transfer byte ((RLi)) ← ((A))	—	—	—	—	—	—	—	—	—	—
MOVM eam, @A, #imm8	3+	*2	*3	Multiple data transfer byte (eam) ← ((A))	—	—	—	—	—	—	—	—	—	—
MOVM @RLi, addr16, #imm8	5	*1	*3	Multiple data transfer byte ((RLi)) ← (addr16)	—	—	—	—	—	—	—	—	—	—
MOVM eam, addr16, #imm8	5+	*2	*3	Multiple data transfer byte (eam) ← (addr16)	—	—	—	—	—	—	—	—	—	—
MOVMMW @RLi, @A, #imm8	3	*1	*4	Multiple data transfer word ((RLi)) ← ((A))	—	—	—	—	—	—	—	—	—	—
MOVMMW eam, @A, #imm8	3+	*2	*4	Multiple data transfer word (eam) ← ((A))	—	—	—	—	—	—	—	—	—	—
MOVMMW @RLi, addr16, #imm8	5	*1	*4	Multiple data transfer word ((RLi)) ← (addr16)	—	—	—	—	—	—	—	—	—	—
MOVMMW eam, addr16, #imm8	5+	*2	*4	Multiple data transfer word (eam) ← (addr16)	—	—	—	—	—	—	—	—	—	—
MOVM bnk : addr16, *5	7	*1	*3	Multiple data transfer	—	—	—	—	—	—	—	—	—	—
bnk : addr16, #imm8				byte (bnk:addr16) ← (bnk:addr16)										
MOVMMW bnk : addr16, *5	7	*1	*4	Multiple data transfer	—	—	—	—	—	—	—	—	—	—
bnk : addr16, #imm8				word (bnk:addr16) ← (bnk:addr16)										

\*1:  $5 + \text{imm8} \times 5$ , 256 times when imm8 is zero.

\*2:  $5 + \text{imm8} \times 5 + (a)$ , 256 times when imm8 is zero.

\*3: Number of transfers  $\times (b) \times 2$

\*4: Number of transfers  $\times (c) \times 2$

\*5: The bank register specified by "bnk" is the same as for the MOVS instruction.



## ■ ORDERING INFORMATION

Part number	Package	Remarks
MB90F244PFT-G	80-pin Plastic TQFP (FPT-80P-M15)	

# MB90F244

## ■ PACKAGE DIMENSIONS

80-pin Plastic TQFP  
(FPT-80P-M15)

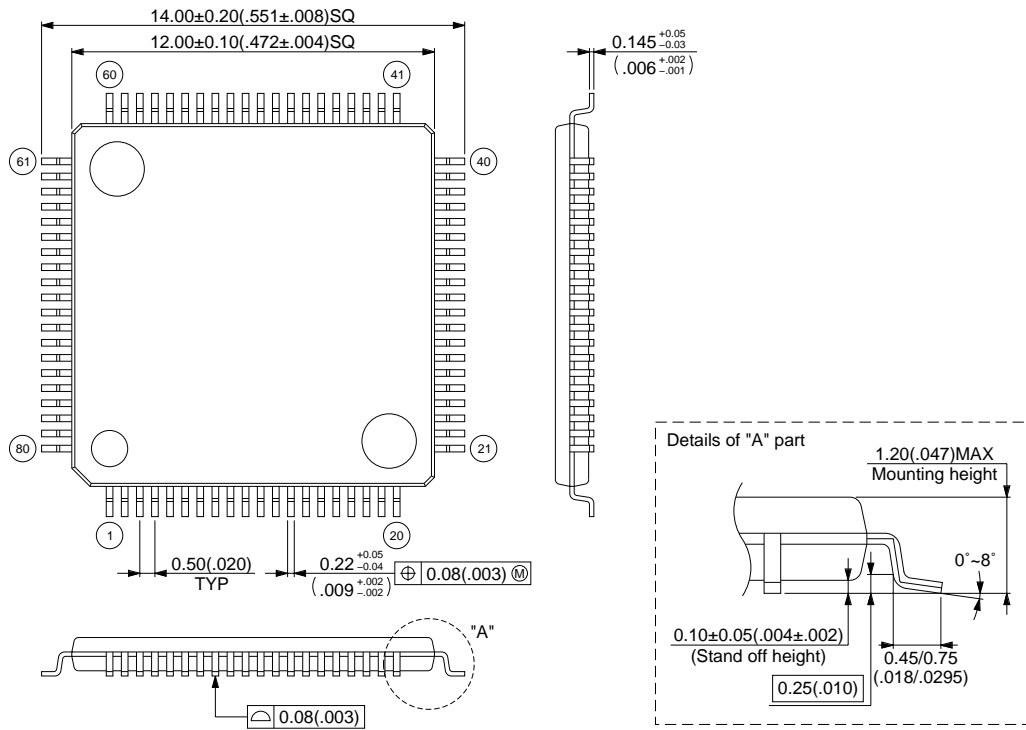

© 1997 FUJITSU LIMITED F80028S-1C-1

Dimensions in mm (inches)

## FUJITSU LIMITED

All Rights Reserved.

The contents of this document are subject to change without notice. Customers are advised to consult with FUJITSU sales representatives before ordering.

The information and circuit diagrams in this document are presented as examples of semiconductor device applications, and are not intended to be incorporated in devices for actual use. Also, FUJITSU is unable to assume responsibility for infringement of any patent rights or other rights of third parties arising from the use of this information or circuit diagrams.

The products described in this document are designed, developed and manufactured as contemplated for general use, including without limitation, ordinary industrial use, general office use, personal use, and household use, but are not designed, developed and manufactured as contemplated (1) for use accompanying fatal risks or dangers that, unless extremely high safety is secured, could have a serious effect to the public, and could lead directly to death, personal injury, severe physical damage or other loss (i.e., nuclear reaction control in nuclear facility, aircraft flight control, air traffic control, mass transport control, medical life support system, missile launch control in weapon system), or (2) for use requiring extremely high reliability (i.e., submersible repeater and artificial satellite).

Please note that Fujitsu will not be liable against you and/or any third party for any claims or damages arising in connection with above-mentioned uses of the products.

Any semiconductor devices have an inherent chance of failure. You must protect against injury, damage or loss from such failures by incorporating safety design measures into your facility and equipment such as redundancy, fire protection, and prevention of over-current levels and other abnormal operating conditions.

If any products described in this document represent goods or technologies subject to certain restrictions on export under the Foreign Exchange and Foreign Trade Law of Japan, the prior authorization by Japanese government will be required for export of those products from Japan.

F9807

© FUJITSU LIMITED Printed in Japan