

Features

- Low profile (-11mm) single board design
- 1500VDC input to output isolation meets basic insulation
- High efficiency - to 92% at full load
- Start-up into high capacitive load
- Low conducted and radiated EMI
- Output overcurrent protection
- Output overvoltage protection
- Overtemperature protection
- Remote sense
- Set point accuracy $\pm 1\%$
- Remote on/off (primary referenced), positive or negative logic
- Output voltage trim adjust, positive or negative
- UL 1950 Recognized, CSA 22.2 No. 950-95 certified, TUV IEC950

Applications

- Distributed power architectures
- Telecommunications equipment
- LAN/WAN applications
- Data processing applications

Description

The new HLS30 series of high-density, single-output DC/DC converters, convert standard telecom and datacom voltages into isolated low voltage outputs. High efficiencies and a patent-pending board design create superior thermal transfer that enhances product reliability and eliminates the need for a heatsink.

Selection Chart

Model	Input voltage VDC	Input current, max ADC	Output voltage VDC	Output rated current I_{rated} ADC	Output Ripple/Noise, mV p-p	Typical Efficiency @ I_{rated} %
HLS30ZG	36-75	4.8	5.0	30	100	91
HLS30ZE	36-75	3.3	3.3	30	75	89
HLS30ZD	36-75	2.5	2.5	30	50	88

This product is intended for integration into end-use equipment. All the required procedures for CE marking of end-use equipment should be followed.



HLS30 Series – 30A Half-Brick DC/DC Converter
48V Input
5.0V, 3.3V, 2.5V Output

Data Sheet

Absolute Maximum Ratings

Stresses in excess of the absolute maximum ratings may cause performance degradation, adversely effect long-term reliability and cause permanent damage to the converter.

Parameter	Conditions/Description	Min	Max	Units
Input voltage	Continuous		75	VDC
	Transient, 100mS		100	VDC
Operating Temperature	At 100% load	-40	100	°C
Storage Temperature		-40	125	°C
ON/OFF Control Voltage	Referenced to -Vin		50	VDC

Environmental and Mechanical Specifications

All specifications apply over specified input voltage, output load and temperature range, unless otherwise noted.

Parameter	Conditions/Description	Min	Nom	Max	Units
Shock	Halfsine wave, 3 axes	50			g
Sinusoidal Vibration	GR-63-Core, Section 5.A.2	1			
Weight			1.6/46		Oz/g
Water Washing	Standard process		Yes		
MTBF	Per Bellcore TR-NWT-000332		1,780		kHrs

Isolation Specifications

All specifications apply over specified input voltage, output load and temperature range, unless otherwise noted.

Parameter	Conditions/Description	Min	Nom	Max	Units
Insulation Safety Rating		Basic			
Isolation Voltage		1500			VDC
Isolation Resistance		10			MOhm
Isolation Capacitance		1100			pF

Input Specifications

All specifications apply over specified input voltage, output load and temperature range, unless otherwise noted.

Parameter	Conditions/Description	Min	Nom	Max	Units
Input Voltage	Continuous	36	48	75	VDC
Turn-On Input Voltage	Ramping Up		33		VDC
Turn-Off Input Voltage	Ramping Down		32		VDC
Turn-On Time	To Output Regulation Band 100% Resistive Load		5		mS
Input Reflected Ripple Current	Full Load, 12uH source inductance			80	mA p-p
Inrush Transient	Vin=Vin.max		0.1		A ² s

Output Specifications

All specifications apply over specified input voltage, output load and temperature range, unless otherwise noted.

Parameter	Conditions/Description	Min	Nom	Max	Units
Output Voltage Setpoint Accuracy	Vin=Vin.nom, Full Load	-1		1	%Vout
Output Current*		3		30	ADC
Line Regulation	Vin.min to Vin.max, Iout.max			0.2	%Vout
Load Regulation	Vin=Vnom, Iout.min to Iout.max			0.2	%Vout
Total output voltage regulation	Over all input voltage, load, and temperature conditions	-2		2	%Vout
Remote Sense Headroom				0.5	VDC
Dynamic Regulation Peak Deviation Settling Time	50-75% load step change to 1% error band			8 150	%Vout μS
Admissible Load Capacitance	Iout.max, Nom Vin	30,000			μF
Output Current Limit Threshold**	Vout≤0.97Vout.nom	110		140	%Iout
Switching Frequency			270		kHz
Overvoltage Protection, Non Latching	Over all input voltage and load conditions	120		140	%Vout
Trim Range	Iout.max, Vin=Vnom	90		110	%Vout

* At Iout<Iout.min, the output may contain low frequency component that exceeds ripple specifications.

** Overcurrent protection is non-latching with auto recovery.

Feature Specifications

All specifications apply over specified input voltage, output load and temperature range, unless otherwise noted.

Parameter	Conditions/Description	Min	Nom	Max	Units
Shutdown (ON/OFF) Negative Logic - Converter ON - Source Current - Converter OFF	On/Off signal is low – converter is ON ON/OFF pin is connected to -Vin	-1.0	0.85	1.8	VDC mADC VDC
-Open Circuit Voltage	ON/OFF pin is floating	3.5	2	50	VDC
Positive Logic - Converter ON - Open Circuit Voltage - Converter OFF - Source Current	On/Off signal is low –converter is OFF ON/OFF pin is floating ON/OFF pin is connected to -Vin	3.5 -1.0	3	50 1.8 0.46	VDC VDC VDC mADC
Overtemperature Protection	Average PCB Temp. – Shut down - Recover		90		°C

Characteristic curves

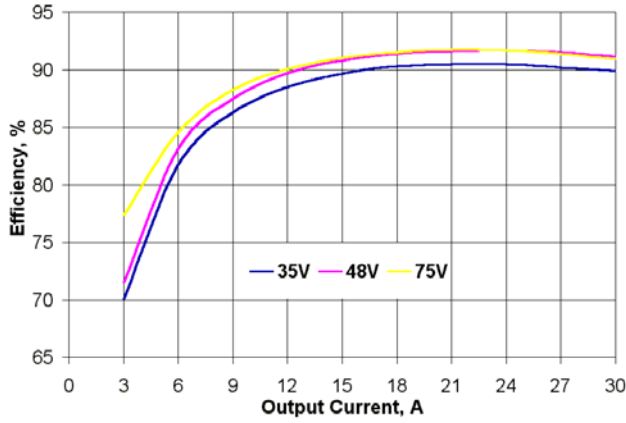

Fig. 1 HLS30ZG (5V) Efficiency vs. Output Load

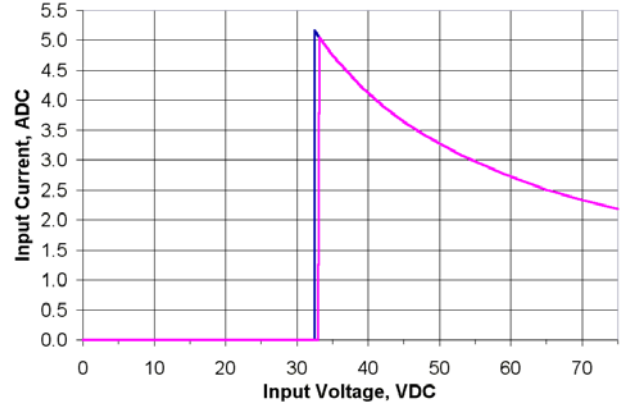

Fig. 4 HLS30ZG (5V) Input Characteristic

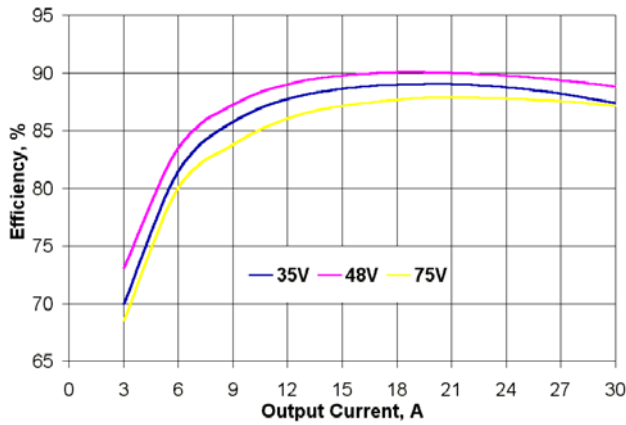

Fig. 2 HLS30ZE (3.3V) Efficiency vs. Output Load

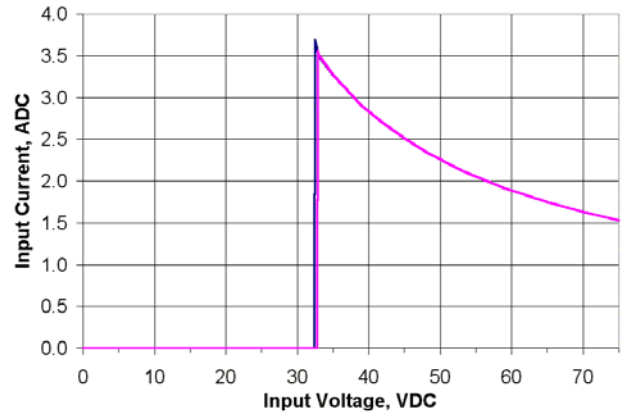

Fig. 5 HLS30ZE (3.3V) Input Characteristic

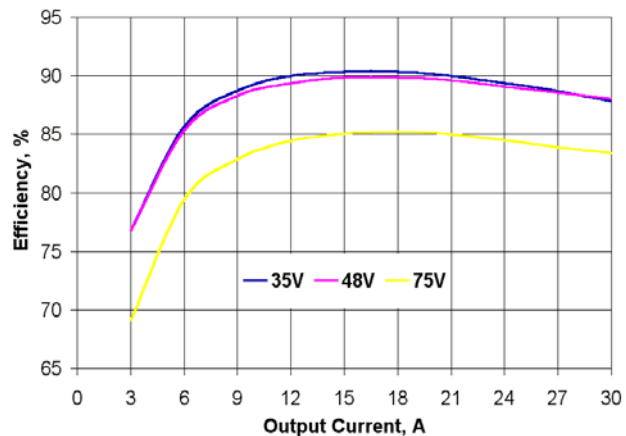

Fig. 3 HLS30ZD (2.5V) Efficiency vs. Output Load

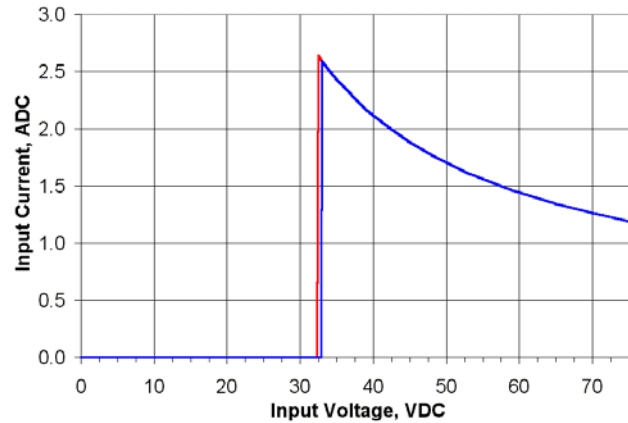

Fig. 6 HLS030ZD (2.5V) Input Characteristic

Typical Application

Figure 7 below shows the recommended connections for the HLS30 series converter.

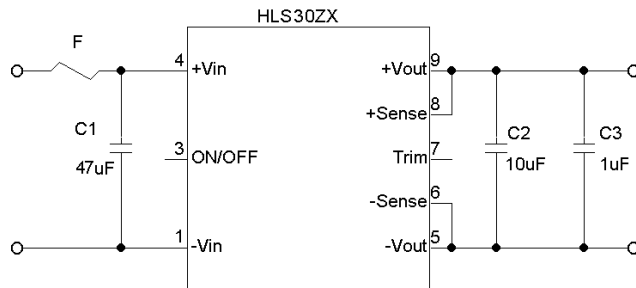

Fig.7 Typical application of HLS30 series

The HLS30 series converters do not require any external components for proper operation. However, if the distribution of the input voltage to the converter contains significant inductance, the capacitor C1 may be required to enhance performance of the converter. A minimum of a 47µF electrolytic capacitor with the ESR<0.7Ω is recommended for the HLS30 series.

If magnitude of the inrush current needs to be limited, see the “Inrush Current Control Application Note” on Power-One website www.power-one.com.

For output decoupling we recommend to use a 10µF tantalum and a 1µF ceramic capacitors connected directly across the output pins of the converter. Note, that the capacitors do not substitute the filtering required by the load.

Shutdown Feature Description

The ON/OFF pin in the HLS30 series converters functions as a normal soft shutdown. It is referenced to the –Vin pin (see Figure 7). With positive logic, when the ON/OFF pin is pulled low, the output is turned off and the unit goes into a very low input power mode. With negative logic, when the ON/OFF pin is pulled low, the unit is turned on.

An open collector switch is recommended to control the voltage between the ON/OFF pin and the –Vin pin of the converter. The ON/OFF pin is pulled up internally, so no external voltage source is required. The user should avoid connecting a

resistor between the ON/OFF pin and the +Vin pin.

When the ON/OFF pin is used to achieve remote control, the user must take care to insure that the pin reference for the control is really the –Vin pin. The control signal must not be referenced ahead of EMI filtering or remotely from the unit. Optically coupling the information and locating the optical coupler directly at the module will solve any of these problems.

Note:

If the ON/OFF pin is not used, it can be left floating (positive logic), or connected to the –Vin pin (negative logic).

Output Voltage Trim

The trim feature allows the user to adjust the output voltage from the nominal value. This can be used to compensate distribution drops, perform margining in production, or accommodate other requirements when output voltage needs to be adjusted from the nominal. There are two trim options available in the HLS30 series.

Standard Negative Trim (No suffix)

The negative trim method is the Power-One standard. The HLS30 standard trim units trim up with a resistor from the TRIM pin to the Sense pin and trim down with a resistor from the TRIM pin to the +Sense pin as shown in Figure 8.

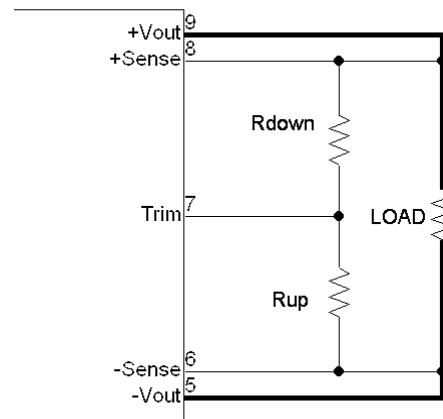

Fig. 8 HLS30 series negative trim schematic

The general equation (1) for changing the output voltage on the standard trim modules is invariant, but the constants in the equation change due to different internal design.

$$R_{TRIM} = \frac{A - B \times \Delta V}{\Delta V}, \text{ KOhm} \quad (1)$$

where A and B are constants from the table below, and ΔV is the absolute value of the desired change in the output voltage in Volts.

Model	Trim up		Trim down	
	A	B	A	B
HLS30ZG	3.77	6.81	11.58	9.88
HLS30ZE	2.07	3.92	3.5	5.61
HLS30ZD	1.27	3.92	1.31	4.95

Optional Positive Trim (suffix -T)

The -T option units trim up with a resistor from the TRIM pin to the +Sense pin and trim down with a resistor from the TRIM pin to the -Sense pin as shown in the Figure 9.

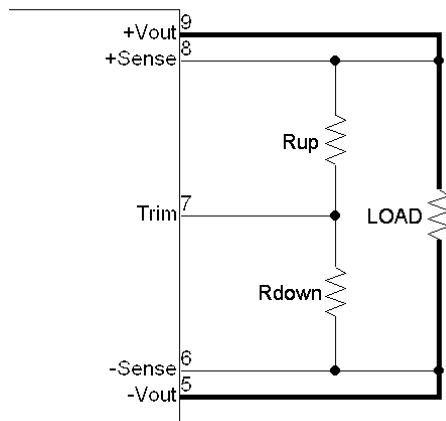

Fig.9 HLS30 series positive trim schematic

The equations below determine the trim resistor value required to achieve a ΔV change in the output voltage.

$$R_{UP} = \frac{V_{out} \times (100 + \Delta V\%) - 100 + 2 \times \Delta V\%}{1.225 \times \Delta V\% - \Delta V\%}, \text{ kOhm}$$

$$R_{DOWN} = \frac{100}{\Delta V\%} - 2, \text{ kOhm}$$

where $\Delta V\%$ is the output voltage change expressed in percents of the nominal output voltage, V_{out} .

Notes:

1. When the output voltage is trimmed up, the output power from the converter must not exceed its maximum rating. This is determined by measuring the output voltage on the output pins, and multiplying it by the output current.
2. In order to avoid creating apparent load regulation degradation, it is important that the trim resistors are connected directly to the remote sense pins, and not to the load or to traces going to the load.
3. The HLS30 series converters will trim down further than the 10% limit. In general, this is permissible. The user must confirm that the results are acceptable in his application.

Safety Considerations

The HLS30 series converters feature 1500 Volt DC isolation from input to output. The input to output DC resistance is greater than 10MOhm. These converters are provided with Basic insulation between input and output circuits according to all IEC60950 based standards. Nevertheless, if the system using the converter needs to receive safety agency approval, certain rules must be followed in the design of the system. In particular, all of the creepage and clearance requirements of the end-use safety requirements must be observed. These documents include UL60950, CSA60950-00 and EN60950, although other additional requirements may be needed for user's specific applications.

The HLS30 series converters have no internal fuse. An external fuse must be provided to protect the system from catastrophic failure, as illustrated in Figure 7. The fuse with a rating not greater than 10A is recommended. The user can select a lower rating fuse based upon the highest inrush transient at the maximum input voltage and the maximum input current of the converter at the minimum input voltage. Both input traces and the chassis ground trace (if applicable) must be capable of conducting a current of 1.5 times the

HLS30 Series – 30A Half-Brick DC/DC Converter
48V Input
5.0V, 3.3V, 2.5V Output

value of the fuse without opening. The fuse must not be placed in the grounded input line, if any.

In order for the output of the HLS30 series converter to be considered as SELV (Safety Extra Low Voltage) or TNV-1, according to all IEC60950 based standards, one of the following requirements must be met in the system design:

- If the voltage source feeding the module is SELV or TNV-2, the output of the converter may be grounded or ungrounded.
- If the voltage source feeding the module is ELV, the output of the converter may be considered SELV only if the output is grounded per the requirements of the standard.
- If the voltage source feeding the module is a Hazardous Voltage Secondary Circuit, the voltage source feeding the module must be provided with at least Basic insulation between the source to the converter and any hazardous voltages. The entire system, including the HLS30 converter, must pass a dielectric withstand test for Reinforced insulation. Design of this type of systems requires expert engineering and understanding of the overall safety requirements and should be performed by qualified personnel.

Thermal Considerations

The HLS30 series converters are designed for natural or forced convection cooling. The maximum allowable output power of the converters is determined by meeting the derating criteria of all electronic components used in the power supplies. An example of the derating criteria for the semiconductor junction temperature is not to exceed 120C to provide reliable long-term operation of the converters. Note: Please contact Power-One for more derating criteria for other components.

The graphs in Figures 10-12 show the maximum output current of the HLS30 series converters at different ambient temperatures under both natural and forced (longitudinal airflow direction, from pin 1 to pin 4) convection. As an example, from Figure 10, the HLS30ZG operating at 55C can deliver up to 25.5A reliably with 100LFM forced

air, while up to 28A reliably with 200LFM forced air.

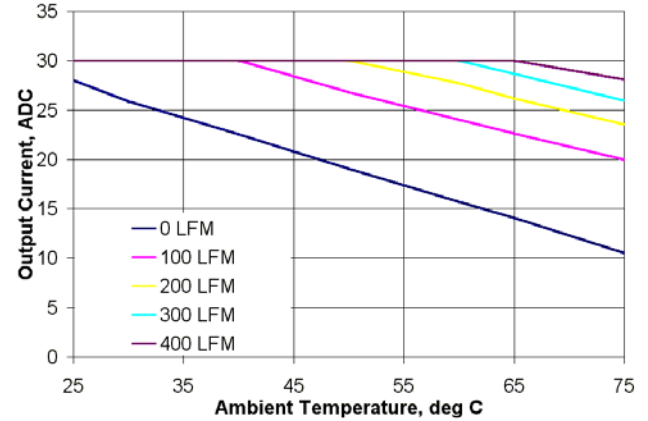

Fig.10 HLS30ZG (5V) derating curves

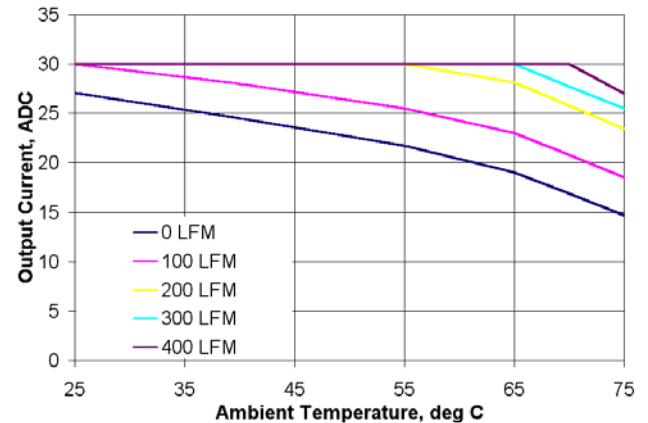

Fig.11 HLS30ZE (3.3V) derating curves

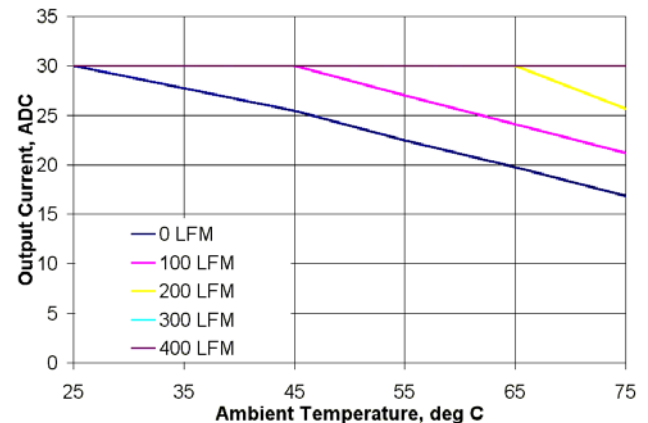
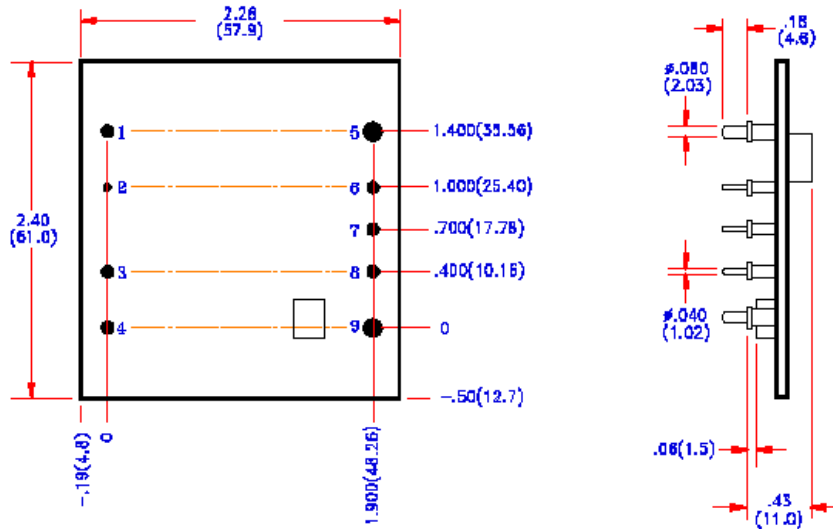

Fig.12 HLS30ZD (2.5V) derating curves

Mechanical Drawing



PIN	FUNCTION
1	-Vin
2	No Pin
3	On/Off
4	+Vin
5	-Vout
6	-Sense
7	Trim
8	+Sense
9	+Vout

Tolerances: .xx ± .020 (.5)
 .xxx ± .010 (.25)
 Pin Diameter ± 0.002 (.05)

Ordering Information

Options	Suffixes to add to part number
Remote ON/OFF	Positive- no suffix required
	Negative- Add "N" suffix
Trim	Negative- no suffix required
	Positive - Add "T" suffix
Pin Length	0.18"- no suffix required
	0.11"- Add "8" suffix
	0.15"- Add "9" suffix

Notes

1. Consult factory for the complete list of available options.
2. Power-One products are not authorized for use as critical components in life support systems, equipment used in hazardous environments, or nuclear control systems without the express written consent of the President of Power-One, Inc.
3. Specifications are subject to change without notice.