

FEATURES

- handles high input levels (up to 100 mVRMS) cleanly
- low THD and IMD distortion
- unique twin average detectors
- dual channel signal processing
- adjustable AGC threshold levels
- highpass filter with adjustable corner frequency
- 2:1 compression of high frequencies
- no external capacitors or resistors required
- 30% smaller by volume than DynamEQ® I GS3011

DESCRIPTION

The DynamEQ® I hybrid is a dynamically adaptive loudness growth equalizer. Its gain and frequency response is dependent on the user's environment, and is designed for level dependant frequency response providing treble increase at low levels (TILL). The unique twin averaging detector circuit dramatically reduces pumping effects and is optimized for mild to moderate hearing loss.

DynamEQ® I has two signal paths for dual channel processing incorporating 4 amplifying stages (A, B, C, D) and the AGC processing circuit.

Stage A is a highpass channel with 2:1 compression, Stage B is a wideband unity gain buffer. The sum of the two paths gives a high frequency boost to low level signals, which gradually compresses to a flat response at high input levels. Stage C is used for volume control adjustment, while stage D is a class A power amplifier with receiver bias current adjustment.

STANDARD PACKAGING

- Hybrid Typical Dimensions
0.250 in x 0.115 in x 0.115 in
(6.35 mm x 2.92 mm x 2.92 mm)

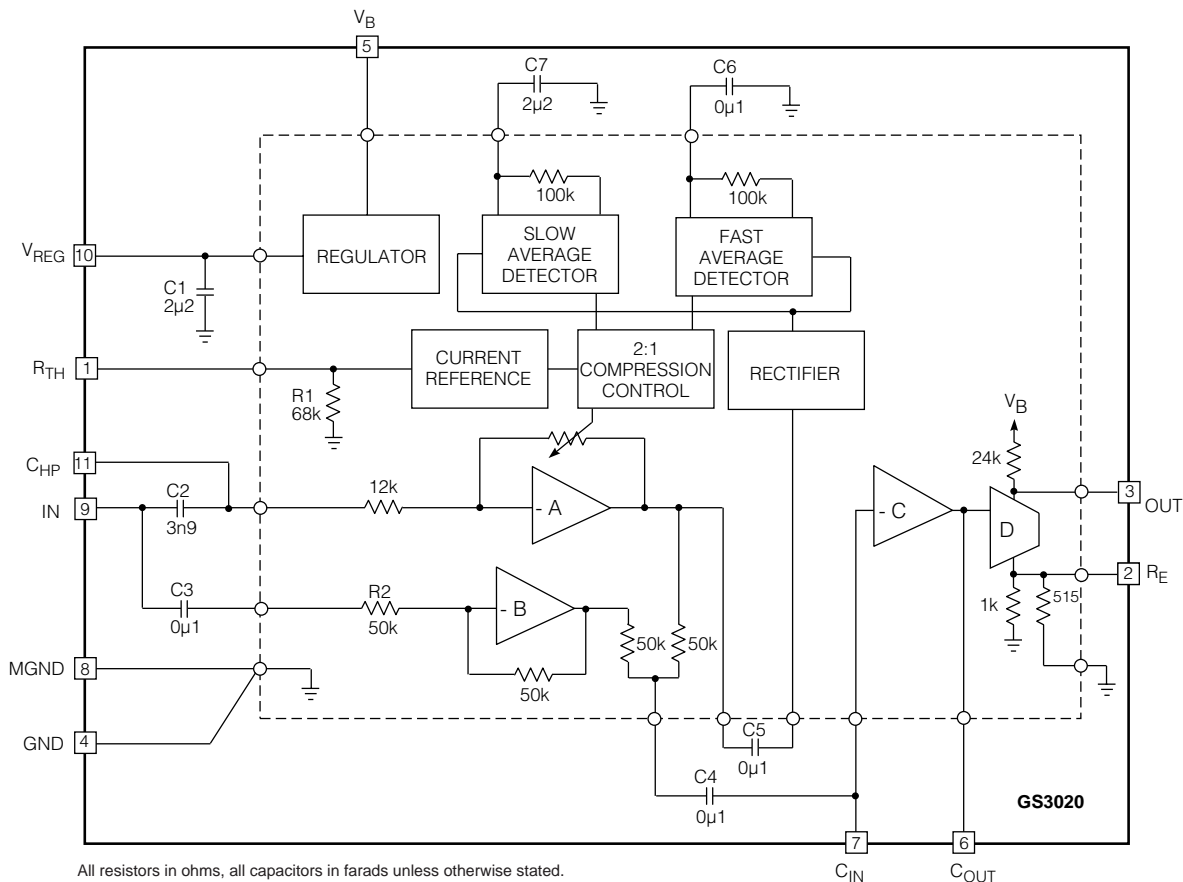

All resistors in ohms, all capacitors in farads unless otherwise stated.
Patent Pending.

FUNCTIONAL BLOCK DIAGRAM

ABSOLUTE MAXIMUM RATINGS

PARAMETER	VALUE / UNITS
Supply Voltage	3 VDC
Power Dissipation	25 mW
Operating Temperature Range	-10° C to 40° C
Storage Temperature Range	-20° C to 70° C

CAUTION
CLASS 1 ESD SENSITIVITY



PAD CONNECTION

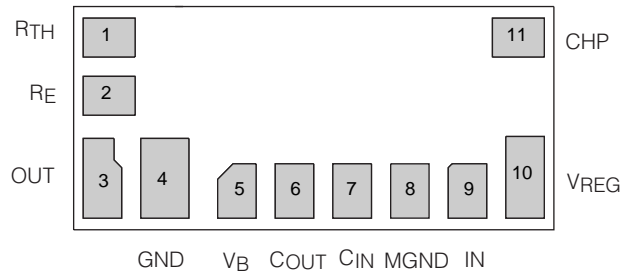

ELECTRICAL CHARACTERISTICS

Conditions: Input Level $V_{IN} = -97$ dBV, Frequency = 5 kHz, Temperature = 25°C, Supply Voltage $V_B = 1.3$ V

PARAMETER	SYMBOL	CONDITIONS	MIN	TYP	MAX	UNITS
Hybrid Current	I_{AMP}	$V_{IN} = 0V_{RMS}$	90	190	300	μA
Minimum Voltage	V_B		1.1	-	-	V
Total Harmonic Distortion	THD	$R_{VC} = 15k\Omega$; $V_{IN} = -40dBV$ at 1kHz	-	0.1	1	%
Input Referred Noise	IRN	NFB 0.2 to 10kHz at 12dB/oct	-	2.5	-	$\mu VRMS$
Total System Gain	A_V		52.5	55.5	58.5	dB
AGC						
Compression Ratio	COMP	$V_{IN} = -60dBV$ & $-80dBV$, $R_{VC} = 15k$	1.74:1	1.95:1	2.11:1	Ratio
Threshold			-	-94	-	dBV
Compression Gain Range	A_{RANGE}	$R_{VC} = 15k\Omega$; Note 1	26	28	-	dB
High Pass Corner Frequency	f_{HPC}	C_{HP} - Not Connected	-	3.4	-	kHz
System Gain in Compression	A_{80}	$V_{IN} = -80dBV$	45	47	49	dB
OUTPUT STAGE						
Minimum Transducer Current	I_{TR}	R_E - Not Connected	130	160	190	μA
Maximum Current Sink	I_{SINK}		3	6	-	mA
Output Impedance	Z_{OUT}		20	24	28	$k\Omega$
R_E Voltage	V_{RE}		52	56	60	mV
REGULATOR						
Regulator Voltage	V_{REG}		0.89	0.95	0.99	V

All parameters and switches remain as shown in the Test Circuit unless otherwise stated in CONDITIONS column

V_{PX} actual voltage measured on the pin at given condition (X is pin number)

Notes: 1. $A_{RANGE} = V_{P3} [V_{IN} = -97dBV] - V_{P3} [V_{IN} = -20 dBV] + 77dBV$

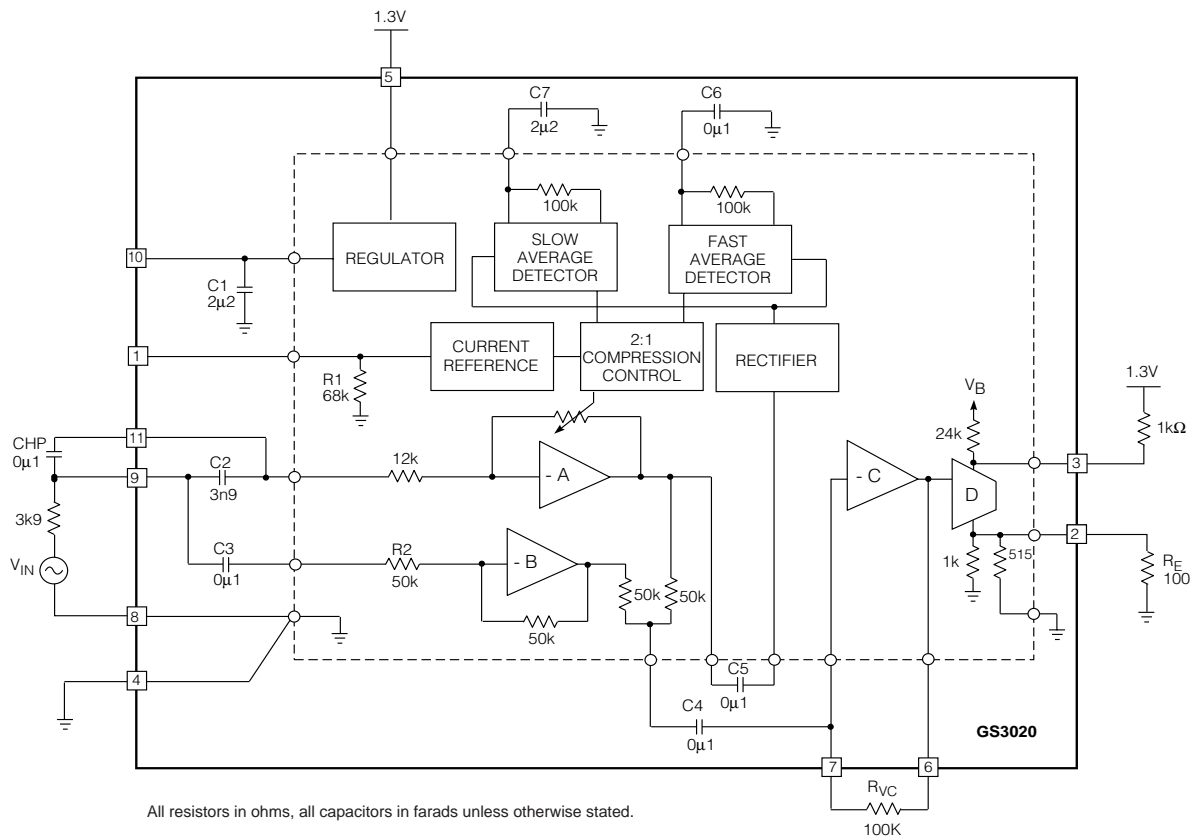

Fig. 1 Production Test Circuit

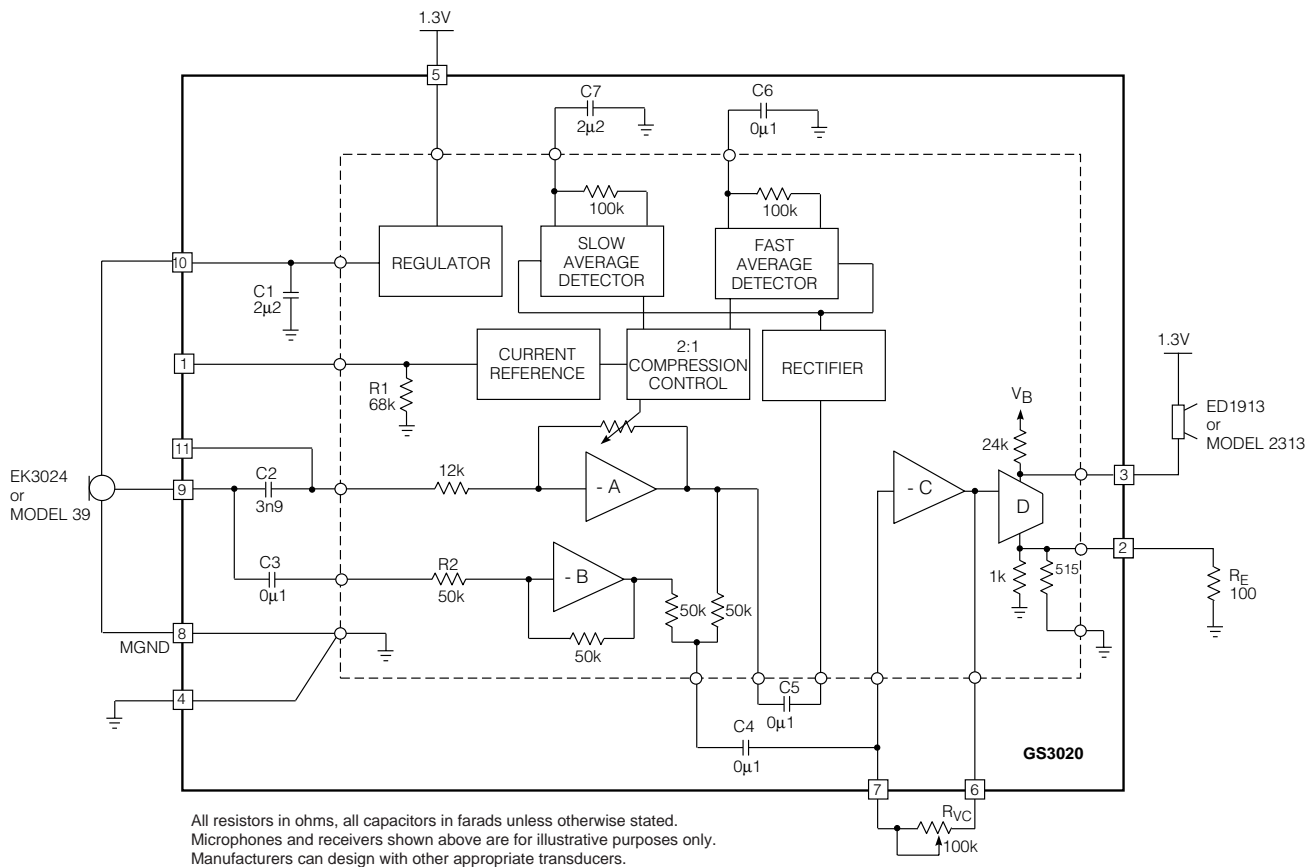

Fig. 2 Example of Hearing Instrument Application

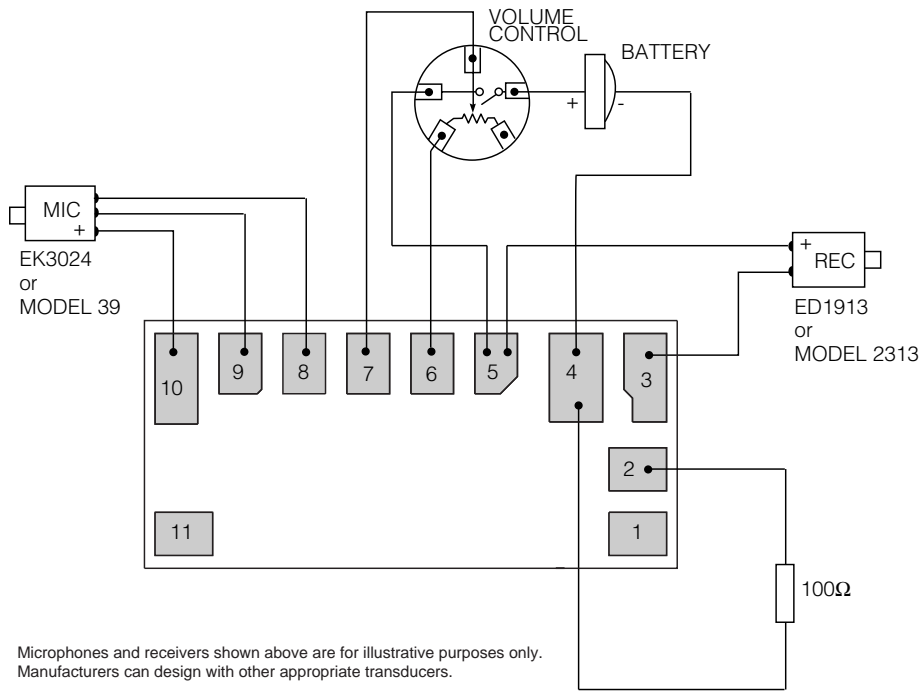

Fig. 3 Example of Assembly Diagram

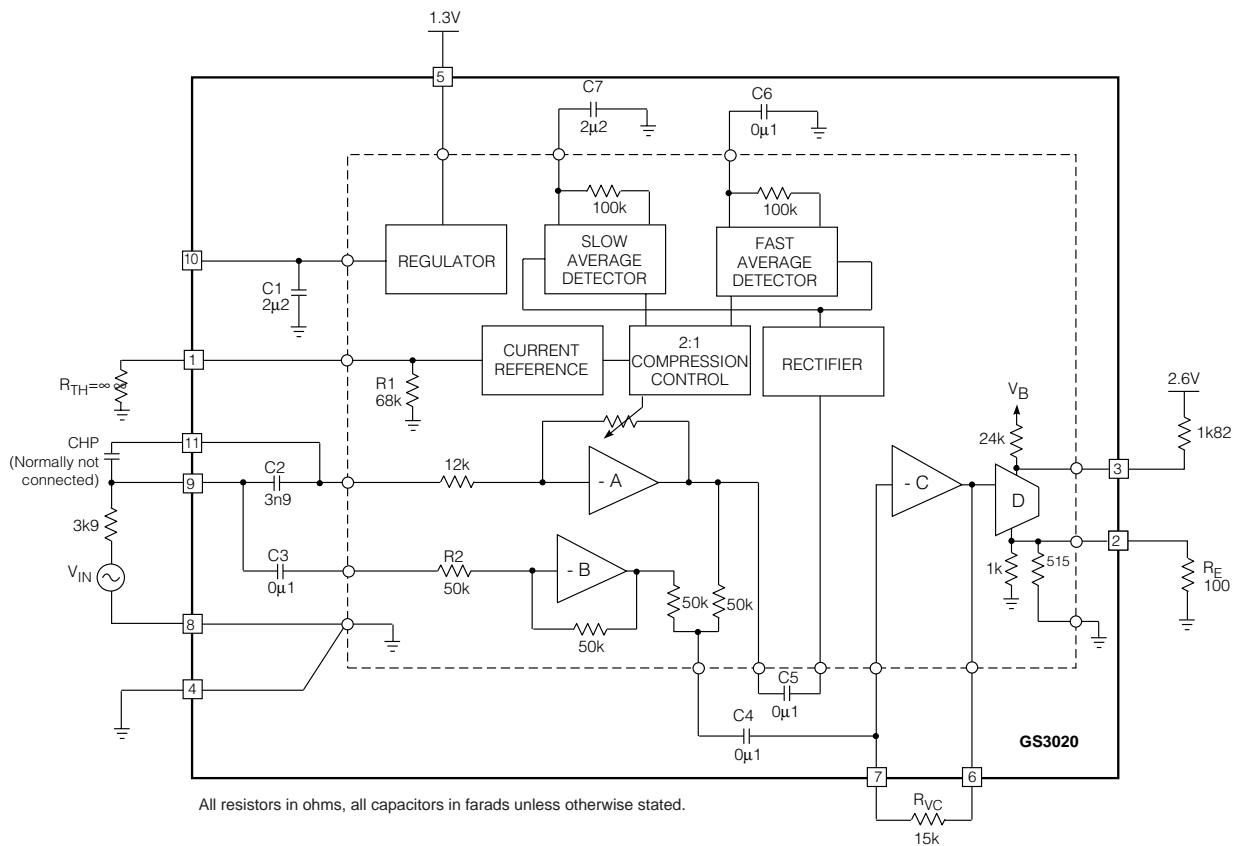

Fig. 4 Characterization Circuit (used to generate typical curves)

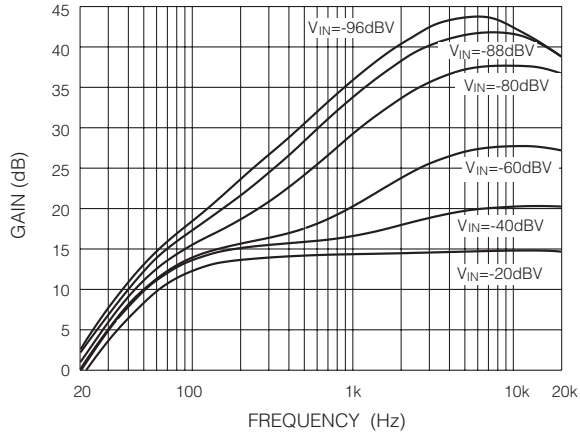

Fig. 5 Frequency Response for Different Input Levels

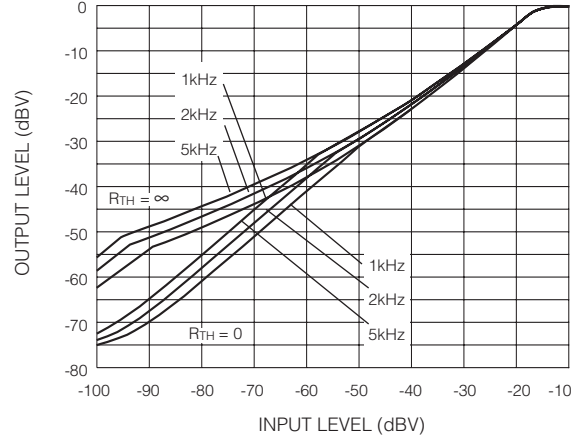

Fig. 6 I/O Transfer Function for Different Test Frequencies. Shown for Min/Max R_{TH} Resistors Values

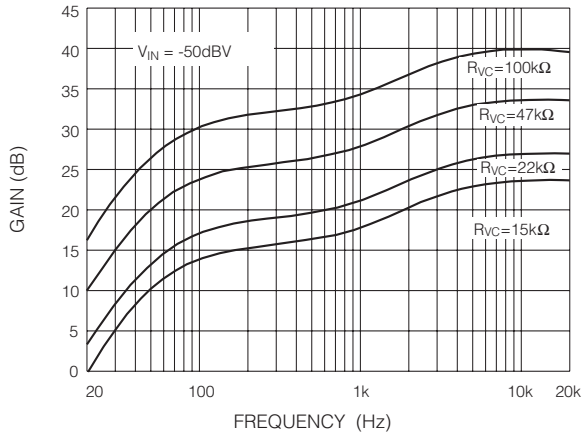

Fig. 7 Frequency Response for Different R_{VC} Values

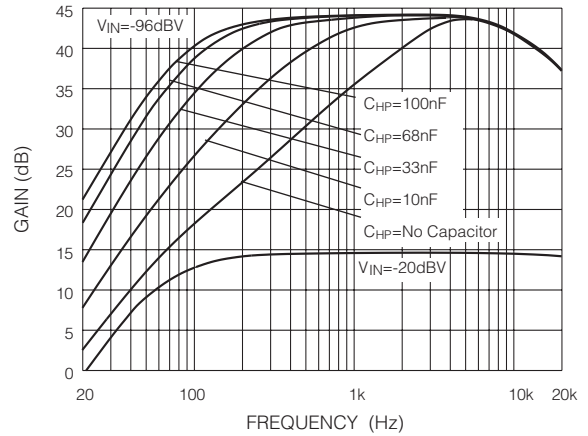

Fig. 8 Corner Frequency vs C_{HP} Capacitor Value

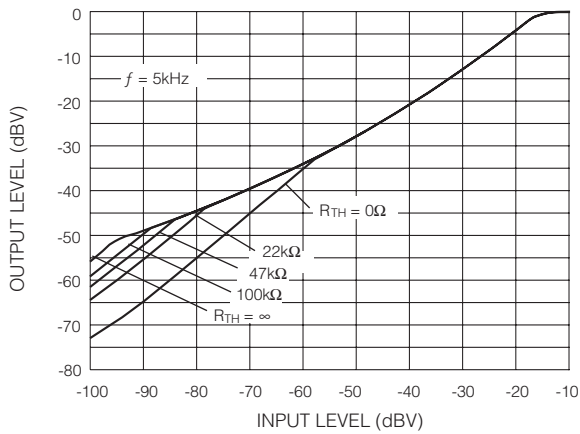

Fig. 9 I/O Transfer Function for Different R_{TH} Resistors

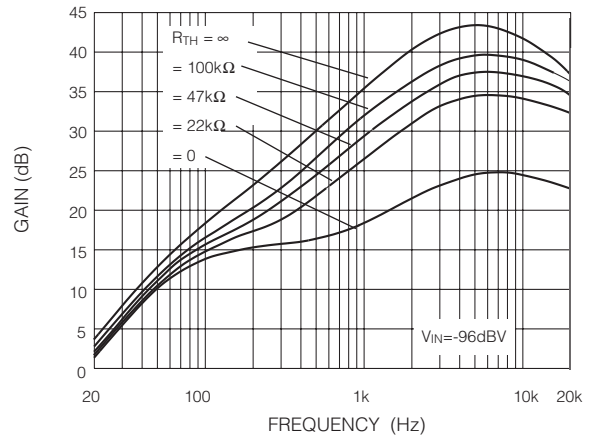

Fig. 10 Frequency Characteristics for Different R_{TH} Values

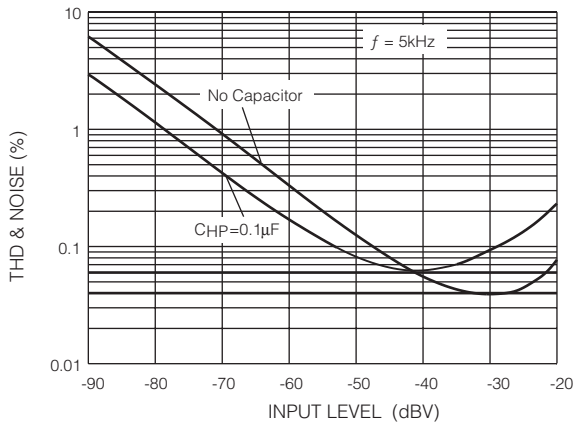

Fig. 11 THD & Noise vs Input Level

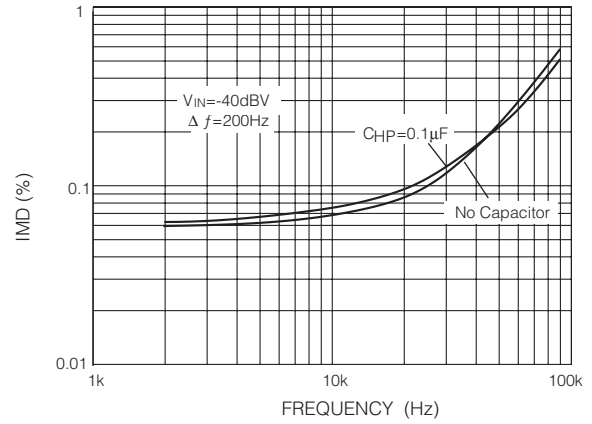
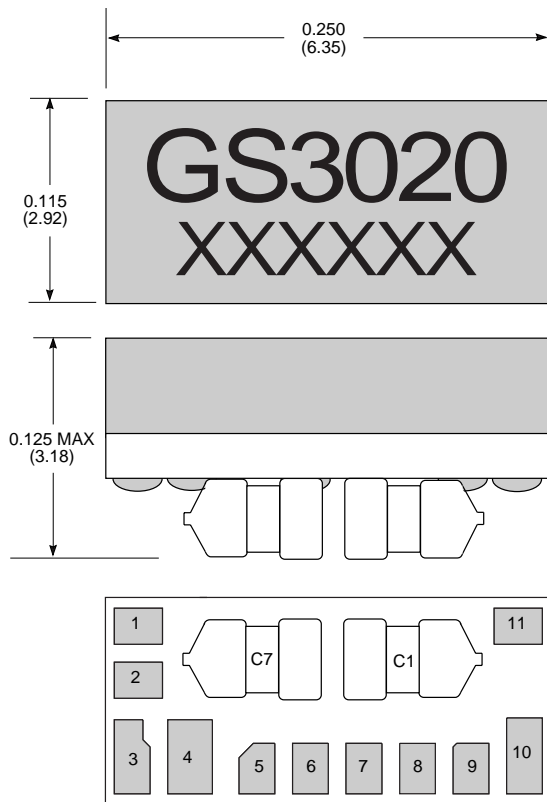

Fig. 12 Intermodulation Distortion (CCIF) vs Frequency



Dimension units are in inches.
 Dimensions in parenthesis are in millimetres converted from inches and include minor rounding errors.
 1.0000 inches = 25.400 mm.
 Dimension $\pm 0.005 (+0.13)$ unless otherwise stated.
 Pad numbers for illustration purposes only.
 Smallest pad 0.020 x 0.027 (0.51 x 0.69)
 Largest pad 0.025 x 0.041 (0.64 x 1.04)
 XXXXXX - work order number.
 This hybrid is designed for point to point manual soldering.

Fig. 13 Hybrid Layout & Dimensions

DOCUMENT IDENTIFICATION: DATA SHEET
 The product is in production. Gennum reserves the right to make changes at any time to improve reliability, function or design, in order to provide the best product possible.

REVISION NOTES:
 Updated to Data sheet

This datasheet has been download from:

www.datasheetcatalog.com

Datasheets for electronics components.