

■ Features

- High Efficiency: **84%** Typical
- 36V High Output Voltage
- Fast **1MHz** Switching Frequency
- Low Profile SOT23-5 **Pb-Free** Packaging

■ Applications

- Cellular Phones
- PDAs, Handhelp Computers
- Digital Cameras
- LCD Bias Voltage, Battery Backup
-

■ Pin Assignments

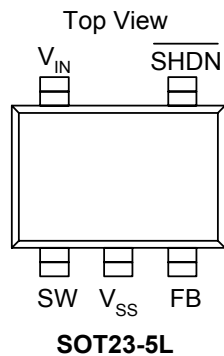

■ General Description

The AP1522 is a step-up DC/DC converter in a 5-Lead low profile SOT23-5 package. The AP1522 switches at 1MHz that allows the use of tiny external components. A low 1.25V feedback voltage minimizes power loss in the current setting resistor for better efficiency.

■ Pin Descriptions

Name	Description
SW	Switch Pin. Connect inductor/diode here. Minimize trace area at this pin to reduce EMI.
V _{SS}	GND pin
FB	Feedback Pin. Reference voltage is 1.25V.
SHDN	Shutdown Pin. Tie to 0.6V or higher to enable device ; 0.5V or less to disable device.
V _{IN}	Input Supply Pin. Must be locally bypassed.

■ Ordering Information

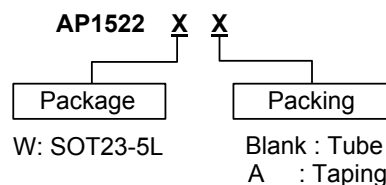

■ Block Diagram

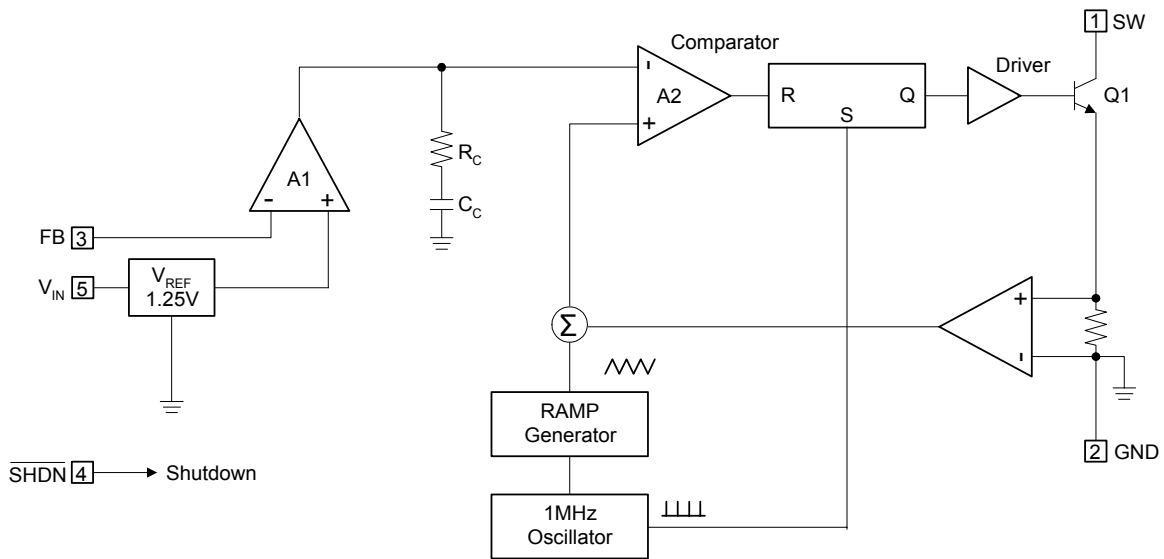

■ Absolute Maximum Ratings

Symbol	Parameter	Rating	Unit
V_{IN}	V_{IN} Pin Voltage	10	V
V_{SW}	SW Voltage	36	V
V_{FB}	Feedback Pin Voltage	10	V
V_{SHDN}	SHDN Pin Voltage	10	V
T_J	Maximum Junction Temperature	125	°C
T_{LEAD}	Power Dissipation	300	°C
T_{OPR}	Operating Temperature Range	-40 to +85	°C
T_{STG}	Storage Temperature Range	-40 to +125	°C

Caution The absolute maximum ratings are rated values exceeding which the product could suffer physical damage. These values must therefore not be exceeded under any conditions.

Step-Up DC/DC Converter

■ Electrical Characteristics ($T_a=25^\circ\text{C}$, $V_{IN} = 5\text{V}$, $V_{SHDN} = 5\text{V}$, unless otherwise noted.)

Symbol	Parameter	Conditions	Min.	Typ.	Max.	Unit
V_{IN}	Minimum Operation Voltage	-	2.5	-	-	V
V_{IN}	Maximum Operation Voltage	-	-	-	10	V
V_{FB}	Feedback Pin Voltage	-	1.225	1.25	1.275	V
I_{FB}	Feedback Pin Bios Current	-	10	45	100	nA
	Supply Current	Operation current	-	2	3	mA
		$V_{SHDN} = 0\text{V}$	-	0.1	1.0	μA
F_{SW}	Switching frequency		0.75	1.0	1.25	MHz
Duty	PWM Maximum Duty Cycle		85	90	-	%
I_{SW}	Switch Current Limit		280	320	360	mA
V_{SAT}	Switch V_{SAT}	$I_{SW} = 250\text{mA}$	-	350	-	mV
	Switch Leakage Current	$V_{SW} = 5\text{V}$	-	0.1	5	μA
V_{SHDN}	SHDN Pin Voltage High	Enable	0.6	-	-	V
V_{SHDN}	SHDN Pin Voltage Low	Disable	-	-	0.5	V
I_{SHDN}	SHDN Pin Bios Current		-	10	-	μA

■ Typical Application Circuit

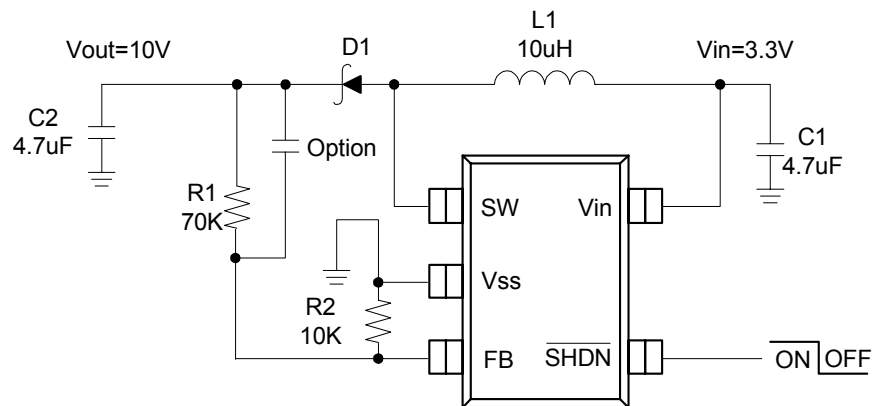

$$V_{OUT} = V_{FB} \left(1 + \frac{R1}{R2} \right)$$

$$1\text{K} \leq R2 \leq 50\text{K}$$

■ Typical Application Circuit (Continued)

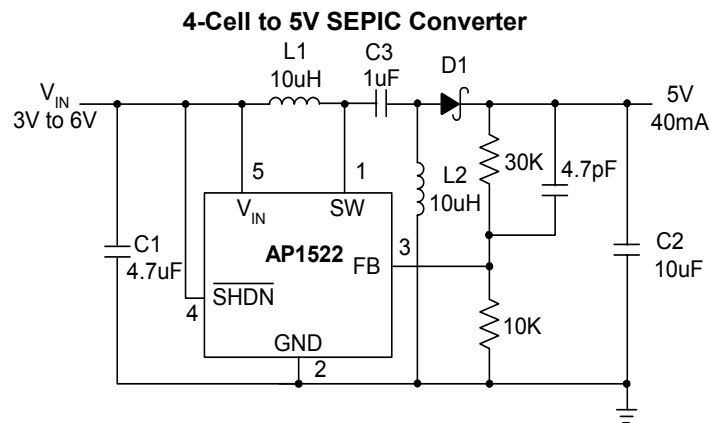
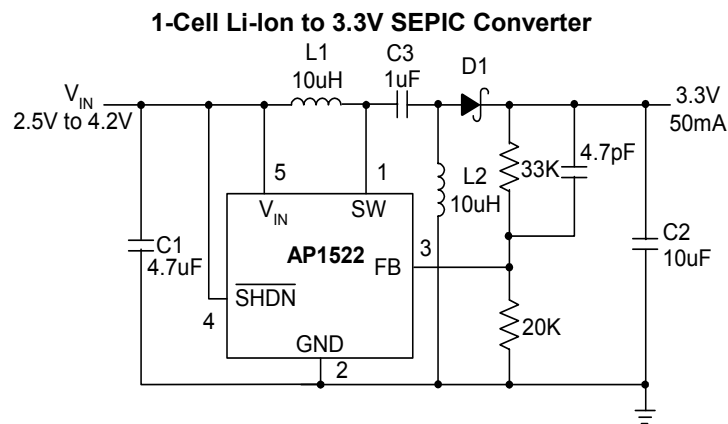
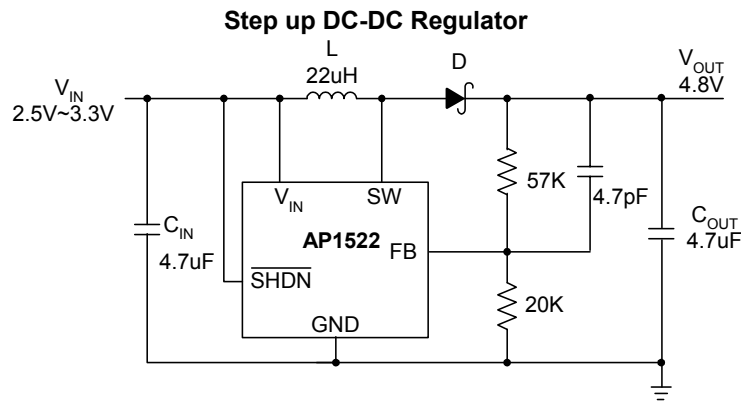

■ Typical Application Circuit (Continued)

±20V Dual Output Converter with Output Disconnect

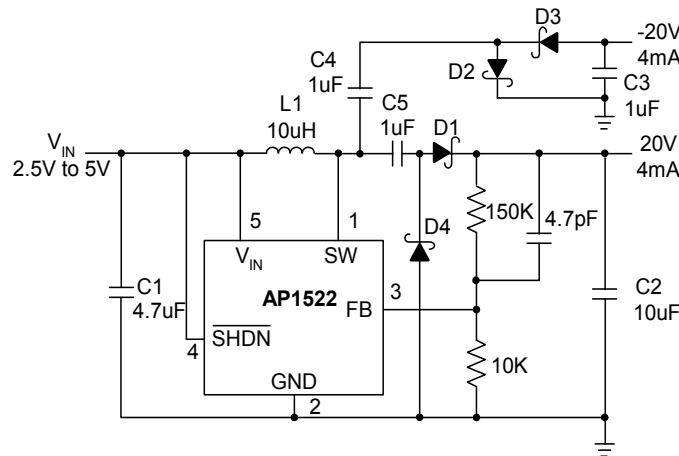

■ Applications Information

Inductor Selection

A 10μH inductor is recommended for most AP1522 applications. Although small size and high efficiency are major concerns, the inductor should have low core losses at 1MHz and low DCR (copper wire resistance).

Capacitor Selection

The small size of ceramic capacitors makes them ideal for AP1522 applications. X5R and X7R types are recommended because they retain their capacitance over wider voltage and temperature ranges than other types such as Y5V or Z5U. A 4.7μF input capacitor and a 4.7μF output capacitor are sufficient for most AP1522 applications.

Diode Selection

Schottky diodes, with their low forward voltage drop and fast reverse recovery, are the ideal choices for AP1522 applications. The forward voltage drop of a Schottky diode represents the conduction losses in the diode, while the diode capacitance (C_T or C_D) represents the switching losses. For diode selection, both forward voltage drop and diode capacitance need to be considered. Schottky diodes with higher current ratings usually have lower forward voltage drop and larger diode capacitance, which can cause significant switching losses at the 1MHz switching frequency of the AP1522. A Schottky diode rated at 100mA to 200mA is sufficient for most AP1522 applications.

Open-Circuit Protection

In the cases of output open circuit, when the R1 are disconnected from the circuit, the feedback voltage will be zero. The AP1522 will then switch at a high duty cycle resulting in a high output voltage, which may cause the SW pin voltage to exceed its maximum 36V rating. A zener diode can be used at the output to limit the voltage on the SW pin (Figure 1). The zener voltage should be larger than the maximum forward voltage of the V_{OUT} . The current rating of the zener should be larger than 0.1mA.

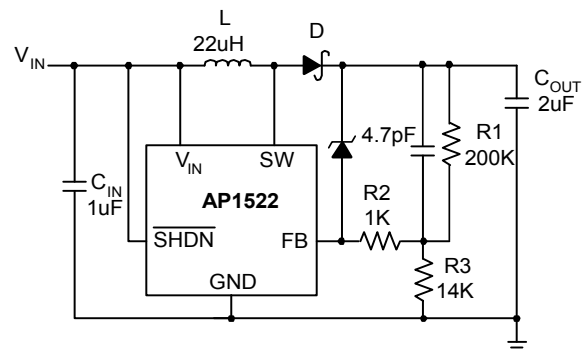
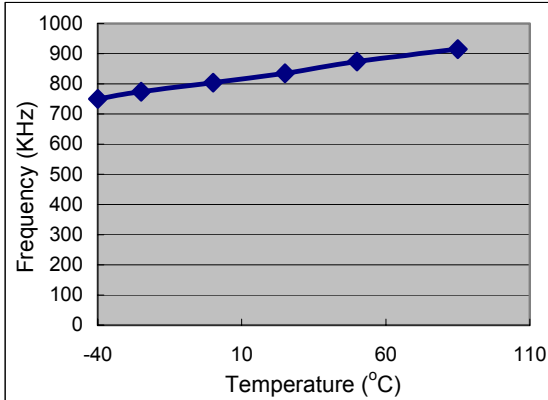

Figure 1. With Open-Circuit Protection

■ Typical Performance Characteristics

Frequency v.s. Temperature
Vin=5V; Vout=15V



Feedback Voltage v.s. Temperature
Vin=5V; Vout=15V

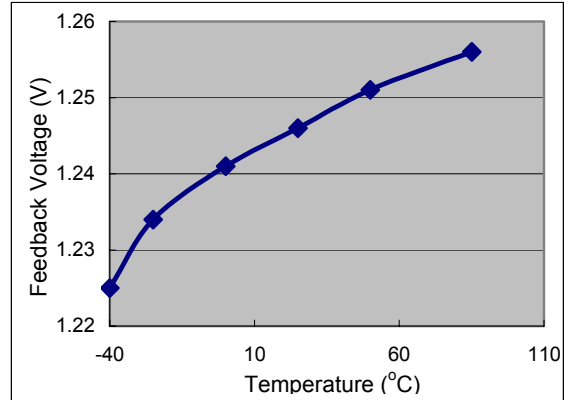

Supply Current v.s. Temperature
Vin=5V; Vout=15V; Iout=0A

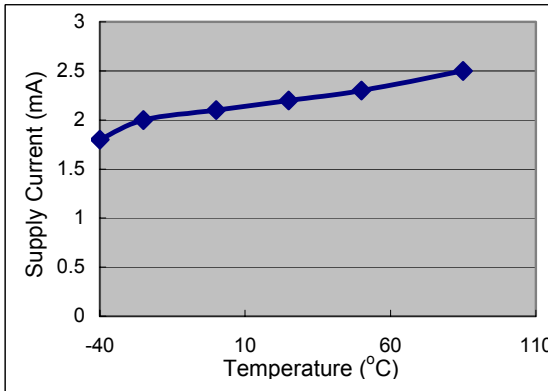

Supply Current v.s. Supply Voltage
Vout=15V; Iout=0A

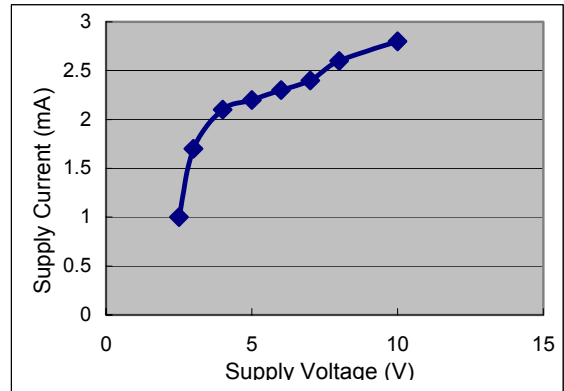

Efficiency v.s. Output Current
Vin=5V; Vout=15V

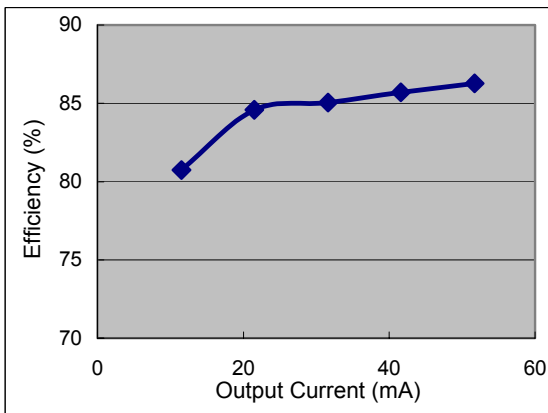

Efficiency v.s. Output Current
Vin=3.3V; Vout=15V

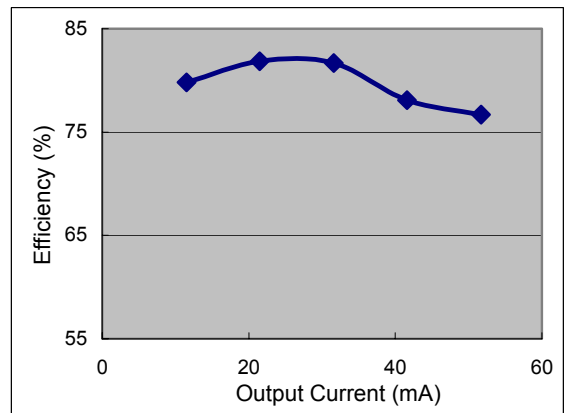

■ Typical Performance Characteristics (Continued)

Frequency v.s. Supply Voltage
Vout=15V

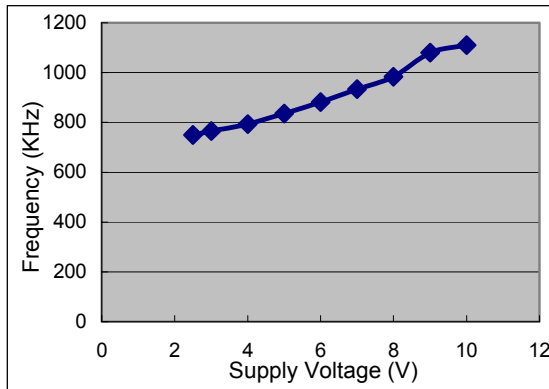

■ Marking Information

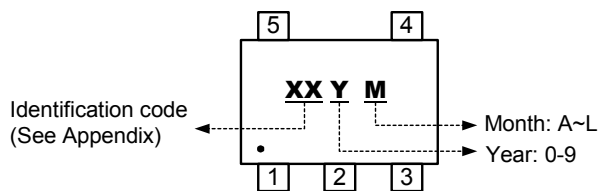

Appendix

Part Number	Package	Identification Code
AP1522	SOT23-5	FA

■ Package Information

Package Type: SOT23-5L

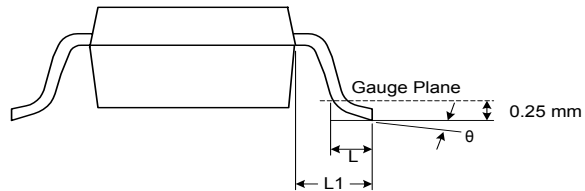
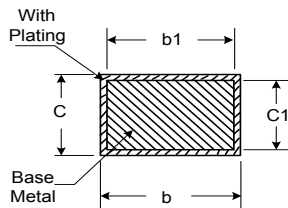
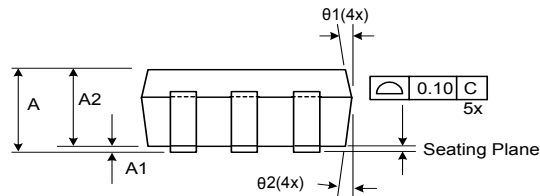
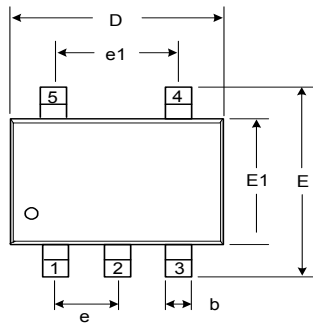

Symbol	Dimensions In Millimeters			Dimensions In Inches		
	Min.	Nom.	Max.	Min.	Nom.	Max.
A	1.05	1.20	1.35	0.041	0.047	0.053
A1	0.05	0.10	0.15	0.002	0.004	0.006
A2	1.00	1.10	1.20	0.039	0.043	0.047
b	0.25	-	0.55	0.010	-	0.022
b1	0.25	0.40	0.45	0.010	0.016	0.018
c	0.08	-	0.20	0.003	-	0.008
c1	0.08	0.11	0.15	0.003	0.004	0.006
D	2.70	2.85	3.00	0.106	0.112	0.118
E	2.60	2.80	3.00	0.102	0.110	0.118
E1	1.50	1.60	1.70	0.059	0.063	0.067
L	0.35	0.45	0.55	0.014	0.018	0.022
L1	0.60 Ref.			0.024 Ref.		
e	0.95 Bsc.			0.037 Bsc.		
e1	1.90 Bsc.			0.075 Bsc.		
θ	0°	5°	10°	0°	5°	10°
θ1	3°	5°	7°	3°	5°	7°
θ2	6°	8°	10°	6°	8°	10°