

Advance Information

Contact Monitoring and Dual Low Side Protected Driver

The MC33287 has been designed to interface between switching contacts (to battery or ground) and a microcontroller. This circuit includes 2 low side drivers, resistive and inductive loads or lamps.

- 8 High Voltage Input Triggers :
 - 1 Direct Output and 7 Multiplexed,
 - Direct Interface with Microcontroller
- 2 Low Side Drivers
 - Current Limitation : I_{lim} Typ = 0.5A (Each Output)
 - Internal Clamp : V_{clamp} Typ = 50V
 - Low Power Consumption in Standby Mode : $I_{max} = 110\mu A$
 - Overtemperature Protection (Typical 160°C)
 - Outputs Fault Detection

MC33287

Contact Monitoring and Dual Low Side Protected Driver

SEMICONDUCTOR
TECHNICAL DATA



DW SUFFIX
PLASTIC PACKAGE
SO20L

PIN ASSIGNMENT

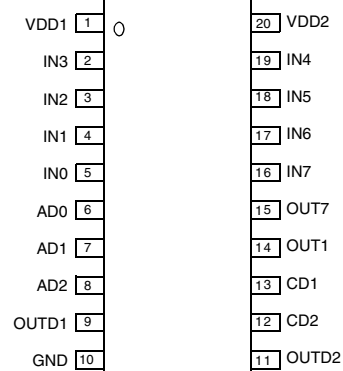

ORDERING INFORMATION

Device	Temperature Range	Package
MC33287DW	-40°C to +125°C	SO20L

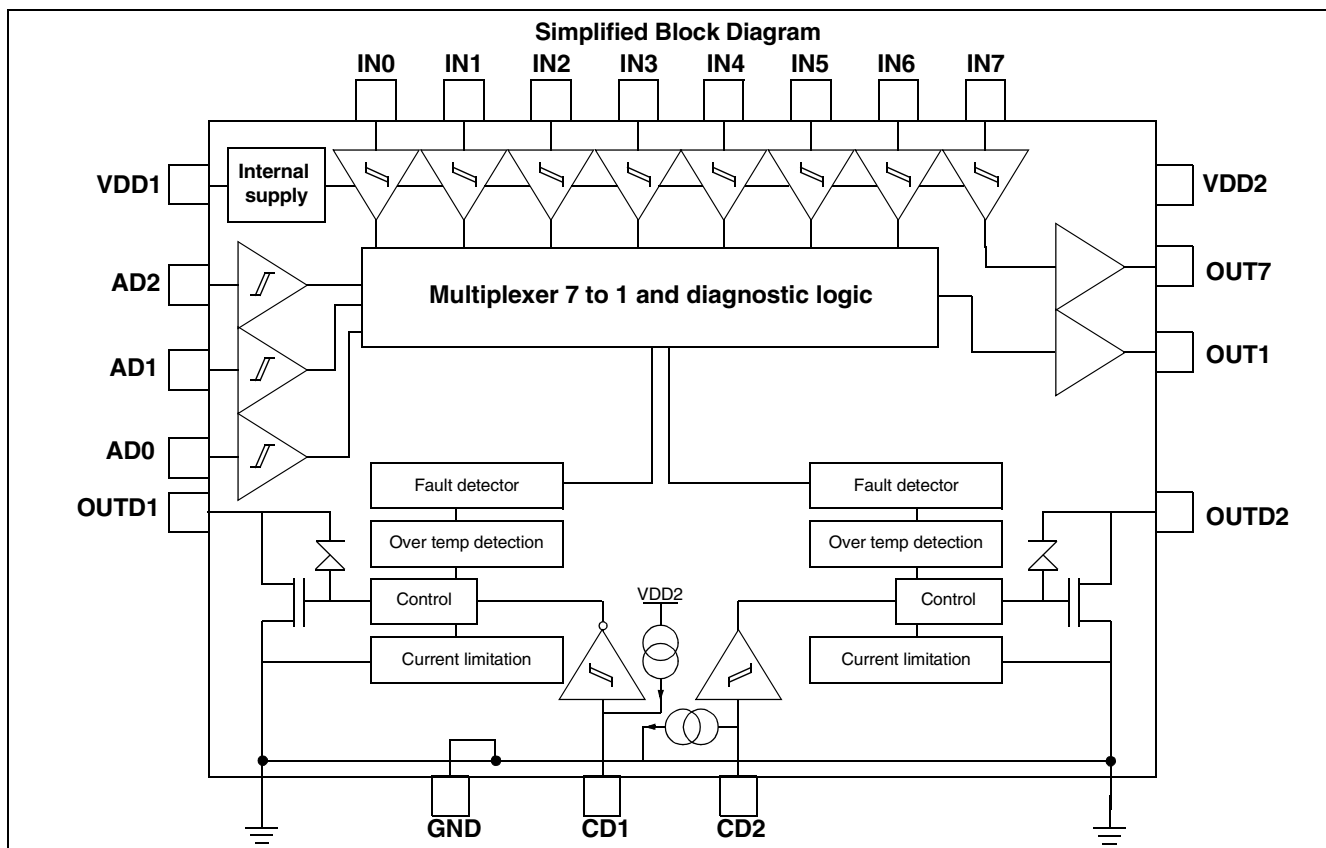

This document contains information on a new product. Specifications and information herein are subject to change without notice.

MAXIMUM RATINGS

Ratings	Symbol	Min	Typ	Max	Unit
Operating Ambient Temperature	Tamb	- 40		85	°C
Storage Ambient Temperature	Tstorage	- 65		105	°C
Supply Voltage (Load Dump Conditions)	VDD1			40	V
Supply Voltage (Continuous)	VDD1			24	V
Supply Voltage (Continuous)	VDD2			7	V
Input Voltage On Pin IN1 (With Serial Resistor $\geq 25k\Omega$)	VIN			40	V
Total Power Dissipation (Tamb = 85°C)	Pd			0,7	W
V ESD (Note MIL STD 883C)	VESD	- 2000		+ 2000	V
Thermal Resistance Jonction To Air (Circuit Soldered On Pcb)	Rth(j-a)		80	100	°C/W

ELECTRICAL CHARACTERISTICS. Full specification is $7V \leq V_{DD1} \leq 18V$; $4,75V \leq V_{DD2} \leq 5,25V$; $-40^{\circ}C \leq t_{amb} \leq 85^{\circ}C$, unless otherwise noted. Extended limit is : $5V \leq V_{DD1} \leq 7V$ and other parameters are full spec. in this mode, inputs IN1 and lowside drivers are still fonctionnal with downgraded characteristics.

Parameters	Symbol	Min	Typ	Max	Unit
------------	--------	-----	-----	-----	------

SUPPLY VOLTAGE : VDD1 and VDD2 Pins

Operational Supply Voltage (Full Spec)	VDD1	7	12	18	V
Operational Supply Voltage (Extend limit)	VDD1	5		7	V
Operational Supply Voltage (Full Spec)	VDD2	4.75	5	5.25	V
Supply Current Standby Mode ($V_{DD1} \leq 14V$; $V_{CD1} = V_{DD2}$, $V_{CD2} = 0V$) All IN1 and AD1 inputs connected to ground	IVDD1-0 IVDD2-0		55	110	μA
Supply Current in Drivers on Configuration (Full Spec ; $V_{CD1} = 0V$; $V_{CD2} = V_{DD2}$) All INi and ADi inputs connected to ground	IVDD1-1 IVDD2-1		250 650	1500 1500	μA

DRIVERS CHARACTERISTICS : Output Driver Characteristics : OUTD1 and OUTD2 Pins

Output Resistance (Full Spec and $T_j \leq 130^{\circ}C$)	Rdson		1.40	3.20	Ω
Output Resistance (Extend limit and $T_j \leq 130^{\circ}C$)	Rdson			5.00	Ω
Leakage Current (Internal current source)	ILeakage	1		13	μA
Turn On Delay Time	t _{ON}		1.3	10	μs
Turn Off Delay Time	t _{OFF}		2.1	10	μs
Output Rising Edge	t _{RISE}		2.8	10	μs
Output Falling Edge	t _{FALL}		1.0	10	μs
Difference between command duration and bit duration	Δbit	- 5		5	μs

Figure 1. Timing Test Configuration

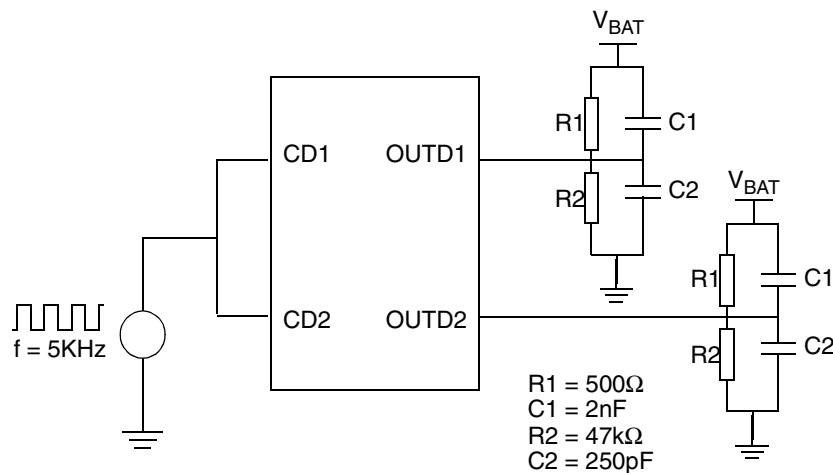
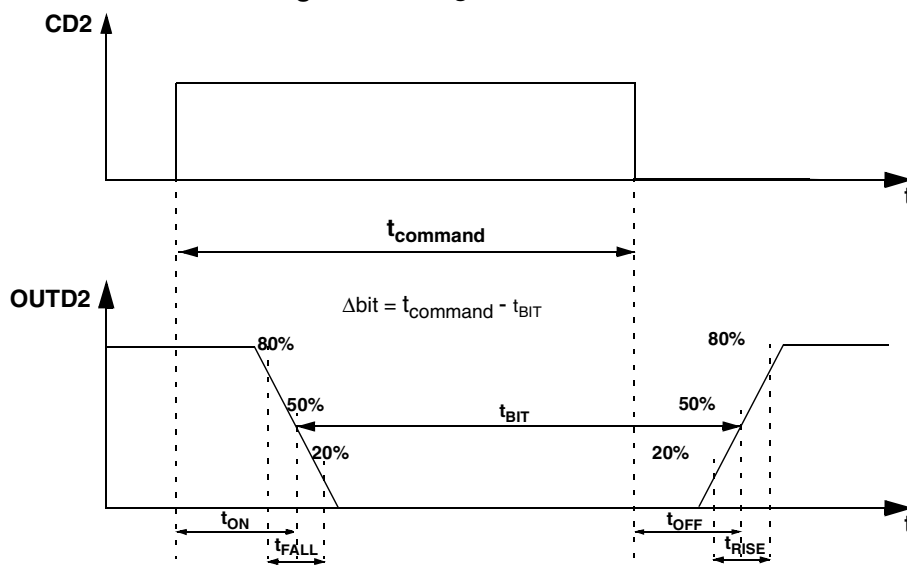

Figure 2. Timing Characteristics



PROTECTION AND LEVEL DETECTION : OUTD1 AND OUTD2 PINS

Parameters	Symbol	Min	Typ	Max	Unit
Positive Output Clamp	Vclamp	40	50	60	V
Output Current Limitation (130°C ≥ T _j)	Ilim	300	535	750	mA
Output Fault Detector Level	Vfault	2,00	2,75	3,5	V
Overtemperature Detection (At 25°C by function simulation)	Tdetec	145	160	175	°C

INPUTS : CD1 AND CD2 PINS

Input Voltage Low	V _{il}			0,4 x VDD2	V
Input Voltage High	V _{ih}	0,8 x VDD2			V
Hysteresis	V _{hys}	500	800		mV
Input Current on Pin CD1 (Internal pull up and CD1 connected to ground)	ICD1	-100	-30	-10	μA
Leakage Current on Pin CD1 (Internal pull-up CD1 connected to VDD2)	Ileakage	-5		5	μA
Input Current on Pin CD2 (Internal pull down CD2 connected to VDD2)	ICD2	10	30	100	μA

PROTECTION AND LEVEL DETECTION : OUTD1 AND OUTD2 PINS

Parameters	Symbol	Min	Typ	Max	Unit
Leakage Current on Pin CD2 (Internal pull-up CD1 connected to ground)	Ileakage	-5		5	μA

DRIVERS FUNCTION TABLE : Outputs and fault detector status (Diag)

CD1	OUTD1	DIAGD1	Status
h	H	h	Driver 1 normally OFF
l	L	h	Driver 1 normally ON
h	L	l	Driver 1 shorted to GND or open load
l	H	l	Driver 1 over loaded

CD2	OUTD2	DIAGD2	Status
l	H	h	Driver 2 normally OFF
h	L	h	Driver 2 normally ON
l	L	l	Driver 2 shorted to GND or open load
h	H	l	Driver 2 over loaded

H = High Level for Drivers Outputs, L = Low Level for Drivers Outputs
h = High Level for Logic Signals, l = Low Level for Logic Signals.

NOTES : CD1 is active on low level (driver 1 is on when CD1 is low), CD2 is active on high level (driver 2 is on when CD2 is high). The DIAGD1 output is neither latched for filtered.

LOGIC CHARACTERISTICS

Characteristic	Symbols	Min	Typ	Max	Unit
----------------	---------	-----	-----	-----	------

INPUTS : Pins IN0 to IN7

Input Voltage Low (Full Spec)	Vil			0,4 x VDD1	V
Input Voltage Low (Extended Limit)	Vil			0,3 x VDD1	V
Input Voltage High (Full Spec and Extended Limit)	Vih	0,7 x VDD1			V
Hysteresis ($5\text{V} \leq \text{VDD1} \leq 16\text{V}$)	Vhys	0,5	1		V
Input Current ($V_{in} \leq 16\text{V}$)	Ileakage	- 5		5	μA
Input Voltage Clamp ($I = 100\mu\text{A}$)	Vin clamp	17	20	23	V

INPUTS : AD0, AD1, AD2 Pins

Input Voltage Low	Vil			0,4 x VDD2	V
Input VoltageHigh	Vih	0,8 x VDD2			V
Hysteresis	Vhys	500	750		mV
Input Current	Ileakage	- 5		5	μA

8 LINE TO 1 LINE DATA MULTIPLEXER FUNCTION TABLE

Inputs			OUT1
AD2	AD1	AD0	
x	x	x	-
l	l	l	in0
l	l	h	in1
l	h	l	in2
l	h	h	in3
h	l	l	in4
h	l	h	in5
h	h	l	in6
h	h	h	DIAGDi

h = High Level, l = Low Level, x = high impedance, - unknown.
 DIAGDi is the value of the selectionned internal fault detector (See below)
 in0, in1...in6 are the normalised values of the INi respectives inputs
 (INi = Vbat -ini = VDD2)

FAULT DETECTOR SELECTION. This table presents the sequential patterns which enable to select the diagnostic of driver 1 (diagd1) or driver 2 (diagd2)

Inputs			OUTi
AD2	AD1	AD0	
-	-	-	-
-	l	h	-
h	h	h	DIAGD1
-	-	-	-
-	h	l	-
h	h	h	DIAGD2

h = High Level, l = Low Level, x = high impedance, - unknown.

OUTPUTS : OUT1 AND OUT7 PINS

Parameters	Symbols	Min	Typ	Max	Unit
Output Voltage Low (Iload = 2mA)	V _{ol}			0,2 VDD2	V
Output Voltage High (Iload = - 2mA)	V _{oh}	0,8 VDD2			V

PINS FUNCTION DESCRIPTION

Pin Number	Name	Description
1	VDD1	High Voltage Power Supply (Vbat)
2	IN3	High Voltage Input 3
3	IN2	High Voltage Input 2
4	IN1	High voltage input 1
5	IN0	High Voltage Input 0
6	AD0	Adress for Mode and Input Selection
7	AD1	Adress for Mode and Input Selection
8	AD2	Adress for Mode and Input Selection
9	OUTD1	Output Driver 2 (Drain)
10	GND	Common Ground
11	OUTD2	Output Driver 2 (Drain)
12	CD2	Driver 2 command
13	CD1	Driver 1 command
14	OUTI	Output (Multiplexed output i = 0 to 6) and Diagi2
15	OUT7	Output 7 (Direct Output from IN7)
16	IN7	High Voltage Input 7
17	IN6	High Voltage Input 6
18	IN5	High Voltage Input 5
19	IN4	High Voltage Input 4
20	VDD2	Low Voltage Power Supply (5v)

MC33287
APPLICATION

Figure 3. Typical Application Configuration

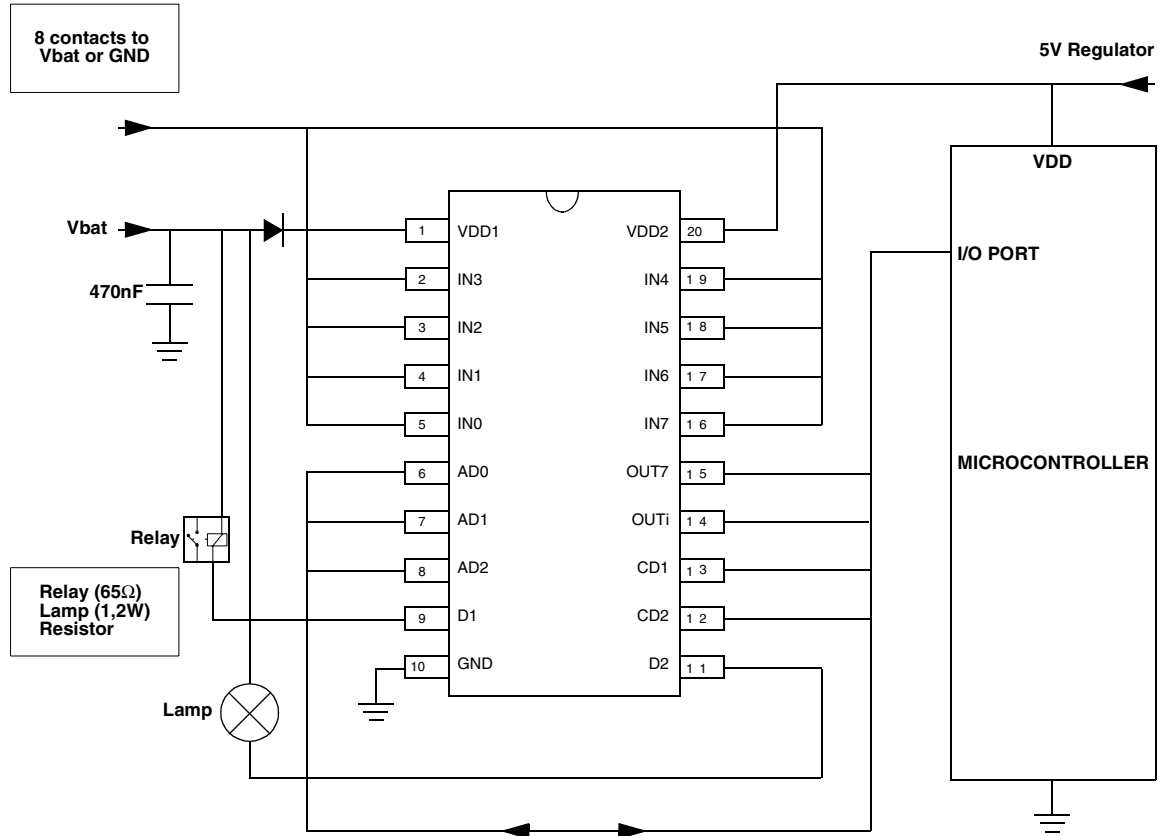

Figure 4. Contact Configuration

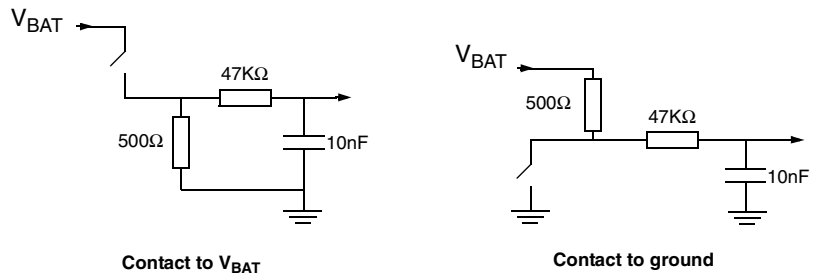
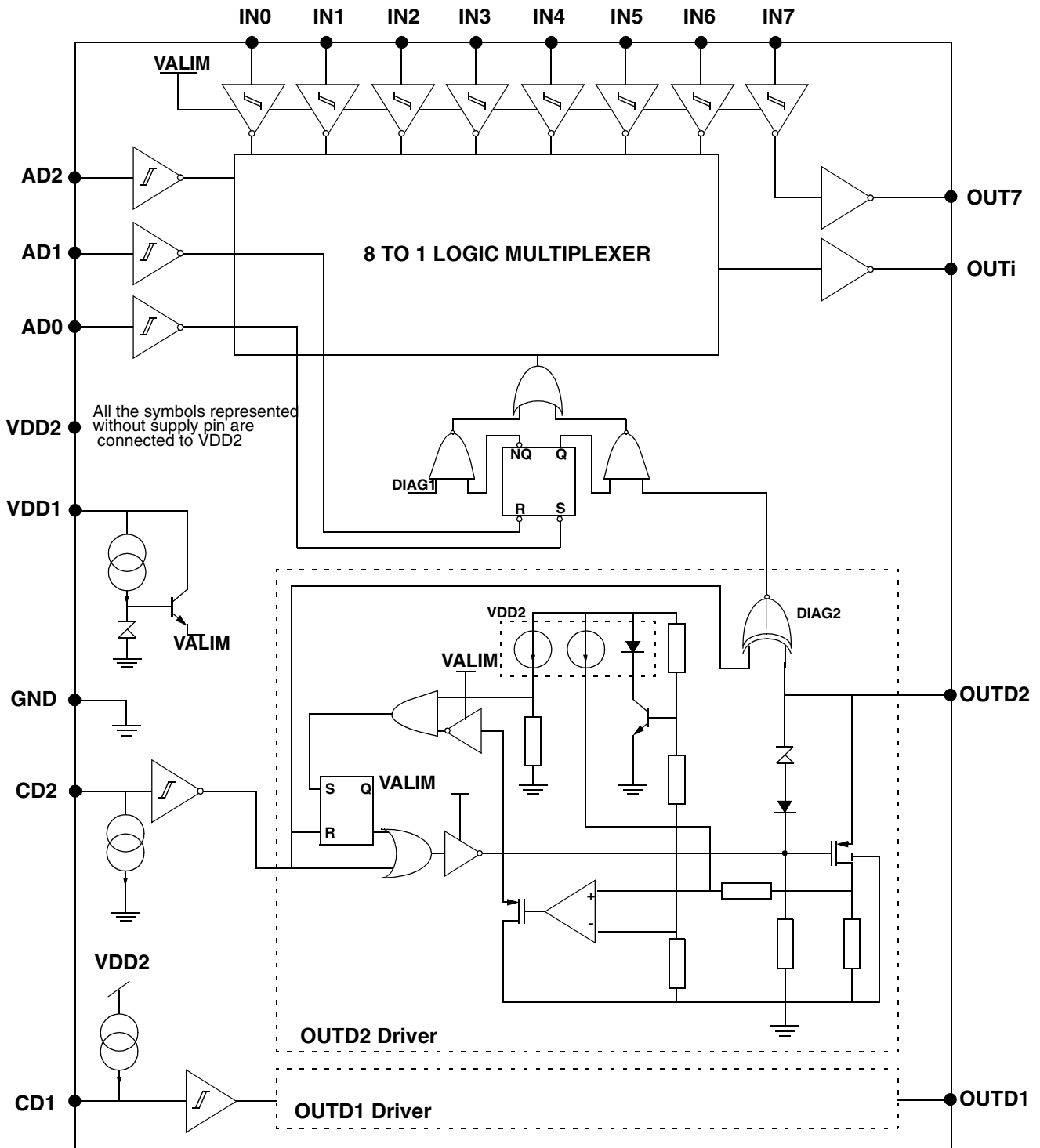
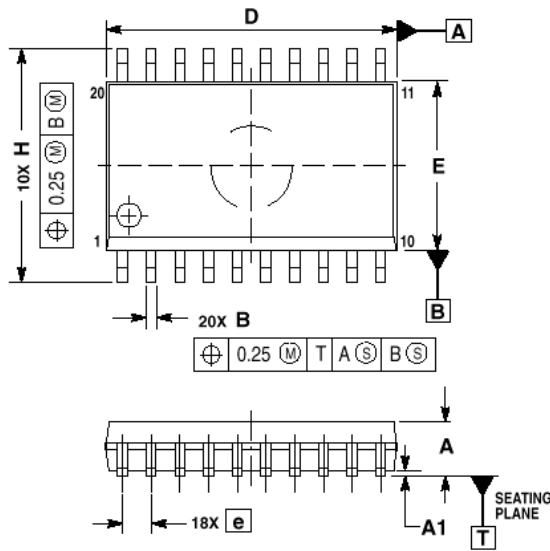

Figure 5. Electrical Schematic



NOTE : The only difference between the low side driver 1 and 2 is the polarity of the command. Also, there are an internal pull-up at pin CD1, an internal pull-down at pin CD2 and an extra inverted is placed after the CD1 input trigger.



- NOTES:
1. DIMENSIONS ARE IN MILLIMETERS.
 2. INTERPRET DIMENSIONS AND TOLERANCES PER ASME Y14.5M, 1994.
 3. DIMENSIONS D AND E DO NOT INCLUDE MOLD PROTRUSION.
 4. MAXIMUM MOLD PROTRUSION 0.15 PER SIDE.
 5. DIMENSION B DOES NOT INCLUDE DAMBAR PROTRUSION. ALLOWABLE PROTRUSION SHALL BE 0.13 TOTAL IN EXCESS OF B DIMENSION AT MAXIMUM MATERIAL CONDITION.

DIM	MILLIMETERS	
	MIN	MAX
A	2.35	2.65
A1	0.10	0.25
B	0.35	0.49
C	0.23	0.32
D	12.65	12.95
E	7.40	7.60
e	1.27 BSC	
H	10.05	10.55
h	0.25	0.75
L	0.50	0.90
θ	0	7

Motorola reserves the right to make changes without further notice to any products herein. Motorola makes no warranty, representation or guarantee regarding the suitability of its products for any particular purpose, nor does Motorola assume any liability arising out of the application or use of any product or circuit, and specifically disclaims any and all liability, including without limitation consequential or incidental damages. "Typical" parameters which may be provided in Motorola data sheets and/or specifications can and do vary in different applications and actual performance may vary over time. All operating parameters, including "Typical" must be validated for each customer application by customer's technical experts. Motorola does not convey any license under its patent rights nor the rights of others. Motorola products are not designed, intended, or authorized for use as components in systems intended for surgical implant into the body, or other applications intended to support or sustain life, or for any application in which the failure of the Motorola product could create a situation where personal injury or death may occur. Should Buyer purchase or use Motorola products for any such unintended or unauthorized application, Buyer shall indemnify and hold Motorola and its officers, employees, subsidiaries, affiliates, and distributors harmless against all claims, costs, damages, and expenses, and reasonable attorney fees arising out of, directly or indirectly, any claim of personal injury or death associated with such unintended or unauthorized use, even if such claim alleges that Motorola was negligent regarding the design or manufacture of the parts. Motorola and  are registered trademarks of Motorola, Inc. Motorola, Inc. is an Equal Employment Opportunity/Affirmative Action Employer.

How to reach us:

USA / EUROPE / Locations Not Listed: Motorola Literature Distribution; P.O. Box 5405, Denver, Colorado 80217. 1-303-675-2140 or 1-800-441-2447

JAPAN: Motorola Japan Ltd.; SPS, Technical Information Center, 3-20-1, Minami-Azabu, Minato-ku, Tokyo 106-8573 Japan. 81-3-344-3569

Technical Information Center: 1-800-521-6274

ASIA / PACIFIC: Motorola Semiconductors H.K. Ltd.; Silicon Harbour Centre, 2, Dai King Street, Tai Po Industrial Estate, Tai Po, N.T., Hong Kong. 852-26668334

HOME PAGE: <http://www.motorola.com/semiconductors>