

### Features

**Patent Number: 86474, 113235(R.O.C.), 5424740(U.S.A.)**

- Universal specification
- Operating voltage: 2.0V~5.5V
- Low standby current
- Low memory retention current: 0.1μA (Typ.)
- Tone/pulse switchable
- Interface with LCD driver
- 32 digits for redialing
- 32 digits for SA memory dialing
- One-key redialing
- Pause and P→T key for PBX
- 5×5 keyboard matrix
- Make/Break ratio control
- 3.58MHz crystal or ceramic resonator
- Hand-free control
- Hold-line control
- Pause, P→T can be saved for redialing
- Memory number: 15 memories
- Keytone function
- Lock function
- CD key

### General Description

The HT9245 series tone/pulse dialers are CMOS LSIs for telecommunication systems.

The HT9245 series are offered in various packages from 22-pin DIP to 28-pin DIP. The 22-pin DIP version is suitable for low cost applications, while the 28-pin DIP version supplies versatile functions such as: Hold-line, Hand-free, IDD

lock and LCD dialing number display interface, all of which are suitable for feature phone applications.

The HT9245 provides SA, Redial, 3 one-touch and 10 two-touch memory dials for speed dialing in either pulse or tone mode.

### Selection Table

Function Item	Memory Dialing	Hold-Line	Hand-Free	LCD Interface	Flash Function	Flash Time (ms)	Pulse No.	Tone Duration (ms)	Inter-Tone-Pause (ms)	Lock Function	Package
HT9245A	SA,R EM1~EM3 M0~M9	—	—	—	Control	98/300/600	N	91	91	—	22 DIP
HT9245B	SA,R EM1~EM3 M0~M9	—	√	—	Control	98/300/600	N	91	91	—	24 DIP
HT9245AL	SA,R EM1~EM3 M0~M9	—	—	—	Control	98/300/600	N	91	91	√	22 DIP
HT9245BL	SA,R EM1~EM3 M0~M9	—	√	—	Control	98/300/600	N	91	91	√	24 DIP
HT9245CL	SA,R EM1~EM3 M0~M9	—	—	√	Control	98/300/600	N	91	91	√	24 DIP
HT9245DL	SA,R EM1~EM3 M0~M9	√	√	√	Control	98/300/600	N	91	91	√	28 DIP

**Pin Assignment**

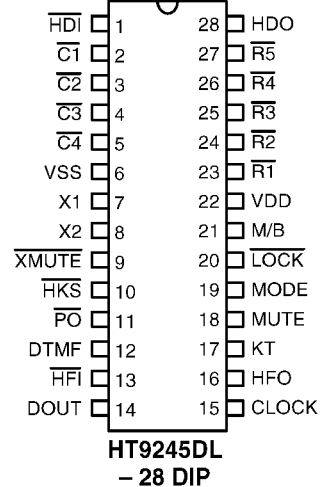
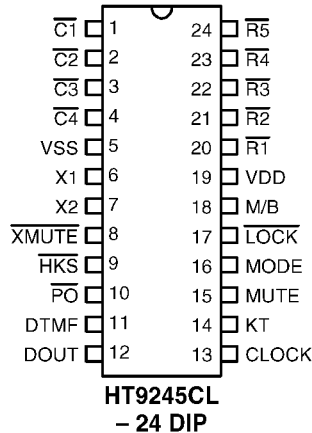
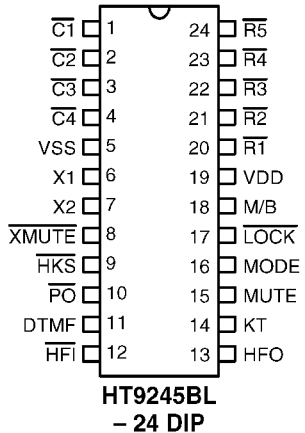
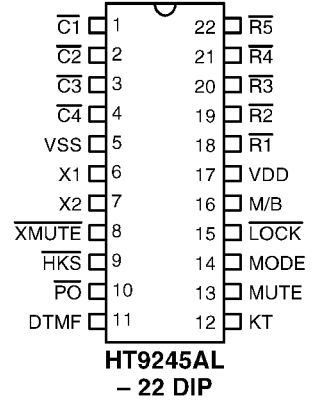
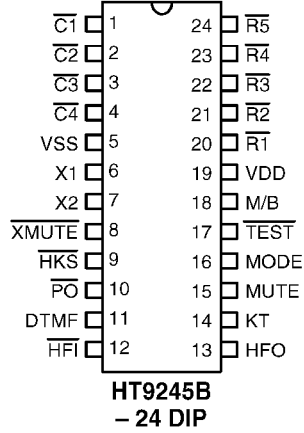
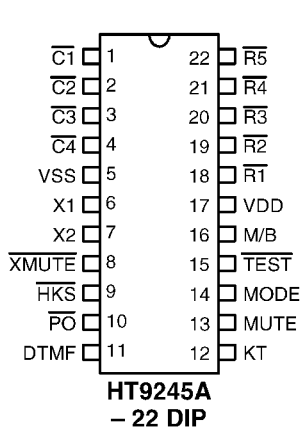

**Keyboard Information**

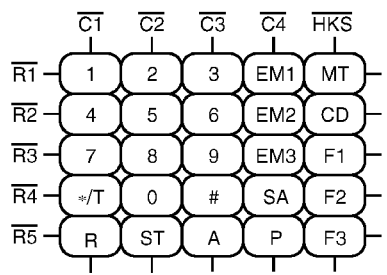

**Block Diagram**

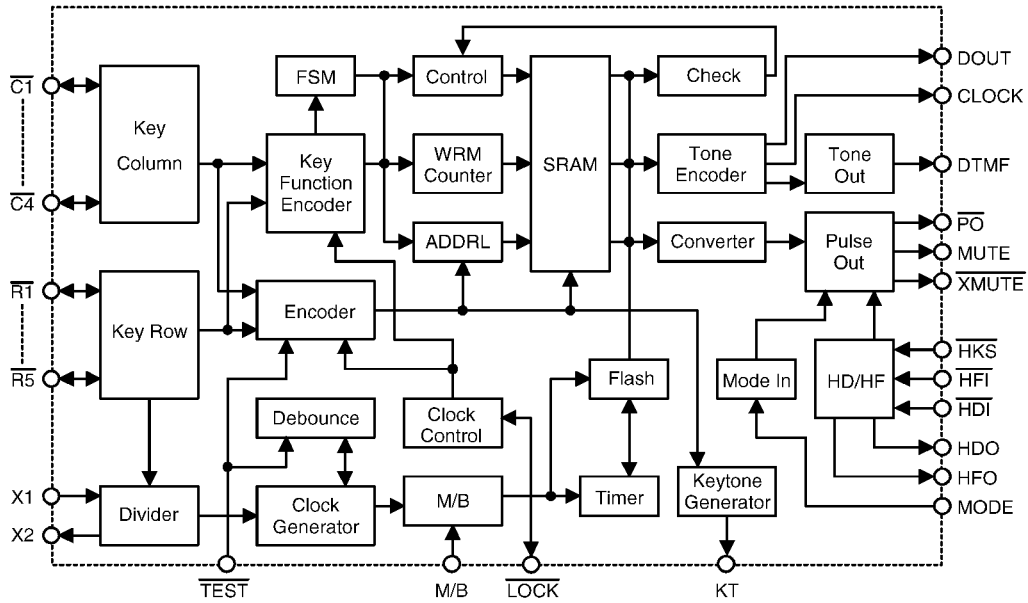

**Pin Description**

Pin Name	I/O	Internal Connection	Description
$\overline{C1}\sim\overline{C4}$ $\overline{R1}\sim\overline{R5}$	I/O	CMOS IN/OUT	<p>These pins form a 5x5 keyboard matrix which can perform keyboard input detection. When on-hook (<math>\overline{HKS}</math>= high) all the pins are set high. While off-hook the column group (<math>\overline{C1}\sim\overline{C4}</math>) remains low and the row group (<math>\overline{R1}\sim\overline{R5}</math>) is set high for key input detection.</p> <p>An inexpensive single contact 5x5 keyboard can be used as an input device. Pressing a key connects a single column to a single row, and actuates the system oscillator that results in a dialing signal output. If more than two keys are pressed at the same time, no response occurs. The key-in debounce time is 20ms. Refer to the keyboard information for keyboard arrangement and to the functional description for dialing specification selection.</p>
X1	I	OSCILLATOR	<p>The system oscillator consists of an inverter, a bias resistor and the necessary load capacitor on chip. Connecting a standard 3.579545MHz crystal or ceramic resonator to the X1 and X2 terminals can implement the oscillator function. The oscillator is turned off in the standby mode, and is actuated whenever a keyboard entry is detected.</p>
X2	O		

Pin Name	I/O	Internal Connection	Description
$\overline{\text{XMUTE}}$	O	CMOS OUT	$\overline{\text{XMUTE}}$ is a CMOS output structure pulled to VSS during dialing signal transmission. Otherwise, it remains "high". $\overline{\text{XMUTE}}$ is used to mute the speech circuit when transmitting the dial signal.
$\overline{\text{HKS}}$	I	CMOS IN Pull-High	This pin is used to monitor the status of the hook-switch and its combination with $\overline{\text{HFI}}$ can control the $\overline{\text{PO}}$ pin output to make or break the line. $\overline{\text{HKS}}=\text{VDD}$ : On-hook state ( $\overline{\text{PO}}=\text{low}$ ). Except $\overline{\text{HFI}}/\overline{\text{HD}}$ (hand-free/hold-line control input), other functions are all disabled. $\overline{\text{HKS}}=\text{VSS}$ : Off-hook state ( $\overline{\text{PO}}=\text{high}$ ). The chip is in the standby mode and ready to receive the key input.
$\overline{\text{PO}}$	O	CMOS OUT	This pin is a CMOS output structure which by receiving the $\overline{\text{HKS}}$ and HFO signals, control the dialer to connect or disconnect the telephone line. $\overline{\text{PO}}$ outputs a low to break the line when $\overline{\text{HKS}}$ is high (on-hook) and HFO is low (hand-free inactive). $\overline{\text{PO}}$ outputs a high to make the line when $\overline{\text{HKS}}$ is low (off-hook) or HFO is high or HDO is high. During the off-hook state, this pin also outputs the dialing pulse train in pulse mode dialing. While in the tone mode, this pin is always high.
MODE	I	CMOS IN	This is an input pin, used for dialing mode selection, either Tone mode or Pulse mode, 10pps MODE=VDD: Pulse mode, 10pps MODE=VSS: Tone mode During pulse mode dialing, switching this pin to the tone mode changes the subsequent digit entry to tone mode. When the chips are in tone mode, switching to pulse mode will also be recognized.
MUTE	O	CMOS OUT	MUTE is a CMOS output structure pulled to VDD during Tone (DTMF) output transmission. Otherwise, it continuously remains "low".
M/B	I	CMOS IN	This is a Make/Break ratio selection pin in pulse mode. Otherwise, it has no function. M/B=VDD: Make/Break ratio is 40/60 M/B=VSS: Make/Break ratio is 33/66
DTMF	O	CMOS OUT	This pin is active only when the chip transmits tone dialing signals. Otherwise, it always outputs a low. The pin outputs tone signals to drive the external transmitter amplifier circuit. The load resistor should not be less than 5k $\Omega$ .

Pin Name	I/O	Internal Connection	Description
$\overline{\text{HDI}}$	I	CMOS IN Pull-High	This pin is a schmitt trigger input structure. Active low. Applying a negative going pulse to this pin can toggle the HDO output once. An external RC network is recommended for input debouncing. The pull-high resistance is 200k $\Omega$ typ.
HDO	O	CMOS OUT	The HDO is a CMOS output structure. Its output is toggle-controlled by a negative transition on $\overline{\text{HDI}}$ . When HDO is toggled high, $\overline{\text{PO}}$ keeps high to hold the line. The hold function can be released by setting $\overline{\text{HFO}}$ high or by an on-off hook operation or by another $\overline{\text{HDI}}$ input. The HDO pin can directly drive the HT3810 series melody generators to produce a hold-line background melody. Refer to the functional description for the hold-line function.
$\overline{\text{HFI}}$	I	CMOS IN Pull-High	This pin is a schmitt trigger input structure. Active low. Applying a negative going pulse to $\overline{\text{HFI}}$ can toggle HFO once and hence control the hand-free function. The pull-high resistance of $\overline{\text{HFI}}$ is 200k $\Omega$ typ. An external RC network is recommended for input debouncing.
HFO	O	CMOS OUT	The HFO is a CMOS output structure. Its output is toggle-controlled by a negative transition on the $\overline{\text{HFI}}$ pin. When HFO is high, the hand-free function is enabled and $\overline{\text{PO}}$ outputs a high to connect the line. The hand-free function can be released by an on-off-hook operation or by another $\overline{\text{HFI}}$ input or by setting HDO high. Refer to the functional description for the hand-free functional operation.
DOUT	O	NMOS OUT	NMOS open drain output pin. It outputs the BCD code of the dialing digits to the LCD driver chip (HT16XX series) or $\mu\text{C}$ for dialing number display. Refer to the functional description for the detailed timing.
CLOCK	O	NMOS OUT	NMOS open drain output. When dialing, it outputs a series of pulse trains for DOUT data synchronization. DOUT data is valid at the falling edge of the clock.
KT	O	CMOS OUT	Keytone output pin. Outputs a 1.2kHz tone carrier when any key is pressed in the pulse mode or when the function keys are pressed in the Tone (DTMF) mode.
$\overline{\text{TEST}}$	I	CMOS IN	For IC test only. $\overline{\text{TEST}}=\text{VDD}$ for normal operation

Pin Name	I/O	Internal Connection	Description
$\overline{\text{LOCK}}$	I/O	CMOS IN/OUT	This is a three-state input-output pin, used for controlling long distance call function with a lock-switch. LOCK=VDD: Normal dialing LOCK=OPEN: "0,9" is inhibited for use as the first key input LOCK=VSS: "0" is inhibited for use as the first key input
VDD	I	—	Positive power supply, 2.0V~5.5V for normal operation
VSS	I	—	Negative power supply

**Approximate internal connection circuits**

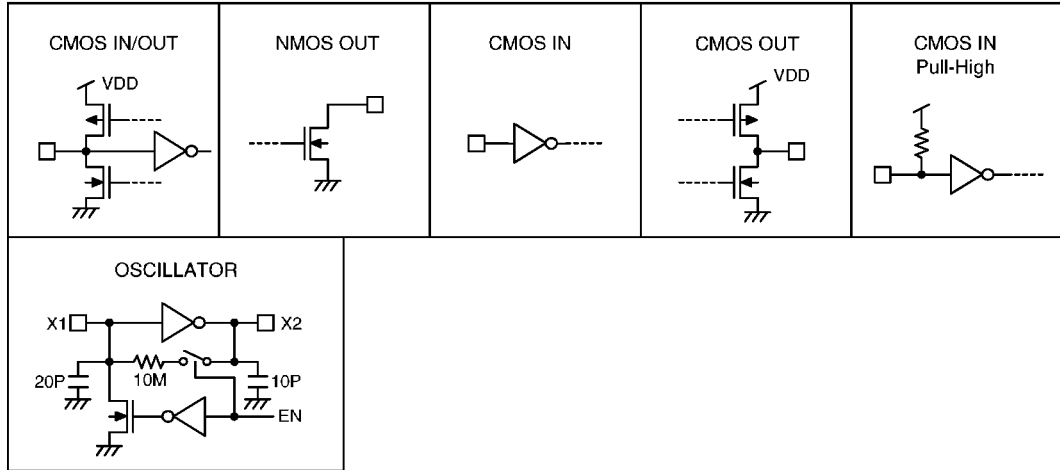

**Absolute Maximum Ratings\***

Supply Voltage .....	-0.3V to 6V	Storage Temperature .....	-50°C to 125°C
Input Voltage .....	V <sub>SS</sub> -0.3 to V <sub>DD</sub> +0.3V	Operating Temperature .....	-20°C to 75°C

\*Note: Stresses above those listed under "Absolute Maximum Ratings" may cause permanent damage to the device. These are stress ratings only. Functional operation of this device at these or any other conditions above those indicated in the operational sections of this specification is not implied and exposure to absolute maximum rating conditions for extended periods may affect device reliability.

**Electrical Characteristics**

 (F<sub>OSC</sub>=3.5795MHz, T<sub>a</sub>=25°C)

Symbol	Parameter	Test Conditions		Min.	Typ.	Max.	Unit	
		V <sub>DD</sub>	Conditions					
V <sub>DD</sub>	Operating Voltage	—	—	2	—	5.5	V	
I <sub>DD</sub>	Operating Current	2.5V	Pulse	Off-hook Keypad entry No load	—	0.2	1	mA
			Tone		—	0.6	2	mA
I <sub>STB</sub>	Standby Current	1V	On-hook, no load No entry	—	—	1	μA	
V <sub>R</sub>	Memory Retention Voltage	—	—	1	—	5.5	V	
I <sub>R</sub>	Memory Retention Current	1V	On-hook	—	0.1	0.2	μA	
V <sub>IL</sub>	Input Low Voltage	—	—	V <sub>SS</sub>	—	0.2V <sub>DD</sub>	V	
V <sub>IH</sub>	Input High Voltage	—	—	0.8V <sub>DD</sub>	—	V <sub>DD</sub>	V	
I <sub>OHXM</sub>	Mute Pin Source Current ( $\overline{\text{XMUTE}}$ , MUTE)	2.5V	V <sub>OH</sub> =2V	-1	—	—	mA	
I <sub>OLXM</sub>	Mute Pin Sink Current ( $\overline{\text{XMUTE}}$ , MUTE)	2.5V	V <sub>OL</sub> =0.5V	1	—	—	mA	
I <sub>HKS</sub>	$\overline{\text{HKS}}$ Pin Input Current	2.5V	V <sub>HKS</sub> =2.5V	—	—	0.1	μA	
R <sub>HFI</sub>	$\overline{\text{HFI}}$ Pull-High Resistance	2.5V	V <sub>HFI</sub> =0V	—	200	—	kΩ	
R <sub>HDI</sub>	$\overline{\text{HDI}}$ Pull-High Resistance	2.5V	V <sub>HDI</sub> =0V	—	200	—	kΩ	
R <sub>HKS</sub>	$\overline{\text{HKS}}$ Pull-High Resistance	2.5V	V <sub>HKS</sub> =0V	—	1	—	MΩ	
T <sub>F1</sub>	Flash Time for F1 Key	—	—	—	98	—	ms	
T <sub>F2</sub>	Flash Time for F2 Key	—	—	—	300	—	ms	
T <sub>F3</sub>	Flash Time for F3 Key	—	—	—	600	—	ms	
I <sub>OH1</sub>	Keypad Pin Source Current	2.5V	V <sub>OH</sub> =0V	-4	—	-40	μA	
I <sub>OL1</sub>	Keypad Pin Sink Current	2.5V	V <sub>OL</sub> =2.5V	200	400	—	μA	
I <sub>OH2</sub>	HFO Pin Source Current	2.5V	V <sub>OH</sub> =2V	-1	—	—	mA	
I <sub>OL2</sub>	HFO Pin Sink Current	2.5V	V <sub>OL</sub> =0.5V	1	—	—	mA	
I <sub>OH3</sub>	HDO Pin Source Current	2.5V	V <sub>OH</sub> =2V	-1	—	—	mA	
I <sub>OL3</sub>	HDO Pin Sink Current	2.5V	V <sub>OL</sub> =0.5V	1	—	—	mA	
T <sub>FP</sub>	Pause Time After Flash	—	Control key	—	0.2	—	s	
T <sub>RP</sub>	Pause Time for One-key Redialing	—	One-key redialing	—	0.6	—	s	
T <sub>DB</sub>	Key-in Debounce Time	—	—	—	20	—	ms	

Symbol	Parameter	Test Conditions		Min.	Typ.	Max.	Unit
		V <sub>DD</sub>	Conditions				
T <sub>KTD</sub>	Keytone Delay	—	—	—	20	—	ms
T <sub>KTR</sub>	Keytone Release	—	—	—	20	—	ms
T <sub>BRK</sub>	Break Time for One-key Redialing	—	One-key redialing	—	2.2	—	s
F <sub>OSC</sub>	System Frequency	—	Crystal=3.5795MHz	3.5759	3.5795	3.5831	MHz

**Pulse Mode Electrical Characteristics**

 (F<sub>OSC</sub>=3.5795MHz, T<sub>a</sub>=25°C)

Symbol	Parameter	Test Conditions		Min.	Typ.	Max.	Unit
		V <sub>DD</sub>	Conditions				
I <sub>POH</sub>	$\overline{PO}$ Output Source Current	2.5V	V <sub>OH</sub> =2V	-0.2	—	—	mA
I <sub>POL</sub>	$\overline{PO}$ Output Sink Current	2.5V	V <sub>OL</sub> =0.5V	0.2	0.6	—	mA
PR	Pulse Rate	—	MODE pin is connected to VDD	—	10	—	pps
M/B	Make/Break Ratio	—	M/B=VSS	—	33:66	—	%
			M/B=VDD	—	40:60	—	
T <sub>PDP</sub>	Pre-digit-pause Time	—	M/B ratio=40:60	—	40	—	ms
			M/B ratio=33:66	—	33	—	
T <sub>IDP</sub>	Inter-digit-pause Time	—	Pulse rate=10pps	—	800	—	ms
T <sub>M</sub>	Pulse Make Duration	—	M/B ratio=33:66	—	33	—	ms
			M/B ratio=40:60	—	40	—	
T <sub>B</sub>	Pulse Break Duration	—	M/B ratio=33:66	—	66	—	ms
			M/B ratio=40:60	—	60	—	



**Tone Mode Electrical Characteristics**

 (F<sub>OSC</sub>=3.5795MHz, Ta=25°C)

Symbol	Parameter	Test Conditions		Min.	Typ.	Max.	Unit
		V <sub>DD</sub>	Conditions				
V <sub>TDC</sub>	DTMF Output DC Level	—	—	0.45V <sub>DD</sub>	—	0.7V <sub>DD</sub>	V
I <sub>TOL</sub>	DTMF Sink Current	2.5V	V <sub>DTMF</sub> =0.5V	0.1	—	—	mA
V <sub>TAC</sub>	DTMF Output AC Level	—	Row group, R <sub>L</sub> =5kΩ	0.12	0.155	0.18	V <sub>rms</sub>
R <sub>L</sub>	DTMF Output Load	2.5V	THD≤-23dB	5	—	—	kΩ
ACR	Column Pre-emphasis	2.5V	Row group=0dB	1	2	3	dB
THD	Tone Signal Distortion	2.5V	R <sub>L</sub> =5kΩ	—	-30	-23	dB
T <sub>TMIN</sub>	Minimum Tone Duration	—	Auto-redial	—	91	—	ms
T <sub>ITPM</sub>	Minimum Inter-tone Pause	—	Auto-redial	—	91	—	ms

$$\text{THD (Distortion) (dB)} = 20 \log \left( \frac{\sqrt{V_1^2 + V_2^2 + \dots + V_n^2}}{\sqrt{V_i^2 + V_h^2}} \right)$$

 V<sub>i</sub>, V<sub>h</sub>: Row group and column group signals

 V<sub>1</sub>, V<sub>2</sub>, ... V<sub>n</sub>: Harmonic signals (BW=300Hz~3500Hz)

**Functional Description**
**Keyboard matrix**

$\overline{C1}\sim\overline{C4}$  and  $\overline{R1}\sim\overline{R5}$  form a keyboard matrix. Together with a standard 5×5 keyboard, the keyboard matrix is used for dialing entries. The keyboard arrangement for the HT9245 series is shown in the **Keyboard Information**.

**Tone frequency**

Tone Name	Output Frequency (Hz)		% Error
	Specified	Actual	
$\overline{R1}$	697	699	+0.29%
$\overline{R2}$	770	766	-0.52%
$\overline{R3}$	852	847	-0.59%
$\overline{R4}$	941	948	+0.74%
$\overline{C1}$	1209	1215	+0.50%
$\overline{C2}$	1336	1332	-0.30%
$\overline{C3}$	1477	1472	-0.34%

Note: % Error does not contain the crystal frequency drift

**M/B ratio selection table**

M/B Pin	M/B Ratio (%)
VDD	40:60
VSS	33.3:66.6

**Flash function/time (duration) selection table**

Key-In	Flash Function	Flash Time (T <sub>F</sub> )
F1	Control	98ms
F2	Control	300ms
F3	Control	600ms

**Pause and P→T duration table**

T <sub>P</sub> (sec)	T <sub>P→T</sub> (sec)
3.1	3.1

**Pulse number table**

Keypad	Output Pulse Number
Digit Key	Normal N
1	1
2	2
3	3
4	4
5	5
6	6
7	7
8	8
9	9
0	10
*T	P→T
#	Ignored

**Tone duration and pause in redial function**

Parameter	Symbol	Typ.	Unit
Minimum Tone Duration	T <sub>TMIN</sub>	91	ms
Minimum Inter-tone Pause	T <sub>TTPM</sub>	91	ms
Cycle Time	T <sub>C</sub>	182	ms

**Hand-free function operation**

- Hand-free function execution  
When HFO is low, a falling edge triggers the  $\overline{\text{HFI}}$ , enabling the Hand-free function (HFO becomes high).
- Reset Hand-free function  
When HFO is high, the Hand-free function is enabled and can be reset by:
  - Off-hook
  - Applying a falling edge to  $\overline{\text{HFI}}$
  - Changing the HDO pin from low to high
- Hand-free function table

Current State			Input			Next State	
HKS	HFO	HDO	HDI	HFI	HKS	HFO	HDO
H	L	X	H	H	An	L	An
H	L	X	H	↓	An	H	L
H	H	X	H	↓	An	L	An
H	X	L	H	H	L	L	L
L	L	X	H	H	An	L	An
L	L	X	H	↓	An	H	L
L	H	L	H	↓	An	L	An
L	X	X	H	H	H	An	An
X	X	L	↓	H	An	L	H

H: Logic HIGH    X: Don't care    ↑: Rising edge  
L: Logic LOW    An: Unchanged    ↓: Falling edge

**Hold-line function operation**

- **Hold-line function execution**  
When HDO is low, a falling edge triggers  $\overline{\text{HDI}}$ , enabling the Hold-line function (HDO becomes high). The  $\overline{\text{XMUTE}}$  remains low when HDO is high.
- **Reset Hold-line function**  
When HDO is high, the Hold-line function is enabled and can be reset by:
  - Off-hook
  - Applying a falling edge to  $\overline{\text{HDI}}$
  - Changing the HFO pin from low to high

• **Hold-line function table**

Current State			Input			Next State	
$\overline{\text{HKS}}$	HDO	HFO	$\overline{\text{HFI}}$	$\overline{\text{HDI}}$	$\overline{\text{HKS}}$	HDO	HFO
H	L	X	H	H	An	L	An
H	L	X	H	$\downarrow$	An	H	L
H	H	L	H	$\downarrow$	An	L	An
H	X	X	H	H	L	L	L
L	L	X	H	H	An	L	An
L	L	X	H	$\downarrow$	An	H	L
L	H	L	H	$\downarrow$	An	L	An
L	X	X	H	H	H	An	An
X	X	L	$\downarrow$	H	An	L	H

H: Logic HIGH    X: Don't care     $\uparrow$ : Rising edge  
 L: Logic LOW    An: Unchanged     $\downarrow$ : Falling edge

**DOUT BCD code**

When dialing, the corresponding 4-bit BCD codes are serially presented on DOUT from MSB to LSB. The data of DOUT is valid at the falling edge of the CLOCK pin.

The following table lists the BCD codes corresponding to the keyboard input.

Key-In	BCD Code	Key-In	BCD Code
1	0001	8	1000
2	0010	9	1001
3	0011	0	1010
4	0100	*/T	1101
5	0101	#	1100
6	0110	F	1011
7	0111	P	1110

**Key definition**

- 0,1,2,3,4,5,6,7,8,9 keys  
These are dialing number input keys for both the pulse mode and the tone mode operations.
- \*/T  
This key executes the P→T function and waits a  $T_{P \rightarrow T}$  duration in the pulse mode. On the other hand, the \*/T key executes the \* function in the tone mode.
- #  
This is a dialing signal key for the tone mode only, no response in the pulse mode.
- SA  
Pressing this key can save the preceding dialing telephone numbers. The saved number is redialed if it is pressed again. SA will also redial the saved number if it is the first key pressed at the off-hook state. During the dialing signal transmission, the SA key is inhibited.
- P  
Pause key. The execution of this key pauses the output for the  $T_P$  duration.  $T_P$  is 3.1 secs.

- F1~F3

The flash keys are control keys. Pressing the F1~F3 keys will force the PO pin to be "low" for the  $T_F$  duration and is then followed by  $T_{FP}$  (sec).

Key-In	Flash Time
F1	98ms
F2	300ms
F3	600ms

- R

Redial key. Executes redialing as well as one-key redial function.

- MT

The MUTE and  $\overline{XMUTE}$  pin outputs are toggled when the MT key is pressed.

- ST

Store key. The execution of this key actuates the store memory function with (or without) dialing output. During the dialing signal transmission, the ST key is inhibited.

- EM1~EM3

One-touch memory dialing key. For speed-calling convenience, they provide memory dialing in either pulse or tone mode.

- A

Auto key. When this key is pressed before pressing any of the digital keys (0~9) it executes the two-touch memory dialing function.

- CD

Call disconnect key. When pressed, the chip will reset to its initial state.

**Keyboard operation**

The following operations are described under an on-off-hook or on-hook condition with the hand-free active condition.

- Normal dialing

- Pulse mode

- (a) without \*/T

Keyboard input: D1 D2 ... Dn

Dialing output: D1 D2 ... Dn

RM: D1 D2 ... Dn

SAM: Unchanged

- (b) with \*/T

Keyboard input: D1 D2 ... Dn \*/T Dn+1 ... Dm

Dialing output: D1 D2 ... Dn  $T_{P \rightarrow T}$  Dn+1 ... Dm  
Pulse Tone

RM: D1 D2 ... Dn \*/T Dn+1 ... Dm

SAM: Unchanged

- Tone mode

- (a) without \*/T

Keyboard input: D1 D2 ... Dn

Dialing output: D1 D2 ... Dn

RM: D1 D2 ... Dn

SAM: Unchanged

- (b) with \*/T

Keyboard input: D1 D2 ... Dn \*/T Dn+1 ... Dm

Dialing output: D1 D2 ... Dn \* Dn+1 ... Dm

RM: D1 D2 ... Dn \* Dn+1 ... Dm

SAM: Unchanged

Note: The maximum capacity of the RM memory is 32 digits. When more than 32 digits are entered, the signal is transmitted but the redial function is inhibited.

- Redial

- Pulse mode

- (a) without \*/T

RM content: D1 D2 ... Dn

Keyboard input: R

Dialing output: D1 D2 ... Dn

RM: Unchanged

SAM: Unchanged

- (b) with \*/T

RM content: D1 D2 ... Dn \*/T Dn+1 ... Dm

Keyboard input: R

Dialing output: D1 D2 ... Dn  $T_{P \rightarrow T}$  Dn+1 ... Dm  
Pulse Tone

RM: Unchanged

SAM: Unchanged

- Tone mode

- (a) without \*/T

RM content: D1 D2 ... Dn

Keyboard input: R

Dialing output: D1 D2 ... Dn

RM: Unchanged

SAM: Unchanged

- (b) with \*/T

RM content: D1 D2 ... Dn \*/T Dn+1 ... Dm

Keyboard input: R

Dialing output: D1 D2 ... Dn \* Dn+1 ... Dm

RM: Unchanged

SAM: Unchanged

• One-key redial

– Pulse mode

(a) without \*/T

Keyboard input:  $\boxed{D1} \boxed{D2} \dots \boxed{Dn} \boxed{R}$   
 Dialing output: D1 D2 ... Dn T<sub>BRK</sub> T<sub>RP</sub>  
                   D1 D2 ... Dn  
 RM: D1 D2 ... Dn  
 SAM: Unchanged

(b) with \*/T

Keyboard input:  $\boxed{D1} \boxed{D2} \dots \boxed{Dn} \boxed{*/T} \boxed{Dn+1} \dots$   
                    $\boxed{Dm} \boxed{R}$   
 Dialing output:  $\underbrace{D1 \ D2 \dots Dn}_{\text{Pulse}} \ T_{P \rightarrow T} \ \underbrace{Dn+1 \dots Dm}_{\text{Tone}}$   
                   T<sub>BRK</sub> T<sub>RP</sub>  $\underbrace{D1 \ D2 \dots Dn}_{\text{Pulse}} \ T_{P \rightarrow T}$   
                    $\underbrace{Dn+1 \dots Dm}_{\text{Tone}}$   
 RM: D1 D2 ... Dn \*/T Dn+1 ... Dm  
 SAM: Unchanged

– Tone mode

(a) without \*/T

Keyboard input:  $\boxed{D1} \boxed{D2} \dots \boxed{Dn} \boxed{R}$   
 Dialing output: D1 D2 ... Dn T<sub>BRK</sub> T<sub>RP</sub> D1 D2  
                   ... Dn  
 RM: D1 D2 ... Dn  
 SAM: Unchanged

(b) with \*/T

Keyboard input:  $\boxed{D1} \boxed{D2} \dots \boxed{Dn} \boxed{*/T} \boxed{Dn+1} \dots$   
                    $\boxed{Dm} \boxed{R}$   
 Dialing output: D1 D2 ... Dn \* Dn+1 ... Dm  
                   T<sub>BRK</sub> T<sub>RP</sub> D1 D2 ... Dn \* Dn+1  
                   ... Dm  
 RM: D1 D2 ... Dn \* Dn+1 ... Dm  
 SAM: Unchanged

Note: If the dialing number exceeds 32 digits, redialing is inhibited and  $\overline{PO}=VDD$

• SA copy

– Pulse mode

(a) without \*/T

Keyboard input:  $\boxed{D1} \boxed{D2} \dots \boxed{Dn} \boxed{R}$   
 Dialing output: D1 D2 ... Dn  
 RM: D1 D2 ... Dn  
 SAM: D1 D2 ... Dn

(b) with \*/T

Keyboard input:  $\boxed{D1} \boxed{D2} \dots \boxed{Dn} \boxed{*/T} \boxed{Dn+1} \dots$   
                    $\boxed{Dm} \boxed{SA}$   
 Dialing output:  $\underbrace{D1 \ D2 \dots Dn}_{\text{Pulse}} \ T_{P \rightarrow T} \ \underbrace{Dn+1 \dots Dm}_{\text{Tone}}$   
 RM: D1 D2 ... Dn \*/T Dn+1 ... Dm  
 SAM: D1 D2 ... Dn \*/T Dn+1 ... Dm

– Tone mode

(a) without \*/T

Keyboard input:  $\boxed{D1} \boxed{D2} \dots \boxed{Dn} \boxed{R}$   
 Dialing output: D1 D2 ... Dn  
 RM: D1 D2 ... Dn  
 SAM: D1 D2 ... Dn

(b) with \*/T

Keyboard input:  $\boxed{D1} \boxed{D2} \dots \boxed{Dn} \boxed{*/T} \boxed{Dn+1} \dots$   
                    $\boxed{Dm} \boxed{SA}$   
 Dialing output: D1 D2 ... Dn \* Dn+1 ... Dm  
 RM: D1 D2 ... Dn \* Dn+1 ... Dm  
 SAM: D1 D2 ... Dn \* Dn+1 ... Dm

Note: The maximum capacity of the RM memory is 32 digits. When more than 32 digits plus the "SA" key are entered, the SAVE function will not be executed, and all the existing data in the save memory will not be changed.

• SA dialing

– Pulse mode

(a) without \*/T

SAM content: D1 D2 ... Dn  
 Keyboard input: **SA**  
 Dialing output: D1 D2 ... Dn  
 RM: Unchanged  
 SAM: Unchanged

(b) with \*/T

SAM content: D1 D2 ... Dn \*/T Dn+1 ... Dm  
 Keyboard input: **SA**  
 Dialing output:  $\underbrace{D1 D2 \dots Dn}_{\text{Pulse}} \text{ TP} \rightarrow \text{T} \underbrace{Dn+1 \dots Dm}_{\text{Tone}}$   
 RM: Unchanged  
 SAM: Unchanged

– Tone mode

(a) without \*/T

SAM content: D1 D2 ... Dn  
 Keyboard input: **SA**  
 Dialing output: D1 D2 ... Dn  
 RM: Unchanged  
 SAM: Unchanged

(b) with \*/T

SAM content: D1 D2 ... Dn \* Dn+1 ... Dm  
 Keyboard input: **SA**  
 Dialing output: D1 D2 ... Dn \* Dn+1 ... Dm  
 RM: Unchanged  
 SAM: Unchanged

• Memory store

– One-touch memory store

(a) without dialing output

Keyboard input: **ST** **D1** **D2** ... **Dn** **ST** **EMa**  
 Dialing output:  
 EMa: D1 D2 ... Dn  
 RM: D1 D2 ... Dn  
 SAM: Unchanged

(b) with dialing output

Keyboard input: **D1** **D2** ... **Dn** **ST** **ST** **EMa**  
 Dialing output: D1 D2 ... Dn  
 EMa: D1 D2 ... Dn  
 RM: D1 D2 ... Dn  
 SAM: Unchanged

– Two-touch memory store

(a) without dialing output

Keyboard input: **ST** **D1** **D2** ... **Dn** **ST** **a**  
 Dialing output:  
 Ma: D1 D2 ... Dn  
 RM: D1 D2 ... Dn  
 SAM: Unchanged

(b) with dialing output

Keyboard input: **D1** **D2** ... **Dn** **ST** **ST** **a**  
 Dialing output: D1 D2 ... Dn  
 Ma: D1 D2 ... Dn  
 RM: D1 D2 ... Dn  
 SAM: Unchanged

Note: If the dialing number exceeds 32 digits, the memory store is inhibited.

However, if the dialing number is not more than 32 digits the memory will store a max. of 16 digits.

EMa=EM1~EM3, Ma=M0~M9, a=0~9

• Memory dialing

– One-touch memory dialing (EM1~EM3)

EMa content: D1 D2 ... Dn  
 Keyboard input: **EMa**  
 Dialing output: D1 D2 ... Dn  
 EMa: Unchanged  
 RM: D1 D2 ... Dn  
 SAM: Unchanged

– Two-touch memory dialing (M0~M9)

Ma content: D1 D2 ... Dn  
 Keyboard input: **A** **a**  
 Dialing output: D1 D2 ... Dn  
 Ma: Unchanged  
 RM: D1 D2 ... Dn  
 SAM: Unchanged

Note: EMa=EM1~EM3, Ma=M0~M9, a=0~9

- Chain dialing

EM1 content: D1 D2 ... Dn

EM2 content: Dn+1 ... Dm

M1 content: Dm+1 ... DI

M2 content: DI+1 ... Dk

Keyboard input: D1 D2 D3 A 1 A 2 EM1 EM2

Dialing output: D1 D2 D3 Dm+1 ... DI DI+1 ... Dk D1 D2 ... Dn Dn+1 ... Dm

EM1/EM2/M1/M2: Unchanged

RM: D1 D2 D3 Dm+1 ... DI DI+1 ... Dk D1 D2 ... Dn Dn+1 ... Dm

SAM: Unchanged

Note: The maximum capacity of the RM memory is 32 digits. When the dialing number exceeds 32 digits, redialing is inhibited and  $\overline{PO}=VDD$

- Flash

Keyboard input: D1 D2 ... Dn F Dn+1 ... Dm

Dialing output: D1 D2 ... Dn T<sub>F</sub> T<sub>FP</sub> Dn+1 ... Dm

RM: Dn+1 ... Dm

SAM: Unchanged

Note: T<sub>F</sub>: break a flash time

F: any one of the F1~F3

- Pause

Keyboard input: D1 D2 ... Dn P Dn+1 ... Dm

Dialing output: D1 D2 ... Dn T<sub>P</sub> Dn+1 ... Dm

RM: D1 D2 ... Dn P Dn+1 ... Dm

SAM: Unchanged

- Note:

RM: Redial memory

SAM: Save dialing memory

D1 D2 ... Dn: 0~9

Dn+1 ... Dm: 0~9, \*, #

Dm+1 ... DI: 0~9, \*, #

DI+1 ... Dk: 0~9, \*, #



### Timing Diagrams

#### Normal dialing

##### • Pulse mode

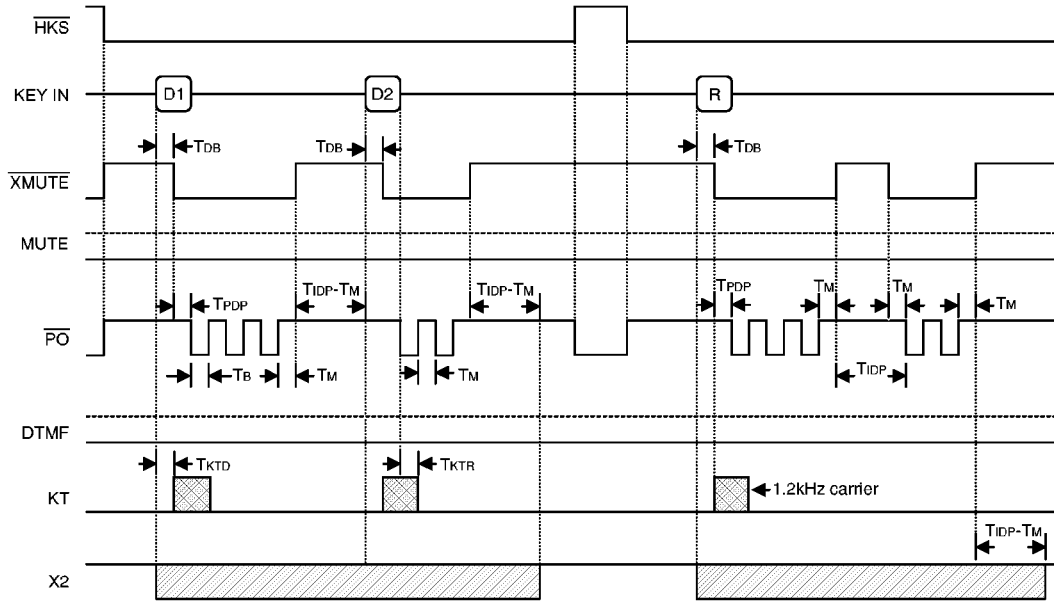

##### • Tone mode

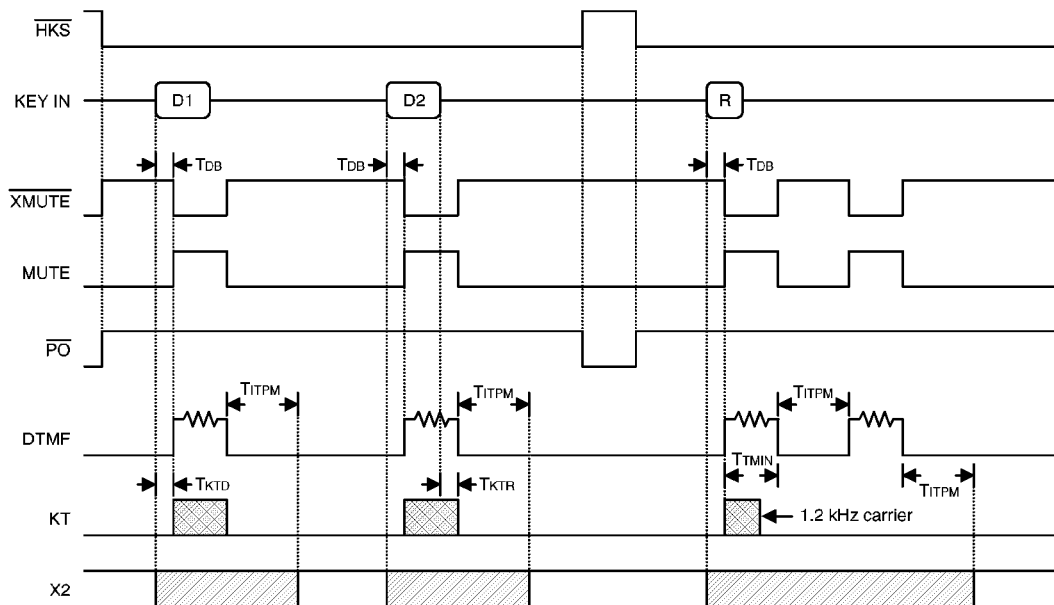

Dialing with pause key

• Pulse mode

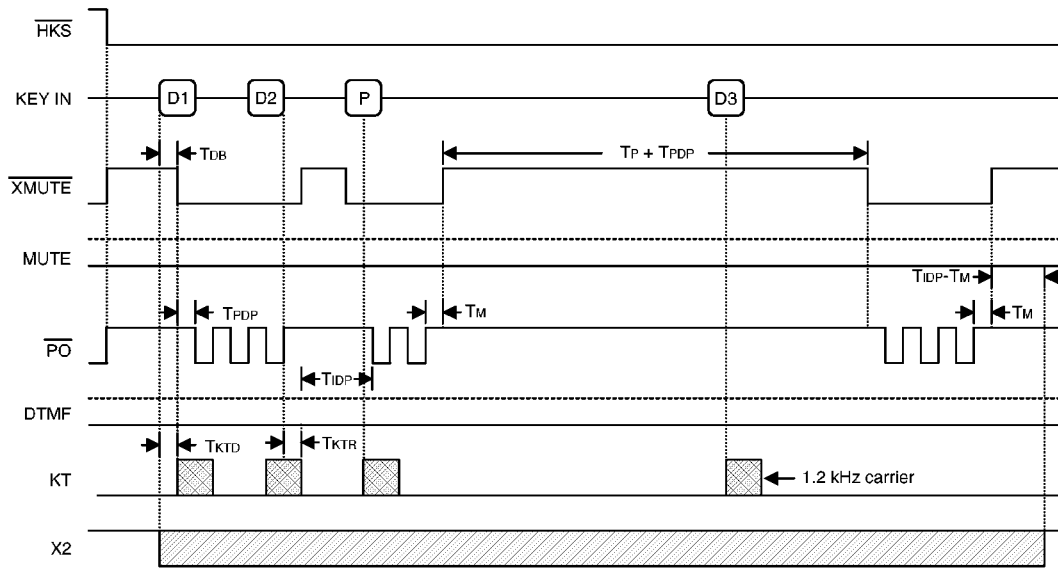

• Tone mode

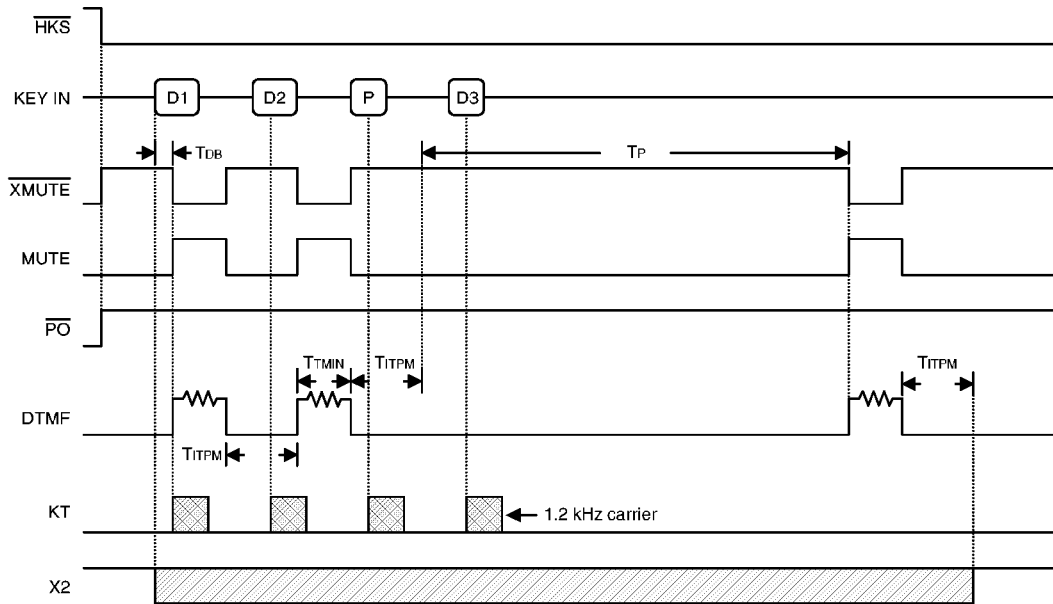

**Flash key operation**

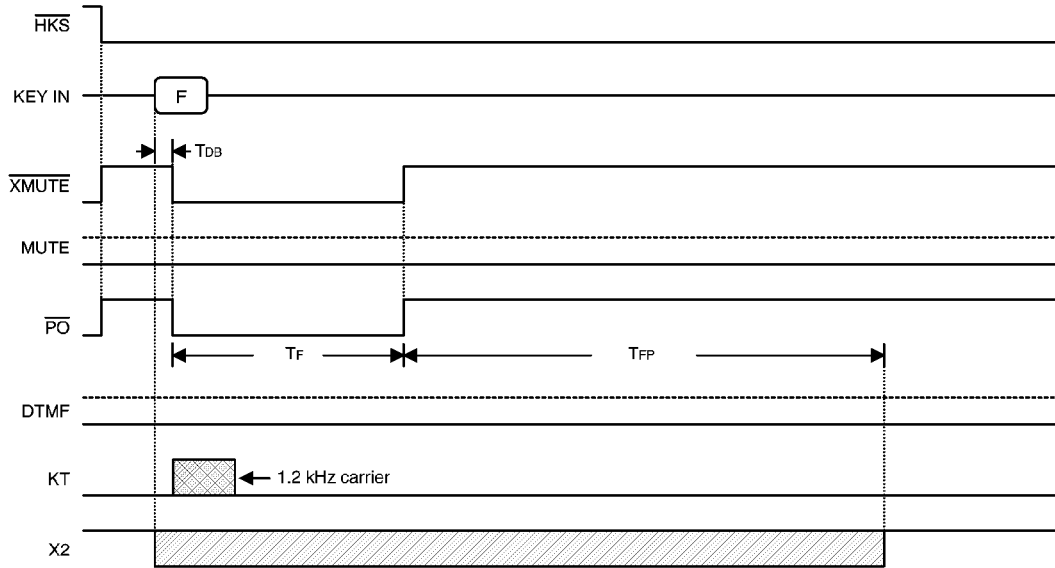

**Pulse→Tone operation**

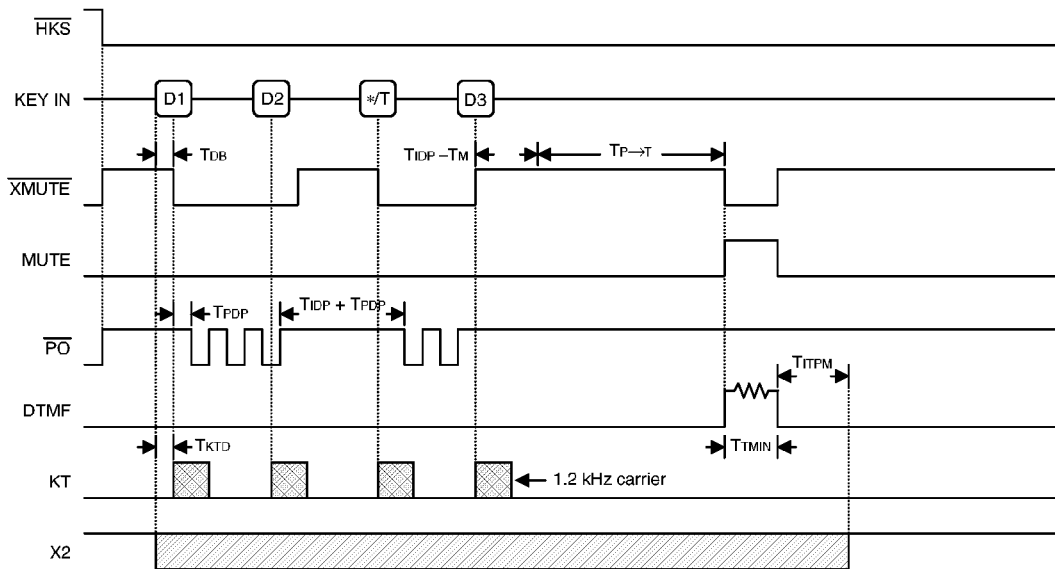

**One key redial operation**

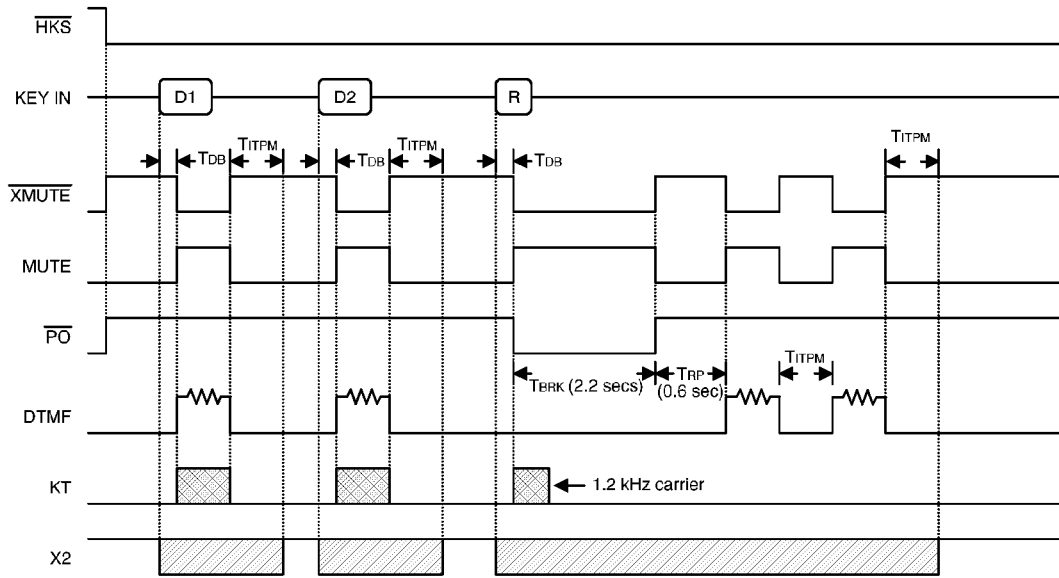

**Call disconnect (CD) & MUTE (MT) operation**

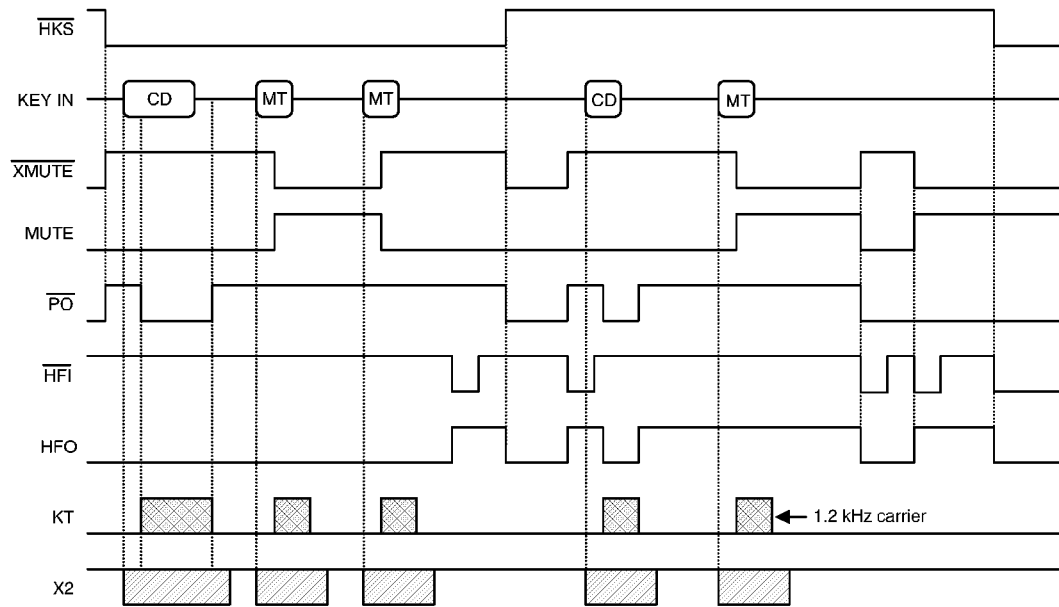

**CLOCK & DOUT operation**

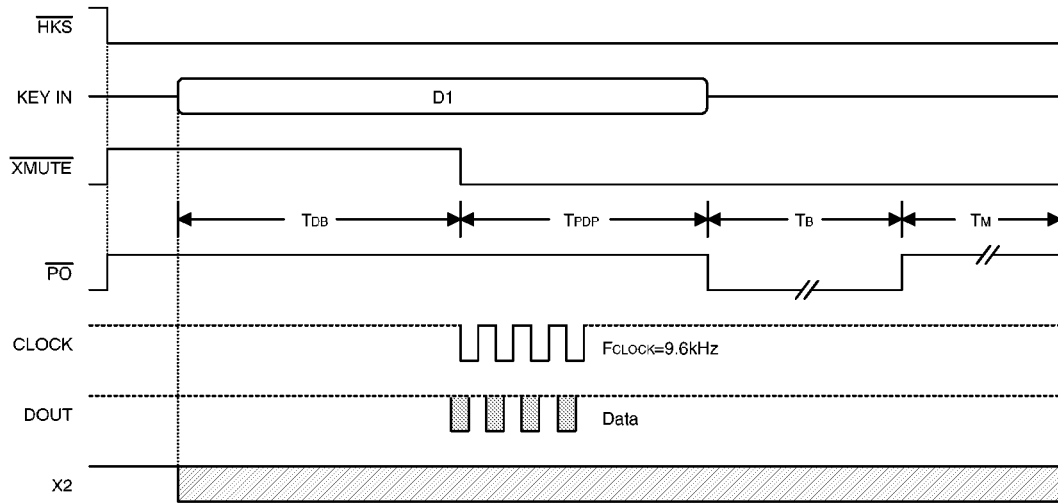

Note: D1=D3=3  
D2=2

**Application Circuits**

Application circuit 1

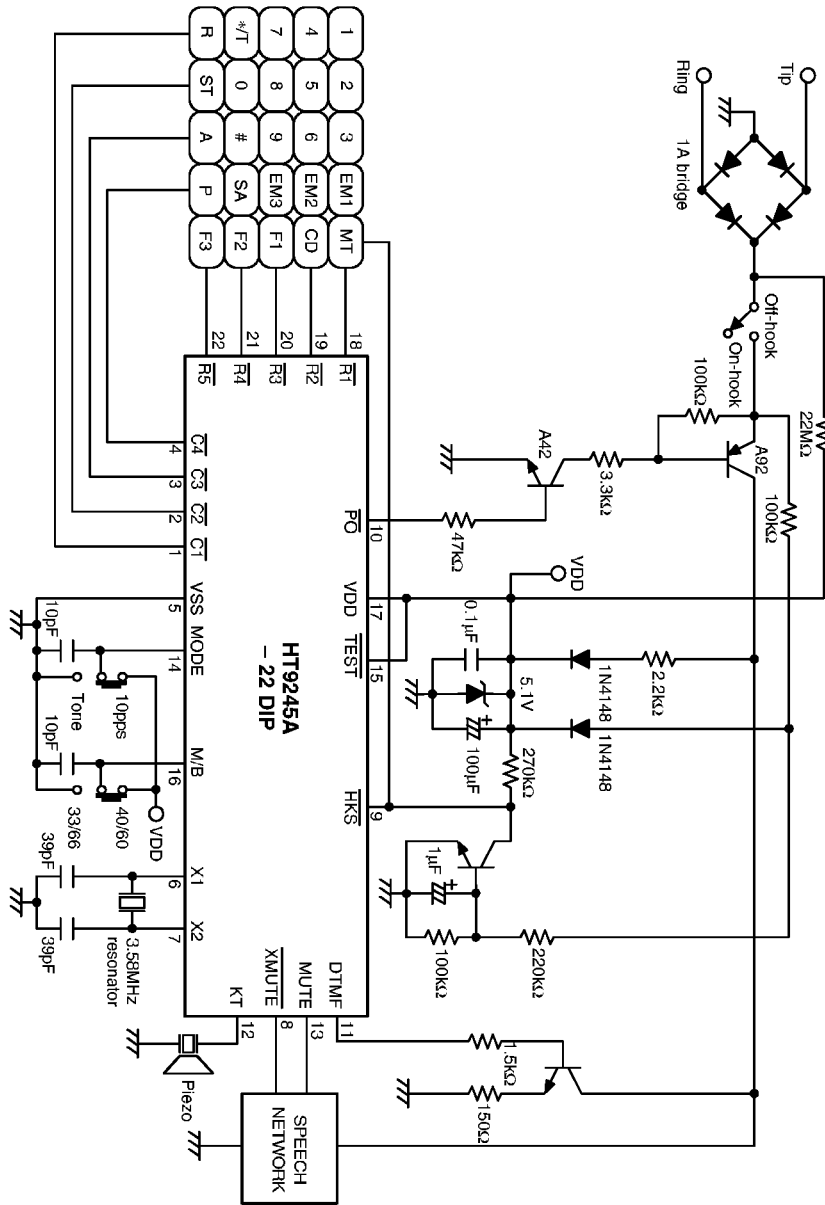

\* Unspecified transistors are of 8050 type

Application circuit 2

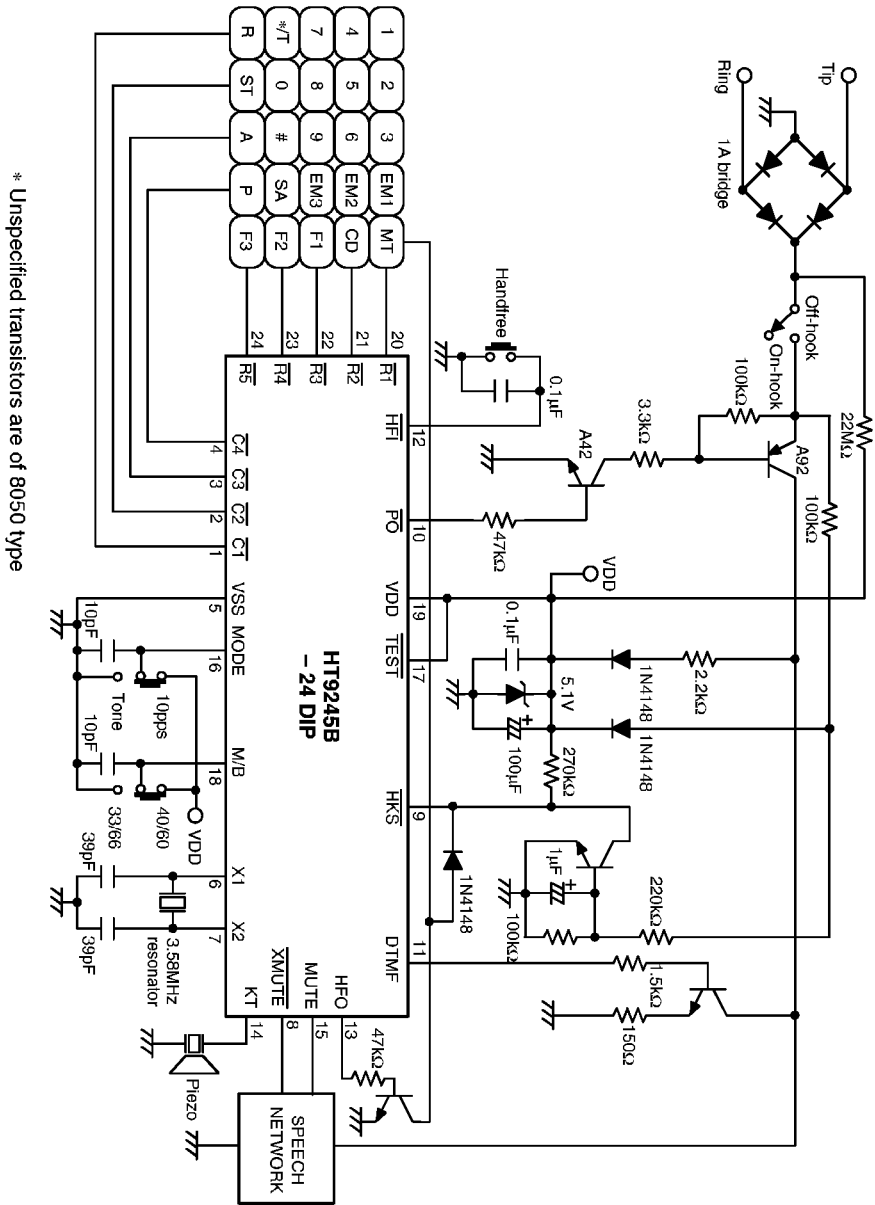

Application circuit 3

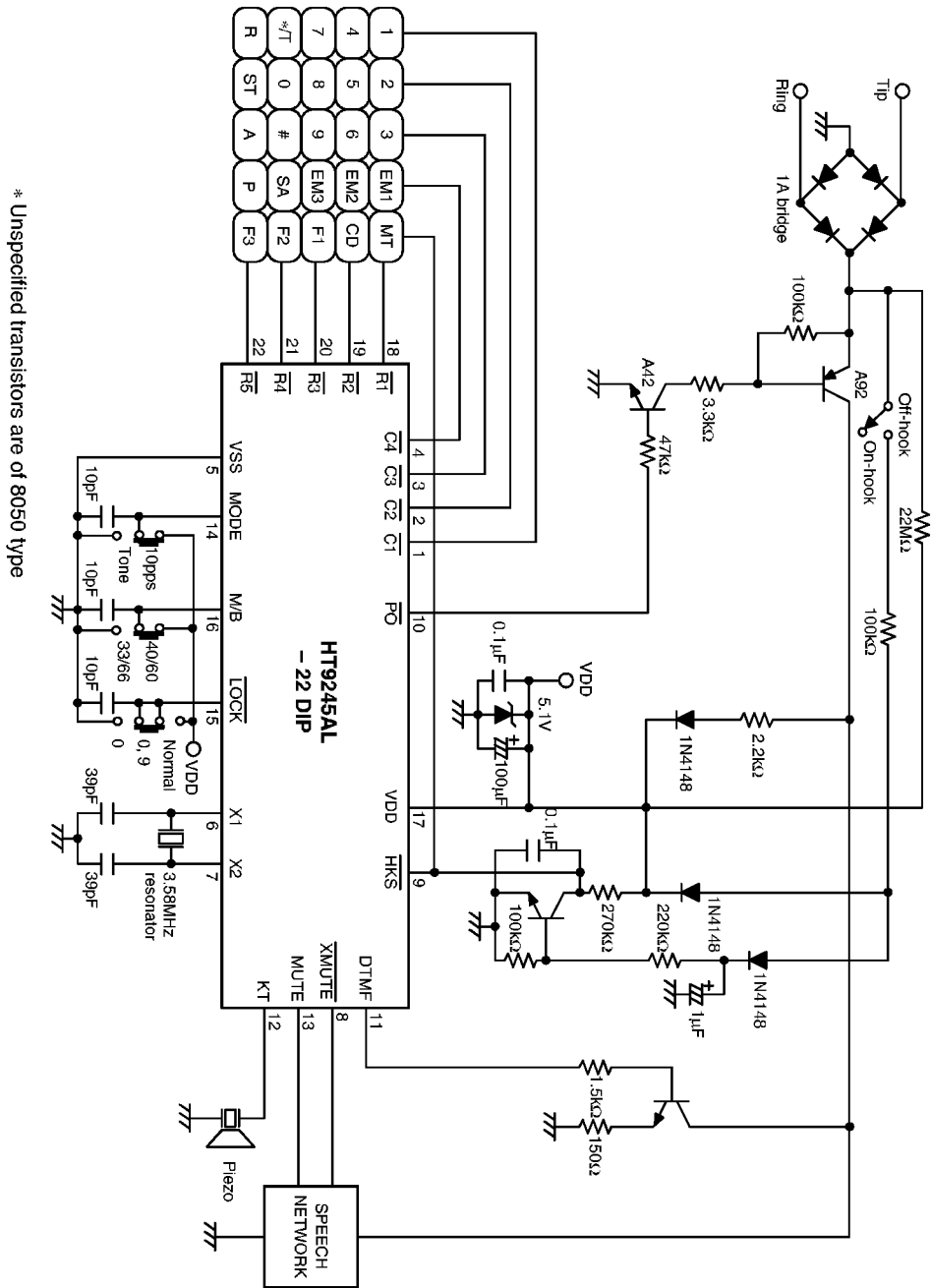

\* Unspecified transistors are of 8050 type



Application circuit 4

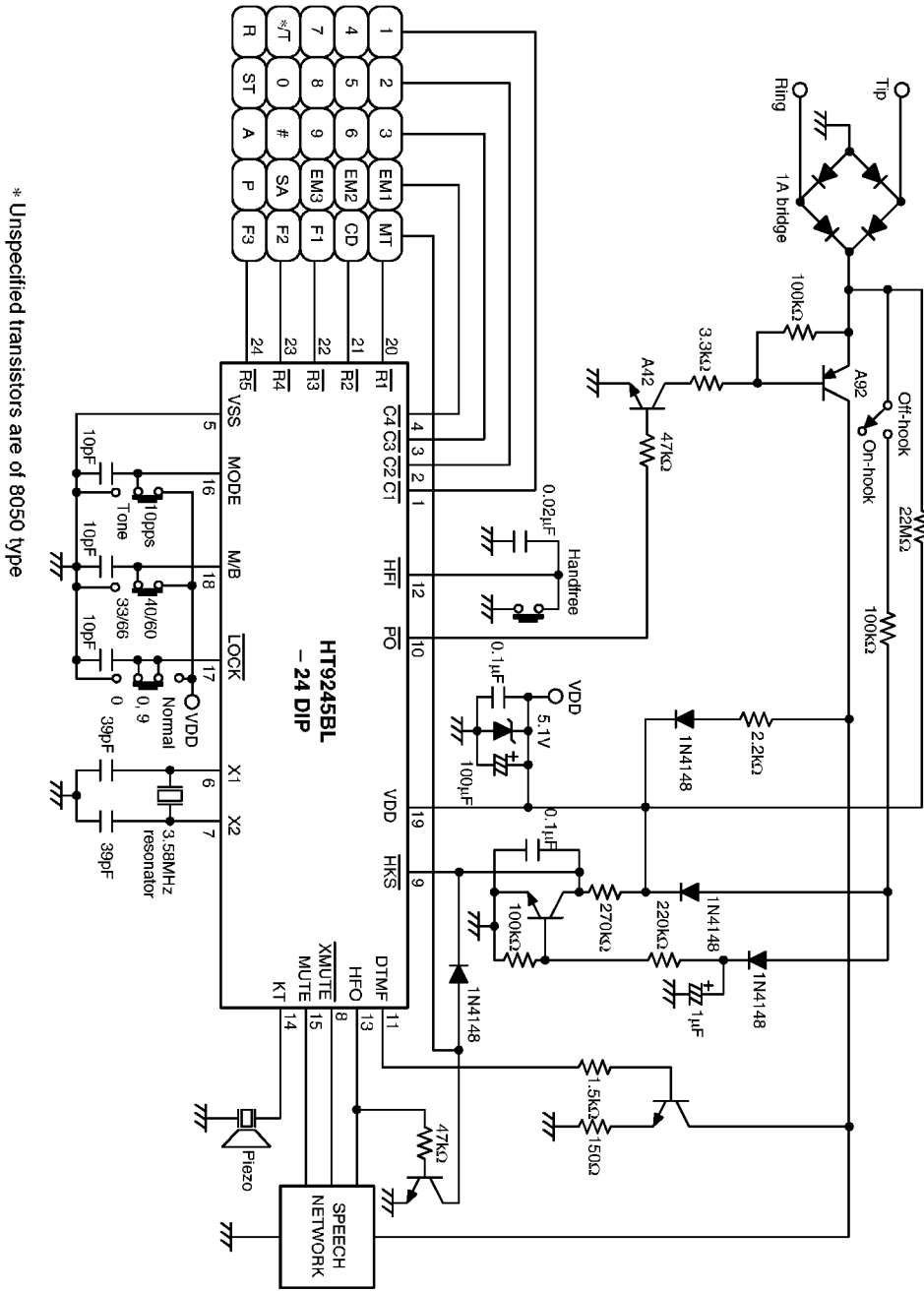

\* Unspecified transistors are of 8050 type

Application circuit 5

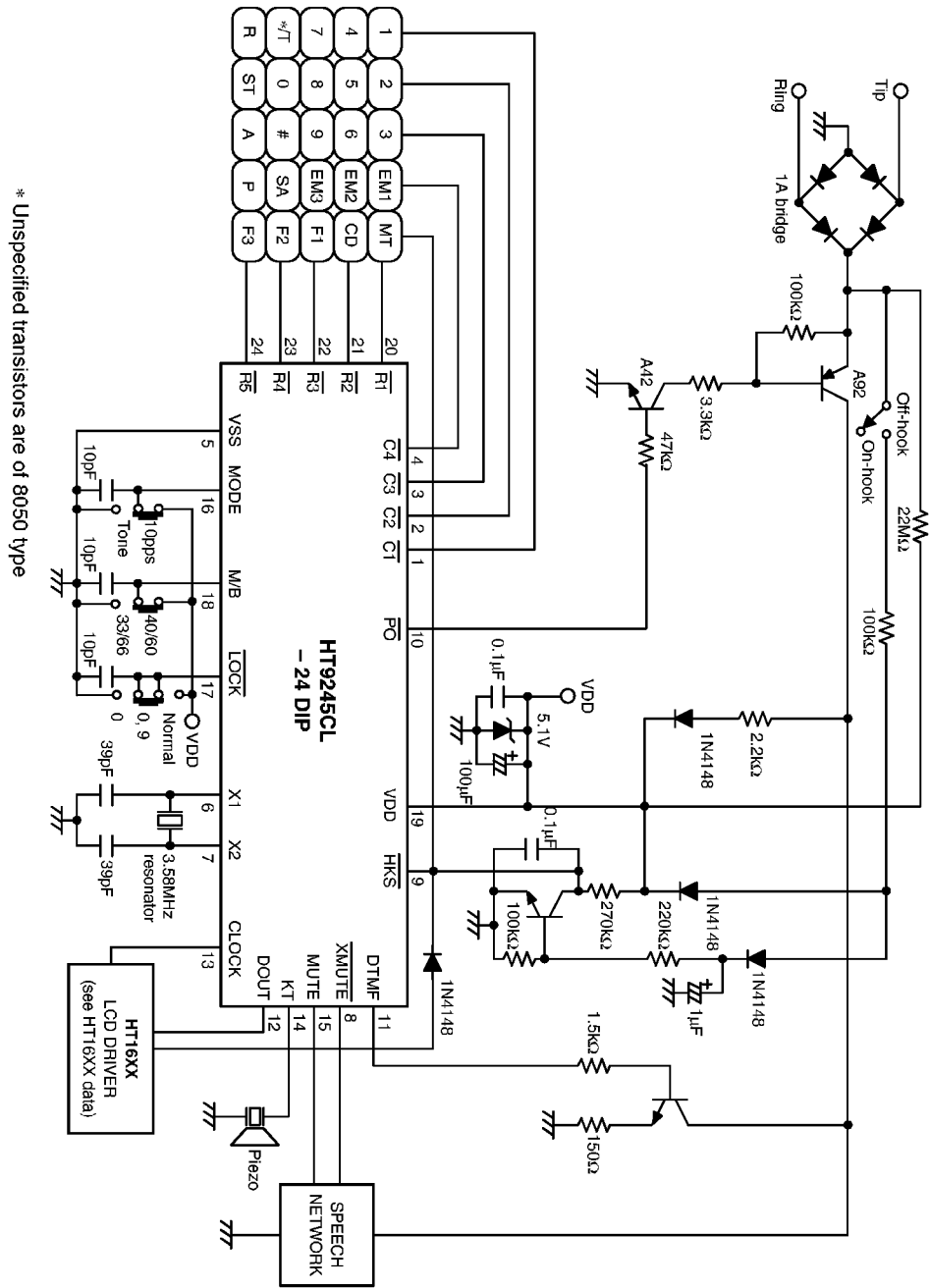

Application circuit 6

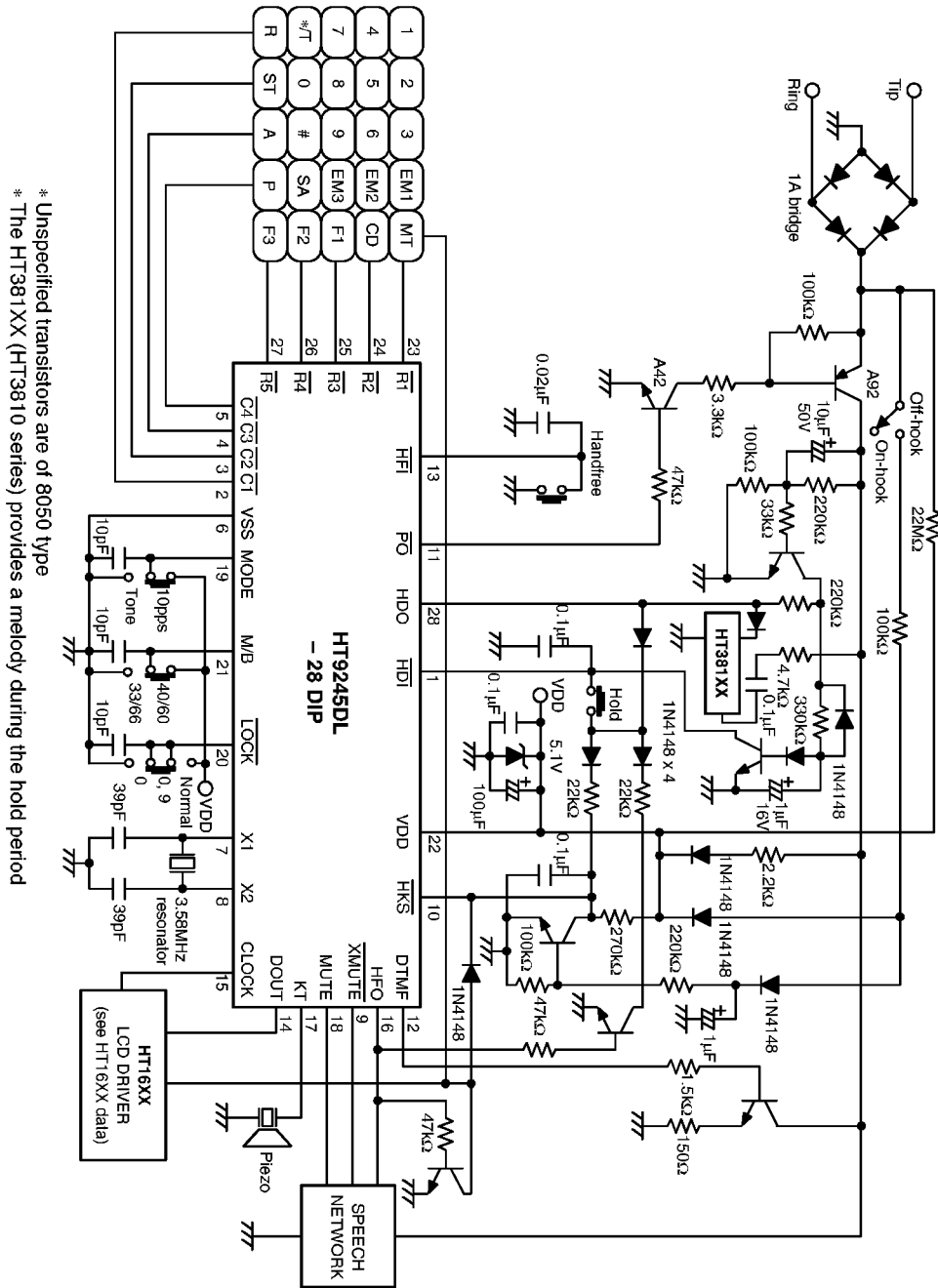

\* Unspecified transistors are of 8050 type  
 \* The HT381XX (HT3810 series) provides a melody during the hold period