

Designation system:

- CN = **C**hip **N**ot molded
 2220 = Dimensions of the device **22x20** (length x width in 1/100 inch)
 S...B = **S**pecial tolerance **B** of the varistor voltage
 14 = Max. RMS operating voltage
 AUTO = Suited for **AUTO**motive application
 G = Taped version, blister tape, 7" reel (1500 pcs/reel)

Part Dimensions:

(All dimensions in mm)

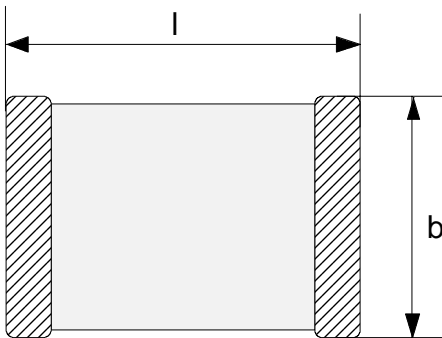

$$\begin{aligned}
 l &= 5,7 \pm 0,4 \\
 b &= 5,0 \pm 0,4 \\
 s &= 1,3 \text{ max.} \\
 k &= 0,25 - 1,0
 \end{aligned}$$

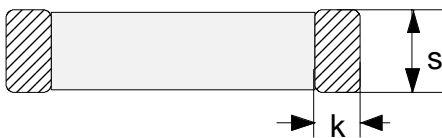

V-I-Characteristic

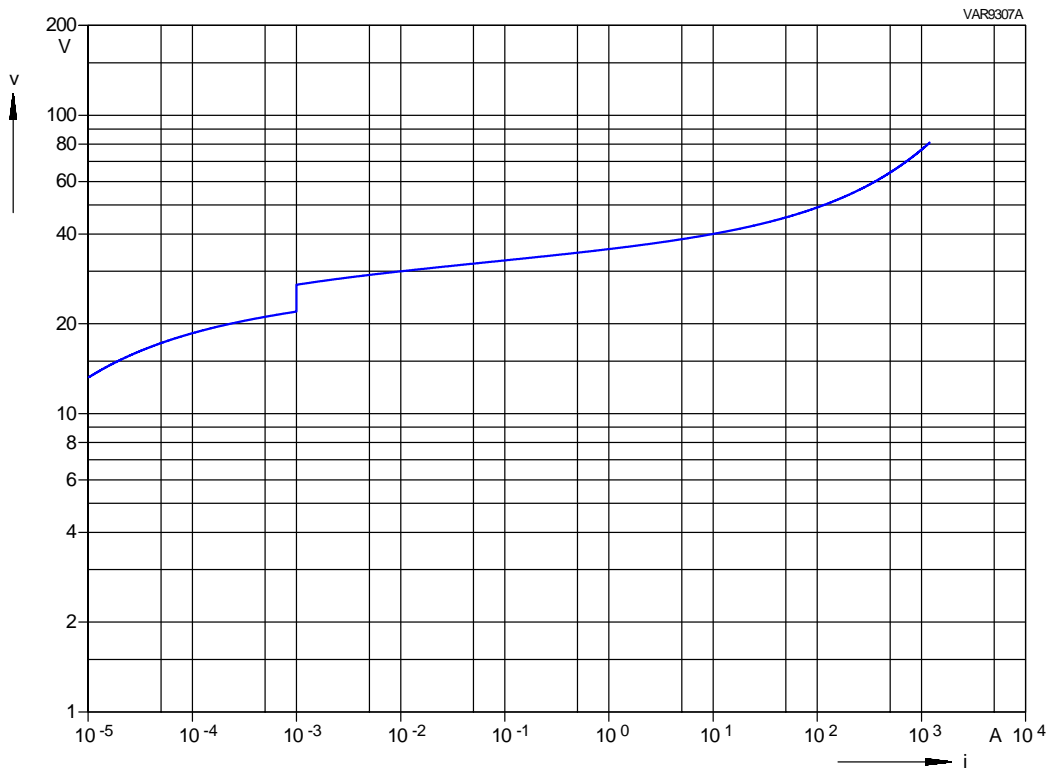

Derating Field

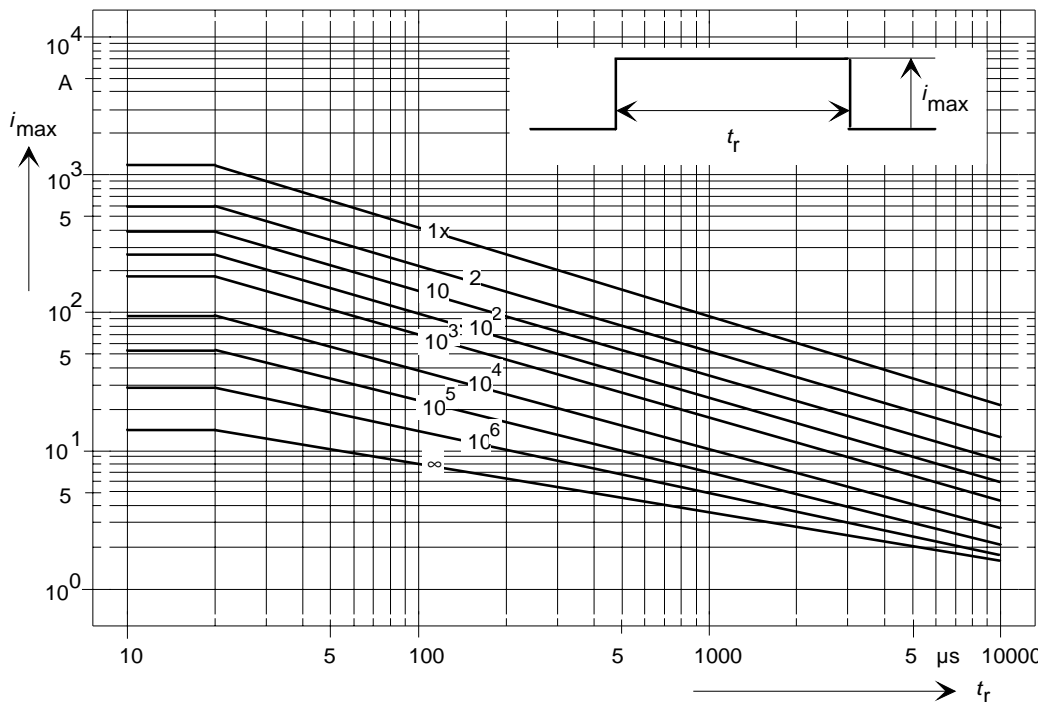



Electrical Data

Max. operating voltage

RMS voltage

$V_{eff} = 14 V$

DC voltage

$V_{DC} = 16 V$

Varistor voltage (@ 1 mA)

$V_v = 22 - 27 V$

Max. clamping voltage (@ 10 A)

$V_C = 40 V$

Max. average power dissipation

$P_{max} = 30 mW$

Max. surge current (8/20 μs)

$\hat{I}_{max} = 1 \times 1200 A$

Max. energy absorption (2 ms)

$E_{max} = 1 \times 5.8 J$

Load Dump

$E_{max} = 10 \times 12 J$

Jump Start

24.5 V, 5 min.

Capacitance (@ 1kHz, 1 V), typically

9.5 nF

Response time

< 0.5 ns

Operating temperature

-55 ... +125 °C

Storage temperature (mounted parts)

-55 ... +150 °C

Termination material

Ag/Pd

Max. current, energy, operating voltage and average power dissipation depending on ambient temperature

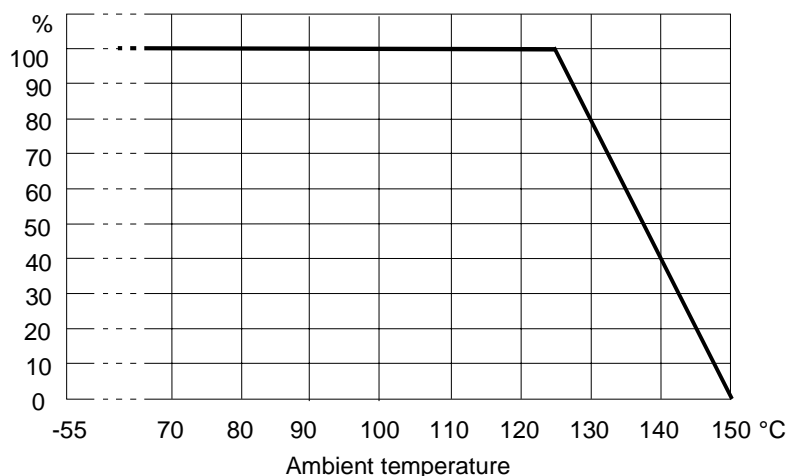

Recommended solder pad layout

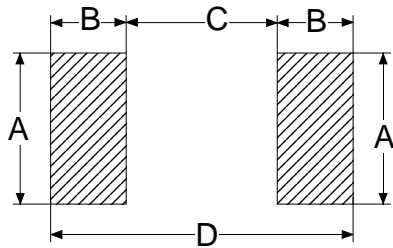

A = 5,5 mm
 B = 1,5 mm
 C = 4,2 mm
 D = 7,2 mm

Recommended soldering temperature profiles

Wave soldering

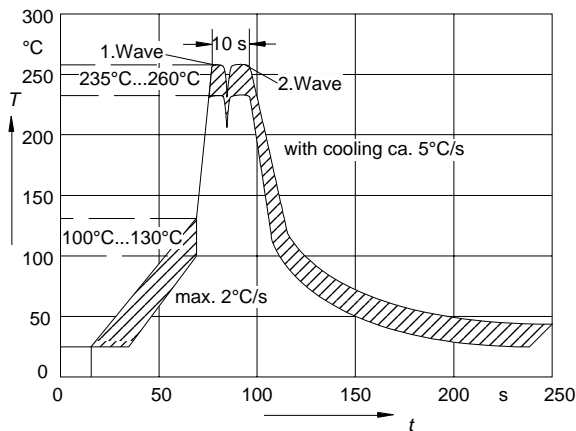

IR reflow soldering

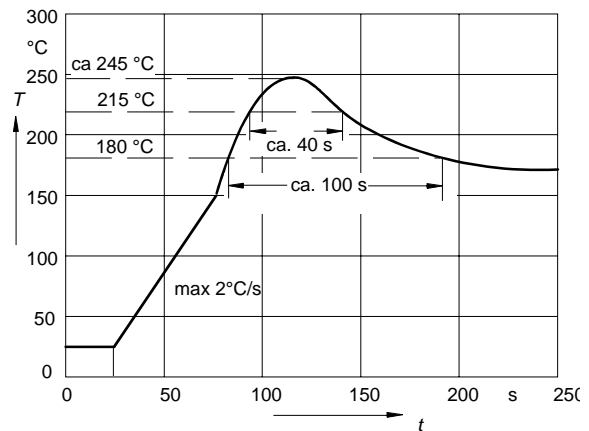

The components should be soldered within 6 months after delivery from EPCOS. The parts are to be left in the original packing in order to avoid any soldering problems caused by oxidized terminals.

Storage temperature: -25 to 45°C

Relative humidity: <75% annual average, <95% on max. 30 days in a year.

The usage of mild, non activated fluxes for soldering is recommended, as well as a proper cleaning of the PCB.

Taping and Packaging:

Taping: Tape and reel packing according to IEC 60286-3

Tape material: Blister

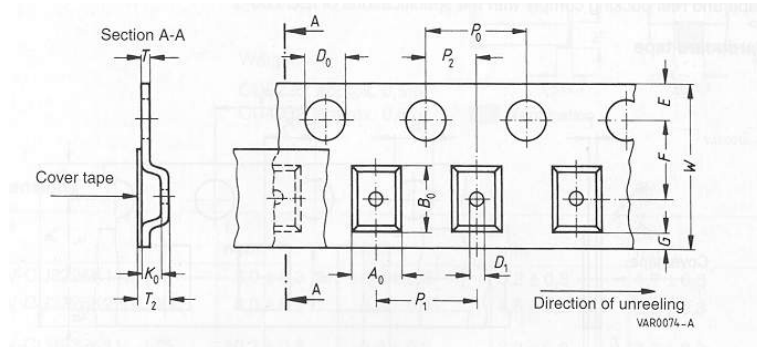

Dimensions and tolerances:

Definition	Symbol	Dimension [mm]	Tolerance [mm]
Compartment width	A_0	5.1	± 0.2
Compartment length	B_0	6.0	± 0.2
Compartment height	K_0	1.3	max.
Sprocket hole diameter	D_0	1.5	$+0.1 / -0$
Compartment hole diameter	D_1	1.5	min.
Sprocket hole pitch	P_0	4.0	± 0.1 ¹⁾
Distance center hole to center compartment	P_2	2.0	± 0.05
Pitch of the component compartments	P_1	8.0	± 0.1
Tape width	W	12.0	± 0.3
Distance edge to center of hole	E	1.75	± 0.1
Distance center hole to center compartment	F	5.5	± 0.05
Distance compartment to edge	G	0.75	min.
Overall thickness	T_2	2.5	max.
Thickness tape	T	0.3	max.

¹⁾ $\leq \pm 0.2$ mm over any 10 pitches

Package: 12 mm tape:

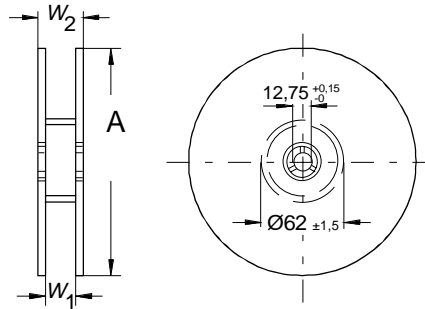
Data Sheet
Packing:
Packing material: Plastic

Reel Dimensions:

Definition	Symbol	Dimension [mm]	Tolerance [mm]
Reel diameter	A	180	-2
Reel width (inside)	W_1	12.4	+1.5 /-0
Reel width (outside)	W_2	18.4	max.

Packing unit: 1500 pcs / reel

© EPCOS AG 2002. Reproduction, publication and dissemination of this data sheet, enclosures hereto and the information contained therein without EPCOS' prior express consent is prohibited.

Purchase orders are subject to the General Conditions for the Supply of Products and Services of the Electrical and Electronics Industry recommended by the ZVEI (German Electrical and Electronic Manufacturers' Association), unless otherwise agreed.

ISSUE DATE	09.08.02	ISSUE	d	PUBLISHER	KB VS PE	PAGE	6/6
------------	----------	-------	---	-----------	----------	------	-----