

Honeywell

TotalPlant Solution (TPS) System

TPS System Overview

TP01100

R100

11/98

TotalPlant

Notices and Trademarks

Copyright 1998 by Honeywell Inc.

November 25, 1998

While this information is presented in good faith and believed to be accurate, Honeywell disclaims the implied warranties of merchantability and fitness for a particular purpose and makes no express warranties except as may be stated in its written agreement with and for its customers.

In no event is Honeywell liable to anyone for any indirect, special or consequential damages. The information and specifications in this document are subject to change without notice.

Honeywell, **TotalPlant**, and TDC 3000 are U.S. registered trademarks of Honeywell Inc.

Other brand or product names are trademarks of their respective owners.

Honeywell Inc.
Industrial Automation and Control
Automation College
2820 West Kelton Lane
Phoenix, AZ 85053-3028
1 (800) 852-3211

About This Document

References

Honeywell Documents

The following list identifies TPS Honeywell documents that may be sources of reference for the material discussed in this publication. These publications are also sent on CD-ROM

Document Title	Doc. ID
System Overview	SW70-500

Contacts

The following lists identify important contacts within Honeywell.

World Wide Web

Honeywell provides internet access to several of Honeywell World Wide Web sites. The following lists those sites of interest to our industrial customers.

Organization	WWW Address (URL)
Honeywell Inc.	http://www.honeywell.COM
Honeywell Industrial Automation and Control	http://www.iac.honeywell.COM

Sales and Service

Location	Organization	Phone Number
United States and Canada	Honeywell IAC Phoenix, Arizona	1-800-343-0228 Sales
		1-800-525-7439 Service
Outside United States and Canada	Your Honeywell Local Affiliate	If Local Affiliate is unknown, ask your corporate region for the Local Affiliate's name and phone number.

About This Document

Corporate Regions

Global Location	Organization	Phone Number
Asia Pacific	Honeywell Asia Pacific Inc. Hong Kong	(852) 8298298
Europe	Honeywell PACE Brussels, Belgium	[32-2] 728-2111
Latin America	Honeywell Inc. Sunrise, Florida U.S.A.	(305) 364-2355

Contents

INTRODUCTION.....	9
Overview.....	9
Functional Overview	10
Scope	10
TPS System Components (Control)	11
PRODUCT STRUCTURE	19
TPS System Driving Forces.....	19
TPS System Characteristics.....	19
TPS System Composition.....	19
TPS System Concepts	20
TPS System Component Connectivity	22
Node Roles in TPS System	22
TPS System Configurations	24
Product Packaging	26
PRODUCT OVERVIEW	27
Hardware	27
LCNP4.....	27
TPS System Ready Consoles	28
Intel-Based Platforms	28
Global User Station (GUS).....	28
Base System	29
Multiple Displays.....	29
GUS Display Server (local TPN Data).....	29
HCI Named Data Access.....	29
GUS Utilizing IOMaps.....	29
GUS Standard Displays.....	30
SafeView	30
Reusable Components	30
TPSDDE.....	30
Uniformance Desktop	31
Process Trend	31
TDC Viewer	31

Contents

Scheduler	32
Visual PHD.....	32
Example Excel Spreadsheet	32
Interactive Query.....	33
Dynamic Query (DQ) and Microsoft Query (MQ).....	33
History Browser.....	33
Process History Database (PHD).....	33
Multiple Data Types Supported.....	33
Tag Configuration.....	34
Class Tag Configuration.....	34
Data Retrieval Independent of Data Collection	34
Time Weighted Data Reductions	34
Automatic Engineering Unit Conversions.....	34
Virtual Calculations	34
Conditional Data Search and Retrieval	35
System Capacity	35
Exception Condition Interfaces	35
Automated Backup.....	35
Data Compression	35
HCI PHD Server.....	36
TPN Event Journal Collection and Storage.....	36
Application Program Execution	36
NT Client Applications.....	37
CL Server	37
Application I/O.....	38
Event Annunciation and Journal Entries	39
System Management	40
Performance and Network Management.....	40
Security Management	41
System Configuration.....	41
Build Environment.....	42
TPS Builder	42
PHD Configuration	42
Display Translator	43
Display Builder	43
SafeView Editor.....	43
HCI Client Toolkit	43
HCI Server Toolkit.....	44
Distributed Communication (HCI/OPC)	44
Value Added Functions and Robustness	45
TPS System Naming Structure	45

SECURITY	47
Security Approach	47
NT Domain	47
TPS Domain	47
User ID Verification.....	47
Access Rights.....	48
Security Objects	48
Permissions	48
Proxy Files.....	48
User Groups	48
Operators	49
Interactive User Interface	49
TPSDDE and File Transfer.....	49
PHD	50
Security Objects and Access Control Mechanisms	51
RELATED PRODUCTS AND APPLICATIONS	53
Network and Integration Services	53
User Alert	53
Equipment Health Management (EHM)	53
Advanced Control Applications	54
Profit Suite.....	54
Oil Movements and Storage.....	55
TotalPlant Batch	55
GLOSSARY	57
Acronyms and Abbreviations	57
Terminology	59

Tables and Figures

Table 1	TPS System Security Objects and Access Control Mechanisms	51
Figure 1	TPS System	10
Figure 2	TPS Hardware Components	12
Figure 3	TPS Software Components	13
Figure 4	Node Roles in TPS System.....	22
Figure 5	Minimum TPS System Configuration	24
Figure 6	Typical TPS System Configuration	25
Figure 7	Large TPS System Configuration	26
Figure 8	Communication Interface Structure.....	44

Introduction

Overview

The TPS (**TotalPlant** Solution) System Overview document provides a high level description of Honeywell IAC's open automation system intended for use on projects from small to very large. The TPS system is the evolution of the TDC 3000^x system (now called TPS Network) and includes all the capabilities of that system, as well as many new capabilities. The TPS components, such as the human interface and application platform, are described here, as well as the unified and consistent approach for accessing data and managing system resources.

Functional Overview

Scope

The **TotalPlant** Solution (TPS) system is Honeywell’s open plant automation system. It includes our robust, secure distributed control capabilities, as well as advanced applications like multivariable control, batch control, and optimization, plant-wide history, and information management capabilities in one unified system. The diagram below illustrates this approach.

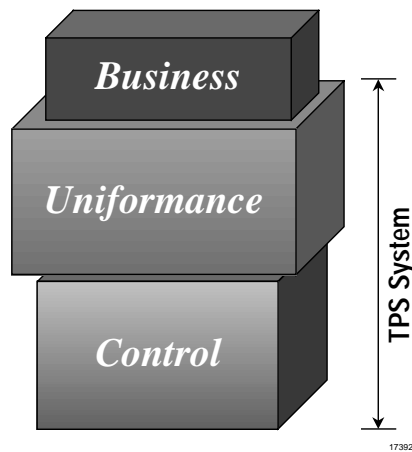

Figure 1 TPS System

This document focuses on the components contained within the “Control” portion of the TPS system. These control components comprise the automation platform upon which the information and application software is supported. They include the field devices, human interfaces, application platform support, as well as the system infrastructure that “glues” the system together. Some of the components include:

- Field Measurement Control
 - Transmitters
 - Analyzers
 - Sensors
- Regulatory Control
 - High Performance Process Manager
 - Application Module/Application Nodes

- Global User Station/Universal Station
- History Module/Process History Database
- Fail Safe Controller

This document does **not** cover the information management applications, advanced control applications or Honeywell services, nor does it dwell on TPS system components fully documented in other publications, such as TPS Network or Field Instruments. A description of several Unifformance products can be found in the section entitled Related Products and Applications. While not all Unifformance products are represented there, all are well integrated with TPS Control to complete the TPS system.

TPS System Components (Control)

The TPS system is designed to meet the needs of large systems while being scaleable to relatively small systems. TPS system key features include the following:

- Openness
- Smart field devices
- State-of-the-art human interface
- Advanced engineering tools
- Real-time database and plant-wide historian
- Open application environment
- Proven robust and secure control environment
- Open interface to enterprise management applications

TPS system's unifying infrastructure pulls these features together into a complete system.

Introduction – Functional Overview

A hardware overview of the TPS system major components is pictured below.

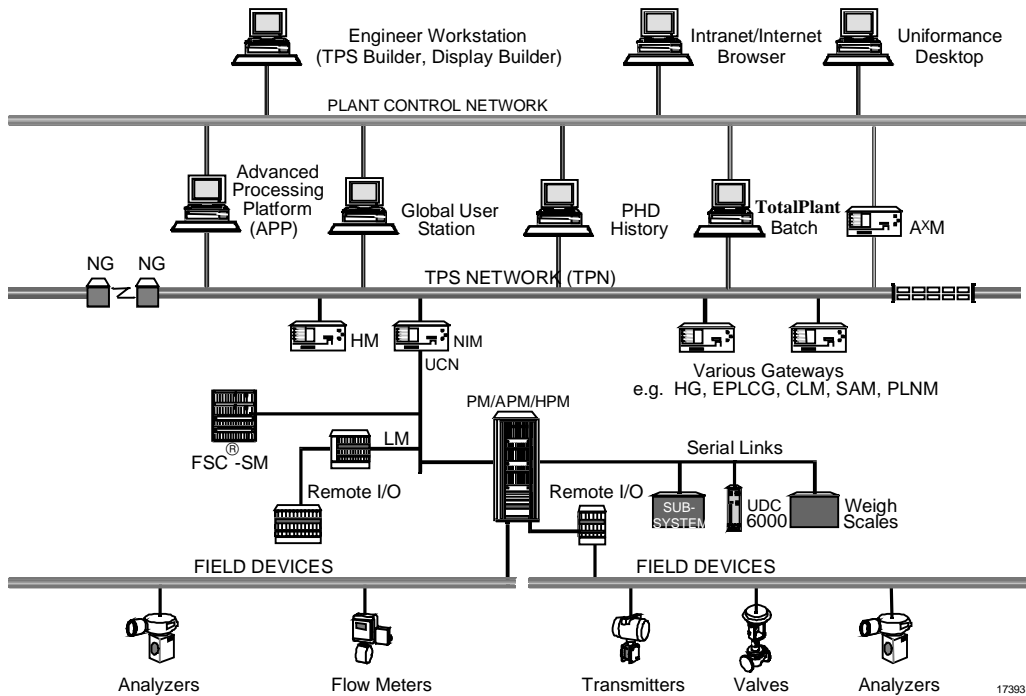

Figure 2 TPS Hardware Components

The thrust of the TPS system is an integrated set of components.

- Global User Station (GUS)
- Process History Database (PHD) historian and real-time database
- Application nodes including the Application Processing Platform (APP)
- TPS Builder
- TPS Network (TPN)
- Smart field devices
- Unifying TPS Infrastructure

The software architecture is pictured below, and is followed by a description of each of the major components.

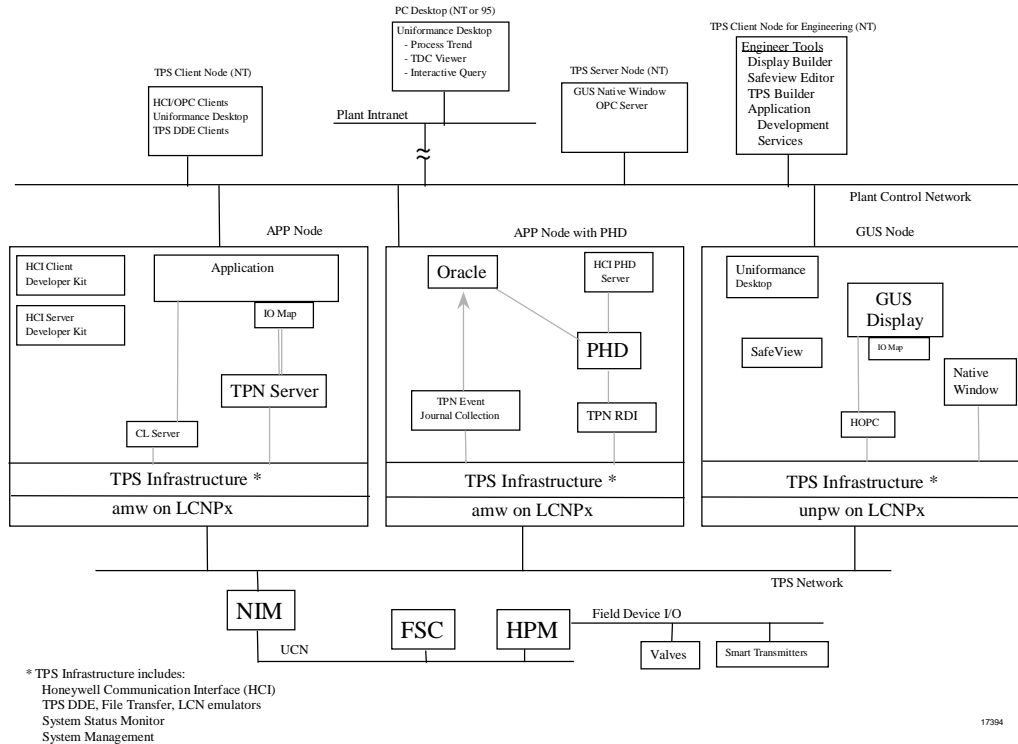

Figure 3 TPS Software Components

TPS Node

A TPS node is a commercial Intel-based workstation running Microsoft’s Windows NT operating system. It contains TPS system software and belongs to a TPS Domain. It has a connection to the Plant Control Network (PCN) and can optionally have a connection to the TPS Network (TPN). The functions that a TPS node performs depend on the combination of TPS system software loaded (e.g., operator interaction or application processing). A TPS node is defined as any of the following.

- GUS
- APP
- Client or Server Node

Global User Station (GUS)

GUS is a TPS node that has a connection to the TPS Network (TPN) through an LCNP or LCNP4 card and runs a US (unpw) personality. It is packaged in a Console or Deskside configuration. It is a state-of-the-art human interface and consists of a Native Window, Display Runtime, and SafeView. The Native Window provides all original TPN Universal Station operating and engineering displays in a window on the Global User Station. The Display Runtime component executes GUS displays built by the Display Builder or translated from TPN schematics by the Display Translator. SafeView is a window manager that allows a user to define where types of windows can appear, move to, resize or overlap other windows. SafeView can be configured to ensure that critical windows are never hidden.

GUS is intended for use by operators and engineers to monitor and control the process, Honeywell TPS components, and applications. GUS provides historical trending from the TPN History Module or from PHD. GUS displays can also get named data from a PHD data source or another TPN using HCI named data access rather than the local connection to the TPN, known as HOPC. This helps keep the local TPN loading to a minimum.

Application Processing Platform (APP)

The APP is a TPS node that has a connection to the TPS Network through an LCNP4 card and runs either an AM or AMw personality. It is packaged in either a deskside or desktop configuration. The APP is a state-of-the-art application platform for integrating advanced control or information management applications. It can communicate directly with an existing TPS Network.

The APP contains the TPS system Infrastructure component for communicating to TPN and to HCI/OPC client and server applications in TPS Client and TPS Server nodes. It also contains other functions such as TPS Status Display, TPS Configuration, File Transfer and TPSDDE. The CL Server leverages existing Application Module (AM) applications by allowing them to initiate applications that reside in the Windows NT environment.

Applications may also be built using the IOMap interface to connect to HCI/OPC servers. This interface provides the ability to write generic applications through tag name aliases and to gather data from multiple data sources in a single call.

TPS Client or Server Node

A TPS client or server node is an off the shelf workstation purchased outside of Honeywell and is connected to the PCN. It does not have a TPS Network connection, but can host TPS client applications, or TPS server applications, or both. Client applications that can run on the APP can also run here, although they need to connect to

an APP to get TPN data. Server applications would include any HCI/OPC server of data (see TPS System Infrastructure for more on this). In addition, it can host Engineering software such as GUS Display Builder or TPS Builder.

TPS Builder

TPS Builder is a graphical engineering tool for building control strategies and configuring process control data on a TPS system.

It includes the following.

- Easy-to-use graphical user-interface
- Provision for building and use of templates
- Simultaneous creation of the control drawing while creating the control strategy
- Ability to share data and work with other applications
- Other advanced capabilities

TPS Builder supports the following capabilities.

- Configuration
- Documentation
- Database reporting
- Control Language (CL) programming support
- Control strategy drawing

Process History Database

PHD is a plant-wide, high-performance historian. It can collect data from any TPS data source including the TPS Network and non-TPS systems. PHD provides data imaging of these systems, including calculated and user-defined auxiliary values. PHD also provides access to non-TPS devices for any TPS component or application. PHD allows the supervisory portion of TPS to be independent of the data source.

Application data may also be contained within PHD and can be used by applications to share information. For example, GUS can display or alter application data and PHD can historize it.

PHD is currently configured by its own builder in TPS; however, over time its configuration will be integrated within the TPS Builder.

Desktop Tools

The desktop tools are referred to as the Uniformance Desktop. These tools are used by engineers and management to do the following:

- Monitor the process
- Troubleshoot
- Perform analysis and reporting functions

The desktop provides a trend/analysis tool for the desktop, Excel-based report generator, scheduler, and graphic viewer. These tools are designed to work with PHD data and other data sources.

TPS System Infrastructure

The system infrastructure pulls the system together. It provides secure communication between the major TPS components, and allows these components to be physically distributed across TPS nodes. The data access function of the infrastructure provides access to TPS Network data for TPS components and applications. The following are the main components of the infrastructure.

- **OPC** – OLE for Process Control Interfaces
- **HCI** - Honeywell Communications Interfaces, utilizing Microsoft's DCOM technology and OPC
- **HCI Client and Server Toolkits**
- **HCI TPN Server** - Data access server for TPN data
- **TPSDDE** – TPN data read capability through Microsoft's Dynamic Data Exchange mechanism
- **File Transfer** - capability to transfer files between the HM and the Windows NT file system
- **System Status Monitor** - monitors status of TPS nodes and components
- **System Management** - startup, shutdown, backup, restore, security, configuration, and replication

The communication infrastructure provides a set of interfaces that includes the data access mechanisms as defined by the OPC standards committee, as well as enhancements such as prioritized requests, timed requests and status information. The **HCI TPN Server** provides the link between applications and TPS Network data. It is an OPC server that also recognizes HCI value added interfaces. Thus, it can serve data to applications that use OPC-only and those that use HCI/OPC interfaces.

The HCI client toolkit enables development and testing of HCI/OPC client applications. The HCI server toolkit includes a generic server that significantly decreases the effort of developing an HCI server.

System Management helps to ease certain tasks that are required due to the networked environment of the TPS system. This includes a mechanism to retrieve, view, or be notified of system problems as well as a facility for viewing and/or modifying configuration information or system component status.

To access non-TPS device interfaces, the recommended approach is to develop HCI/OPC servers. However, these devices could be also accessed through the implementation of a PHD RDI (Realtime Data Interface). Then applications could access this data using the HCI PHD Server.

TPS Network (TPN)

The TPS Network remains a key component of TPS, and provides a full-function control environment that is proven to be robust and flexible. Existing TPS Network customers can maintain their capital and intellectual investment, while taking advantage of advanced features available with TPS. The TPS Network consists of the following.

- **TPS Network (TPN)**, formerly referred to as the LCN, is a redundant and robust communication network with a set of nodes that are directly connected to it. The nodes include the following.
 - Process network interface nodes (such as NIM for the UCN)
 - History collection nodes (HM)
 - Human interface nodes (GUS, US)
 - Application modules (AM) for implementing advanced control algorithms
 - In addition, data point alarming and monitoring of the control room equipment is performed here
- **Data Hiway** The Data Hiway is the classic process network originally introduced in 1975 and still a valid data source to anywhere within the TPS system. It includes many hiway-based devices such as the basic controller and the multifunction controller that provide data acquisition and control functions.
- **Universal Control Network (UCN)** The UCN is a high-speed, high-security process network. It does the following.
 - Allows for peer-to-peer communication
 - Provides platforms for implementing sophisticated control schemes (HPM), and platforms that perform safety-related functions (FSC)

- Provides the I/O interface to field devices

For more information on the TPS Network, refer to the *System Overview* (SW70-500).

Field Devices

Process data like pressure, temperature and flow, is collected and transmitted by field instruments to process-connected controllers. TPS system includes a complete portfolio of smart transmitters that span a wide performance range and can provide the basis for process control in any system. Smartline products have set the standard for quality, reliability, accuracy, and can be digitally integrated to the Honeywell automation system.

These products and solutions are divided into the following three areas.

- **Analytical Instruments** - proprietary sensor technology applicable to a broad portfolio of liquid and gas measurements, as well as particle and components measurements.
- **Control Products** - process control instrumentation for meeting the needs of a variety of industries. These include the LeaderLine family of controllers, programmers, and recorders. The LeaderLine Controllers are used to control temperature, level, pressure, furnace atmosphere, and relative humidity. TPS system integration capability provides remote control functions with operator functions fully accessible at the Global User Station.
- **Field Instruments** - robust process measurement solutions for pressure, temperature, level, and flow using Honeywell's Smartline field instruments. These instruments provide bidirectional digital communication between transmitter and controller or Field Communicator and can be digitally integrated with the TPS system automation systems to minimize project implementation, downtime, and maintenance costs. A range of output communication options is available, which include standard 4-20 mA, Digital Enhanced (DE), HART, and Foundation Fieldbus.

Product Structure

TPS System Driving Forces

The TPS system integrates TPS components into an open, unified, coherent system.

- A **common component distribution and naming philosophy** that allows the components to inter-operate and to be managed, without reliance on a single name server
- A **single operating environment** providing state-of-the art display and workspace techniques for presentation and operation of all components and applications on them
- Security mechanisms that leverage NT's built-in security structures to allow plant-wide access while protecting the integrity of the control system
- Data integration policies that allow defining and sharing of data among executing applications, history, and human interface, without dependence on the TPS Network
- An intercommunication infrastructure that provides access to this data through common mechanisms that provide the performance and integrity necessary, while leveraging industry standards for lower costs and improved plant-wide integration
- System management mechanisms and policies that provide common solutions for all components for such things as installation, start-up, status monitoring, fault management, performance monitoring, and configuration management

TPS System Characteristics

TPS System Composition

The following four items enable TPS system software to provide a unified system.

- HCI managed components that are named DCOM servers (DCOM refers to Microsoft's object model upon which HCI is based)
 - Make functions and data accessible through industry standards such as OPC and DCOM
- Clients connected (or connectable) to these DCOM servers
 - In some cases, these clients may also be servers as well (i.e., an HCI component)
- Related support software

- All TPS Network systems connected to this Plant Control Network (PCN)

A collection of TPS nodes is typically configured to reside in a TPS domain. Each TPS node has a TPS Administration DCOM object that manages and monitors the TPS domain and controls the HCI managed components configured to run on its node. Each TPS domain includes all instances of the following HCI managed components.

- HCI TPN Server
- CL Server
- HCI PHD Server

TPS System Concepts

The following concepts define the characteristics of a TPS system.

- **TPS Domain** – The namespace (i.e., the set of unique names) of a TPS system is called a TPS domain. It is defined within an NT domain, and uses the NT domain's names for physical nodes, user Ids, and user groups for security checks. The TPS domain consists of all the physical nodes that are defined to be part of the TPS domain and the HCI managed components in them. Each HCI component has a unique name within the TPS domain. The status of the TPS domain is displayed on the TPS System Status Display through these names.
- **Use of NT Domains** – A user may wish to create more than one TPS system (i.e., TPS domain) within an NT domain (in the current implementation they do not know about each other). To manage this NT domain in which the TPS domains have been created, an NT domain server must exist. It may or may not be one of the physical nodes in the TPS domain. In general, display and application program accesses to TPN data and other HCI component data do not require an NT domain server to be running. However, several configuration and housekeeping functions do require this NT domain. These include TPS domain configuration, TPS replication, HCI component configuration, and APP startup. Hence, backup NT domain servers will normally be configured to assure availability of an NT domain server.

Most communications involving TPS system components are within a TPS domain and an NT domain, but there can be some notable exceptions. For example, a client that is not in a TPS domain can connect to an HCI component (such as the HCI TPN Server) that is in a TPS domain. This requires that the client node be configured using the non-TPS domain configuration utility and the NT domain server was configured to support a TPS domain. In addition, a Uniformance Desktop may exist outside of the NT domain containing the TPS domain in which the PHD server it is connected to resides.

- **Data within HCI managed components** – Inside HCI managed components, data and functions are accessible as named TPS objects (an extension of the TPN data point concept). Names of TPS objects within each HCI component are unique within that HCI component. Within each TPN, the namespace is unique, and served by one or more HCI managed components called TPN data servers.
- **Location Transparency** – To access information, a client specifically addresses the HCI component as a logical name, but the physical location of the server is transparent. Names are resolved within the connecting HCI component.
- **Replication of System and User Data** – The configuration of a TPS domain involves defining and sharing system data (e.g., HCI component information) and user data (e.g., graphic files) among the TPS nodes within the TPS domain. This data needs to be kept consistent and up-to-date. TPS system provides replication mechanisms to keep a copy of the relevant system and user data on each node such that a single failure does not affect more than one node.
- **Access Control** – NT security can be set up to allow/restrict accesses appropriately to HCI managed components, including TPN data servers. In addition, for a given TPN, there may be multiple HCI servers, each with its own HCI component name. This allows heavier loads to be served when necessary, and allows routing of different kinds of clients through different servers, to make the system more deterministic.
- **Access to other Systems** – The TPS system uses the concept of a TPS domain to create a unique namespace for a given collection of TPS nodes. Each collection knows of its own TPS domain only. Future releases will provide the functionality of identifying other TPS domains (within the same or different NT domains) and communicating with them. The default TPS domain is the “home” system itself, and generally need not be specified.
- **User Applications executing under NT** – can connect into the system in a number of ways.
 - As client-only applications, connected to the TPS system such as Uniformance Desktop applications, accessing PHD data.
 - As client-only applications, connected to the TPS system through application I/O services or directly through HCI, perhaps using the PHD data or custom data segments in the AM to store state that is visible at the GUS Operations Environment and visible to PHD for historization.

All information (physical nodes, HCI managed components) is maintained at the Plant Control Network (PCN) level and available to all nodes on the PCN.

Note that in a TPS system there may be multiple instances of major components, such as HCI TPN Servers and HCI PHD Servers. This does not imply that these instances inherently know of each other. In fact, the HCI TPN Servers and HCI PHD Servers are not aware of each other. However, applications on each are able to access data from the others because they are connected to the network of named HCI managed components.

TPS System Component Connectivity

Node Roles in TPS System

The following diagram shows the role that a node or workstation in a TPS system can assume. These roles are dependent on their placement within the system network hierarchy and help distinguish between nodes that are strictly part of the TPS system versus ones that may be outside of the TPS system or only loosely coupled to it. Designating the node roles is useful in discussing the various connectivity options.

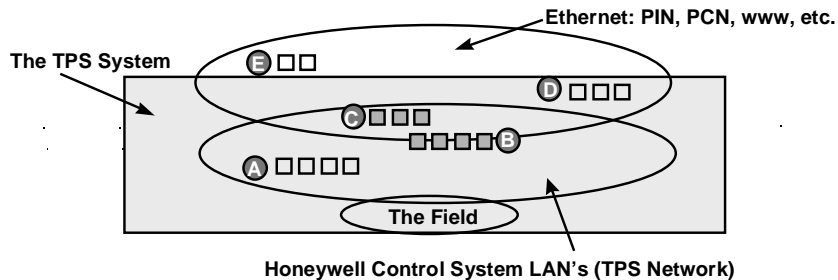

TPS Node Roles:

- Ⓐ Proprietary Control LAN node: No open LAN connection (HM, AM)
- Ⓑ TPS Connected Node: Proprietary control LAN node *with* open LAN connection (GUS, APP)
- Ⓒ TPS Client/Server Node: No proprietary LAN; runs NT and ethernet; HCI present
- Ⓓ TPS Desktop Node: Like #C, except HCI optional; NT Optional
- Ⓔ PCs on ethernet and www: Contains no TPS Software

17395

Figure 4 Node Roles in TPS System

The roles of a node in TPS are defined as follows:

- **A – nodes that are connected to the TPS Network, but not connected to the TPS Plant Control Network (PCN).** This includes all existing TPS Network nodes such as AMs, HMs, etc. Applications at this level do not have explicit knowledge of applications at upper levels.

- **B – the TPS PCN-connected node with direct TPS Network connection.** This includes TPS nodes that are on the PCN and are also connected to a TPS Network through an LCNP board in their physical node (e.g., GUS, APP). Access from these components to the local TPS Network is possible without dependence on the PCN. The components in these nodes also have access to data on the PCN (including other TPNs) by addressing the appropriate PCN component through HCI.
- **C – TPS PCN-connected node without an LCNP board for direct connection to a TPS Network.** Data on the PCN is accessible to these nodes, and data on TPS Networks is accessible by addressing a data server that is connected to the desired TPS Network, i.e., functionality is the same as for Level B, but without a local TPS Network.
- **D – PIN-connected node with TPS Software.** Here there are actually two levels of connection, depending on the specific system configuration.
 - Most of the Level C functions execute where they can be directly connected to the PCN for performance and system control needs. If the physical network layout precludes this, they can be configured to run on nodes that are on the same subnet with other nodes in that TPS system. A client at this level can be part of the TPS domain (though not required) and communicate to HCI managed components.
 - Applications at the Plant Intranet level, such as those running under the Uniformance Desktop (but not limited to these) are set up to connect to a PHD server rather than to connect directly to a TPN data server. This avoids having this load affect TPN performance. There are two methods to make this connection. The first is with a direct connection to PHD (through a network that is separate from the PCN). The second method is a Plant Intranet to PCN connection that allows PIN applications to connect to the HCI PHD Server through the PCN (the same route that is used by User Applications and GUS).
- **E – No TPS System Software.** While not actually a TPS node, this role is included for completeness and describes all nodes on the PIN that do not contain TPS software or communicate to a TPS system.

TPS System Configurations

The flexibility of the TPS system architecture allows for the various hardware and software components to be combined in a wide range of combinations. In its most simple case, a TPS system could be thought of as a TPS Network only. However, to be an open automation system, the minimum TPS system must include at least one Global User Station and most likely includes many open human interface, history, and application nodes. Multiple TPS system components can be put into a single TPS node as long as they can operate within the memory, disk, and computing power of that node.

Defined below are example configurations for a minimum, a typical, and a large system, but by no means do these illustrate all legitimate combinations.

Minimum TPS Configuration

The minimum TPS system must have at least one TPS GUS Operations Environment. The TPS Build Environment is necessary for configuring the system, but it is not a necessary component for normal operation, so it could be removed. User applications, HCI TPN Servers, and PHD functionality can be added separately. Also as a minimum, a TPS node may serve as an AM replacement and have no PCN connection.

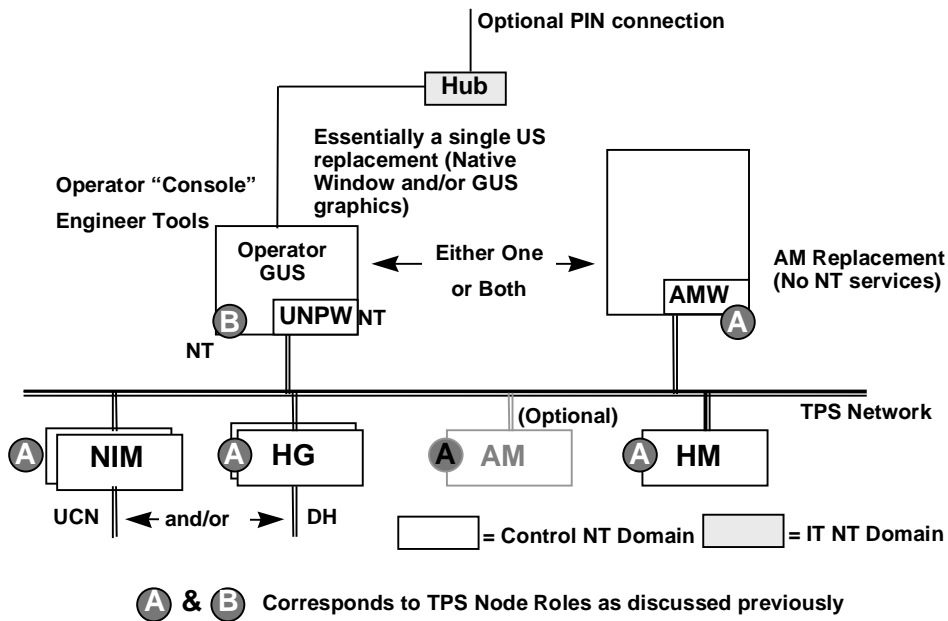

17396

Figure 5 Minimum TPS System Configuration

Typical TPS System Configuration

A typical TPS domain configuration as shown below depicts the user-visible components organized as follows – a three node GUS console, two engineering stations, a TPS client application node, and two server nodes (one for PHD data, the other for TPN data).

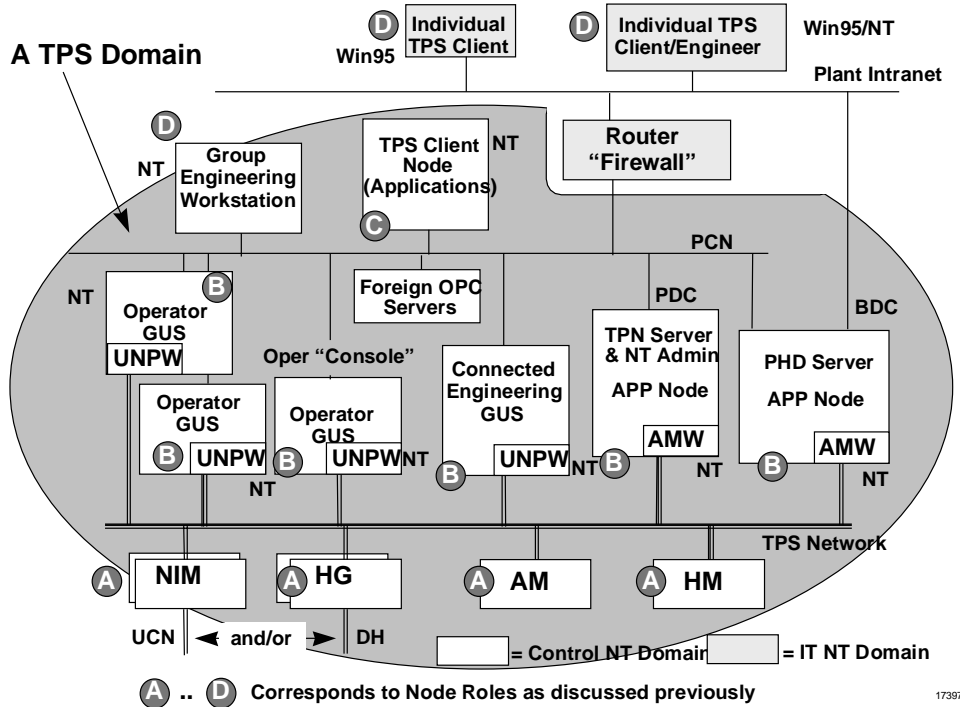
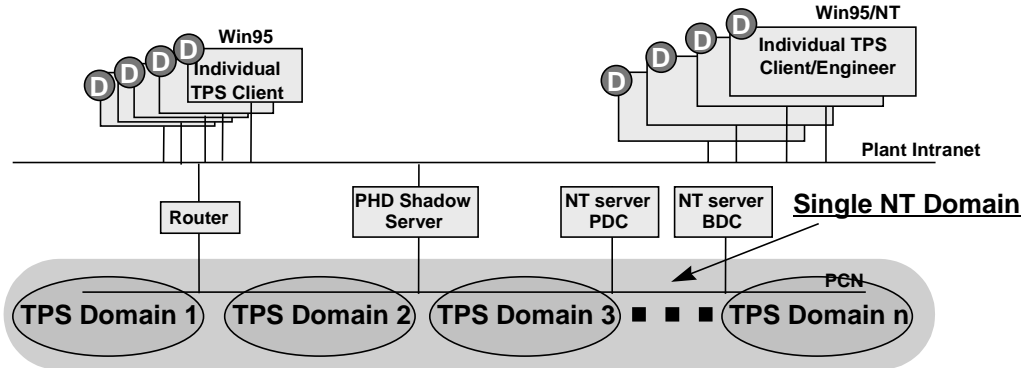

Figure 6 Typical TPS System Configuration

Large Multiple TPS Domain Configuration

In very large sites, a TPS system can be made up of several TPS domains in a single NT domain. TPS nodes can communicate within the domain or between domains as described earlier.



NOTES:

1. The Underlying TPS Networks can either be multiple TPS Networks or a single large one, or multiple TPS Networks joined by NGs.
2. The *entire* TPS system is contained within an NT Domain.
3. The NT Primary Domain Controller (PDC) and Backup Domain Controller (BDC) reside in dedicated PCs on the PCN; they do not need to be high performance PCs and their failure will not result in loss of control.

17398

Figure 7 Large TPS System Configuration

Product Packaging

Packaging of the TPS system allows for hardware/software solutions, as well as software only solutions. In addition, there are many hardware and software components that can optionally be purchased when needed. In the first category, the following hardware/software solutions are offered.

- A GUS node as a Universal Station replacement
- A GUS node as stand-alone GUS (running GUS Graphics)
- A Networked GUS node for administration purposes
- A TPS GUS node that includes HCI/OPC capabilities
- An APP as an AM replacement
- An APP that can run client applications and/or PHD

The second category includes such items as TPS Builder, HCI PHD Server, TPS system electronic documentation, and the HCI client or server toolkit that can be installed on user-supplied hardware. In all cases, the software and electronic documentation is delivered on one or more CD-ROMs and a license key is provided to access the software purchased.

Product Overview

Hardware

The hardware platform for the TPS-connected nodes (TPS node Role - B) is commodity workstation hardware running Windows NT. Open platforms for TPS system are based on the Intel Pentium Pro or Pentium II processors. A range of overall processor speeds, memory sizes, cache sizes, and disk size options for each processor type are supported. The recommended open platform size and performance for a specific TPS system application is determined by that application's needs.

The minimum hardware configuration supported is that released for GUS 100 MR3 and all TPS functions operate with that configuration.

Maximum configurations are set by those reasonably available from the approved platform vendors, which offer platforms of the supported processor types.

Operating Specifications: Environmental specifications (e.g., operating temperature, shock and vibration tolerance, etc.) are those offered commercially by the open platform suppliers. (See "TPS System Ready Consoles" below.)

CE Mark: All open platforms conform to Commercial (Class B) CE Mark specifications. Honeywell-supplied platform packages (EZ-Console, Z-Console, Classic, or Cabinet mount configurations) conform to Industrial (Class A) CE Mark Specifications.

Keyboards: Deskside platforms are available with three keyboard options: Commercial AT101, Industrial CE Mark AT101, and the Desktop Integrated Keyboard which is also industrial CE Mark.

Console mounted platforms are offered with the Console Integrated Keyboard or the Operator Keyboard/Engineering Keyboard (industrial AT101 as above) and Operator Entry Panel (OEP) offerings from previous TPS Network products.

LCNP4

The LCN coprocessor allows the data connection to the TPS Network infrastructure and the operation of TPS Network software personalities. The LCNP4 is a high-performance version of the LCNP offered on previous GUS releases. It is based on the Motorola MC68040 processor and has functionality and performance similar to the K4LCN. The LCNP4 differs in functionality from the LCNP in the following ways.

Product Overview – Global User Station (GUS)

- **Performance:** TPS Network-based performance of the LCNP4 is similar to the K4LCN. The LCNP was similar in performance to the K2LCN.
- **Memory Size:** The LCNP4 has a memory size of 16 megawords (32 megabytes). The LCNP is limited to 8 megawords.
- **Independent Reset:** The LCNP4 allows an independent reset of the NT and RNOS processors. This allows the TPS Network personalities (e.g., the AM) to “ride through” an NT reset.

Both the LCNP4 and older LCNP are available and continue to be valid hosts for GUS. For APP, only LCNP4 is valid.

TPS System Ready Consoles

TPS system platforms are offered in deskside, EZ-Console, Z-Console, and Classic Console mount furniture, or TPS Network Cabinet mount. Deskside and desktop versions are as supplied by the commercial suppliers.

A CRT and keyboard is required for all TPS nodes. These can be the keyboard and CRT built into the consoles (as in GUS), or keyboards and CRTs that rest on work surfaces or adjacent tables for non-GUS TPS nodes mounted in consoles. Systems that require Industrial (Class A) CE-Mark use Industrial CE versions of the keyboard and CRT.

Color monitors from 17-inch to 21-inch diagonal sizes are available for the deskside-packaged units. Deskside touchscreens are offered in 21-inch diagonal size only. Z-Console mounted monitors are 21-inch only with touchscreen. Classic Console versions use a 19-inch multi-synch monitor.

Both industrial (Class A) and commercial (Class B) CE Mark are met in the EZ-Console, Z-Console, Classic Console, and Cabinet packaging options (with appropriate peripherals). Deskside TPS nodes only meet Commercial (Class B) CE Mark requirements.

Intel-Based Platforms

Intel-based platforms are supported and are based on the PentiumPro 200 or the Pentium II as the processor engine with ECC (error correction code) data integrity on both main memory and cache. Platforms can be used in all mounting/furniture options.

Global User Station (GUS)

GUS is available in either a deskside platform or in Classic, Z-Console, and EZ-Console furniture. Each GUS connects to the TPS Network through the LCNP or LCNP4 board. Each GUS also has a built-in Ethernet connection that can be

configured for either 10BaseT or 100BaseT use. This allows a GUS to be connected to an existing network or to be set up with the proper hub, router etc., for a new network. GUS software functions are packaged separately and can be combined to meet function needs on a station-by-station basis.

Base System

The Base System software is the only mandatory software function. It must accompany all TPS Network-connected GUS stations. This software performs the data access between the TPS Network and GUS. Its second main function is to show one Universal Station display through the "Native Window." This Native Window provides the following TPS Network functions.

- Console-Based Alarm Management
- Cross Screen Display Invocation
- Standard Display Access (Group, Detail, Alarm Summary, etc.)
- Access to all Universal Station tools (DEB, NCF, etc.)
- Shared PC Printers and Disks

The Base System is not needed when the Display Builder is used to create new displays, but is needed to test them.

Multiple Displays

The Base System allows viewing of one GUS Display at a time concurrent with the Native Window.

GUS Display Server (local TPN Data)

GUS Display Server contains the components necessary to access TPN data and functions required to operate a process and support on-line display building.

HCI Named Data Access

GUS Displays can access HCI managed components in two ways: through OLE Automation and through named data access (e.g., "SRV1.A100.PV"). Display authors may script GUS displays to invoke any OLE automation interface or named data access to read or write HCI server data.

GUS Utilizing IOMaps

An IOMap is an intermediary HCI/OPC Server that runs "in-process" to the client (see Application I/O below). Therefore, an IOMap may be accessed using OLE Automation

calls in GUS scripts or using named data access in GUS scripts and variable expressions.

IOMaps are the primary method of redirecting data access among HCI servers (not HOPC servers) in a GUS display. As an example, a user may create a GUS display representing a furnace pass and referencing generic data through an IOMap. By changing the data source (i.e., IOMap), the furnace pass display may be reused to represent Furnace Pass 1, Furnace Pass 2, etc.

GUS Standard Displays

Active X controls that emulate the functionality and performance of the standard US displays are available and can be inserted in a GUS graphic. These include

- GUS Alarm Summary Control
- GUS Message Summary Control

In addition, a GUS Group display application is available that emulates the standard US group display. This display conforms to the standard Group Definition as configured in the Area Database.

SafeView

SafeView is a runtime option that lets the operator work in a windowed environment, yet maintain a predictable, repeatable, safe interface to the plant. With SafeView, engineers can divide each screen into regions, and designate what type of display or application goes into each region. They can also decide if displays in each region are movable and sizable. SafeView can also protect the plant window from being overlaid by other applications. Many SafeView configurations can be built, but only one can be active at any given time.

Reusable Components

In addition to the Active X controls listed above, an additional set of reusable components is available with GUS. These include the following.

- The GUS Faceplate which is an Active X control presenting the full functionality of one of the slots in a US group display
- The Honeywell Change Zone which is an embedded picture with the equivalent functionality of the US Change Zone

TPSDDE

TPSDDE lets users access TPN data and send it to applications running on GUS, or up to a plant network for use by other DDE compliant applications.

Uniformance Desktop

The Uniformance Desktop is a set of tools and enablers that provide easy access to history data using PCs. Simple, quick access to high-resolution history data lets the user run analysis and reporting applications that can enhance plant decision making. Desktop components offer easy and flexible access to this data. The Uniformance Desktop includes Process Trend, TDC Viewer, an example Excel spreadsheet with embedded history calls, Visual PHD, and several VB examples.

Process Trend

Process Trend allows a user to trend process history data. A user can easily manipulate the time and value scroll bars to scan through data and zoom in for more detailed analysis. Each trace tag can be independently scrolled, so the user can visually compare tags on a different time basis. The trend picture can be copied to the clipboard for import into a document, or the data behind the trend copied into a file for importing into a tool such as Microsoft Excel for more detailed analysis. A hairline cursor gives the user an exact value for each trace at the point in time where the cursor is placed.

Multiple tags (up to eight) can be plotted in the same window, plus multiple trend windows can be opened. Each trace in each window can be manipulated independently. For example, the time scale can be offset to allow comparison of the current shift's results with a previous shift. The value scale can also be different for each tag.

Conditional Query

Process Trend provides the user with the capability of constructing a conditional query. After submitting the conditional query, the user receives notification of a collection of time intervals where the condition is satisfied. This user is then able to plot data for any of the identified time intervals.

Display Suites

Process Trend users are able to open and save a suite (collection) of up to five Process Trend plots and/or up to 10 analysis windows. The window orientation that appears when the suite is opened is the same as when the suite was previously saved.

TDC Viewer

The TDC Viewer allows the user to look at Universal Station schematics on a PC. The user can view the display at current time or at any time in the past, or replay history data through the display at a controlled rate. Displays are view-only. Many schematics can be viewed at the same time without placing a load on the TPS Network control system, since all data comes from PHD. TDC Viewer uses displays without modification, once uploaded from the History Module to the user's PC.

Note: TDC Viewer is a viewing tool for data contained in the history database. TDC Viewer does not incorporate all of the functions of an active schematic on a Universal Station (US) or a Native Window GUS. The following functions are not available with TDC Viewer.

- Local tags accessible on a US station (i.e., ACKSTAT)
- Trends within schematics
- Tag indirection

Scheduler

This utility is a Microsoft Windows-based application scheduler. A user can schedule any Microsoft Windows program to run periodically or at a specified time. For example, a daily report based on the Microsoft Access report writer using data from PHD can be initiated by the scheduler. A user can view the applications to be scheduled, applications currently running, and the status of applications that were activated by the scheduler. Applications can also be scheduled to run sequentially so that, for example, the daily report does not run until the shift report has completed successfully.

Visual PHD

Visual PHD consists of an OLE Automation Server and Active X Objects for data reporting and application development. The objects consist of a Data control, Text control, Bar control, Graph control, TagText control, and TagPicker control. These objects can be embedded in Visual Basic and Microsoft Office applications to create custom information applications for a particular plant site. For example, a bit map depicting an overhead view of the plant can be imported to Visual Basic, then the OLE objects can be embedded on the picture to create an information schematic. This display can be saved as an executable and e-mailed to anyone in the company.

The Visual PHD Active-X components operate within standard OLE server applications. These include Visual Basic 5.0 and the suite of Microsoft Office 97 applications.

Example Excel Spreadsheet

Visual PHD makes it easy to develop custom Excel applications that require process data. An example spreadsheet is included that can be modified by a user to meet most needs for process data analysis using Excel. It is also easy to create a conditional query of history data using this spreadsheet. The example spreadsheets are compatible with Excel 97 and Excel 95.

Interactive Query

Interactive Query (IQ) provides an easy-to-use mechanism for transferring history data from PHD to Microsoft Excel. One powerful aspect of Interactive Query is the tool's user interface, which allows interactive selection of plant data. Once a request is made, it allows the user to control the flow of data to Excel through its control window interface. The user can request a large amount of history data and then "replay" that information by stepping through samples at the selected rate. Also available is a "refresh" mode, which automatically re-executes a query periodically, to support a live trend, for example.

Dynamic Query (DQ) and Microsoft Query (MQ)

Dynamic Query also history retrieval requests are to be constructed by references to other cells in the Excel spreadsheet. The 128-character limitation on history retrieval requests can be bypassed. A mechanism is provided to place all history retrieval results into an Excel spreadsheet without requiring the user to identify a fixed region before issuing the request.

The user is also provided with the ability to manipulate the result set from a history retrieval request in Microsoft Query.

History Browser

The History Browser provides an easy-to-use mechanism for transferring history data from PHD to Microsoft Access. The result set is placed in a table in a Microsoft Access database, where it can be viewed, exported, reported on, or integrated with data from other sources.

Process History Database (PHD)

Process History Database (PHD) is the process data historian of Honeywell's plant-wide **TotalPlant** Solution system. PHD collects, integrates, and maintains a long-term history of real-time continuous and discrete production, process performance, and process-related data. The PHD Server can collect data from the TPS Network and other data sources. Some key PHD features follow.

Multiple Data Types Supported

PHD supports real, integer, binary, and alphanumeric (text) data types integrated seamlessly in one database. PHD supports a 32-character tag name. The tag name may be the same or different than the tag name used by the source system. For consistency, it is recommended that they be the same.

Tag Configuration

PHD provides the ability to define new or modify existing tags without having to rebuild the database or shut the system down. The number of tags that can be scanned is dependent only on the capability of the processor and the source of the data. PHD also provides a powerful utility to automatically generate the PHD tag parameters and their reference attributes.

Class Tag Configuration

PHD tag definition supports the use of “class tags” that other tags may reference as their parent. Any tag attributes that are not specifically defined for a tag are inherited from its parent class tag. A class tag may in turn inherit values from another class tag. If a class tag attribute is modified, any tags that inherit the attribute dynamically inherit the change. This permits the system to be configured with a set of intelligent default tag attributes. This feature simplifies tag definition and maintenance because the behavior of entire classes of tags can be altered after the tags are defined, simply by modifying the parent class tag.

Data Retrieval Independent of Data Collection

Applications may query data for times that are independent of point scan rates or storage intervals. Accurate measurements for operations transactions can then be determined regardless of the transaction times or duration.

Time Weighted Data Reductions

Reductions, which include min, max, delta, mean, linear regression, running average, and standard deviation are performed on a time-weighted basis vs. sample basis. These reductions return both a reduction value and a composite confidence factor based on the reliability of the source data.

Automatic Engineering Unit Conversions

PHD provides standard engineering unit conversions between absolute values, rates, and accelerations. For example, a flow that is measured in barrels/day can be requested as gallons/hour. Data conversion to and from metric units is also supported. This allows users and applications to request information for a measurement in the units required without having to build conversion functions into the various user tools and applications.

Virtual Calculations

PHD provides the capability to perform a calculation to handle situations such as when lab physical properties are not available for several hours after the sample time. PHD

also provides the ability to evaluate logical time-based inferences of process data or other manual inputs from operator logs. For example, “what was the change in value over the last 5 minutes, hour, etc.?” and “did this change exceed a logic operating threshold?”

PHD returns a calculated result along with the calculated confidence for the result based on the reliability of the tags referenced by the calculation.

Conditional Data Search and Retrieval

PHD provides conditional processing logic for retrieval of data using a conditional statement. PHD provides the ability to review history between a start and end date and examine the values based on conditional expressions.

System Capacity

The resolution of history data and length of history retention is configurable. Typically, a customer keeps high-resolution (scan rate) data online for 2 to 3 years or longer.

Exception Condition Interfaces

The exception condition interface may be linked with any standard RDI polled-type RDI in order to implement scanning controlled by exception conditions. The exception condition interface generates “exception” data for a group of real-time tags by polling them when data for these tags is required, according to the current conditions. The exception condition interface must be linked with an RDI polled interface in order to function. This can be an interface to a real-time system, or a PHD-to-PHD interface running in polled mode.

Automated Backup

PHD provides the ability to perform an on-line backup of the history database with no data loss. PHD also provides the ability to create an archive that may be removed to tape and later restored without having to shut the system down.

Data Compression

PHD provides an innovative data elimination compression technique. Since data is represented as a series of virtual linear segments between points, intermediate values can be eliminated if they can be estimated to within an error tolerance specified for the tag.

HCI PHD Server

The HCI PHD Server provides OPC client access to current values for variables stored in the process history database. It provides both read and write capability for a single variable or a list of variables. Values written to PHD may be forwarded to the data owner.

TPN Event Journal Collection and Storage

PHD collects journals from the event journals on the TPS Network History Module (HM) and inserts the event messages into tables in a relational database to provide relational access to this information. All of the HM journals (sequence of events, operator changes, alarms, etc.) are available from PC applications.

Journals are messages that describe events that occurred on a control system. Typically, these event messages are not available to higher level systems. Many advanced applications need this information.

The TPS Network journals are captured from TPS Networks connected to TPS nodes, or Alpha AXPs (using CM50s). The types of journals that are collected, and the collection (polling) frequency are configurable.

Application Program Execution

While GUS nodes are intended to provide human interface capability; in general, applications, particularly permanently running applications, should execute in separate TPS nodes, independent of the GUS nodes. This allows view and operation from multiple GUSs, and it assures that the CPU and other resource load for application execution and for data accessing do not compete with operator priorities at GUS stations. The APP is designed to provide a good platform for these applications, independent of GUS operation. It has a connection to a TPN (the LCNP/LCNP4 board) using an HCI TPN Server. In addition, it can optionally have a CL Server, PHD with HCI PHD Server, and IOMap Server capability.

NT Client Applications

There are several mechanisms for executing application processes in NT. One is to invoke the client as an "Interactive Process." Another is to setup an automatic login and start the application through the startup group and a third way is invoke the client as a "Service Process" with the User ID set up by the system administrator. In any case, the application ultimately runs under a process that acts as a client to the data server and the TPS system.

CL Server

The CL Server provides a way to launch and schedule NT applications on the APP from CL programs running in the TPN Application Module personality loaded on the LCNP4 board.

Application Scheduling

Scheduling for those applications that require it can be accomplished through the standard AM point-processing mechanism. The CL/AM extensions of the AM personality of the APP provide the ability for a CL/AM program to trigger a new instance of an NT application that starts, executes, and completes. The CL/AM program waits until the execution of the application has completed before continuing. On each activation, the CL program may pass an invocation string to the program being activated. This can be used to communicate the reason for activation.

Only background CL programs may be used to initiate application programs. Multiple applications, activated from a single AM point, are executed serially, the order of execution determined by the CL insertion point order on the AM point.

Application Management

The CL Server provides management capability limited to the installation of single applications within the APP. It assists in the management of executables initiated through the CL/AM extensions defined above. It focuses on the following primary functions.

- Install/deinstall applications which includes registration with CL Server
- View summary and state of installed applications through the CL Server specific portion of the TPS Status Display, but not through HCI named data
- Aborting of selected applications through the CL Server specific portion of the TPS Status Display, but not through HCI named data

Application I/O

Current value I/O interfaces are provided as HCI/OPC interfaces. This includes both the “Custom” C++ interfaces and the OLE Automation interfaces.

HCI TPN Server

The HCI TPN Server provides OPC client access to TPN data and also supports HCI optional interfaces. It provides both read and write capability for a single variable or a list of variables, as well as asynchronous requests.

Application access security is provided through the TPS Security Model that is described later. Applications can specify a TPN key level for their TPN accesses. This key level is checked against **Permissions** on a proxy file previously setup by the administrator. This proxy file mechanism is used to control the ability to change these key levels such that they can be used for setting “program” or “continuous control” access levels.

IOMap Server

In addition to the ability to access an HCI component directly using the HCI/OPC Custom or Automation interfaces, a client application can use an IOMap server. An IOMap server is an intermediary HCI/OPC server that runs “in-process” to the client. It allows IOMaps to be loaded which, when accessed through generic item names, can be redirected through the IOMap configuration to any external HCI/OPC server. This allows the application code to use generic names such that the actual I/O destinations can be determined at build time or at runtime. Some features of IOMaps include the following.

- Ability for IOMaps to be built by the TPS Builder
- Ability for IOMaps be built and modified by executing applications
- Ability to access multiple ultimate HCI/OPC servers (also known as scatter/gather)
- Test value insertion capability
- Ability for IOMaps to be used with GUS Displays as well as for NT application programs.

PHD Use to Reduce TPN Loading

As discussed in the earlier section on PHD, current values of PHD are accessible through an HCI PHD server. As such, PHD, through HCI and IOMaps is an alternative for fetching and storing values. PHD can be and often is used with applications in the following ways.

- Tagnames from the source system are configured in PHD, scanned by PHD independently of applications, and accessed through HCI, perhaps using IOMaps.

If the same value is used by multiple applications or is also historized, this usage could significantly reduce the load on the TPN as compared to direct accesses to the TPN Server.

- PHD Auxiliary Tags are used to store the state of the application, which is useful for communication with other applications or for operator access through GUS. This is an alternative to storing the data on the TPN (for example, in AM custom data segments), which, again, yields significantly reduced TPN loading.

Event Annunciation and Journal Entries

TPS Network Process Alarms and Messages

Process alarms and messages from the TPS Network are presented on the Native Window and the Integrated Keyboard (IKB) exactly as they are on the TPS Network. In addition TPS Network alarms and messages are available within GUS displays as discussed in the previous section on GUS.

TPS Network System Status

TPS Network System status (including LCN, UCN, Data Hiway, module, and box status) is presented on the Native Window and the Integrated Keyboard exactly as they are on the TPN. For system level operations, such as directing node startups, checkpointing, etc., the operator must use the Native Window.

Journals of TPS Network Events

HM Journals are available exactly as they are on the TPN, including data retrieval through the Native Window. In addition, PHD can be configured to collect HM journals and store them into relational tables, where the information is available through various relational query tools.

Application Alarms

NT applications that need to present application conditions such as process alarms to the operator can use AM facilities (e.g., switch data point) to create custom alarms.

NT Event Log

Other events of interest are captured in the NT Event Log, on each TPS node. They are viewed through NT facilities at the node of origination of the event. These events include such things as the following.

- Log-in/log-out

- System configuration changes
- System software errors
- Application errors that are directed to the TPS system event log interface

System Management

Persistent Storage Maintenance (backup and recovery)

Backup Exec for Windows NT from Seagate Software (formerly Arcada) is suggested for use by customers and is provided with the system when a tape drive is purchased.

PHD handles backup and restore independent of other TPS system components. Backup of PHD requires backing up both the reference data and the history data.

The TPS Builder runs on top of MS Access. The user must be able to do database backup and reload, which requires a level of database administration skills.

Journal Display and Maintenance

Journal maintenance is the act of clearing journal entries or saving journal files to a backup media. The NT Event Viewer can be configured for the size of the journal file and for the policy for keeping or discarding events when the log is full. In addition, the log file can be archived and retrieved later for viewing using the Event Viewer. The Administrator is responsible for these maintenance policies.

PHD collects TPN Events and journals them into relational database tables. To view these journals, any tools that can view relational database tables (e.g., MS Access) can be used. Since the event journals are stored in relational tables, queries can be made to search for desired events. The Event Journal tables must be maintained through the relational database maintenance tools.

TPS System Status Display

The TPS System Status Display shows the states of the TPS nodes configured into this TPS domain, and the states of the HCI managed components on them. Node and HCI managed component failures are shown here. Startups and shutdowns can be commanded from this display.

Performance and Network Management

Performance and Network Management provide a means of detecting, correcting, and analyzing processing and communication inefficiencies and faults. The tools provided are a collection of existing NT and TPS Network standard capabilities, as well as optional tools provided by Network Services. These include the following.

- Standard NT Performance Monitor tool
- Standard NT Process View tool
- Standard TPS Network CPU utilization displays

Security Management

A default security policy that predefines NT domain user groups is shipped with each TPS system. The following are the default NT domain user groups.

- Administrators
- TPS Administrators
- Operators
- Supervisors
- Engineers
- Program Users
- Continuous Control Users
- Point Builders
- Intimate Users
- View Only Users
- Backup Operators
- Replicator

Customers can tailor their own specific security policies using the existing NT security administration tools.

System Configuration

System configuration provides the mechanisms for configuring a TPS system and includes the configuration of the following.

- TPS Domain and TPS System Replication attributes
- HCI Managed Components (i.e., HCI TPN Server, HCI PHD Server, etc.)
- Attributes of HCI Managed Components
 - Performance Parameters and Policies (throttling, etc.)
- Time Synchronization

The system administrator uses a stand-alone TPS system configuration tool from which configuration of all HCI managed components can be initiated. This tool is an interactive program that presents the administrator with an interactive tab-dialog style configuration sheets for examining and setting the configuration. From this tool both local and remote TPS nodes and HCI managed components can be configured from a single TPS node. TPS Network node configuration is still done using the Native Window connected to the chosen TPS Network.

Build Environment

The TPS Engineering Environment provides tools for the following activities.

- Control strategy building (ranging from TPN devices to IOMaps)
- PHD configuration
- US Display Translator
- GUS display building
- SafeView workspace building
- HCI Client development
- HCI Server development

TPS Builder

TPS Builder is the foundation for a common build environment and single point configuration for the various aspects of the control solution. The TPS Builder provides the configuration capability for the following TPN nodes: PM, APM, HPM, AM, Hiway Boxes, LM, FSC, Enhanced Program Logic Controller Gateway, and Computer Gateway.

It also supports linking and embedding of any OLE compliant documents into a control drawing and creating GUS Displays from control drawings. TPS Builder templates, libraries, strategies, and projects allow application components to be grouped together in order to construct an entire TPS system application package. Initially, the definition of a common I/O "mapping" mechanism (IOMap) is provided. The IOMap concept supports the development of common TPS system application components that can execute within various TPS system components.

PHD Configuration

The PHD Reference Database defines what PHD collects, how often, and how it is stored. This is also where the definition of the collection groups is stored. Configuring this database is the first step during the implementation of PHD. All points, variables,

and data sources need to be defined. Each variable is assigned to a collection group or groups and the description, engineering units, range, and compression parameters, among others, are defined.

TotalPlant Information is a separate tool and is used by the administrator to set-up the Reference Database, which determines the operation of PHD. To alleviate the task of individually creating each variable to be collected, a Bulk Loader tool is available with PHD. This tool imports the TPN point and parameter information and sets up appropriate tables in the Reference Database. A user can set up defaults and manually tailor the configuration during the bulk load process. Of course, any bulk-loaded variables can be modified later.

Display Translator

Display Translator translates existing US schematics to GUS displays. While the Display Translator does not translate 100% of a display (for example, Overlays and Change Zones are not translated), it does a good job of translating TPS Network subpictures and associated code into GUS Display pictures and script code.

Display Builder

Display Builder is the easy-to-use graphical tool that builds custom GUS operating displays. Through Display Builder, an engineer can create display backgrounds, animation, and other active functions that graphically show plant data or initiate actions. The displays can be linked to points/parameters that represent sensors and controllers in your plant. Display Builder is menu-based and it lets you create displays that have a rainbow of colors, better animation, 3D look, and photographs. It also allows you to embed OLE control objects and applications directly into a display.

This component also includes the following.

- Display Migrator – Providing the ability to migrate GUS picture files to newer revisions
- Display Validator – Providing the ability to perform validation on sets of display files

SafeView Editor

The SafeView Editor provides both a textual and graphical editor for creating SafeView workspaces.

HCI Client Toolkit

The HCI Client Toolkit provides guidelines and interfaces, as well as header files and libraries necessary for compiling and linking clients. This includes both OPC standard

interfaces and value-added enhancements (e.g., asynchronous requests). Additional support is provided for debug-targeted builds of clients, as well as a variety of sample clients.

HCI Server Toolkit

The HCI Server Toolkit provides the necessary “tools” to develop an HCI server. These include implementation guidelines, HCI VC++ wizards, header files, template server code, standard interfaces, utilities class library, and interface definition languages, etc. This toolkit also includes a component configuration library (DLL) and installation scripts.

Distributed Communication (HCI/OPC)

Using Distributed Component Object Model (DCOM) technology, a common Honeywell communication infrastructure is provided that allows Honeywell-supplied TPS system components (e.g., GUS Picture Runtime), as well as third party applications to act as clients to TPS system data sources (e.g., HCI TPN Server, HCI PHD Server). In addition, third party data sources that conform to the OLE for Process Control (OPC) standard can also be data servers to TPS system components. HCI/OPC conceptually has the following three parts.

- The minimum DCOM I/Fs that all servers must implement
- The OLE for Process Control (OPC) standard I/Fs that OPC compliant servers must implement
- Value added I/Fs that Honeywell defines and are implemented in one or more of the HCI/OPC servers, including management interfaces required for HCI managed components

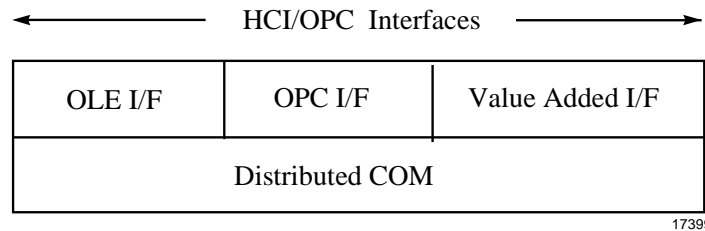

Figure 8 Communication Interface Structure

The following are several points worth noting about the communication infrastructure.

- All interfaces use DCOM as the underlying distribution mechanism and they are not layered on top of each other.
- All HCI managed components have a common set of interfaces in addition to the usual DCOM interfaces. These interfaces include functions such as version identification, status/instrumentation, and other system management-related functions.
- Value-added interfaces are provided as needed to support functionality not defined in OPC, as well as to improve robustness.
- HCI clients and servers are arbitrarily distributable. That is, there is no mechanism that prevents such distribution. As a matter of policy, of course, certain clients and servers may be co-resident.

Value Added Functions and Robustness

Functional and robust enhancements have been added to the standard OPC interfaces. Since DCOM does not directly support timed or prioritized communication requests, the facilities to enable this are provided to HCI/OPC servers (i.e., HCI TPN Server) by the system infrastructure. In addition, convenience functions are provided to unpack data as well as for the handling of asynchronous I/O.

A common set of security, caching, and self-registration mechanisms are provided to the authors of HCI managed components.

HCI/OPC also provides a common mechanism for HCI managed components to perform checkpoints and to support restart from checkpoint. HCI managed components are responsible for performing their own checkpoints and restarts, using this mechanism.

TPS System Naming Structure

Data fetched and stored from HCI managed components (i.e., data sources) through HCI is modeled as a TPS object, which is the TPS extension of the TPN data point. The general form of the name for such an access is

```
//TPSDomainName/HciComponentName/ServerSpecificName
```

where

`TPSDomainName` is the name of the TPS domain – the name space of the set of HCI component names being used. If omitted, the default is the local TPS domain.

`HciComponentName` is the name of the HCI Server containing the object being accessed (for example, an HCI PHD Server).

`ServerSpecificName` is the object name within the HCI server. It may be a multipoint name, indicating structure of the component objects, such as “F100.PV”. TPS Network parameters such as PV, SP, Mode, etc. are modeled as objects within the TPN Server. In general, however, object names are not limited to two parts.

Various levels of name aliasing, indirection, and indexing are also available, as provided by the given HCI server (see the detail specifications).

Currently the following conventions apply to TPS system naming.

- Names are case insensitive and Unicode based
- Access to data in a different TPS Domain is not available; therefore, the `TPSDomainName` need not be used (‘//’ indicates TPS domain name)
- TPS Configuration allows the size of `TPSDomainNames` and `HciComponentNames` to be up to 255 characters
- GUS displays limit the size of the total name form to 80 characters for any HCI data source access and includes a prefix to identify HCI versus HOPC connection
- The HCI PHD Server limits the size of the `ServerSpecificName` portion to 32 characters
- The HCI TPN Server limits the size of the `ServerSpecificName` portion to that of the TPS Networksize which is 31 characters (16 for the tagname, 8 for parameter name, 4 for the index plus 3 for the delimiters)

Security

Security Approach

The following are the key points of the TPS system security.

- Implement security facilities on the NT side of TPS system , with little or no modification of the current TPS Networkside security implementation
- Use the Windows NT security subsystem as the foundation for TPS system security
- Augment NT security only where required to provide TPS system specific security features, and ensure that the augmentations are well integrated with the NT security mechanisms

NT Domain

An NT Domain contains a Primary Domain Controller (PDC) and zero or more Backup Domain Controllers (BDC). The PDC provides for centralized administration of logon accounts, clustering of TPS nodes into a TPS domain, and centralized access to shared resources. In order for the TPS nodes to provide security when connected to a network, the PDC also provides the security control for access to shared resources in the NT domain. An NT domain may also be physically separated into an NT resource domain and an NT account domain. Security within a TPS system accommodates this approach.

TPS Domain

A TPS Domain consists of all physical TPS nodes defined to be a part of the same namespace. Security on HCI managed components within that namespace is based on NT's security mechanisms.

User ID Verification

In TPS system, a user's identification must be verified to ensure that the user is really who he/she claims to be. In most cases, this is accomplished through the standard NT log-on mechanism by entering a user identifier and verifying it by supplying a password. Although not required, it is recommended that every user have a unique user ID. This enables every action on the system to be associated with an individual, i.e., it provides individual accountability. Also, there is less chance of compromise with individual user ID/password combinations than with group user IDs and passwords. Group user IDs and passwords tend to be more readily passed around by word of mouth or by labeling the console, resulting in no security.

Access Rights

Access rights are the capabilities that can be assigned to a user or group such as the ability to create accounts.

Security Objects

An entity to which access is controlled by Permissions. Examples in TPS of access writes granted through **Permissions** are: Files (Read/Write/Execute) and HCI TPN Server (launch, connect).

Permissions

Permissions are associated with exactly one security object and control access to this object. In TPS system, these are standard NT Permissions.

Proxy Files

Proxy files are empty NT files upon which NT permissions are set to control the HCI client access to and HCI server.

User Groups

For TPS system, it is recommended that all access rights be assigned to groups, and that individuals obtain these access rights indirectly by assignment to groups. NT supports the capability of defining groups of users, and assigning access rights to these groups. A single individual can belong to multiple groups. Groups can be assigned meaningful names, such as Operator, Engineer, etc. Assigning access rights to groups can greatly simplify the security administration task, in that group names tend to be more stable than individual assignments. Thus, if a person's duties change, she/he can be reassigned to different groups without the need to change the PERMISSIONS of every object in the system to which the person had access.

The following groups are predefined and shipped with the TPS systems.

- Administrators
- TPS Administrators
- Operators
- Supervisors
- Engineers
- Program Users
- Continuous Control Users

- Backup Operators
- Replicators
- View Only Users

Permissions on TPS system security objects default to appropriate combinations of these groups. Security administration tools is provided to allow the user to configure site-specific security policies as required.

Groups can also be used to control access from sets of applications. For example, a “PCN_Applications” group could be defined and connect rights to various data servers (representing TPS Networks or user databases, etc.) could be assigned to that group. If there are multiple servers to a given TPS Network, accesses from human interface and from applications could be directed to separate servers, for increased determinism.

Operators

Operators log on to GUS by a normal NT log-on, at which time NT log-on mechanisms find the associated groups, and manufacture the security ID for the interactive process that GUS accesses use.

Interactive User Interface

The interactive user TPN keylock function is implemented as a logical function, with log-on and password mechanisms, and the physical key is no longer necessary. (Optionally, the physical key can be used in place of this functionality.) GUS applications that are invoked from displays and operator actions execute with the operator’s authority, and TPN accesses use the keylock level set by this procedure.

TPSDDE and File Transfer

The TPSDDE server is secured by NT activate and connect permissions that select what groups/users are permitted to activate or connect to it. The File Transfer capability is secured by a separate log-on to the File Transfer server, with levels of access capabilities and a password for each level.

PHD

PHD security is maintained separately from TPS system security, since the PHD product is independently available on platforms other than NT. However, the underlying concepts are quite similar to the NT-based concepts described in this section. In the Windows NT environment, PHD users can take advantage of NT security definition in configuring the PHD security mechanisms.

There is a direct correspondence between TPS system “user groups” and PHD “roles.” “Role” definitions are maintained by PHD in its Reference Database. Security for ability to perform configuration must be defined to allow a Role the authority to configure tags and/or functions. Special security rules apply to the configuration of RDIs.

Configuration of Read/Write security on a PHD tag is exception based. The default security for a tag is read and write. Once a security entry has been made for a tag, each Role that is permitted data access to the tag must be identified in the tag configuration.

Security Objects and Access Control Mechanisms

The following table lists TPS system security objects, where they are configured, and access control mechanisms.

Table 1 TPS System Security Objects and Access Control Mechanisms

Security Object	Where Configured	Access Control Mechanism
TPN Functions & Data	TPN (NCF, etc.)	TPN Access Level Setting
TPN Access Levels	HCI TPN Server in TPS Configurator	NT Permissions on proxy files
GUS Key Levels	Software Keylock in Native Window	Physical key settings or passwords, managed by LCNP resident functions
TPN Function Levels	HCI TPN Server in TPS Configurator	NT Permissions on proxy files
HCI TPN Server	NT Explorer	Permissions on HCI TPN Server (launch, connect)
Engineering Repository (Files and databases)	NT Explorer	Permissions on database files and directories
System Repository (NT Registry)	NT Explorer	Permissions on database files and directories
HCI PHD Server	NT Explorer	Permissions on HCI PHD Server (launch, connect)
PHD through Visual PHD I/F and PHD API	TPI (configurator)	PHD Reference Database Configuration
User Data Files	NT Explorer	Permissions (R/W/E)
Selected HCI methods	HCI Server in TPS Configurator	NT Permissions on proxy files
Other DCOM Servers	NT Explorer	Permissions

TPS Builder

The TPS Builder uses the NT user Log-in and built in security at the file level to provide access to logging into NT, running the application itself, and accessing the configuration data in the database files.

Related Products and Applications

Network and Integration Services

Network and Integration Services offer design, implementation, maintenance, and optimization of networks to support the mission-critical applications within the plant. This includes "industrial-strength networks," which possess the reliability, robustness, performance, and security traditionally associated with the process control network. The following services are available.

- Consulting and Design Services
- Baseline and Assessment Services
- Integration Engineering Services
- Network Administration and Support
- Performance Management Services
- Network Monitoring Services

User Alert

User Alert is an Abnormal Situation Management (ASM) application designed to enable the operator to proactively define automated alerts that assist with the overall monitoring and control of the process unit and its associated on-going tasks. The User Alert concept has been validated through involvement and feedback from the Abnormal Situation Management Industry consortium.

The User Alert application provides the mechanism for industrial board operators to be alerted when user-defined conditions have occurred, thereby improving effectiveness by minimizing the constant recall requirements of the operator and by reducing the loading of the alarm system. By leveraging the TPS system functionality, the User Alert application automatically monitors plant conditions which, if not attended, could result in reduced operating performance, abnormal incidents, or plant losses. This technology breakthrough offers more unit integrity and confidence to operators and plant management than ever before and is unmatched in the operating environment.

Equipment Health Management (EHM)

Equipment Health Management (EHM) solutions focus on plant maintenance and reliability. These solutions balance reliability, predictive, and preventive maintenance strategies to deliver optimum plant availability.

EHM gathers data from specific plant assets for analysis and action. As an open solution, it can be applied to any asset. Typical plant assets include pumps, motors, heat exchangers, analyzers, instrumentation, compressors, control valves, pressure relief valves, and more. Reliability and maintenance engineers are provided with a consistent desktop environment that gathers data from a variety of sources, such as engineering documents, plant history, maintenance records, field sensors, and control systems. Through the EHM Alert Manager, data is analyzed and organized into symptoms and faults. This is accomplished by incorporating new Honeywell solutions, such as heat exchanger and control valve analysis, along side with third party providers for vibration monitoring, motor analysis, and other niche solutions. The Reliability Engineer can then automate follow-up through the direct integration with computer-based maintenance management and documentation systems.

Advanced Control Applications

Advanced control applications are hosted on Windows NT-based TPS nodes (such as the APP or TPS Client node) and are an integral part of the TPS system architecture. These applications provide the essential technologies for enabling companies in the process industries to compete effectively and attain profitability goals. These applications include

- Profit Suite
- Oil Movement and Storage
- **TotalPlant** Batch

Profit Suite

Profit Suite provides a layered approach to advanced control and optimization. Following a bottoms-up methodology, each application layer adds an increased level of optimization capability. Because applications are complementary and designed to work together effectively, they represent an easily expandable optimization system.

Profit Suite applications provide the following increasing levels of capability.

- Profit Controller, employing Honeywell's Robust Multivariable Control Technology (RMPCT), the industry's leading algorithm for advanced control and local optimization
- Profit Optimizer, incorporating breakthrough cooperative optimization technology for steady-state and dynamic optimization across multiple units of a plant
- ProfitMax, a first-principles process modeling and non-linear optimization system for highly non-linear processes or those demanding extensive modeling efforts. ProfitMax incorporates Dot Products' world-leading NOVA™ open-equation optimization and modeling system

Oil Movements and Storage

Oil Movements and Storage (OM&S) application software package provides refinery off-sites tools for carrying out oil movement operations more effectively. These include the following.

- The OM&S Storage Data Management (SDM) that collects and maintains information pertaining to the status and contents of each tank at a refinery
- The OM&S Blend Ratio Control (BRC) that controls the in-line blending process to ensure that blended products meet blend recipe specifications
- The OM&S Blend Property Control (BPC) that allows operations to efficiently blend fuels to the required specifications, while optimizing the blend
- The OM&S Task Monitor Module (TMM) that helps operators manage and prioritize the many simultaneous activities involved in material movement
- The OM&S Task Control Module (TCM) provides facilities for automating and controlling movement operations
- The Path Finder Module (PFM) is an optional enhancement to TMM and TCM, which improves on the oil movement facilities provided by these modules
- The OM&S Off-Sites Database Module (ODM) provides facilities for the collection, archiving, and reporting of inventory, blend, task and laboratory data in a relational database environment

TotalPlant Batch

TotalPlant Batch is Honeywell's batch automation solution. It provides the functionality to manage and coordinate operations in batch processes. **TotalPlant** Batch is scalable and integrated with TPS system. It provides standard displays for monitoring and controlling of batch operations. The Archiver option permits the exporting of batch journals to ODBC compliant relational databases and other applications for batch reporting and analysis.

Related Products and Applications – Advanced Control Applications

TotalPlant Batch is provided with a set of graphical configuration tools to simplify project implementation. Equipment Editor is used to define the batch process equipment and Recipe Editor is used to create and manage the library of master recipes.

Glossary

Acronyms and Abbreviations

Acronyms and abbreviations used in this document include the following.

AM — Application Module; A proprietary node on the TPS Network that provides a platform for advanced control applications

AMW — AM Personality Image loaded into the LCNP portion of an APP

APM —Advanced Process Manager

APP — Application Processing Platform

ASM — Abnormal Situation Management

BDC — Backup Domain Controller

CL — Control Language

CM50 — Computer Module 50

DEB — Data Entity Builder

DCOM— Distributed Component Object Model

DQ — Dynamic Query

EHM—Equipment Health Management

FSC — Fail Safe Controller

GUS — Global User Station

HCI — Honeywell Communications Interface

HCI/OPC — The complete set of interfaces and functions available to client applications used to access HCI named data.

HM — History Module; a proprietary node on the TPS Network that serves as the historian and file server.

HOPC —This term refers to Honeywell's proprietary interface to the TPS Network data and alarms.

HPM — High Performance Process Manager

IQ — Interactive Query

Glossary

K4LCN— An LCN Card that runs a TPN personality (such as AM, HM)

LCN— Local Control Network (now referred to as the TPN)

LCNP or LCNP4—Local Control Network Processor boards

LM—Logic Manager

MQ— Microsoft Query

NCF— Network Configuration File

OPC— OLE (Object Linking and Embedding) for Process Control

PCN—Plant Control Network

PDC—Primary Domain Controller

PHD— Process History Database

PM— Process Manager

PV— Process Variable

RDI— Realtime Data Interface

SP— Set Point

TDC 3000— The primary control system offered by Honeywell prior to release 410. This includes the TPN, UCN, and connected field devices.

TPI— **TotalPlant** Information

TPN— TPS Network

TPS— **TotalPlant** Solution

TPSDDE— **TotalPlant** Solution Dynamic Data Exchange – a server of TPN data used for DDE aware applications (e.g., Excel)

UCN— Universal Control Network

UNPW—Universal Personality for Workstation

US—Universal Station

Terminology

Specialized terminology used in this document includes:

Application Processing Platform — The Application Processing Platform (APP) is the open application host for the Honeywell TPS system. It is a secure application host that makes it possible to integrate advanced control or information management applications.

NT Domain — A group of computers and devices on a network that are administered as a unit with common rules and procedures. The NT domain provides an administrator a single point from which to administer user accounts, hard drives (shares), and network printers.

Global User Station — Global User Station is an intuitive and productive human interface to the Honeywell TPS system. This station makes plant-wide information easily accessible for needed business and control information.

HCI Managed Components — named DCOM servers that support the value added HCI/OPC interfaces and can be managed through the TPS Status Display. Each HCI Managed Component has a unique name within a TPS Domain.

HCI Named Data — Data that is within or owned by an HCI Managed Component and is accessible as a named TPS object. The object name is an extension of the TPN data point concept and must be unique within that HCI Managed Component.

Plant Control Network — The portion of the Plant Intranet, which connects control critical TPS nodes. It is isolated from the Plant Intranet through router/bridges for security and robustness purposes. This network is also known as the “industrial-strength” network.

Plant Intranet — The Plant Intranet is the open network that exists throughout the plant; is used by plant personnel for viewing process data, but is not guaranteed to have near 100% availability.

TPS Domain — The namespace of a TPS system and all physical TPS nodes defined within that namespace. It is defined within an NT domain and uses the NT’s domain’s names for physical nodes, user Ids, and user groups for security checking.

TPS Network — Refers to the control platform underlying the TPS system (TPN and UCN).

TPS Node — This is a general generic term that collectively refers to a node on which TPS runs and is part of a TPS domain. It can refer to a GUS node, APP, and/or other types of TPS nodes.

TotalPlant Solution System (TPS system) — Beginning with R510 and with the introduction of GUS, TDC 3000^x evolved to become the **TotalPlant** Solution system (TPS system for short). This name applies to any system running R510 or later software, regardless of the presence of a TPS component.

Uniformance — TPS Uniformance (from Unified for Performance) is a unified information and applications software system residing within Honeywell's **TotalPlant** Solution (TPS) system to enable improved plant management and performance. The system provides a comprehensive solution to meet complex and demanding plant management needs in the process industries.

FAX Transmittal**FAX No.: (602) 313-4842**

To: Bill Cline**Total FAX pages:** _____
(including this page)

Reader Comments

Title of Document: TPS System OverviewDocument Number: TP01100Issue Date: 11/98**Comments:** _____

Recommendations: _____

FROM:**Name:** _____ **Date:** _____**Title:** _____**Company:** _____**Address:** _____**City:** _____ **State:** _____ **ZIP:** _____**Telephone:** _____ **FAX:** _____**FOR ADDITIONAL ASSISTANCE**

Write	Call
Honeywell Inc. Industrial Automation and Control Automation College 2820 West Kelton Lane Phoenix, AZ 85053-3028	Technical Assistance Center (TAC) 1-800-822-7673 (48 contiguous states except Arizona) 602-313-5558 (Arizona)

Honeywell

Industrial Automation and Control

Automation College

2820 W. Kelton Lane

Phoenix, AZ 85053-3028