

# SIEMENS

## Microcomputer Components

8-Bit CMOS Single-Chip Microcontroller

### SAB 80C515 / SAB 80C535

# SIEMENS

## High-Performance 8-Bit CMOS Single-Chip Microcontroller

**SAB 80C515/80C535**

### Preliminary

**SAB 80C515/80C515-16** CMOS microcontroller with factory mask-programmable ROM  
**SAB 80C535/80C535-16** CMOS microcontroller for external ROM

- 8 K × 8 ROM (SAB 80C515 only)
- 256 × 8 RAM
- Six 8-bit I/O ports, one input port for digital or analog input
- Three 16-bit timer/counters
- Highly flexible reload, capture, compare capabilities
- Full-duplex serial channel
- Twelve interrupt vectors, four priority levels
- 8-bit A/D converter with 8 multiplexed inputs and programmable internal reference voltages
- 16-bit watchdog timer
- Boolean processor
- Most instructions execute in 1 μs (750 ns)
- 4 μs (3 μs) multiply and divide
- External memory expandable up to 128 Kbytes
- Backwardly compatible with SAB 8051
- Functionally compatible with SAB 80515
- Idle and power-down mode
- Plastic leaded chip carrier package: P-LCC-68
- Plastic Metric Quad Flat Package P-MQFP-80
- Two temperature ranges available:
  - 0 to 70 °C (for 12, 16, 20 MHz)
  - 40 to 85 °C (for 12, 16 MHz)

The SAB 80C515/80C535 is a powerful member of the Siemens SAB 8051 family of 8-bit microcontrollers. It is designed in Siemens ACMOS technology and is functionally compatible with the SAB 80515/80535 devices designed in MYMOS technology.

The SAB 80C515/80C535 is a stand-alone, high-performance single-chip microcontroller based on the SAB 8051/80C51 architecture. While maintaining all the SAB 80C51 operating characteristics, the SAB 80C515/80C535 incorporates several enhancements which significantly increase design flexibility and overall system performance.

In addition, the low-power properties of Siemens ACMOS technology allow applications where power consumption and dissipation are critical. Furthermore, the SAB 80C515/80C535 has two software-selectable modes of reduced activity for further power reduction: idle and power-down mode.

The SAB 80C535 is identical with the SAB 80C515 except that it lacks the on-chip program memory. The SAB 80C515/80C535 is supplied in a 68-pin plastic leaded chip carrier package (P-LCC-68) or in a plastic metric quad flat package (P-MQFP-80).

There are versions for 12, 16 and 20 MHz operation and for 16 MHz operation and for extended temperature ranges – 40 to 85 °C. Versions for extended temperature range – 40 to + 110 °C are available on request.

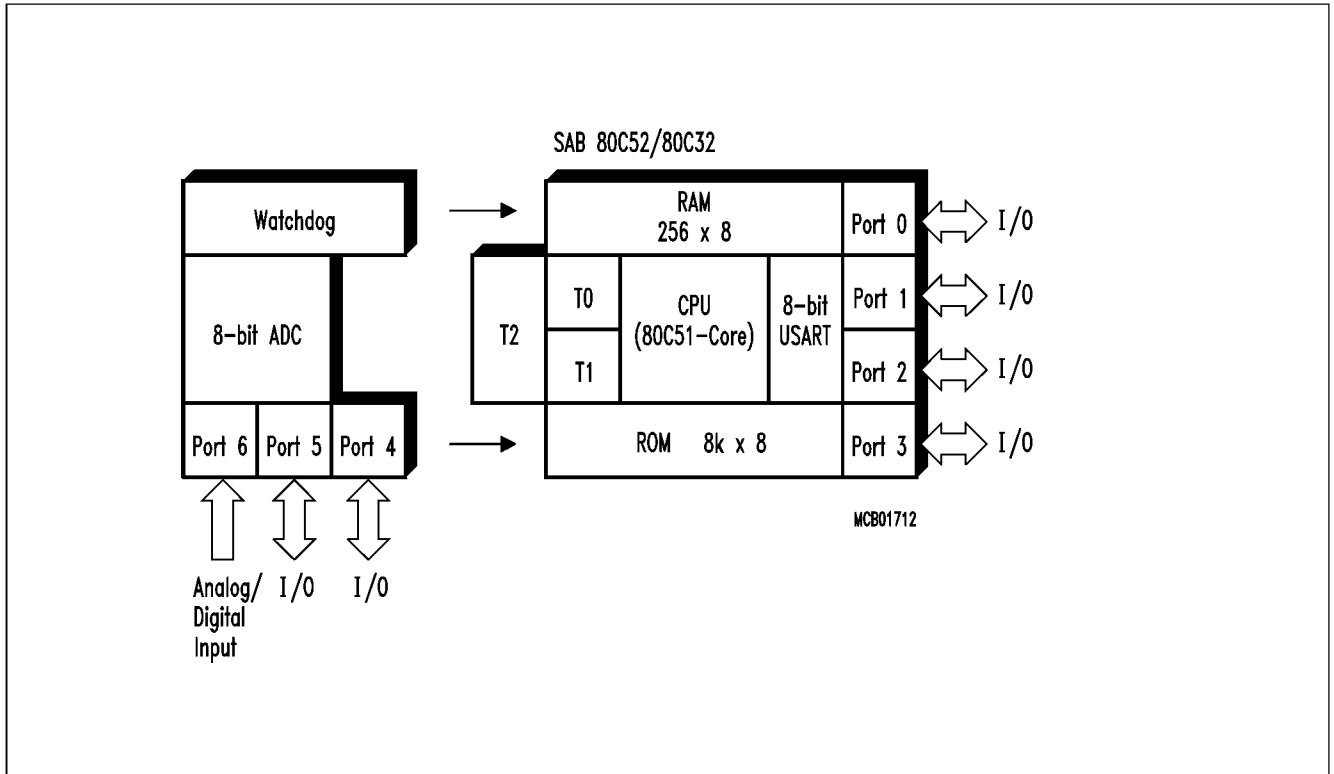

### Ordering Information

Type	Ordering Code	Package	Description 8-Bit CMOS Microcontroller
SAB 80C515-N	Q67120-DXXXX	P-LCC-68	with mask-programmable ROM, 12 MHz
SAB 80C535-N	Q67120-C0508	P-LCC-68	for external memory, 12 MHz
SAB 80C515-N-T40/85	Q67120-DXXXX	P-LCC-68	with mask-programmable ROM, 12 MHz ext. temperature – 40 to + 85 °C
SAB 80C535-N-T40/85	Q67120-C0510	P-LCC-68	for external memory, 12 MHz ext. temperature – 40 to + 85 °C
SAB 80C515-16-N	Q67120-DXXXX	P-LCC-68	with mask-programmable ROM, 16 MHz
SAB 80C535-16-N	Q67120-C0509	P-LCC-68	for external memory, 16 MHz
SAB 80C535-16-N-T40/85	Q67120-C0562	P-LCC-68	for external memory, 16 MHz ext. temperature – 40 to + 85 °C
SAB 80C535-20-N	Q67120-C0778	P-LCC-68	for external memory, 20 MHz
SAB 80C535-M	Q67120-C0857	P-MQFP-80	for external memory, 12 MHz
SAB 80C515-M	Q67120-DXXXX	P-MQFP-80	with mask-programmable ROM, 12 MHz
SAB 80C535-M-T40/85	Q67120-C0937	P-MQFP-80	for external memory, 12 MHz ext. temperature – 40 to + 85 °C
SAB 80C515-M-T40/85	Q67120-DXXXX	P-MQFP-80	with mask-programmable ROM, 12 MHz ext. temperature – 40 to + 85 °C

Notes: Versions for extended temperature range – 40 to + 110 °C on request.  
The ordering number of ROM types (DXXXX extension) is defined after program release (verification) of the customer.

**Pin Configuration**  
(top view)

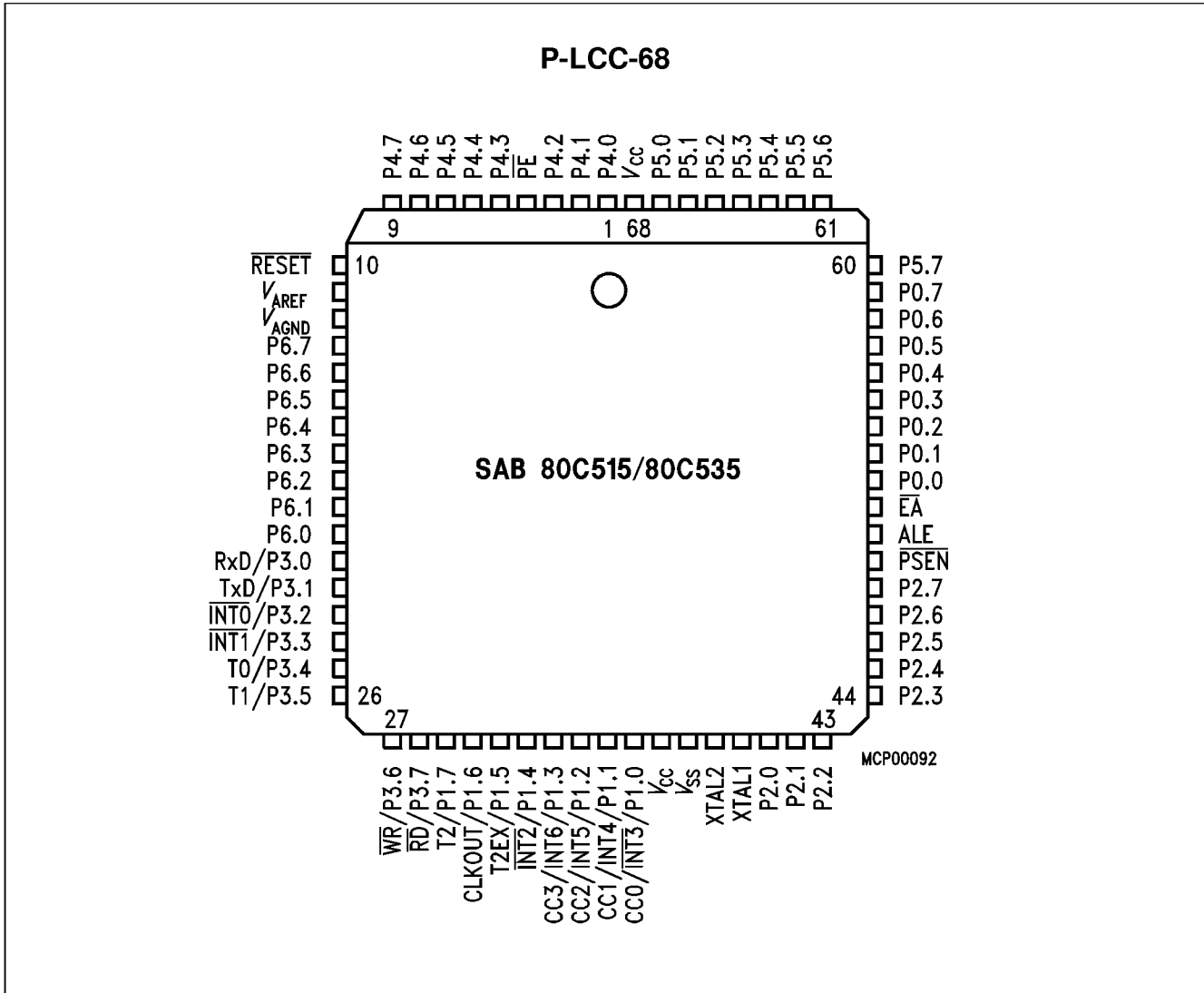

**Pin Configuration**  
(top view)

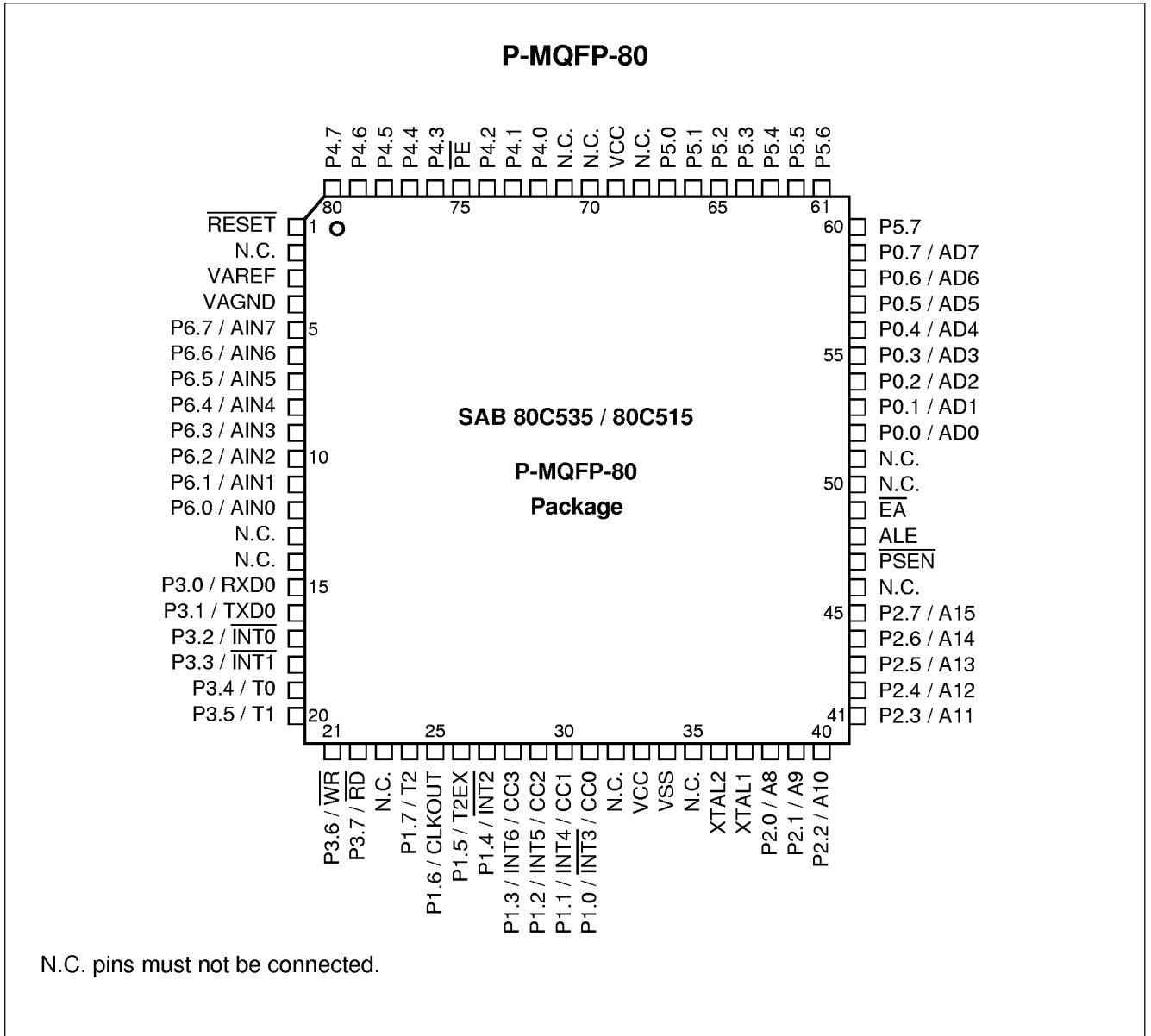

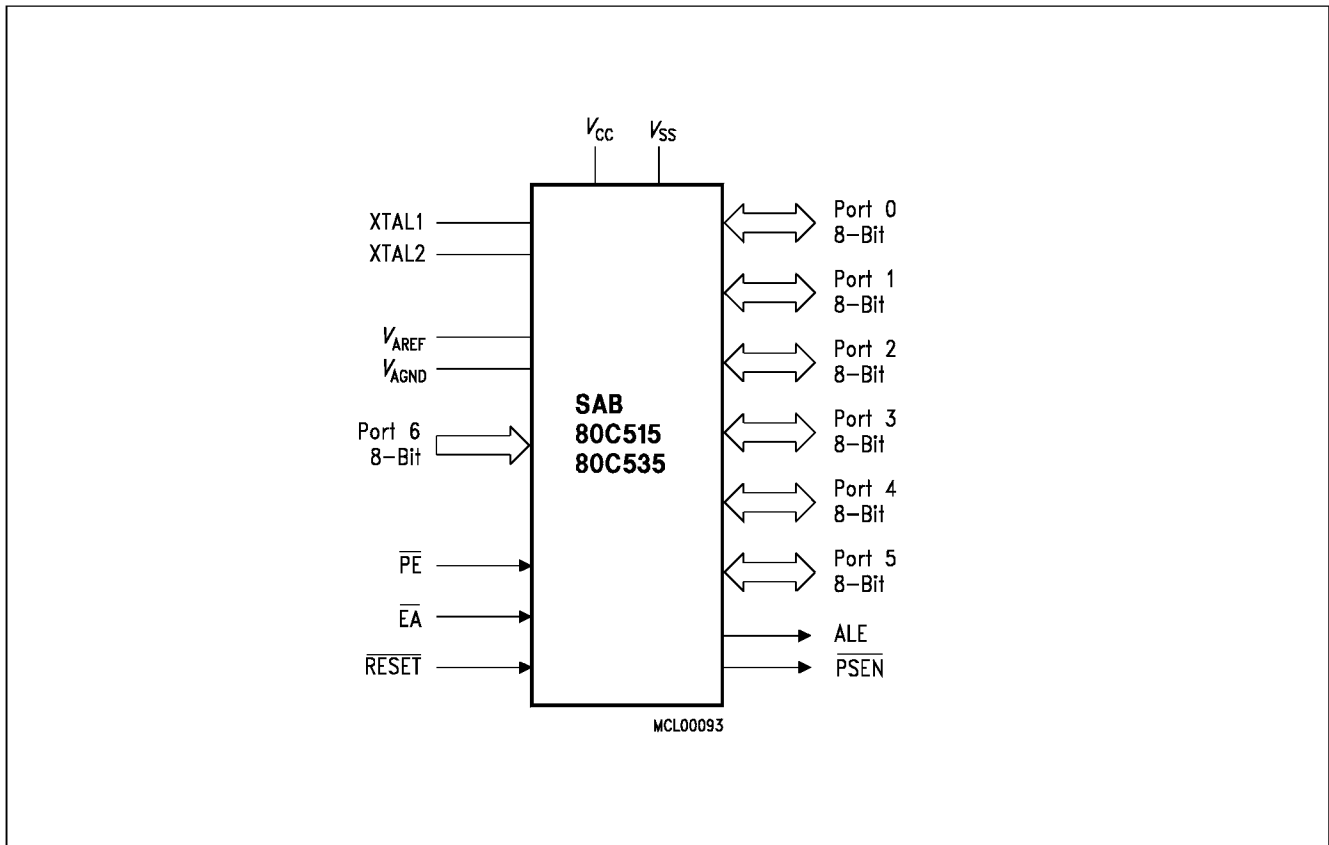

Logic Symbol

## Pin Definitions and Functions

Symbol	Pin P-LCC-68	Pin P-MQFP-80	Input (I) Output (O)	Function
P4.0-P4.7	1-3, 5-9	72-74, 76-80	I/O	<b>Port 4</b> is an 8-bit bidirectional I/O port with internal pullup resistors. Port 4 pins that have 1's written to them are pulled high by the internal pullup resistors, and in that state can be used as inputs. As inputs, port 4 pins being externally pulled low will source current ( $I_{IL}$ in the DC characteristics) because of the internal pullup resistors.
$\overline{PE}$	4	75	I	<b>Power saving mode enable</b> A low level on this pin enables the use of the power saving modes (idle mode and power-down mode). When $\overline{PE}$ is held on high level it is impossible to enter the power saving modes.
$\overline{RESET}$	10	1	I	<b>Reset pin</b> A low level on this pin for the duration of two machine cycles while the oscillator is running resets the SAB 80C515. A small internal pullup resistor permits power-on reset using only a capacitor connected to $V_{SS}$ .
$V_{AREF}$	11	3		<b>Reference voltage</b> for the A/D converter
$V_{AGND}$	12	4		<b>Reference ground</b> for the A/D converter
P6.7-P6.0	13-20	5-12		<b>Port 6</b> is an 8-bit unidirectional input port. Port pins can be used for digital input if voltage levels simultaneously meet the specifications for high/low input voltages and for the eight multiplexed analog inputs of the A/D converter.



## Pin Definitions and Functions (cont'd)

Symbol	Pin P-LCC-68	Pin P-MQFP-80	Input (I) Output (O)	Function
P3.0-P3.7	21-28	15-22	I/O	<p><b>Port 3</b> is an 8-bit bidirectional I/O port with internal pullup resistors. Port 3 pins that have 1's written to them are pulled high by the internal pullup resistors, and in that state can be used as inputs. As inputs, port 3 pins being externally pulled low will source current (<math>I_{IL}</math>, in the DC characteristics) because of the internal pullup resistors. Port 3 also contains the interrupt, timer, serial port and external memory strobe pins that are used by various options. The output latch corresponding to a secondary function must be programmed to a one (1) for that function to operate. The secondary functions are assigned to the pins of port 3, as follows:</p> <ul style="list-style-type: none"> <li>– RxD (P3.0): serial port's receiver data input (asynchronous) or data input/output (synchronous)</li> <li>– TxD (P3.1): serial port's transmitter data output (asynchronous) or clock output (synchronous)</li> <li>– <math>\overline{\text{INT0}}</math> (P3.2): interrupt 0 input/timer 0 gate control input</li> <li>– <math>\overline{\text{INT1}}</math> (P3.3): interrupt 1 input/timer 1 gate control input</li> <li>– T0 (P3.4): counter 0 input</li> <li>– T1 (P3.5): counter 1 input</li> <li>– <math>\overline{\text{WR}}</math> (P3.6): the write control signal latches the data byte from port 0 into the external data memory</li> <li>– <math>\overline{\text{RD}}</math> (P3.7): the read control signal enables the external data memory to port 0</li> </ul>

## Pin Definitions and Functions (cont'd)

Symbol	Pin P-LCC-68	Pin P-MQFP-80	Input (I) Output (O)	Function
P1.7-P1.0	29-36	24-31	I/O	<p><b>Port 1</b> is an 8-bit bidirectional I/O port with internal pullup resistors. Port 1 pins that have 1's written to them are pulled high by the internal pullup resistors, and in that state can be used as inputs. As inputs, port 1 pins being externally pulled low will source current (<math>I_{1L}</math> in the DC characteristics) because of the internal pullup resistors. The port is used for the low-order address byte during program verification. Port 1 also contains the interrupt, timer, clock, capture and compare pins that are used by various options. The output latch corresponding to a secondary function must be programmed to a one (1) for that function to operate (except when used for the compare functions). The secondary functions are assigned to the port 1 pins as follows:</p> <ul style="list-style-type: none"> <li>– <math>\overline{\text{INT3/CC0}}</math> (P1.0): interrupt 3 input/compare 0 output/capture 0 input</li> <li>– INT4/CC1 (P1.1): interrupt 4 input/compare 1 output/capture 1 input</li> <li>– INT5/CC2 (P1.2): interrupt 5 input/compare 2 output/capture 2 input</li> <li>– INT6/CC3 (P1.3): interrupt 6 input/compare 3 output/capture 3 input</li> <li>– <math>\overline{\text{INT2}}</math> (P1.4): interrupt 2 input</li> <li>– T2EX (P1.5): timer 2 external reload trigger input</li> <li>– CLKOUT (P1.6): system clock output</li> <li>– T2 (P1.7): counter 2 input</li> </ul>

**Pin Definitions and Functions** (cont'd)

Symbol	Pin P-LCC-68	Pin P-MQFP-80	Input (I) Output (O)	Function
XTAL2 XTAL1	39 40	36 37		<p><b>XTAL2</b> Input to the inverting oscillator amplifier and input to the internal clock generator circuits.</p> <p><b>XTAL1</b> Output of the inverting oscillator amplifier. To drive the device from an external clock source, XTAL2 should be driven, while XTAL1 is left unconnected. There are no requirements on the duty cycle of the external clock signal, since the input to the internal clocking circuitry is divided down by a divide-by-two flip-flop. Minimum and maximum high and low times and rise/fall times specified in the AC characteristics must be observed.</p>
P2.0-P2.7	41-48	38-45	I/O	<p><b>Port 2</b> is an 8-bit bidirectional I/O port with internal pullup resistors. Port 2 pins that have 1's written to them are pulled high by the internal pullup resistors, and in that state can be used as inputs. As inputs, port 2 pins being externally pulled low will source current (<math>I_{IL}</math> in the DC characteristics) because of the internal pullup resistors.</p> <p>Port 2 emits the high-order address byte during fetches from external program memory and during accesses to external data memory that use 16-bit addresses (MOVX@DPTR). In this application it uses strong internal pullup resistors when issuing 1's. During accesses to external data memory that use 8-bit addresses (MOVX@Ri), port 2 issues the contents of the P2 special function register.</p>

## Pin Definitions and Functions (cont'd)

Symbol	Pin P-LCC-68	Pin P-MQFP-80	Input (I) Output (O)	Function
$\overline{\text{PSEN}}$	49	47	O	The <b>Program store enable</b> output is a control signal that enables the external program memory to the bus during external fetch operations. It is activated every six oscillator periods, except during external data memory accesses. The signal remains high during internal program execution.
ALE	50	48	O	The <b>Address latch enable</b> output is used for latching the address into external memory during normal operation. It is activated every six oscillator periods, except during an external data memory access.
$\overline{\text{EA}}$	51	49	I	<b>External access enable</b> When held high, the SAB 80C515 executes instructions from the internal ROM as long as the PC is less than 8192. When held low, the SAB 80C515 fetches all instructions from external program memory. For the SAB 80C535 this pin must be tied low.
P0.0-P0.7	52-59	52-59	I/O	<b>Port 0</b> is an 8-bit open-drain bidirectional I/O port. Port 0 pins that have 1's written to them float, and in that state can be used as high-impedance inputs. Port 0 is also the multiplexed low-order address and data bus during accesses to external program and data memory. In this application it uses strong internal pullup resistors when issuing 1's. Port 0 also outputs the code bytes during program verification in the SAB 80C515. External pullup resistors are required during program verification.

## Pin Definitions and Functions (cont'd)

Symbol	Pin P-LCC-68	Pin P-MQFP-80	Input (I) Output (O)	Function
P5.7-P5.0	60-67	60-67	I/O	<b>Port 5</b> is an 8-bit bidirectional I/O port with internal pullup resistors. Port 5 pins that have 1's written to them are pulled high by the internal pullup resistors, and in that state can be used as inputs. As inputs, port 5 pins being externally pulled low will source current ( $I_{IL}$ in the DC characteristics) because of the internal pullup resistors.
$V_{CC}$	37	33	—	<b>Supply voltage</b> during normal, idle, and power-down operation. Internally connected to pin 68.
$V_{SS}$	38	34	—	<b>Ground (0 V)</b>
$V_{CC}$	68	69	—	<b>Supply voltage</b> during normal, idle, and power-down operation. Internally connected to pin 37.
N. C.	—	2, 13, 14, 23, 32, 35, 46, 50, 51, 68, 70, 71	—	<b>Not connected</b> These pins of the P-MQFP-80 package must not be connected

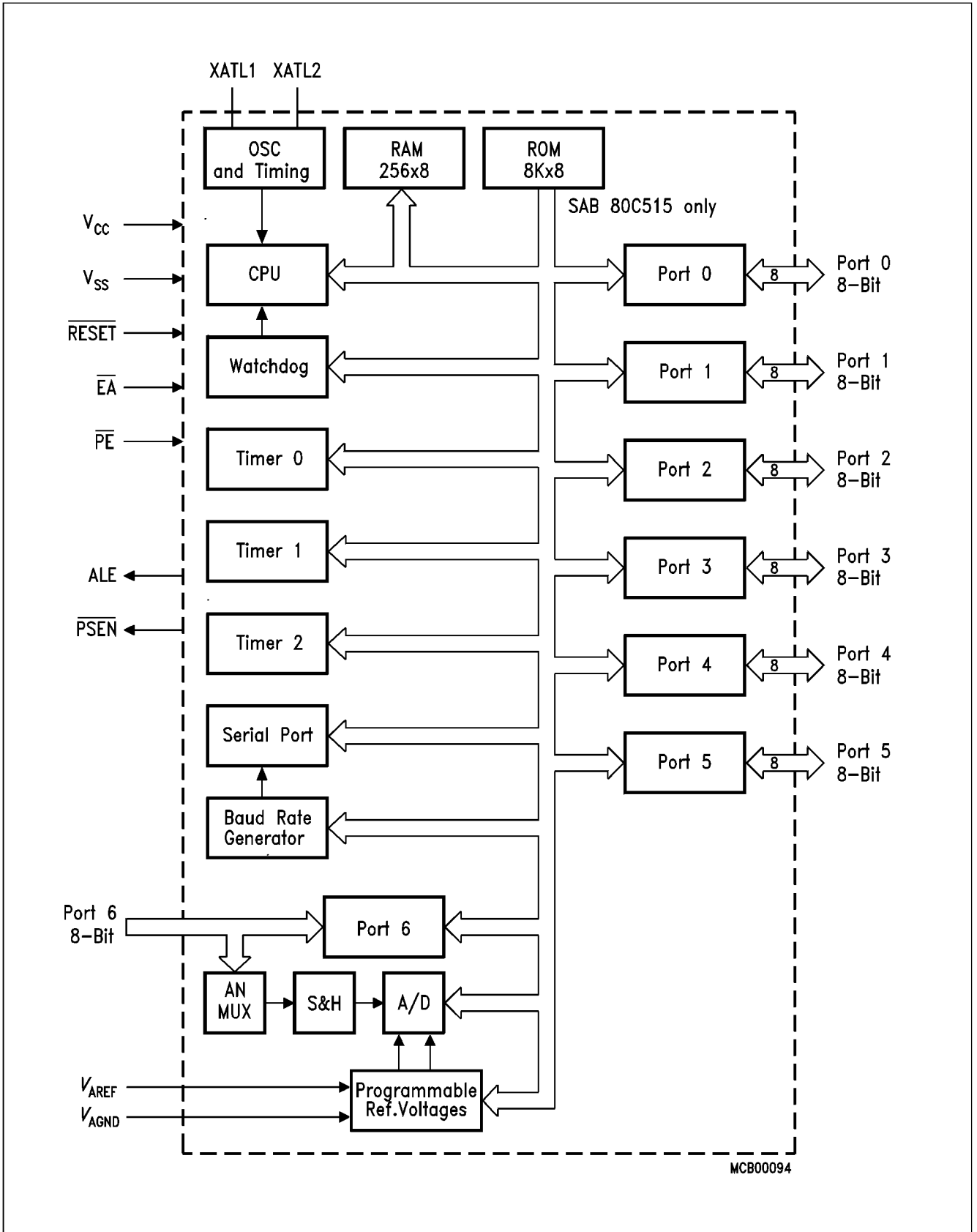

Figure 1  
Block Diagram

### Functional Description

The members of the SAB 80515 family of microcontrollers are:

- SAB 80C515: Microcontroller, designed in Siemens ACMOS technology, with 8 Kbyte factory mask-programmable ROM
- SAB 80C535: ROM-less version of the SAB 80C515
- SAB 80515: Microcontroller, designed in Siemens MYMOS technology, with 8 Kbyte factory mask-programmable ROM
- SAB 80535: ROM-less version of the SAB 80515

The SAB 80C535 is identical to the SAB 80C515, except that it lacks the on-chip ROM. In this data sheet the term "SAB 80C515" is used to refer to both the SAB 80C515 and SAB 80C535, unless otherwise noted.

### Principles of Architecture

The architecture of the SAB 80C515 is based on the SAB 8051/SAB 80C51 microcontroller family. The following features of the SAB 80C515 are fully compatible with the SAB 80C51 features:

- Instruction set
- External memory expansion interface (port 0 and port 2)
- Full-duplex serial port
- Timer/counter 0 and 1
- Alternate functions on port 3
- The lower 128 bytes of internal RAM and the lower 4 Kbytes of internal ROM

The SAB 80C515 additionally contains 128 bytes of internal RAM and 4 Kbytes of internal ROM, which results in a total of 256 bytes of RAM and 8 Kbytes of ROM on-chip.

The SAB 80C515 has a new 16-bit timer/counter with a 2:1 prescaler, reload mode, compare and capture capability. It also contains a 16-bit watchdog timer, an 8-bit A/D converter with programmable reference voltages, two additional quasi-bidirectional 8-bit ports, one 8-bit input port for analog or digital signals, and a programmable clock output ( $f_{OSC}/12$ ).

Furthermore, the SAB 80C515 has a powerful interrupt structure with 12 vectors and 4 programmable priority levels.

Figure 1 shows a block diagram of the SAB 80C515.

## **CPU**

The SAB 80C515 is efficient both as a controller and as an arithmetic processor. It has extensive facilities for binary and BCD arithmetic and excels in its bit-handling capabilities. Efficient use of program memory results from an instruction set consisting of 44 % one-byte, 41 % two-byte, and 15 % three-byte instructions. With a 12 MHz crystal, 58 % of the instructions execute in 1.0  $\mu$ s.

## **Memory Organization**

The SAB 80C515 manipulates operands in the four memory address spaces described below: Figure 1 illustrates the memory address spaces of the SAB 80C515.

### **Program Memory**

The SAB 80C515 has 8 Kbyte of on-chip ROM, while the SAB 80C535 has no internal ROM. The program memory can be externally expanded up to 64 Kbytes. If the  $\overline{EA}$  pin is held high, the SAB 80C515 executes out of internal ROM unless the address exceeds 1FFF<sub>H</sub>. Locations 2000<sub>H</sub> through 0FFFF<sub>H</sub> are then fetched from the external program memory. If the  $\overline{EA}$  pin is held low, the SAB 80C515 fetches all instructions from the external program memory. Since the SAB 80C535 has no internal ROM, pin  $\overline{EA}$  must be tied low when using this component.

### **Data Memory**

The data memory address space consists of an internal and an external memory space. The internal data memory is divided into three physically separate and distinct blocks: the lower 128 bytes of RAM, the upper 128 bytes of RAM, and the 128 byte special function register (SRF) area. While the upper 128 bytes of data memory and the SFR area share the same address locations, they are accessed through different addressing modes. The lower 128 bytes of data memory can be accessed through direct or register indirect addressing; the upper 128 bytes of RAM can be accessed through register indirect addressing; the special function registers are accessible through direct addressing.

Four 8-register banks, each bank consisting of eight 8-bit multi-purpose registers, occupy locations 0 through 1F<sub>H</sub> in the lower RAM area. The next 16 bytes, locations 20<sub>H</sub> through 2F<sub>H</sub>, contain 128 directly addressable bit locations. The stack can be located anywhere in the internal data memory address space, and the stack depth can be expanded up to 256 bytes.

The external data memory can be expanded up to 64 Kbytes and can be accessed by instructions that use a 16-bit or an 8-bit address.



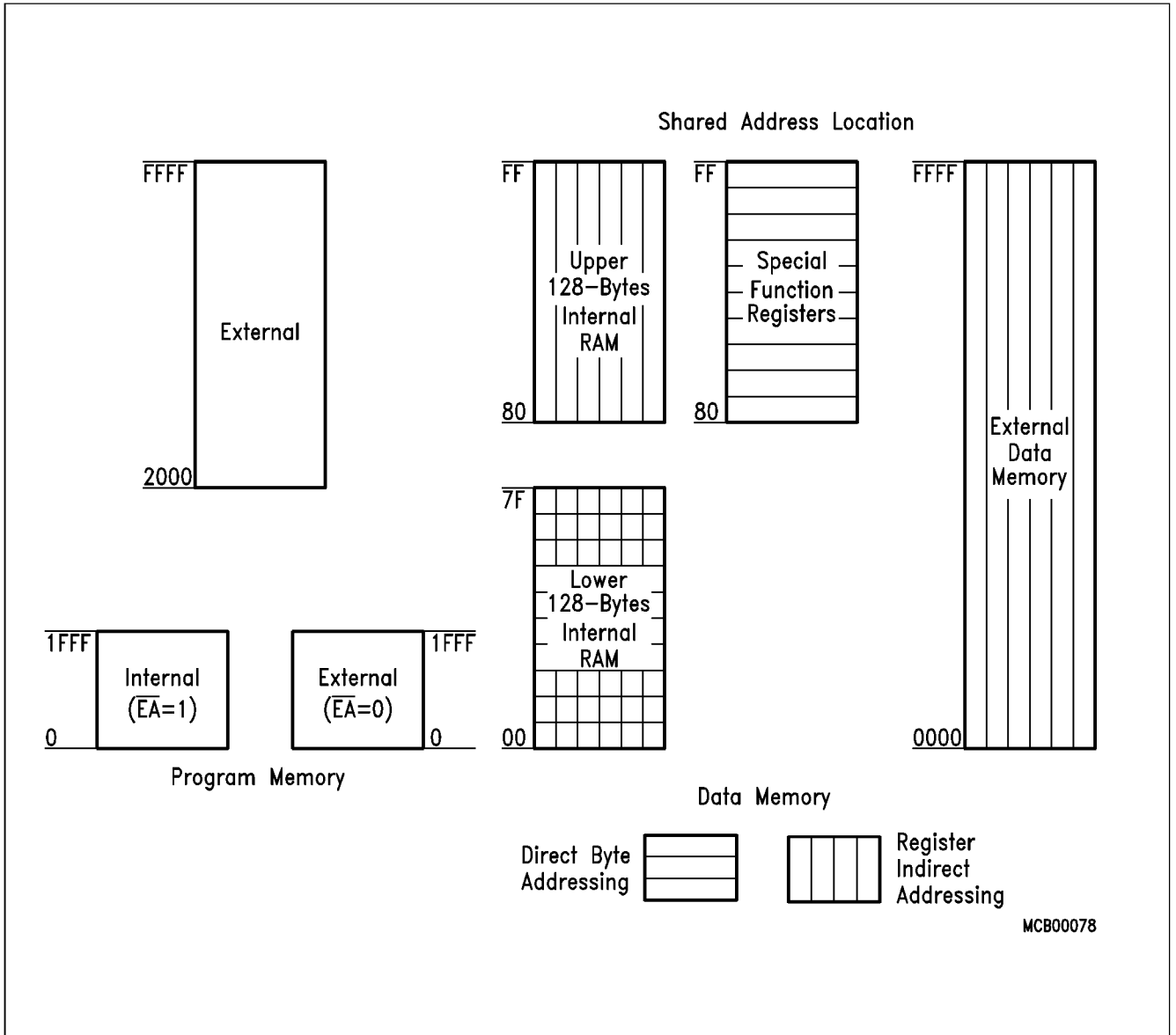

**Figure 2**  
Memory Address Spaces

## Special Function Registers

All registers, except the program counter and the four general purpose register banks, reside in the special function register area. The special function registers include arithmetic registers, pointers, and registers that provide an interface between the CPU and the on-chip peripherals. There are also 128 directly addressable bits within the SFR area. All special function registers are listed in table 1 and table 2.

In table 1 they are organized in numeric order of their addresses. In table 3 they are organized in groups which refer to the functional blocks of the SAB 80C515.

**Table 1**  
**Special Function Register**

Address	Register	Contents after Reset	Address	Register	Contents after Reset
<b>80<sub>H</sub></b>	<b>P0</b> <sup>1)</sup>	<b>0FF<sub>H</sub></b>	<b>98<sub>H</sub></b>	<b>SCON</b> <sup>1)</sup>	<b>00<sub>H</sub></b>
81 <sub>H</sub>	SP	07 <sub>H</sub>	99 <sub>H</sub>	SBUF	XX <sub>H</sub> <sup>2)</sup>
82 <sub>H</sub>	DPL	00 <sub>H</sub>	9A <sub>H</sub>	reserved	XX <sub>H</sub> <sup>2)</sup>
83 <sub>H</sub>	DPH	00 <sub>H</sub>	9B <sub>H</sub>	reserved	XX <sub>H</sub> <sup>2)</sup>
84 <sub>H</sub>	reserved	XX <sub>H</sub> <sup>2)</sup>	9C <sub>H</sub>	reserved	XX <sub>H</sub> <sup>2)</sup>
85 <sub>H</sub>	reserved	XX <sub>H</sub> <sup>2)</sup>	9D <sub>H</sub>	reserved	XX <sub>H</sub> <sup>2)</sup>
86 <sub>H</sub>	reserved	XX <sub>H</sub> <sup>2)</sup>	9E <sub>H</sub>	reserved	XX <sub>H</sub> <sup>2)</sup>
87 <sub>H</sub>	PCON	000X 0000 <sub>B</sub> <sup>2)</sup>	9F <sub>H</sub>	reserved	XX <sub>H</sub> <sup>2)</sup>
<b>88<sub>H</sub></b>	<b>TCON</b> <sup>1)</sup>	<b>00<sub>H</sub></b>	<b>A0<sub>H</sub></b>	<b>P2</b> <sup>1)</sup>	<b>0FF<sub>H</sub></b>
89 <sub>H</sub>	TMOD	00 <sub>H</sub>	A1 <sub>H</sub>	reserved	XX <sub>H</sub> <sup>2)</sup>
8A <sub>H</sub>	TL0	00 <sub>H</sub>	A2 <sub>H</sub>	reserved	XX <sub>H</sub> <sup>2)</sup>
8B <sub>H</sub>	TL1	00 <sub>H</sub>	A3 <sub>H</sub>	reserved	XX <sub>H</sub> <sup>2)</sup>
8C <sub>H</sub>	TH0	00 <sub>H</sub>	A4 <sub>H</sub>	reserved	XX <sub>H</sub> <sup>2)</sup>
8D <sub>H</sub>	TH1	00 <sub>H</sub>	A5 <sub>H</sub>	reserved	XX <sub>H</sub> <sup>2)</sup>
8E <sub>H</sub>	reserved	XX <sub>H</sub> <sup>2)</sup>	A6 <sub>H</sub>	reserved	XX <sub>H</sub> <sup>2)</sup>
8F <sub>H</sub>	reserved	XX <sub>H</sub> <sup>2)</sup>	A7 <sub>H</sub>	reserved	XX <sub>H</sub> <sup>2)</sup>
<b>90<sub>H</sub></b>	<b>P1</b> <sup>1)</sup>	<b>0FF<sub>H</sub></b>	<b>A8<sub>H</sub></b>	<b>IEN0</b> <sup>1)</sup>	<b>00<sub>H</sub></b>
91 <sub>H</sub>	reserved	XX <sub>H</sub> <sup>2)</sup>	A9 <sub>H</sub>	IP0	X000 0000 <sub>B</sub> <sup>2)</sup>
92 <sub>H</sub>	reserved	XX <sub>H</sub> <sup>2)</sup>	AA <sub>H</sub>	reserved	XX <sub>H</sub> <sup>2)</sup>
93 <sub>H</sub>	reserved	XX <sub>H</sub> <sup>2)</sup>	AB <sub>H</sub>	reserved	XX <sub>H</sub> <sup>2)</sup>
94 <sub>H</sub>	reserved	XX <sub>H</sub> <sup>2)</sup>	AC <sub>H</sub>	reserved	XX <sub>H</sub> <sup>2)</sup>
95 <sub>H</sub>	reserved	XX <sub>H</sub> <sup>2)</sup>	AD <sub>H</sub>	reserved	XX <sub>H</sub> <sup>2)</sup>
96 <sub>H</sub>	reserved	XX <sub>H</sub> <sup>2)</sup>	AE <sub>H</sub>	reserved	XX <sub>H</sub> <sup>2)</sup>
97 <sub>H</sub>	reserved	XX <sub>H</sub> <sup>2)</sup>	AF <sub>H</sub>	reserved	XX <sub>H</sub> <sup>2)</sup>

<sup>1)</sup> Bit-addressable Special Function Register

<sup>2)</sup> X means that the value is indeterminate and the location is reserved

**Table 1**  
**Special Function Register (cont'd)**

Address	Register	Contents after Reset	Address	Register	Contents after Reset
<b>B0<sub>H</sub></b> B1 <sub>H</sub> B2 <sub>H</sub> B3 <sub>H</sub> B4 <sub>H</sub> B5 <sub>H</sub> B6 <sub>H</sub> B7 <sub>H</sub>	<b>P3</b> <sup>1)</sup> reserved reserved reserved reserved reserved reserved reserved	<b>0FF<sub>H</sub></b> XX <sub>H</sub> <sup>2)</sup> XX <sub>H</sub> <sup>2)</sup> XX <sub>H</sub> <sup>2)</sup> XX <sub>H</sub> <sup>2)</sup> XX <sub>H</sub> <sup>2)</sup> XX <sub>H</sub> <sup>2)</sup> XX <sub>H</sub> <sup>2)</sup>	<b>D0<sub>H</sub></b> D1 <sub>H</sub> D2 <sub>H</sub> D3 <sub>H</sub> D4 <sub>H</sub> D5 <sub>H</sub> D6 <sub>H</sub> D7 <sub>H</sub>	<b>PSW</b> <sup>1)</sup> reserved reserved reserved reserved reserved reserved reserved	<b>00<sub>H</sub></b> XX <sub>H</sub> <sup>2)</sup> XX <sub>H</sub> <sup>2)</sup> XX <sub>H</sub> <sup>2)</sup> XX <sub>H</sub> <sup>2)</sup> XX <sub>H</sub> <sup>2)</sup> XX <sub>H</sub> <sup>2)</sup> XX <sub>H</sub> <sup>2)</sup>
<b>B8<sub>H</sub></b> B9 <sub>H</sub> BA <sub>H</sub> BB <sub>H</sub> BC <sub>H</sub> BD <sub>H</sub> BS <sub>H</sub> BF <sub>H</sub>	<b>IEN1</b> <sup>1)</sup> IP1 reserved reserved reserved reserved reserved reserved	<b>00<sub>H</sub></b> XX00 0000 <sub>B</sub> <sup>2)</sup> XX <sub>H</sub> <sup>2)</sup> XX <sub>H</sub> <sup>2)</sup> XX <sub>H</sub> <sup>2)</sup> XX <sub>H</sub> <sup>2)</sup> XX <sub>H</sub> <sup>2)</sup> XX <sub>H</sub> <sup>2)</sup>	<b>D8<sub>H</sub></b> D9 <sub>H</sub> DA <sub>H</sub> DB <sub>H</sub> DC <sub>H</sub> DD <sub>H</sub> DE <sub>H</sub> DF <sub>H</sub>	<b>ADCON</b> <sup>1)</sup> ADDAT DAPR P6 reserved reserved reserved reserved	<b>00X0 0000<sub>B</sub></b> <sup>2)</sup> 00 <sub>H</sub> 00 <sub>H</sub> XX <sub>H</sub> <sup>2)</sup> XX <sub>H</sub> <sup>2)</sup> XX <sub>H</sub> <sup>2)</sup> XX <sub>H</sub> <sup>2)</sup> XX <sub>H</sub> <sup>2)</sup>
<b>C0<sub>H</sub></b> C1 <sub>H</sub> C2 <sub>H</sub> C3 <sub>H</sub> C4 <sub>H</sub> C5 <sub>H</sub> C6 <sub>H</sub> C7 <sub>H</sub>	<b>IRCON</b> <sup>1)</sup> CCEN CCL1 CCH1 CCL2 CCH2 CCL3 CCH3	<b>00<sub>H</sub></b> 00 <sub>H</sub> 00 <sub>H</sub> 00 <sub>H</sub> 00 <sub>H</sub> 00 <sub>H</sub> 00 <sub>H</sub> 00 <sub>H</sub>	<b>E0<sub>H</sub></b> E1 <sub>H</sub> E2 <sub>H</sub> E3 <sub>H</sub> E4 <sub>H</sub> E5 <sub>H</sub> E6 <sub>H</sub> E7 <sub>H</sub>	<b>ACC</b> <sup>1)</sup> reserved reserved reserved reserved reserved reserved reserved	<b>00<sub>H</sub></b> XX <sub>H</sub> <sup>2)</sup> XX <sub>H</sub> <sup>2)</sup> XX <sub>H</sub> <sup>2)</sup> XX <sub>H</sub> <sup>2)</sup> XX <sub>H</sub> <sup>2)</sup> XX <sub>H</sub> <sup>2)</sup> XX <sub>H</sub> <sup>2)</sup>
<b>C8<sub>H</sub></b> C9 <sub>H</sub> CA <sub>H</sub> CB <sub>H</sub> CC <sub>H</sub> CD <sub>H</sub> CE <sub>H</sub> CF <sub>H</sub>	<b>T2CON</b> <sup>1)</sup> reserved CRCL CRCH TL2 TH2 reserved reserved	<b>00<sub>H</sub></b> XX <sub>H</sub> <sup>2)</sup> 00 <sub>H</sub> 00 <sub>H</sub> 00 <sub>H</sub> 00 <sub>H</sub> XX <sub>H</sub> <sup>2)</sup> XX <sub>H</sub> <sup>2)</sup>	<b>E8<sub>H</sub></b> E9 <sub>H</sub> EA <sub>H</sub> EB <sub>H</sub> EC <sub>H</sub> ED <sub>H</sub> EE <sub>H</sub> EF <sub>H</sub>	<b>P4</b> <sup>1)</sup> reserved reserved reserved reserved reserved reserved reserved	<b>0FF<sub>H</sub></b> XX <sub>H</sub> <sup>2)</sup> XX <sub>H</sub> <sup>2)</sup> XX <sub>H</sub> <sup>2)</sup> XX <sub>H</sub> <sup>2)</sup> XX <sub>H</sub> <sup>2)</sup> XX <sub>H</sub> <sup>2)</sup> XX <sub>H</sub> <sup>2)</sup>

<sup>1)</sup> Bit-addressable Special Function Register

<sup>2)</sup> X means that the value is indeterminate and the location is reserved

**Table 1**  
**Special Function Register (cont'd)**

Address	Register	Contents after Reset	Address	Register	Contents after Reset
<b>F0<sub>H</sub></b>	<b>B</b> <sup>1)</sup>	<b>00<sub>H</sub></b>	<b>F8<sub>H</sub></b>	<b>P5</b> <sup>1)</sup>	<b>0FF<sub>H</sub></b>
F1 <sub>H</sub>	reserved	XX <sub>H</sub> <sup>2)</sup>	F9 <sub>H</sub>	reserved	XX <sub>H</sub> <sup>2)</sup>
F2 <sub>H</sub>	reserved	XX <sub>H</sub> <sup>2)</sup>	FA <sub>H</sub>	reserved	XX <sub>H</sub> <sup>2)</sup>
F3 <sub>H</sub>	reserved	XX <sub>H</sub> <sup>2)</sup>	FB <sub>H</sub>	reserved	XX <sub>H</sub> <sup>2)</sup>
F4 <sub>H</sub>	reserved	XX <sub>H</sub> <sup>2)</sup>	FC <sub>H</sub>	reserved	XX <sub>H</sub> <sup>2)</sup>
F5 <sub>H</sub>	reserved	XX <sub>H</sub> <sup>2)</sup>	FD <sub>H</sub>	reserved	XX <sub>H</sub> <sup>2)</sup>
F6 <sub>H</sub>	reserved	XX <sub>H</sub> <sup>2)</sup>	FE <sub>H</sub>	reserved	XX <sub>H</sub> <sup>2)</sup>
F7 <sub>H</sub>	reserved	XX <sub>H</sub> <sup>2)</sup>	FF <sub>H</sub>	reserved	XX <sub>H</sub> <sup>2)</sup>

<sup>1)</sup> Bit-addressable Special Function Register

<sup>2)</sup> X means that the value is indeterminate and the location is reserved

**Table 2**  
**Special Function Registers - Functional Blocks**

Block	Symbol	Name	Address	Contents after Reset
CPU	ACC	Accumulator	<b>0E0<sub>H</sub></b> <sup>1)</sup>	00 <sub>H</sub>
	B	B-Register	<b>0F0<sub>H</sub></b> <sup>1)</sup>	00 <sub>H</sub>
	DPH	Data Pointer, High Byte	83 <sub>H</sub>	00 <sub>H</sub>
	DPL	Data Pointer, Low Byte	82 <sub>H</sub>	00 <sub>H</sub>
	PSW	Program Status Word Register	<b>0D0<sub>H</sub></b> <sup>1)</sup>	00 <sub>H</sub>
	SP	Stack Pointer	81 <sub>H</sub>	07 <sub>H</sub>
A/D-Converter	ADCON	A/D Converter Control Register	<b>0D8<sub>H</sub></b> <sup>1)</sup>	00X0 0000 <sub>B</sub> <sup>2)</sup>
	ADDAT	A/D Converter Data Register	0D9 <sub>H</sub>	00 <sub>H</sub>
	DAPR	D/A Converter Program Register	0DA <sub>H</sub>	00 <sub>H</sub>
Interrupt System	EN0	Interrupt Enable Register 0	<b>0A8<sub>H</sub></b> <sup>1)</sup>	00 <sub>H</sub>
	IEN1	Interrupt Enable Register 1	<b>0B8<sub>H</sub></b> <sup>1)</sup>	00 <sub>H</sub>
	IP0	Interrupt Priority Register 0	0A9 <sub>H</sub>	00 <sub>H</sub>
	IP1	Interrupt Priority Register 1	0B9 <sub>H</sub>	X000 0000 <sub>B</sub> <sup>2)</sup>
	IRCON	Interrupt Request Control Register	<b>0C0<sub>H</sub></b> <sup>1)</sup>	XX00 0000 <sub>B</sub> <sup>3)</sup>
	TCON <sup>2)</sup>	Timer Control Register	<b>88<sub>H</sub></b> <sup>1)</sup>	00 <sub>H</sub>
Compare/Capture-Unit (CCU)	T2CON <sup>2)</sup>	Timer 2 Control Register	<b>0C8<sub>H</sub></b> <sup>1)</sup>	00 <sub>H</sub>
	CCEN	Comp./Capture Enable Reg.	0C1 <sub>H</sub>	00 <sub>H</sub>
	CCH1	Comp./Capture Reg. 1, High Byte	0C3 <sub>H</sub>	00 <sub>H</sub>
	CCH2	Comp./Capture Reg. 2, High Byte	0C5 <sub>H</sub>	00 <sub>H</sub>
	CCH3	Comp./Capture Reg. 3, High Byte	0C7 <sub>H</sub>	00 <sub>H</sub>
	CCL1	Comp./Capture Reg. 1, Low Byte	0C2 <sub>H</sub>	00 <sub>H</sub>
	CCL2	Comp./Capture Reg. 2, Low Byte	0C4 <sub>H</sub>	00 <sub>H</sub>
	CCL3	Comp./Capture Reg. 3, Low Byte	0C6 <sub>H</sub>	00 <sub>H</sub>
	CRCH	Com./Rel./Capt. Reg. High Byte	0CB <sub>H</sub>	00 <sub>H</sub>
	CRCL	Com./Rel./Capt. Reg. Low Byte	0CA <sub>H</sub>	00 <sub>H</sub>
	TH2	Timer 2, High Byte	0CD <sub>H</sub>	00 <sub>H</sub>
	TL2	Timer 2, Low Byte	0CC <sub>H</sub>	00 <sub>H</sub>
	T2CON	Timer 2 Control Register	<b>0C8<sub>H</sub></b> <sup>1)</sup>	00 <sub>H</sub>

<sup>1)</sup> Bit-addressable special function registers

<sup>2)</sup> This special function register is listed repeatedly since some bits of it also belong to other functional blocks.

<sup>3)</sup> X means that the value is indeterminate and the location is reserved

**Table 2**  
**Special Function Registers- Functional Blocks (cont'd)**

Block	Symbol	Name	Address	Contents after Reset
Ports	P0	Port 0	<b>80<sub>H</sub></b> <sup>1)</sup>	0FF <sub>H</sub>
	P1	Port 1	<b>90<sub>H</sub></b> <sup>1)</sup>	0FF <sub>H</sub>
	P2	Port 2	<b>0A0<sub>H</sub></b> <sup>1)</sup>	0FF <sub>H</sub>
	P3	Port 3	<b>0B0<sub>H</sub></b> <sup>1)</sup>	0FF <sub>H</sub>
	P4	Port 4	<b>0E8<sub>H</sub></b> <sup>1)</sup>	0FF <sub>H</sub>
	P5	Port 5	<b>0F8<sub>H</sub></b> <sup>1)</sup>	0FF <sub>H</sub>
	P6	Port 6, Analog/Digital Input	0DB <sub>H</sub>	
Pow.Sav.Modes	PCON	Power Control Register	87 <sub>H</sub>	000X 0000 <sub>B</sub> <sup>2)</sup>
Serial Channels	ADCON <sup>2)</sup>	A/D Converter Control Reg.	<b>0D8<sub>H</sub></b> <sup>1)</sup>	00X0 0000 <sub>B</sub> <sup>2)</sup>
	PCON <sup>2)</sup>	Power Control Register	87 <sub>H</sub>	000X 0000 <sub>B</sub> <sup>2)</sup>
	SBUF	Serial Channel Buffer Reg.	99 <sub>H</sub>	0XX <sub>H</sub> <sup>3)</sup>
	SCON	Serial Channel Control Reg.	<b>98<sub>H</sub></b> <sup>1)</sup>	00 <sub>H</sub>
Timer 0/ Timer 1	TCON	Timer Control Register	<b>88<sub>H</sub></b> <sup>1)</sup>	00 <sub>H</sub>
	TH0	Timer 0, High Byte	8C <sub>H</sub>	00 <sub>H</sub>
	TH1	Timer 1, High Byte	8D <sub>H</sub>	00 <sub>H</sub>
	TL0	Timer 0, Low Byte	8A <sub>H</sub>	00 <sub>H</sub>
	TL1	Timer 1, Low Byte	8B <sub>H</sub>	00 <sub>H</sub>
	TMOD	Timer Mode Register	89 <sub>H</sub>	00 <sub>H</sub>
Watchdog	IEN0 <sup>2)</sup>	Interrupt Enable Register 0	<b>0A8<sub>H</sub></b> <sup>1)</sup>	00 <sub>H</sub>
	IEN1 <sup>2)</sup>	Interrupt Enable Register 1	<b>0B8<sub>H</sub></b> <sup>1)</sup>	00 <sub>H</sub>
	IP0 <sup>2)</sup>	Interrupt Priority Register 0	0A9 <sub>H</sub>	X000 0000 <sub>B</sub> <sup>2)</sup>
	IP1 <sup>2)</sup>	Interrupt Priority Register 1	0B9 <sub>H</sub>	XX00 0000 <sub>B</sub> <sup>3)</sup>

1) Bit-addressable special function registers

2) This special function register is listed repeatedly since some bits of it also belong to other functional blocks.

3) X means that the value is indeterminate and the location is reserved

**I/O Ports**

The SAB 80C515 has six 8-bit I/O ports and one 8-bit input port. Port 0 is an open-drain bidirectional I/O port, while ports 1 to 5 are quasi-bidirectional I/O ports with internal pullup resistors. That means, when configured as inputs, ports 1 to 5 will be pulled high and will source current when externally pulled low. Port 0 will float when configured as input.

Port 0 and port 2 can be used to expand the program and data memory externally. During an access to external memory, port 0 emits the low-order address byte and reads/writes the data byte, while port 2 emits the high-order address byte. In this function, port 0 is not an open-drain port, but uses a strong internal pullup FET. Ports 1 and 3 are provided for several alternate functions, as listed below:

Port	Symbol	Function
P1.0	$\overline{\text{INT3/CC0}}$	External interrupt 3 input, compare 0 output, capture 0 input
P1.1	INT4/CC1	External interrupt 4 input, compare 1 output, capture 1 input
P1.2	INT5/CC2	External interrupt 5 input, compare 2 output, capture 2 input
P1.3	$\overline{\text{INT6/CC3}}$	External interrupt 6 input, compare 3 output, capture 3 input
P1.4	$\overline{\text{INT2}}$	External interrupt 2 input
P1.5	T2EX	Timer 2 external reload trigger input
P1.6	CLKOUT	System clock output
P1.7	T2	Timer 2 external count or gate input
P3.0	RxD	Serial port's receiver data input (asynchronous) or data input/output (synchronous)
P3.1	TxD	Serial port's transmitter data output (asynchronous) or clock output (synchronous)
P3.2	$\overline{\text{INT0}}$	External interrupt 0 input, timer 0 gate control
P3.3	$\overline{\text{INT1}}$	External interrupt 1 input, timer 1 gate control
P3.4	T0	Timer 0 external counter input
P3.5	T1	Timer 1 external counter input
P3.6	$\overline{\text{WR}}$	External data memory write strobe
P3.7	RD	External data memory read strobe

The SAB 80C515 has dual-purpose input port. As the ANx lines in the SAB 80515 (NMOS version), the eight port lines at port 6 can be used as analog inputs. But if the input voltages at port 6 meet the specified digital input levels ( $V_{IL}$  and  $V_{IH}$ ), the port can also be used as digital input port. Reading the special function register P6 allows the user to input the digital values currently applied to the port pins. It is not necessary to select these modes by software; the voltages applied at port 6 pins can be converted to digital values using the A/D converter and at the same time the pins can be read via SFR P6.

It must be noted, however, that the results in port P6 bits will be indeterminate if the levels at the corresponding pins are not within their respective  $V_{IL}/V_{IH}$  specifications. Furthermore, it is not possible to use port P6 as output lines. Special function register P6 is located at address  $0DB_H$ .

### **Timer/Counters**

The SAB 80C515 contains three 16-bit timers/counters which are useful in many applications for timing and counting. The input clock for each timer/counter is 1/12 of the oscillator frequency in the timer operation or can be taken from an external clock source for the counter operation (maximum count rate is 1/24 of the oscillator frequency).

#### **– Timer/Counter 0 and 1**

These timers/counters can operate in four modes:

Mode 0: 8-bit timer/counter with 32:1 prescaler

Mode 1: 16-bit timer/counter

Mode 2: 8-bit timer/counter with 8-bit auto-reload

Mode 3: Timer/counter 0 is configured as one 8-bit timer/counter and one 8-bit timer; Timer/counter 1 in this mode holds its count.

External inputs  $\overline{\text{INT0}}$  and  $\overline{\text{INT1}}$  can be programmed to function as a gate for timer/counters 0 and 1 to facilitate pulse width measurements.

#### **– Timer/Counter 2**

Timer/counter 2 of the SAB 80C515 is a 16-bit timer/counter with several additional features. It offers a 2:1 prescaler, a selectable gate function, and compare, capture and reload functions. Corresponding to the 16-bit timer register there are four 16-bit capture/compare registers, one of them can be used to perform a 16-bit reload on a timer overflow or external event. Each of these registers corresponds to a pin of port 1 for capture input/compare output. Figure 3 shows a block diagram of timer/counter 2.

### **Reload**

A 16-bit reload can be performed with the 16-bit CRC register consisting of CRCL and CRCH. There are two modes from which to select:

Mode 0: Reload is caused by a timer 2 overflow (auto-reload).

Mode 1: Reload is caused in response to a negative transition at pin T2EX (P1.5), which can also request an interrupt.

### **Capture**

This feature permits saving the actual timer/counter contents into a selected register upon an external event or a software write operation. Two modes are provided to latch the current 16-bit value in timer 2 registers TL2 and TH2 into a dedicated capture register:

Mode 0: Capture is performed in response to a transition at the corresponding port 1 pins CC0 to CC3.

Mode 1: Write operation into the low-order byte of the dedicated capture register causes the timer 2 contents to be latched into this register.



**Compare**

In the compare mode, the 16-bit values stored in the dedicated compare registers are compared to the contents of the timer 2 registers. If the count value in the timer 2 registers matches one of the stored values, an appropriate output signal is generated and an interrupt is requested. Two compare modes are provided:

- Mode 0: Upon a match the output signal changes from low to high. It goes back to a low level when timer 2 overflows.
- Mode 1: The transition of the output signal can be determined by software. A timer 2 overflow causes no output change

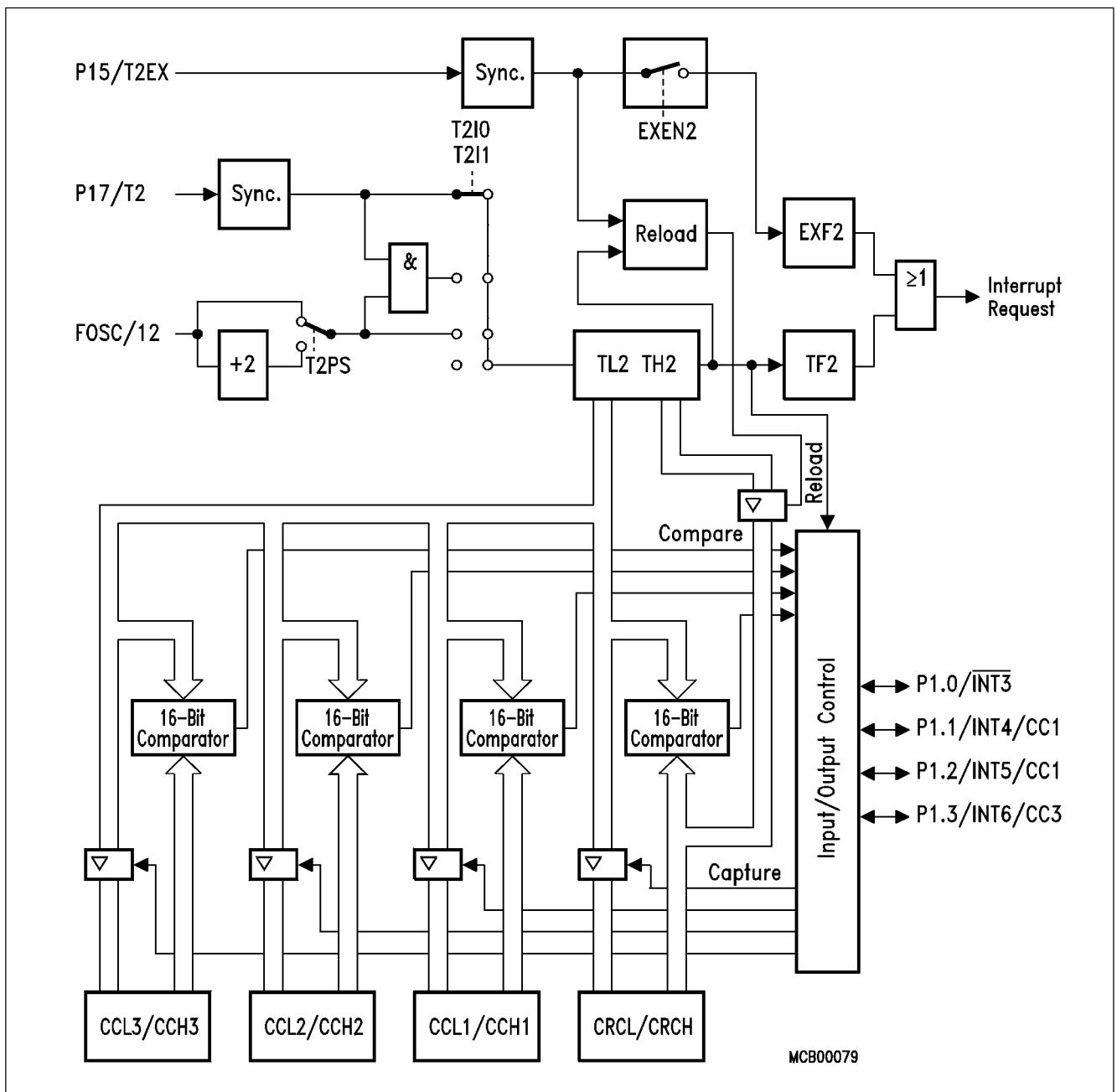

**Figure 3**  
**Block Diagram of Timer/Counter 2**

## Serial Port

The serial port of the SAB 80C515 enables full duplex communication between microcontrollers or between microcontroller and peripheral devices.

The serial port can operate in 4 modes:

- Mode 0: Shift register mode. Serial data enters and exits through RxD. TxD outputs the shift clock. 8-bits are transmitted/received: 8 data bits (LSB first).  
The baud rate is fixed at 1/12 of the oscillator frequency.
- Mode 1: 10-bits are transmitted (through RxD) or received (through TxD): a start bit (0), 8 data bits (LSB first), and a stop bit (1). The baud rate is variable.
- Mode 2: 11-bits are transmitted (through RxD) or received (through TxD): a start bit (0), 8 data bits (LSB first), a programmable 9th data bit, and a stop bit (1).  
The baud rate is programmable to either 1/32 or 1/64 of the oscillator frequency.
- Mode 3: 11-bits are transmitted (through TxD) or received (through RxD): a start bit (0), 8 data bits (LSB first), a programmable 9th data bit, and a stop bit (1). Mode 3 is identical to mode 2 except for the baud rate. The baud rate in mode 3 is variable.

The variable baud rates in modes 1 and 3 can be generated by timer 1 or an internal baud rate generator.

## A/D Converter

The 8-bit A/D converter of the SAB 80C515 has eight multiplexed analog inputs (Port 6) and uses the successive approximation method.

There are three characteristic time frames in a conversion cycle (see A/D converter characteristics): the conversion time  $t_C$ , which is the time required for one conversion; the sample time  $t_S$  which is included in the conversion time and is measured from the start of the conversion; the load time  $t_L$ , which in turn is part of the sample time and also is measured from the conversion start.

Within the load time  $t_L$ , the analog input capacitance  $C_I$  must be loaded to the analog input voltage level. For the rest of the sample time  $t_S$ , after the load time has passed, the selected analog input must be held constant. During the rest of the conversion time  $t_C$  the conversion itself is actually performed. Conversion can be programmed to be single or continuous; at the end of a conversion an interrupt can be generated.

A unique feature is the capability of internal reference voltage programming. The internal reference voltages  $V_{IntAREF}$  and  $V_{IntAGND}$  for the A/D converter both are programmable to one of 16 steps with respect to the external reference voltages. This feature permits a conversion with a smaller internal reference voltage range to gain a higher resolution.

In addition, the internal reference voltages can easily be adapted by software to the desired analog input voltage range.

Figure 4 shows a block diagram of the A/D converter.

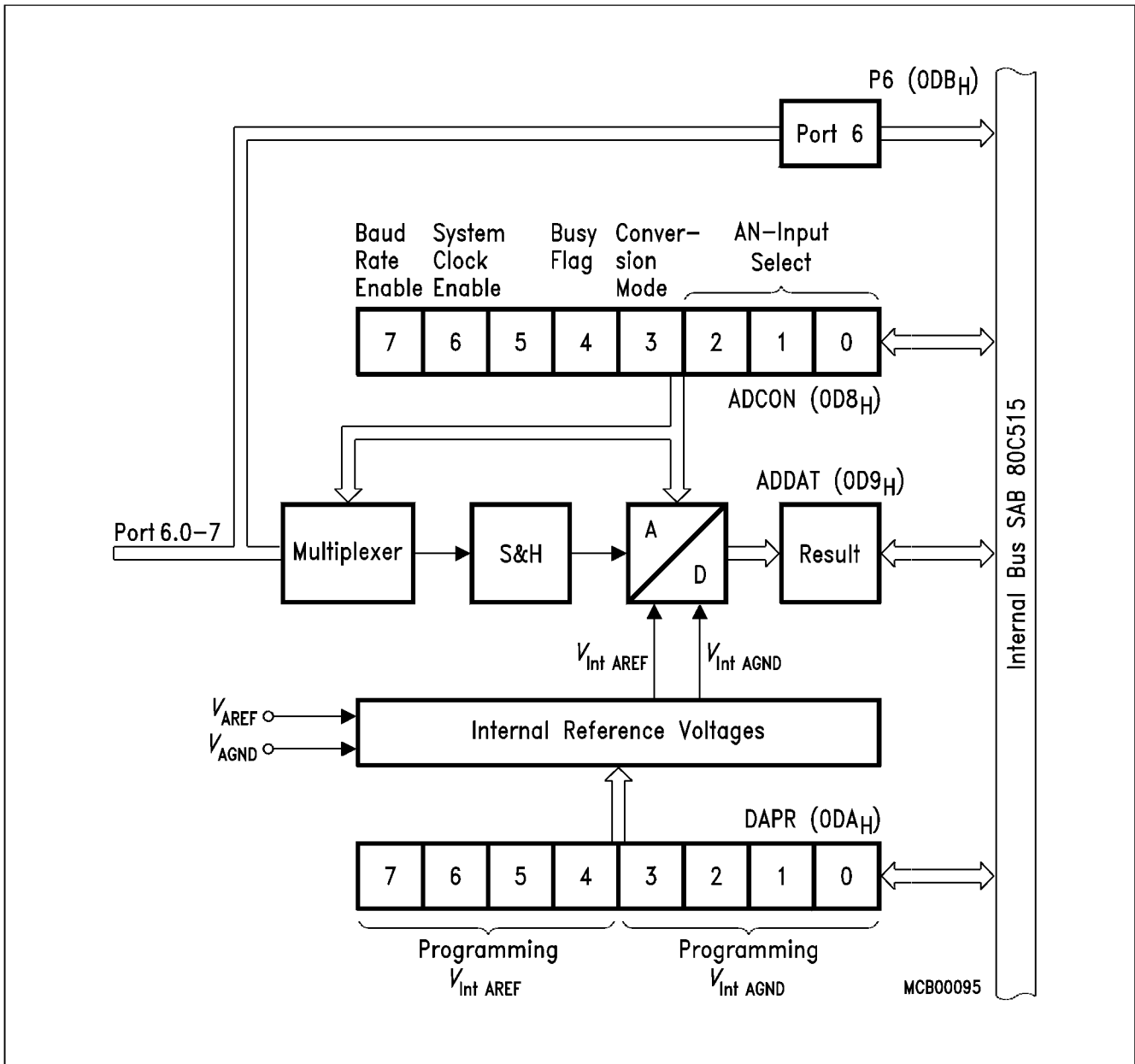

**Figure 4**  
**Block Diagram of the A/D Converter**

## Interrupt Structure

The SAB 80C515 has 12 interrupt vectors with the following vector addresses and request flags:

**Table 3**  
**Interrupt Sources and Vectors**

Source (Request Flags)	Vector Address	Vector
IE0	0003 <sub>H</sub>	External interrupt 0
TF0	000B <sub>H</sub>	Timer 0 interrupt
IE1	0013 <sub>H</sub>	External interrupt 1
TF1	001B <sub>H</sub>	Timer 1 interrupt
RI + TI	0023 <sub>H</sub>	Serial port interrupt
TF2 + EXF2	002B <sub>H</sub>	Timer 2 interrupt
IADC	0043 <sub>H</sub>	A/D converter interrupt
IEX2	004B <sub>H</sub>	External interrupt 2
IEX3	0053 <sub>H</sub>	External interrupt 3
IEX4	005B <sub>H</sub>	External interrupt 4
IEX5	0063 <sub>H</sub>	External interrupt 5
IEX6	006B <sub>H</sub>	External interrupt 6

Each interrupt vector can be individually enabled/disabled. The minimum response time to an interrupt request is more than 3 machine cycles and less than 9 machine cycles.

Figure 5 shows the interrupt request sources.

External interrupts 0 and 1 can be activated by a low-level or a negative transition (selectable) at their corresponding input pin, external interrupts 2 and 3 can be programmed for triggering on a negative or a positive transition. The external interrupts 3 or 6 are combined with the corresponding alternate functions compare (output) and capture (input) on port 1.

For programming of the priority levels the interrupt vectors are combined to pairs. Each pair can be programmed individually to one of four priority levels by setting or clearing one bit in the special function register IP0 and one in IP1.

Figure 6 shows the priority level structure.

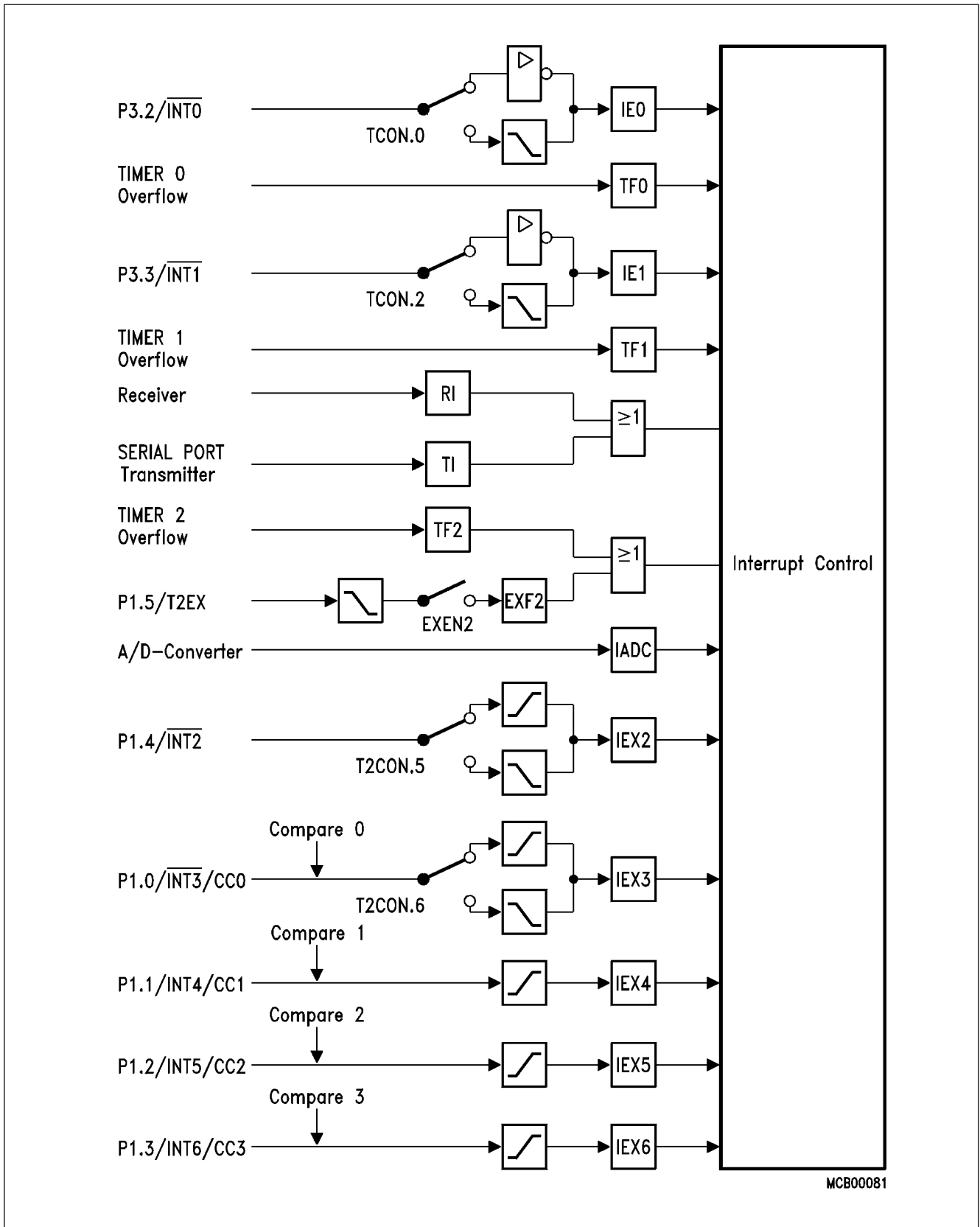

Figure 5  
Interrupt Request Sources

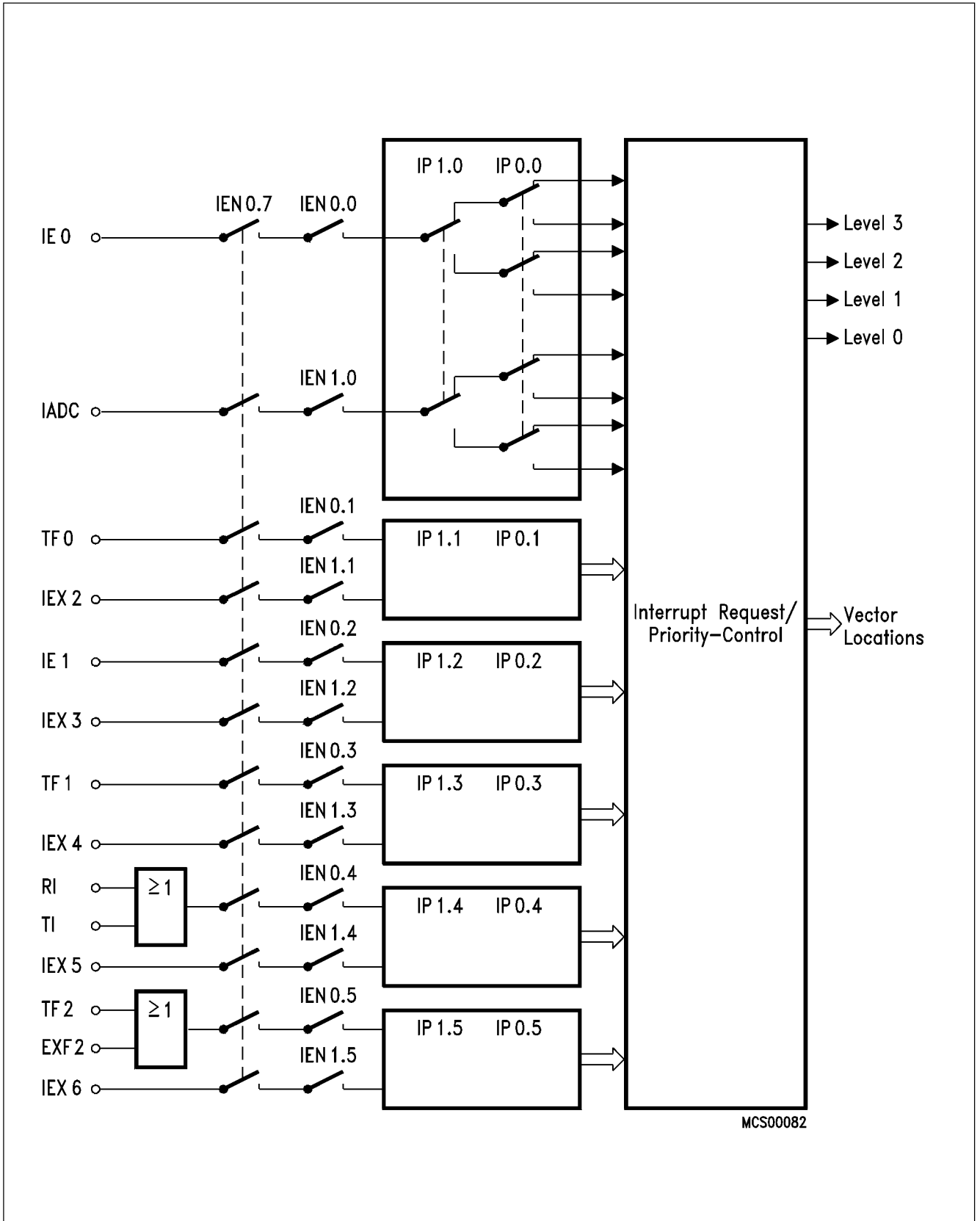

Figure 6  
Interrupt Priority Level Structure

### Watchdog Timer

This feature is provided as a means of graceful recovery from a software upset. After an external reset, the watchdog timer is cleared and stopped. It can be started and cleared by software, but it cannot be stopped during active mode of the device. If the software fails to clear the watchdog timer at least every 65532 machine cycles (about 65 ms if a 12 MHz oscillator frequency is used), an internal reset will be initiated. The reset cause (external reset or reset caused by the watchdog) can be examined by software. To clear the watchdog, two bits in two different special function registers must be set by two consecutive instructions (bits IEN0.6 and IEN1.6). This is done to prevent the watchdog from being cleared by unexpected opcodes.

It must be noted, however, that the watchdog timer is halted during the idle mode and power-down mode of the processor (see section "Power Saving Modes" below).

Therefore, it is possible to use the idle mode in combination with the watchdog timer function. But even the watchdog timer cannot reset the device when one of the power saving modes has been entered accidentally.

For these reasons several precautions are taken against unintentional entering of the power-down or idle mode (see below).

### Power Saving Modes

The ACMOS technology of the SAB 80C515 allows two new power saving modes of the device: The idle mode and the power-down mode. These modes replace the power-down supply mode via pin  $V_{PD}$  of the SAB 80515 (NMOS). The SAB 80C515 is supplied via pins  $V_{CC}$  also during idle and power-down operation.

However, there are applications where unintentional entering of these power saving modes must be absolutely avoided. Such critical applications often use the watchdog timer to prevent the system from program upsets. Then accidental entering of the power saving modes would even stop the watchdog timer and would circumvent the watchdog timer's task of system protection.

Thus, the SAB 80C515 has an extra pin that allows it to disable both of the power saving modes. When pin  $\overline{PE}$  is held high, idle mode and power-down mode are completely disabled and the instruction sequences that are used for entering these modes (see below) will NOT affect the normal operations of the device. When  $\overline{PE}$  is held low, the use of the idle mode and power-down mode is possible as described in the following sections.

Pin  $\overline{PE}$  has a weak internal pullup resistor. Thus, when left open, the power saving modes are disabled.

### The Special Function Register PCON

In the NMOS version SAB 80515 the SFR PCON (address 87<sub>H</sub>) contains only bit SMOD; in the CMOS version SAB 80C515 there are more bits used (see table 4).

The bits PDE, PDS and IDLE, IDLS select the power-down mode or the idle mode, respectively, when the use of the power saving modes is enabled by pin  $\overline{PE}$  (see next page).

If the power-down mode and the idle mode are set at the same time, power-down takes precedence.

Furthermore, register PCON contains two general purpose flags. For example, the flag bits GF0 and GF1 can be used to give an indication if an interrupt occurred during normal operation or during an idle. Then an instruction that activates Idle can also set one or both flag bits. When idle is terminated by an interrupt, the interrupt service routine can examine the flag bits.

The reset value of PCON is 000X0000<sub>B</sub>.

**Table 4**  
**SFR PCON (87H)**

SMOD	PDS	IDLS	–	GF1	GF0	PDE	IDLE	87H
7	6	5	4	3	2	1	0	

Symbol	Position	Function
SMOD	PCON.7	When set, the baud rate of the serial channel in mode 1, 2, 3 is doubled.
PDS	PCON.6	Power-down start bit. The instruction that sets the PDS flag bit is the last instruction before entering the power-down mode.
IDLS	PCON.5	Idle start bit. The instruction that sets the IDLS flag bit is the last instruction before entering the idle mode.
–	PCON.4	Reserved
GF1	PCON.3	General purpose flag
GF0	PCON.2	General purpose flag
PDE	PCON.1	Power-down enable bit. When set, starting of the power-down mode is enabled.
IDLE	PCON.0	Idle mode enable bit. When set, starting of the idle mode is enabled.

### Idle Mode

In the idle mode the oscillator of the SAB 80C515 continues to run, but the CPU is gated off from the clock signal. However, the interrupt system, the serial port, the A/D converter, and all timers with the exception of the watchdog timer are further provided with the clock. The CPU status is preserved in its entirety: the stack pointer, program counter, program status word, accumulator, and all other registers maintain their data during idle mode.

The reduction of power consumption, which can be achieved by this feature depends on the number of peripherals running.



If all timers are stopped and the A/D converter and the serial interface are not running, the maximum power reduction can be achieved. This state is also the test condition for the idle mode  $I_{CC}$  (see DC characteristics, note 5).

So the user has to take care which peripheral should continue to run and which has to be stopped during idle mode. Also the state of all port pins – either the pins controlled by their latches or controlled by their secondary functions – depends on the status of the controller when entering idle mode.

Normally the port pins hold the logical state they had at the time idle mode was activated. If some pins are programmed to serve their alternate functions they still continue to output during idle mode if the assigned function is on. This applies to the compare outputs as well as to the clock output signal or to the serial interface in case it cannot finish reception or transmission during normal operation. The control signals ALE and  $\overline{\text{PSEN}}$  hold at logic high levels (see table 5).

**Table 5**  
**Status of External Pins During Idle and Power-Down Mode**

Outputs	Last instruction executed from internal code memory		Last instruction executed from external code memory	
	Idle	Power-down	Idle	Power-down
ALE	High	Low	High	Low
PSEN	High	Low	High	Low
PORT 0	Data	Data	Float	Float
PORT 1	Data/alternate outputs	Data/last output	Data/alternate outputs	Data/last output
PORT 2	Data	Data	Address	Data
PORT 3	Data/alternate outputs	Data/last output	Data/alternate outputs	Data/last output
PORT 4	Data	Data	Data	Data
PORT 5	Data	Data	Data	Data

As in normal operation mode, the ports can be used as inputs during idle mode. Thus a capture or reload operation can be triggered, the timers can be used to count external events, and external interrupts will be detected.

The idle mode is a useful feature which makes it possible to "freeze" the processor's status – either for a predefined time, or until an external event reverts the controller to normal operation, as discussed below. The watchdog timer is the only peripheral which is automatically stopped during idle mode. If it were not disabled on entering idle mode, the watchdog timer would reset the controller, thus abandoning the idle mode.

When idle mode is used, pin  $\overline{PE}$  must be held on low level. The idle mode is then entered by two consecutive instructions. The first instruction sets the flag bit IDLE (PCON.0) and must not set bit IDLS (PCON.5), the following instruction sets the start bit IDLS (PCON.5) and must not set bit IDLE (PCON.0). The hardware ensures that a concurrent setting of both bits, IDLE and IDLS, does not initiate the idle mode. Bits IDLE and IDLS will automatically be cleared after being set. If one of these register bits is read the value that appears is 0 (see table 4). This double instruction is implemented to minimize the chance of an unintentional entering of the idle mode which would leave the watchdog timer's task of system protection without effect.

Note that PCON is not a bit-addressable register, so the above mentioned sequence for entering the idle mode is obtained by byte-handling instructions, as shown in the following example:

```
ORL    PCON,#00000001B    ;Set bit IDLE, bit IDLS must not be set
```

```
ORL    PCON,#00100000B    ;Set bit IDLS, bit IDLE must not be set
```

The instruction that sets bit IDLS is the last instruction executed before going into idle mode.

There are two ways to terminate the idle mode:

- The idle mode can be terminated by activating any enable interrupt. This interrupt will be serviced and normally the instruction to be executed following the RETI instruction will be the one following the instruction that sets the bit IDLS.
- The other way to terminate the idle mode, is a hardware reset. Since the oscillator is still running, the hardware reset must be held active only for two machine cycles for a complete reset.

### Power-Down Mode

In the power-down mode, the on-chip oscillator is stopped. Therefore all functions are stopped; only the contents of the on-chip RAM and the SFR's are maintained. The port pins controlled by their port latches output the values that are held by their SFR's.

The port pins which serve the alternate output functions show the values they had at the end of the last cycle of the instruction which initiated the power-down mode; when the clockout signal (CLKOUT, P1.6) is enabled, it will stop at low level. ALE and  $\overline{PSEN}$  hold at logic low level (see table 5).

To enter the power-down mode the pin  $\overline{PE}$  must be on low level. The power-down mode then is entered by two consecutive instructions. The first instruction has to set the flag bit PDE (PCON.1) and must not set bit PDS (PCON.6), the following instruction has to set the start bit PDS (PCON.6) and must not set bit PDE (PCON.1). The hardware ensures that a concurrent setting of both bits, PDE and PDS, does not initiate the power-down mode. Bits PDE and PDS will automatically be cleared after having been set and the value shown by reading one of these bits is always 0 (see table 4). This double instruction is implemented to minimize the chance of unintentionally entering the power-down mode which could possibly "freeze" the chip's activity in an undesired status.

Note that PCON is not a bit-addressable register, so the above mentioned sequence for entering the power-down mode is obtained by byte-handling instructions, as shown in the following example:

```
ORL    PCON,#00000010B ;Set bit PDE, bit PDS must not be set
```

```
ORL    PCON,#01000000B ;Set bit PDS, bit PDE must not be set
```

The instruction that sets bit PDS is the last instruction executed before going into power-down mode.

The only exit from power-down mode is a hardware reset. Reset will redefine all SFR's, but will not change the contents of the internal RAM.

In the power-down mode of operation,  $V_{CC}$  can be reduced to minimize power consumption. It must be ensured, however, that  $V_{CC}$  is not reduced before the power-down mode is invoked, and that  $V_{CC}$  is restored to its normal operating level, before the power-down mode is terminated. The reset signal that terminates the power-down mode also restarts the oscillator. The reset should not be activated before  $V_{CC}$  is restored to its normal operating level and must be held active long enough to allow the oscillator to restart and stabilize (similar to power-on reset).

### Differences in Pin Assignments of the SAB 80C515 and SAB 80515

Since the SAB 80C515 is designed in CMOS technology, this device requires no  $V_{BB}$  pin, because the die's substrate is internally connected to  $V_{CC}$ .

Furthermore, the RAM backup power supply via pin  $V_{PD}$  is replaced by the software-controlled power-down mode and power supply via  $V_{CC}$ .

Therefore, pins  $V_{BB}$  and  $V_{PD}$  of the NMOS version SAB 80515 are used for other functions in the SAB 80C515.

Pin 4 (the former pin  $V_{PD}$ ) is the new  $\overline{PE}$  pin which enables the use of the power saving modes.

Pin 37 (the former pin  $V_{BB}$ ) becomes an additional  $V_{CC}$  pin. Thus, it is possible to insert a decoupling capacitor between pin 37 ( $V_{CC}$ ) and pin 38 ( $V_{SS}$ ) very close to the device, thereby avoiding long wiring and reducing the voltage distortion resulting from high dynamic current peaks.

There is a difference between the NMOS and CMOS version concerning the clock circuitry. When the device is driven from an external source, pin XTAL2 must be driven by the clock signal; pin XTAL1, however, must be left open in the SAB 80C515 (must be tied low in the NMOS version). When using the oscillator with a crystal there is no difference in the circuitry.

Thus, due to its pin compatibility the SAB 80C515 normally substitutes any SAB 80515 without redesign of the user's printed circuit board, but the user has to take care that the two  $V_{CC}$  pins are hardwired on-chip. In any case, it is recommended that power is supplied on both  $V_{CC}$  pins of the SAB 80C515 to improve the power supply to the chip.

If the power saving modes are to be used, pin  $\overline{PE}$  must be tied low, otherwise these modes are disabled.

### Instruction Set

The SAB 80C515 / 83C535 has the same instruction set as the industry standard 8051 microcontroller.

A pocket guide is available which contains the complete instruction set in functional and hexadecimal order. Furtheron it provides helpful information about Special Function Registers, Interrupt Vectors and Assembler Directives.

### Literature Information

Title	Ordering No.
Microcontroller Family SAB 8051 Pocket Guide	B158-H6579-X-X-7600

**Absolute Maximum Ratings**

Ambient temperature under bias

SAB 80C515

0 to 70 °C

SAB 80C515-T3

– 40 to 85 °C

Storage temperature

– 65 to 150 °C

Voltage on  $V_{CC}$  pins with respect to ground ( $V_{SS}$ )

– 0.5 to 6.5 V

Voltage on any pin with respect to ground ( $V_{SS}$ )– 0.5 to  $V_{CC} + 0.5$  V

Input current on any pin during overload condition

– 10 mA to + 10 mA

Absolute sum of all input currents during overload condition

|100 mA|

Power dissipation

2 W

**Note** Stresses above those listed under "Absolute Maximum Ratings" may cause permanent damage of the device. This is a stress rating only and functional operation of the device at these or any other conditions above those indicated in the operational sections of this specification is not implied. Exposure to absolute maximum rating conditions for longer periods may affect device reliability. During overload conditions ( $V_{IN} > V_{CC}$  or  $V_{IN} < V_{SS}$ ) the Voltage on  $V_{CC}$  pins with respect to ground ( $V_{SS}$ ) must not exceed the values defined by the absolute maximum ratings.

**DC Characteristics** $V_{CC} = 5 \text{ V} \pm 10 \%$ ;  $V_{SS} = 0 \text{ V}$  $T_A = 0$  to 70 °C for the SAB 80C515/80C535 $T_A = -40$  to 85 °C for the SAB 80C515/80C535-T3

Parameter	Symbol	Limit values		Unit	Test condition
		min.	max.		
Input low voltage (except $\overline{EA}$ )	$V_{IL}$	– 0.5	$0.2 V_{CC}$ – 0.1	V	–
Input low voltage ( $\overline{EA}$ )	$V_{IL1}$	– 0.5	$0.2 V_{CC}$ – 0.3	V	–
Input high voltage (except $\overline{RESET}$ and XTAL <sup>2</sup> )	$V_{IH}$	$0.2 V_{CC}$ + 0.9	$V_{CC}$ + 0.5	V	–
Input high voltage to XTAL2	$V_{IH1}$	$0.7 V_{CC}$	$V_{CC}$ + 0.5	V	–
Input high voltage to $\overline{RESET}$	$V_{IH2}$	$0.6 V_{CC}$	$V_{CC}$ + 0.5	V	–
Output low voltage, ports 1, 2, 3, 4, 5	$V_{OL}$	–	– 0.45	V	$I_{OL} = 1.6 \text{ mA}$ <sup>1)</sup>

Notes see page 38.

## DC Characteristics (cont'd)

Parameter	Symbol	Limit values		Unit	Test condition
		min.	max.		
Output low voltage, port 0, ALE, PSEN	$V_{OL1}$	–	0.45	V	$I_{OL} = 3.2 \text{ mA } ^1)$
Output high voltage, ports 1, 2, 3, 4, 5	$V_{OH}$	2.4	–	V	$I_{OH} = -80 \mu\text{A}$
		$0.9 V_{CC}$	–	V	$I_{OH} = -10 \mu\text{A}$
Output high voltage (port 0 in external bus mode, ALE, PSEN)	$V_{OH1}$	2.4 $0.9 V_{CC}$	– –	V V	$I_{OH} = -400 \mu\text{A}$ $I_{OH} = -40 \mu\text{A } ^2)$
Logic 0 input current, ports 1, 2, 3, 4, 5	$I_{IL}$	– 10	– 70	$\mu\text{A}$	$V_{IN} = 0.45 \text{ V}$
Input low current to $\overline{\text{RESET}}$ for reset	$I_{IL2}$	– 10	– 100	$\mu\text{A}$	$V_{IN} = 0.45 \text{ V}$
Input low current ( $\overline{\text{XTAL2}}$ )	$I_{IL3}$	–	– 15	$\mu\text{A}$	$V_{IN} = 0.45 \text{ V}$
Input low current ( $\overline{\text{PE}}$ )	$I_{IL4}$	–	– 20	$\mu\text{A}$	$V_{IN} = 0.45 \text{ V}$
Logical 1-to-0 transition current, ports 1, 2, 3, 4, 5	$I_{TL}$	– 65	– 650	$\mu\text{A}$	$V_{IN} = 2 \text{ V}$
Input leakage current (port 0, port 6, AN0-7, EA)	$I_{LI}$	–	$\pm 1$	$\mu\text{A}$	$0.45 < V_{IN} < V_{CC}$
Pin capacitance	$C_{IO}$	–	10	pF	$f_C = 1 \text{ MHz}$ , $T_A = 25 \text{ }^\circ\text{C}$
Power-supply current:					
Active mode, 12 MHz <sup>6)</sup>	$-I_{CC}$	–	35	mA	$V_{CC} = 5 \text{ V } ^4)$
Idle mode, 12 MHz <sup>6)</sup>	$-I_{CC}$	–	13	mA	$V_{CC} = 5 \text{ V } ^5)$
Active mode, 16 MHz <sup>6)</sup>	$-I_{CC}$	–	46	mA	$V_{CC} = 5 \text{ V } ^4)$
Idle mode, 16 MHz <sup>6)</sup>	$-I_{CC}$	–	17	mA	$V_{CC} = 5 \text{ V } ^4)$
Power-down mode	$-I_{PD}$	–	50	$\mu\text{A}$	$V_{CC} = 5 \text{ V } ^5)$ $V_{CC} = 2 \text{ V to } 5.5 \text{ V } ^3)$

Notes see page 38.

**Notes** for page 36 and 37:

- 1) Capacitive loading on ports 0 and 2 may cause spurious noise pulses to be superimposed on the  $V_{OL}$  of ALE and ports 1, 3, 4 and 5. The noise is due to external bus capacitance discharging into the port 0 and port 2 pins when these pins make 1-to-0 transitions during bus operation.  
In the worst case (capacitive loading > 100 pF), the noise pulse on ALE line may exceed 0.8 V.  
Then, it may be desirable to qualify ALE with a Schmitttrigger, or use an address latch with a Schmitttrigger strobe input.
- 2) Capacitive loading on ports 0 and 2 may cause the VOH on ALE and PSEN to momentarily fall below the 0.9  $V_{CC}$  specification when the address bits are stabilizing.
- 3) Power-down  $I_{CC}$  is measured with:  $\overline{EA}$  = Port 0 = Port 6 =  $V_{CC}$ ;  
XTAL1 = N.C.; XTAL2 =  $V_{SS}$ ;  $\overline{RESET}$  =  $V_{CC}$ ;  $V_{AGND}$  =  $V_{SS}$ ; all other pins are disconnected.
- 4)  $I_{CC}$ (active mode) is measured with: XTAL2 driven with the clock signal according to the figure below; XTAL1 = N.C.; EA = Port 0 = Port 6 =  $V_{CC}$ ; RESET =  $V_{SS}$ ; all other pins are disconnected.  $I_{CC}$  might be slightly higher if a crystal oscillator is used.
- 5)  $I_{CC}$  (idle mode) is measured with: XTAL2 driven with the clock signal according to the figure below; XTAL1 = N.C.;  $\overline{EA}$  =  $V_{SS}$ ; Port 0 = Port 6  $V_{CC}$ ; RESET =  $V_{CC}$ ; all other pins are disconnected; all on-chip peripherals are disabled.
- 6)  $I_{CC}$  at other frequencies is given by:  
Active mode:  $I_{CC\ max} \text{ (mA)} = 2.67 \times f_{OSC} \text{ (MHz)} + 3.00$   
Idle mode:  $I_{CC\ max} \text{ (mA)} = 0.88 \times f_{OSC} \text{ (MHz)} + 2.50$   
where  $f_{OSC}$  is the oscillator frequency in MHz.  
 $I_{CC\ max}$  is given in mA and measured at  $V_{CC} = 5 \text{ V}$  (see also notes 4 and 5)

## A/D Converter Characteristics

$V_{CC} = 5\text{ V} \pm 10\%$ ;  $V_{SS} = 0\text{ V}$ ;  $V_{AREF} = V_{CC} \pm 5\%$ ;  $V_{AGND} = V_{SS} \pm 0.2\text{ V}$ ;  
 $V_{IntAREF} - V_{IntAGND} \geq 1\text{ V}$ ;  $T_A = 0\text{ to }70\text{ }^\circ\text{C}$  for SAB 80C515/80C535  
 $T_A = -40\text{ to }85\text{ }^\circ\text{C}$  for SAB 80C515/80C535-T40/85

Parameter	Symbol	Limit values			Unit	Test condition
		min.	typ.	max.		
Analog input voltage	$V_{AINPUT}$	$V_{AGND} - 0.2$	–	$V_{AREF} + 0.2$	V	9)
Analog input capacitance	$C_I$	–	25	45	pF	7)
Load time	$t_L$	–	–	$2 t_{CY}$	$\mu\text{s}$	–
Sample time (incl. load time)	$t_S$	–	–	$7 t_{CY}$	$\mu\text{s}$	–
Conversion time (incl. sample time)	$t_C$	–	–	$13 t_{CY}$	$\mu\text{s}$	–
Total unadjusted error	TUE	–	$\pm 1$	$\pm 2$	LSB	$V_{IntAREF} = V_{AREF} = V_{CC}$ $V_{IntAGND} = V_{AGND} = V_{SS}$ 7)
$V_{AREF}$ supply current	$I_{REF}$	–	–	5	mA	8)
Internal reference error	$V_{IntREFERR}$	–		$\pm 30$	mV	8)

7) The output impedance of the analog source must be low enough to assure full loading of the sample capacitance ( $C_I$ ) during load time ( $t_L$ ). After charging of the internal capacitance ( $C_I$ ) in the load time ( $t_L$ ) the analog input must be held constant for the rest of the sample time ( $t_S$ )

8) The differential impedance  $r_D$  of the analog reference voltage source must be less than  $1\text{ k}\Omega$  at reference supply voltage.

9) Exceeding these limit values at one or more input channels will cause additional current which is sunked / sourced at these channels. This may also affect the accuracy of other channels which are operated within these specifications.



**AC Characteristics**

$V_{CC} = 5\text{ V} \pm 10\%$ ;  $V_{SS} = 0\text{ V}$  ( $C_L$  for Port 0, ALE and  $\overline{\text{PSEN}}$  outputs = 100 pF;  
 $C_L$  for all outputs = 80 pF);  $T_A = 0$  to  $70\text{ }^\circ\text{C}$  for SAB 80C515/80C535  
 $T_A = -40$  to  $85\text{ }^\circ\text{C}$  for SAB 80C515/80C535-T40/85

Parameter	Symbol	Limit values				Unit
		12 MHz clock		Variable clock $1/t_{CLCL} = 3.5\text{ MHz to }12\text{ MHz}$		
		min.	max.	min.	max.	

**Program Memory Characteristics**

ALE pulse width	$t_{LHLL}$	127	–	$2 t_{CLCL} - 40$	–	ns
Address setup to ALE	$t_{AVLL}$	53	–	$t_{CLCL} - 30$	–	ns
Address hold after ALE	$t_{LLAX}$	48	–	$t_{CLCL} - 35$	–	ns
ALE to valid instruction in	$t_{LLIV}$	–	233	–	$4 t_{CLCL} - 100$	ns
ALE to $\overline{\text{PSEN}}$	$t_{LLPL}$	58	–	$t_{CLCL} - 25$	–	ns
$\overline{\text{PSEN}}$ pulse width	$t_{PLPH}$	215	–	$3 t_{CLCL} - 35$	–	ns
$\overline{\text{PSEN}}$ to valid instruction in	$t_{PLIV}$	–	150	–	$3 t_{CLCL} - 100$	ns
Input instruction hold after $\overline{\text{PSEN}}$	$t_{PXIX}$	0	–	0	–	ns
Input instruction float after $\overline{\text{PSEN}}$	$t_{PXIZ}^{1)}$	–	63	–	$t_{CLCL} - 20$	ns
Address valid after $\overline{\text{PSEN}}$	$t_{PXAV}^{1)}$	75	–	$t_{CLCL} - 8$	–	ns
Address to valid instruction in	$t_{AVIV}$	–	302	–	$5 t_{CLCL} - 115$	ns
Address float to $\overline{\text{PSEN}}$	$t_{AZPL}$	0	–	0	–	ns

<sup>1)</sup> Interfacing the SAB 80C515 to devices with float times up to 75 ns is permissible. This limited bus contention will not cause any damage to port 0 drivers.

## AC Characteristics (cont'd)

Parameter	Symbol	Limit values				Unit
		12 MHz clock		Variable clock $1/t_{CLCL} = 3.5 \text{ MHz to } 12 \text{ MHz}$		
		min.	max.	min.	max.	

## External Data Memory Characteristics

$\overline{RD}$ pulse width	$t_{RLRH}$	400	–	$6 t_{CLCL} - 100$	–	ns
$\overline{WR}$ pulse width	$t_{WLWH}$	400	–	$6 t_{CLCL} - 100$	–	ns
Address hold after ALE	$t_{LLAX2}$	132	–	$2 t_{CLCL} - 35$	–	ns
$\overline{RD}$ to valid data in	$t_{RLDV}$	–	252	–	$5 t_{CLCL} - 165$	ns
DATA hold after $\overline{RD}$	$t_{RHDX}$	0	–	0	–	ns
Data float after $\overline{RD}$	$t_{RHDZ}$	–	97	–	$2 t_{CLCL} - 70$	ns
ALE to valid data in	$t_{LLDV}$	–	517	–	$8 t_{CLCL} - 150$	ns
Address to valid data in	$t_{AVDV}$	–	585	–	$9 t_{CLCL} - 165$	ns
ALE to $\overline{WR}$ or $\overline{RD}$	$t_{LLWL}$	200	300	$3 t_{CLCL} - 50$	$3 t_{CLCL} + 50$	ns
$\overline{WR}$ or $\overline{RD}$ high to ALE high	$t_{WHLH}$	43	123	$t_{CLCL} - 40$	$t_{CLCL} + 40$	ns
Address valid to $\overline{WR}$	$t_{AVWL}$	203	–	$4 t_{CLCL} - 130$	–	ns
Data valid to $\overline{WR}$ transition	$t_{QVWX}$	33	–	$t_{CLCL} - 50$	–	ns
Data setup before $\overline{WR}$	$t_{QVWH}$	288	–	$7 t_{CLCL} - 150$	–	ns
Data hold after $\overline{WR}$	$t_{WHQX}$	13	–	$t_{CLCL} - 50$	–	ns
Address float after $\overline{RD}$	$t_{RLAZ}$	–	0	–	0	ns

**AC Characteristics (cont'd)**

Parameter	Symbol	Limit values		Unit
		Variable clock Frequ. = 3.5 MHz to 12 MHz		
		min.	max.	

**External Clock Drive**

Oscillator period	$t_{CLCL}$	83.3	285	ns
Oscillator frequency	$1/t_{CLCL}$	0.5	12	MHz
High time	$t_{CHCX}$	20	–	ns
Low time	$t_{CLCX}$	20	–	ns
Rise time	$t_{CLCH}$	–	20	ns
Fall time	$t_{CHCL}$	–	20	ns

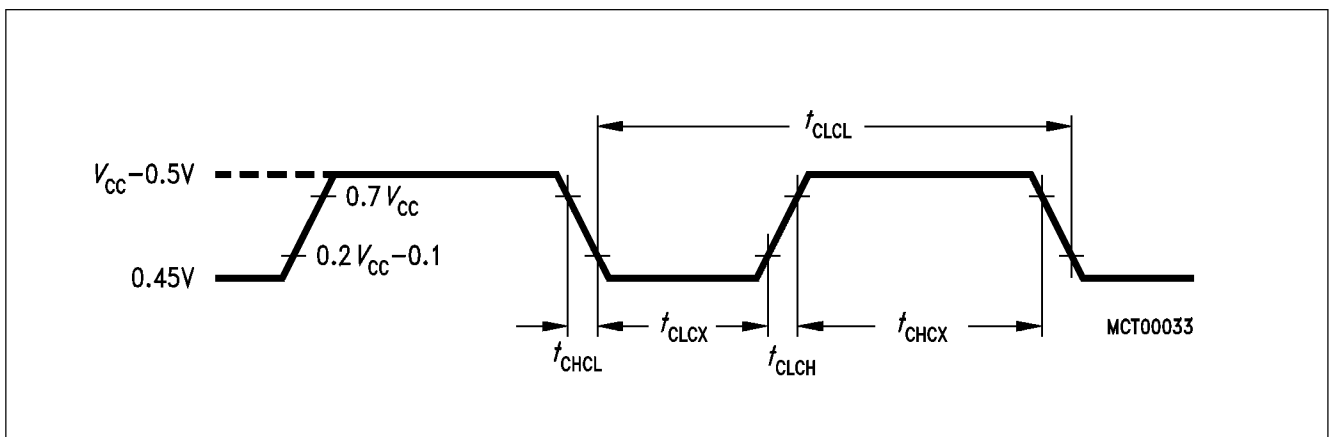

**External Clock Cycle**

## AC Characteristics (cont'd)

Parameter	Symbol	Limit values				Unit
		12 MHz clock		Variable clock $1/t_{CLCL} = 3.5 \text{ MHz to } 12 \text{ MHz}$		
		min.	max.	min.	max.	

## System Clock Timing

ALE to CLKOUT	$t_{LLSH}$	543	–	$7 t_{CLCL} - 40$	–	ns
CLKOUT high time	$t_{SHSL}$	127	–	$2 t_{CLCL} - 40$	–	ns
CLKOUT low time	$t_{SLSH}$	793	–	$10 t_{CLCL} - 40$	–	ns
CLKOUT low to ALE high	$t_{SLLH}$	43	123	$t_{CLCL} - 40$	$t_{CLCL} + 40$	ns

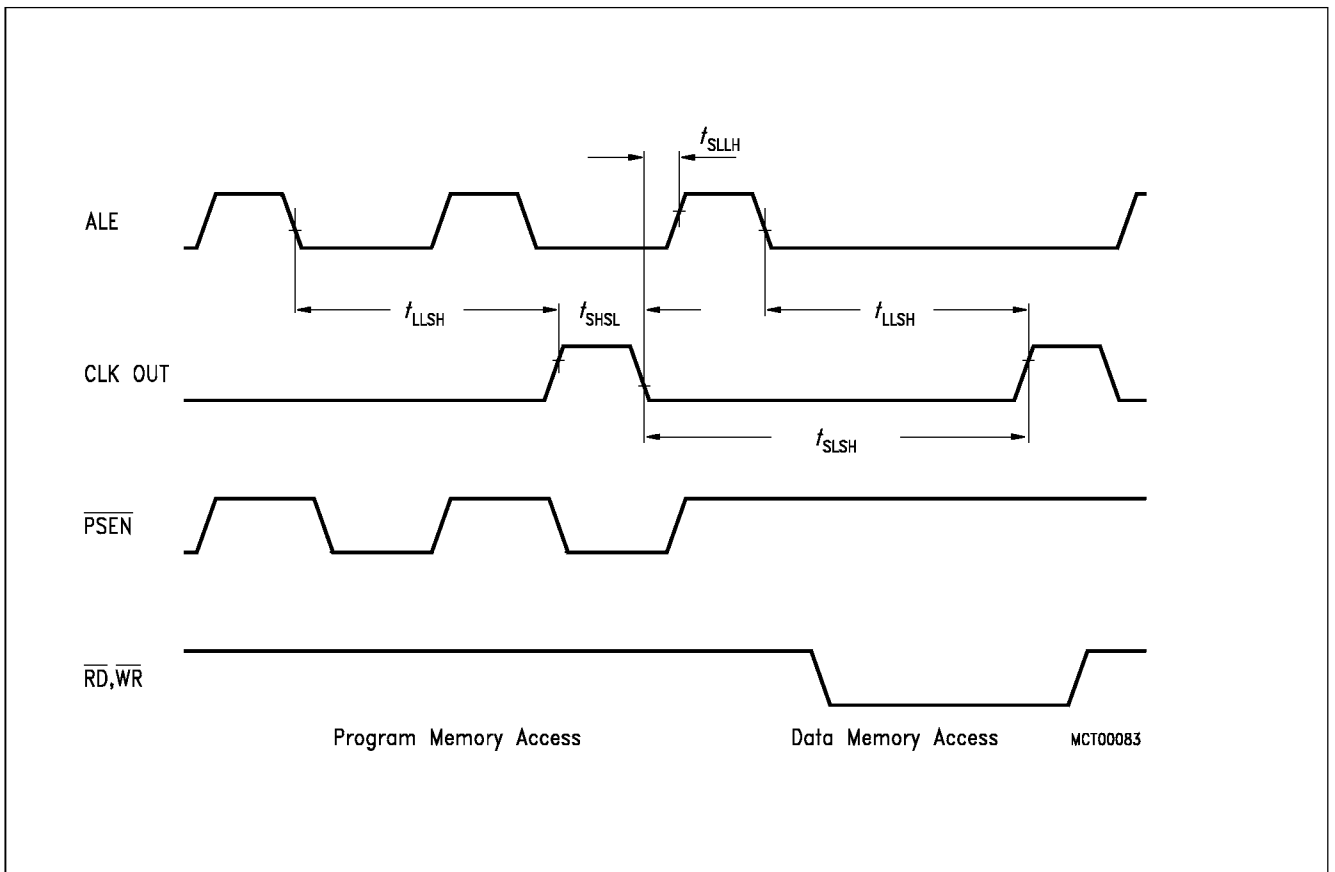

## System Clock Timing

**AC Characteristics for SAB 80C515-16/80C535-16**

$V_{CC} = 5\text{ V} \pm 10\%$ ;  $V_{SS} = 0\text{ V}$  ( $C_L$  for Port 0, ALE and  $\overline{\text{PSEN}}$  outputs = 100 pF;  
 $C_L$  for all outputs = 80 pF)       $T_A = 0\text{ to }70\text{ }^\circ\text{C}$  for SAB 80C515-16/80C535-16  
 $T_A = -40\text{ to }85\text{ }^\circ\text{C}$  for SAB 80C515-16/80C535-16-T40/85

Parameter	Symbol	Limit values				Unit
		16 MHz clock		Variable clock $1/t_{\text{CLCL}} = 3.5\text{ MHz to }16\text{ MHz}$		
		min.	max.	min.	max.	

**Program Memory Characteristics**

ALE pulse width	$t_{\text{LHLL}}$	85	–	$2 t_{\text{CLCL}} - 40$	–	ns
Address setup to ALE	$t_{\text{AVLL}}$	33	–	$t_{\text{CLCL}} - 30$	–	ns
Address hold after ALE	$t_{\text{LLAX}}$	28	–	$t_{\text{CLCL}} - 35$	–	ns
ALE to valid instruction in	$t_{\text{LLIV}}$	–	150	–	$4 t_{\text{CLCL}} - 100$	ns
ALE to $\overline{\text{PSEN}}$	$t_{\text{LLPL}}$	38	–	$t_{\text{CLCL}} - 25$	–	ns
$\overline{\text{PSEN}}$ pulse width	$t_{\text{PLPH}}$	153	–	$3 t_{\text{CLCL}} - 35$	–	ns
$\overline{\text{PSEN}}$ to valid instruction in	$t_{\text{PLIV}}$	–	88	–	$3 t_{\text{CLCL}} - 100$	ns
Input instruction hold after $\overline{\text{PSEN}}$	$t_{\text{PXIX}}$	0	–	0	–	ns
Input instruction float after $\overline{\text{PSEN}}$	$t_{\text{PXIZ}}^1)$	–	43	–	$t_{\text{CLCL}} - 20$	ns
Address valid after $\overline{\text{PSEN}}$	$t_{\text{PXAV}}^1)$	55	–	$t_{\text{CLCL}} - 8$	–	ns
Address to valid instruction in	$t_{\text{AVIV}}$	–	198	–	$5 t_{\text{CLCL}} - 115$	ns
Address float to $\overline{\text{PSEN}}$	$t_{\text{AZPL}}$	0	–	0	–	ns

<sup>1)</sup> Interfacing the SAB 80C515-16 to devices with float times up to 55 ns is permissible. This limited bus contention will not cause any damage to port 0 drivers.

## AC Characteristics (cont'd)

Parameter	Symbol	Limit values				Unit
		16 MHz clock		Variable clock $1/t_{CLCL} = 3.5 \text{ MHz to } 16 \text{ MHz}$		
		min.	max.	min.	max.	

## External Data Memory Characteristics

$\overline{RD}$ pulse width	$t_{RLRH}$	275	–	$6 t_{CLCL} - 100$	–	ns
$\overline{WR}$ pulse width	$t_{WLWH}$	275	–	$6 t_{CLCL} - 100$	–	ns
Address hold after ALE	$t_{LLAX2}$	90	–	$2 t_{CLCL} - 35$	–	ns
$\overline{RD}$ to valid data in	$t_{RLDV}$	–	148	–	$5 t_{CLCL} - 165$	ns
Data hold after $\overline{RD}$	$t_{RHDX}$	0	–	0	–	ns
Data float after $\overline{RD}$	$t_{RHDZ}$	–	55	–	$2 t_{CLCL} - 70$	ns
ALE to valid data in	$t_{LLDV}$	–	350	–	$8 t_{CLCL} - 150$	ns
Address to valid data in	$t_{AVDV}$	–	398	–	$9 t_{CLCL} - 165$	ns
ALE to $\overline{WR}$ or $\overline{RD}$	$t_{LLWL}$	138	238	$3 t_{CLCL} - 50$	$3 t_{CLCL} + 50$	ns
$\overline{WR}$ or $\overline{RD}$ high to ALE high	$t_{WHLH}$	23	103	$t_{CLCL} - 40$	$t_{CLCL} + 40$	ns
Address valid to $\overline{WR}$	$t_{AVWL}$	120	–	$4 t_{CLCL} - 130$	–	ns
Data valid to $\overline{WR}$ transition	$t_{QVWX}$	13	–	$t_{CLCL} - 50$	–	ns
Data setup before $\overline{WR}$	$t_{QVWH}$	288	–	$7 t_{CLCL} - 150$	–	ns
Data hold after $\overline{WR}$	$t_{WHQX}$	13	–	$t_{CLCL} - 50$	–	ns
Address float after $\overline{RD}$	$t_{RLAZ}$	–	0	–	0	ns

**AC Characteristics (cont'd)**

Parameter	Symbol	Limit values		Unit
		Variable clock Frequ. = 3.5 MHz to 16 MHz		
		min.	max.	

**External Clock Drive**

Oscillator period	$t_{CLCL}$	62.5	285	ns
Oscillator frequency	$1/t_{CLCL}$	0.5	16	MHz
High time	$t_{CHCX}$	15	-	ns
Low time	$t_{CLCX}$	15	-	ns
Rise time	$t_{CLCH}$	-	15	ns
Fall time	$t_{CHCL}$	-	15	ns

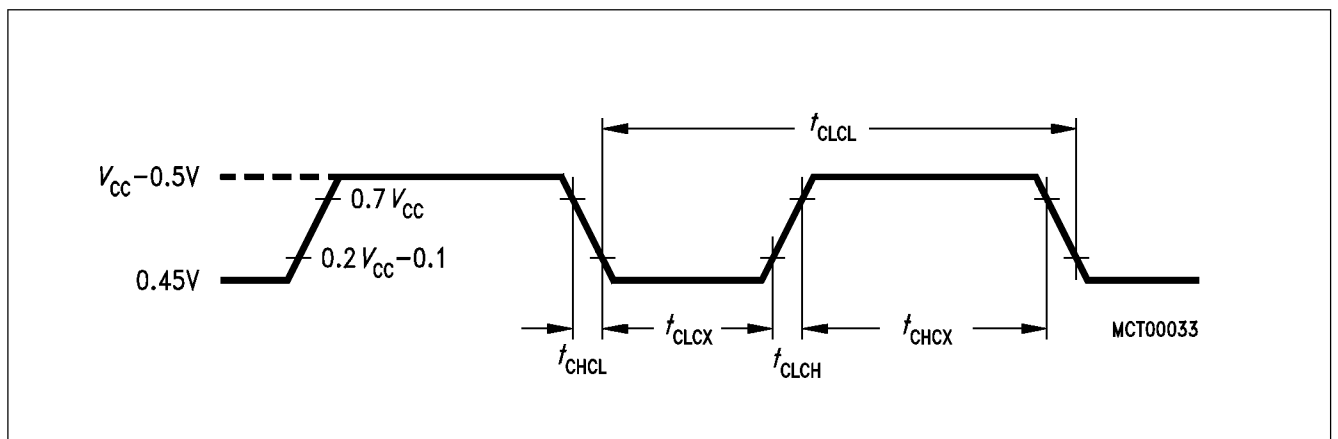

**External Clock Cycle**

## AC Characteristics (cont'd)

Parameter	Symbol	Limit values				Unit
		16 MHz clock		Variable clock $1/t_{CLCL} = 3.5 \text{ MHz to } 16 \text{ MHz}$		
		min.	max.	min.	max.	

## System Clock Timing

ALE to CLK OUT	$t_{LLSH}$	398	—	$7 t_{CLCL} - 40$	—	ns
CLK OUT high time	$t_{SHSL}$	85	—	$2 t_{CLCL} - 40$	—	ns
CLK OUT low time	$t_{SLSH}$	585	—	$10 t_{CLCL} - 40$	—	ns
CLK OUT low to ALE high	$t_{SLLH}$	23	103	$t_{CLCL} - 40$	$t_{CLCL} + 40$	ns

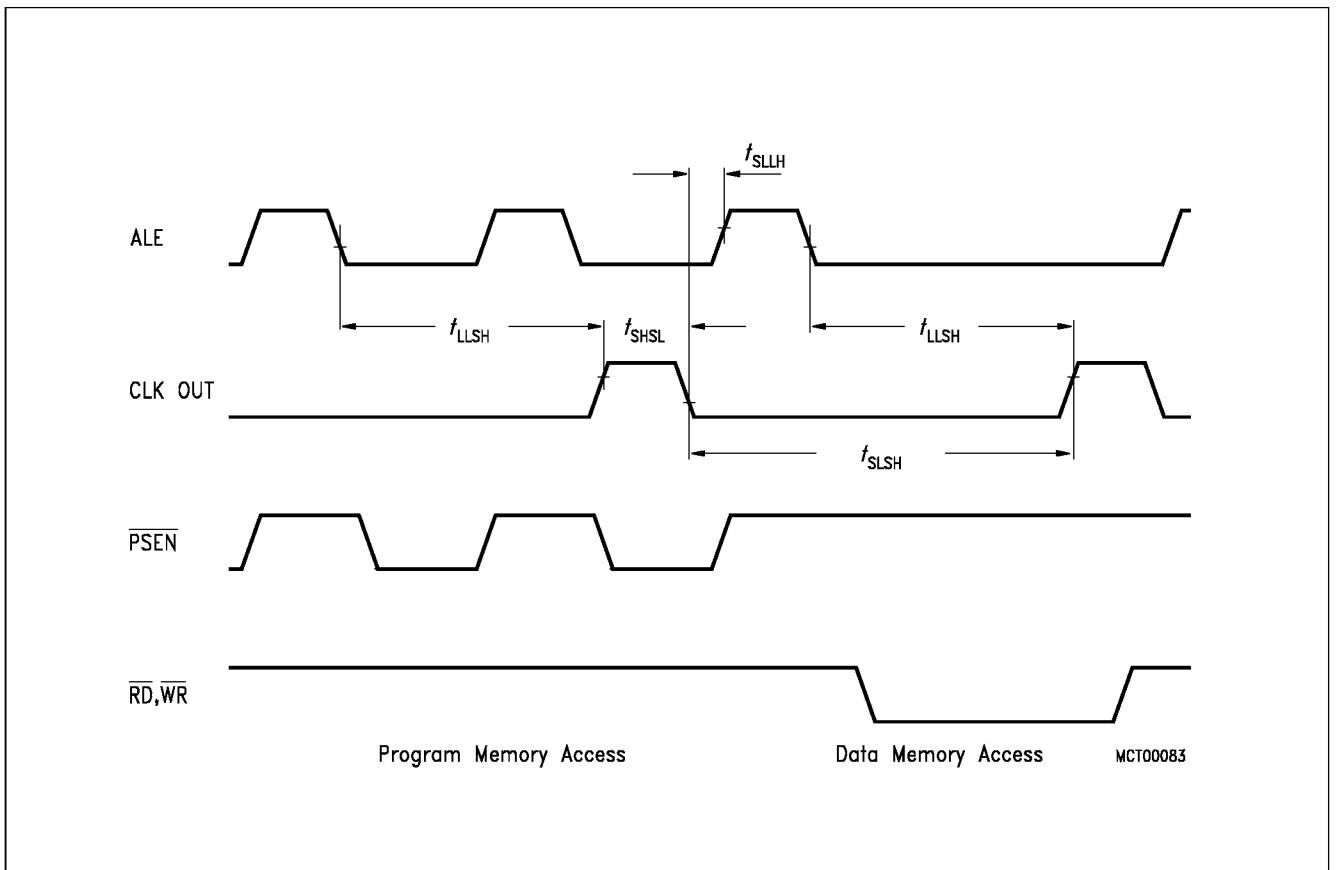

## System Clock Timing



**AC Characteristics for SAB 80C515-20 / 80C535-20**

$V_{CC} = 5\text{ V} \pm 10\%$ ;  $V_{SS} = 0\text{ V}$   $T_A = 0\text{ }^\circ\text{C}$  to  $+70\text{ }^\circ\text{C}$   
 ( $C_L$  for port 0, ALE and  $\overline{\text{PSEN}}$  outputs = 100 pF;  $C_L$  for all other outputs = 80 pF)

Parameter	Symbol	Limit values				Unit
		20 MHz clock		Variable clock $1/t_{\text{CLCL}} = 3.5\text{ MHz to }20\text{ MHz}$		
		min.	max.	min.	max.	

**Program Memory Characteristics**

ALE pulse width	$t_{\text{LHLL}}$	60	–	$2 t_{\text{CLCL}} - 40$	–	ns
Address setup to ALE	$t_{\text{AVLL}}$	20	–	$t_{\text{CLCL}} - 30$	–	ns
Address hold after ALE	$t_{\text{LLAX}}$	20	–	$t_{\text{CLCL}} - 30$	–	ns
ALE low to valid instr in	$t_{\text{LLIV}}$	–	100	–	$4 t_{\text{CLCL}} - 100$	ns
ALE to $\overline{\text{PSEN}}$	$t_{\text{LLPL}}$	25	–	$t_{\text{CLCL}} - 25$	–	ns
$\overline{\text{PSEN}}$ pulse width	$t_{\text{PLPH}}$	115	–	$3 t_{\text{CLCL}} - 35$	–	ns
$\overline{\text{PSEN}}$ to valid instr in	$t_{\text{PLIV}}$	–	75	–	$3 t_{\text{CLCL}} - 75$	ns
Input instruction hold after $\overline{\text{PSEN}}$	$t_{\text{PXIX}}$	0	–	0	–	ns
Input instruction float after $\overline{\text{PSEN}}$	$t_{\text{PXIZ}}^{*)}$	–	40	–	$t_{\text{CLCL}} - 10$	ns
Address valid after $\overline{\text{PSEN}}$	$t_{\text{PXAV}}^{*)}$	47	–	$t_{\text{CLCL}} - 3$	–	ns
Address to valid instr in	$t_{\text{AVIV}}$	–	190	–	$5 t_{\text{CLCL}} - 60$	ns
Address float to $\overline{\text{PSEN}}$	$t_{\text{AZPL}}$	0	–	0	–	ns

\*) Interfacing the SAB 80C515 / 80C535 microcontrollers to devices with float times up to 45 ns is permissible. This limited bus contention will not cause any damage to port 0 drivers.

## AC Characteristics (cont'd)

Parameter	Symbol	Limit values				Unit
		20 MHz clock		Variable clock $1/t_{CLCL} = 3.5 \text{ MHz to } 20 \text{ MHz}$		
		min.	max.	min.	max.	

## External Data Memory Characteristics

$\overline{RD}$ pulse width	$t_{RLRH}$	200	–	$6 t_{CLCL} - 100$	–	ns
$\overline{WR}$ pulse width	$t_{WLWH}$	200	–	$6 t_{CLCL} - 100$	–	ns
Address hold after ALE	$t_{LLAX2}$	65	–	$2 t_{CLCL} - 35$	–	ns
$\overline{RD}$ to valid data in	$t_{RLDV}$	–	155	–	$5 t_{CLCL} - 95$	ns
Data hold after $\overline{RD}$	$t_{RHDX}$	0	–	0	–	ns
Data float after $\overline{RD}$	$t_{RHDZ}$	–	40	–	$2 t_{CLCL} - 60$	ns
ALE to valid data in	$t_{LLDV}$	–	250	–	$8 t_{CLCL} - 150$	ns
Address to valid data in	$t_{AVDV}$	–	285	–	$9 t_{CLCL} - 165$	ns
ALE to $\overline{WR}$ or $\overline{RD}$	$t_{LLWL}$	100	200	$3 t_{CLCL} - 50$	$3 t_{CLCL} + 50$	ns
Address valid to $\overline{WR}$ or $\overline{RD}$	$t_{AVWL}$	70	–	$4 t_{CLCL} - 130$	–	ns
$\overline{WR}$ or $\overline{RD}$ high to ALE high	$t_{WHLH}$	20	80	$t_{CLCL} - 30$	$t_{CLCL} + 30$	ns
Data valid to $\overline{WR}$ transition	$t_{QVWX}$	5	–	$t_{CLCL} - 45$	–	ns
Data setup before $\overline{WR}$	$t_{QVWH}$	200	–	$7 t_{CLCL} - 150$	–	ns
Data hold after $\overline{WR}$	$t_{WHQX}$	10	–	$t_{CLCL} - 40$	–	ns
Address float after $\overline{RD}$	$t_{RLAZ}$	–	0	–	0	ns

**AC Characteristics (cont'd)**

Parameter	Symbol	Limit Values		Unit
		Variable clock $1/t_{CLCL} = 3.5 \text{ MHz to } 20 \text{ MHz}$		
		min.	max.	

**External Clock Drive**

Oscillator period	$t_{CLCL}$	50	285	ns
High time	$t_{CHCX}$	12	$t_{CLCL} - t_{CLCX}$	ns
Low time	$t_{CLGX}$	12	$t_{CLCL} - t_{CHCX}$	ns
Rise time	$t_{CLCH}$	–	12	ns
Fall time	$t_{CHCL}$	–	12	ns

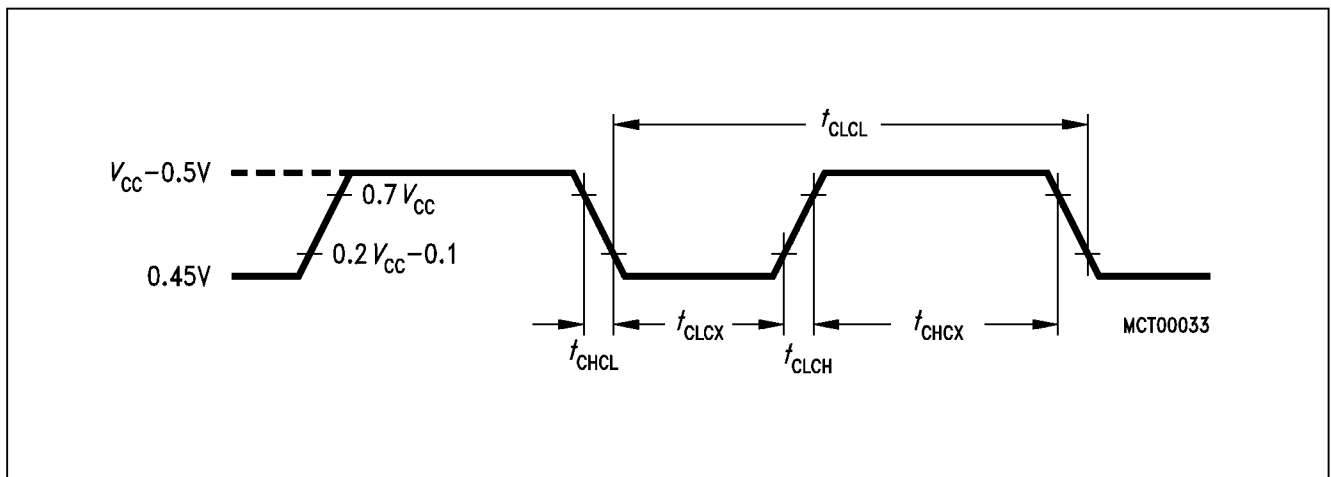

**External Clock Cycle**

## AC Characteristics (cont'd)

Parameter	Symbol	Limit values				Unit
		20 MHz clock		Variable clock $1/t_{CLCL} = 3.5 \text{ MHz to } 20 \text{ MHz}$		
		min.	max.	min.	max.	

### System Clock Timing

ALE to CLKOUT	$t_{LLSH}$	310	—	$7 t_{CLCL} - 40$	—	ns
CLKOUT high time	$t_{SHSL}$	60	—	$2 t_{CLCL} - 40$	—	ns
CLKOUT low time	$t_{SLSH}$	460	—	$10 t_{CLCL} - 40$	—	ns
CLKOUT low to ALE high	$t_{SLLH}$	10	90	$t_{CLCL} - 40$	$t_{CLCL} + 40$	ns

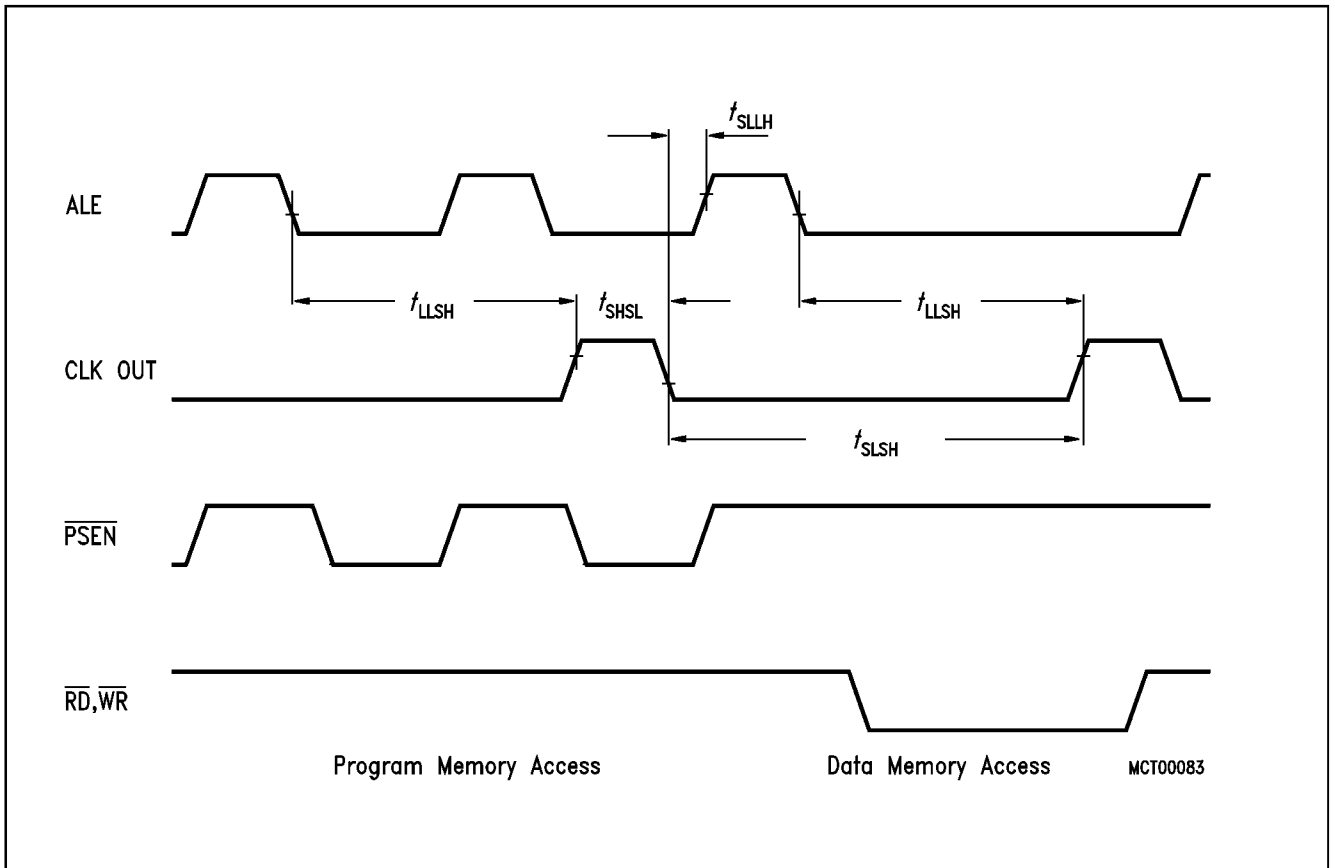

### External Clock Cycle

**ROM Verification Characteristics**

$T_A = 25\text{ }^\circ\text{C} \pm 5\text{ }^\circ\text{C}$ ;  $V_{CC} = 5\text{ V} \pm 10\%$ ;  $V_{SS} = 0\text{ V}$

Parameter	Symbol	Limit values		Unit
		min.	max.	

**ROM Verification**

Address to valid data	$t_{AVQV}$	-	$48 t_{CLCL}$	ns
ENABLE to valid data	$t_{ELQV}$	-	$48 t_{CLCL}$	ns
Data float after ENABLE	$t_{EHOZ}$	0	$48 t_{CLCL}$	ns
Oscillator frequency	$1/t_{CLCL1}$	4	6	MHz
Address to valid data	$t_{AVQV}$	-	$48 t_{CLCL}$	ns

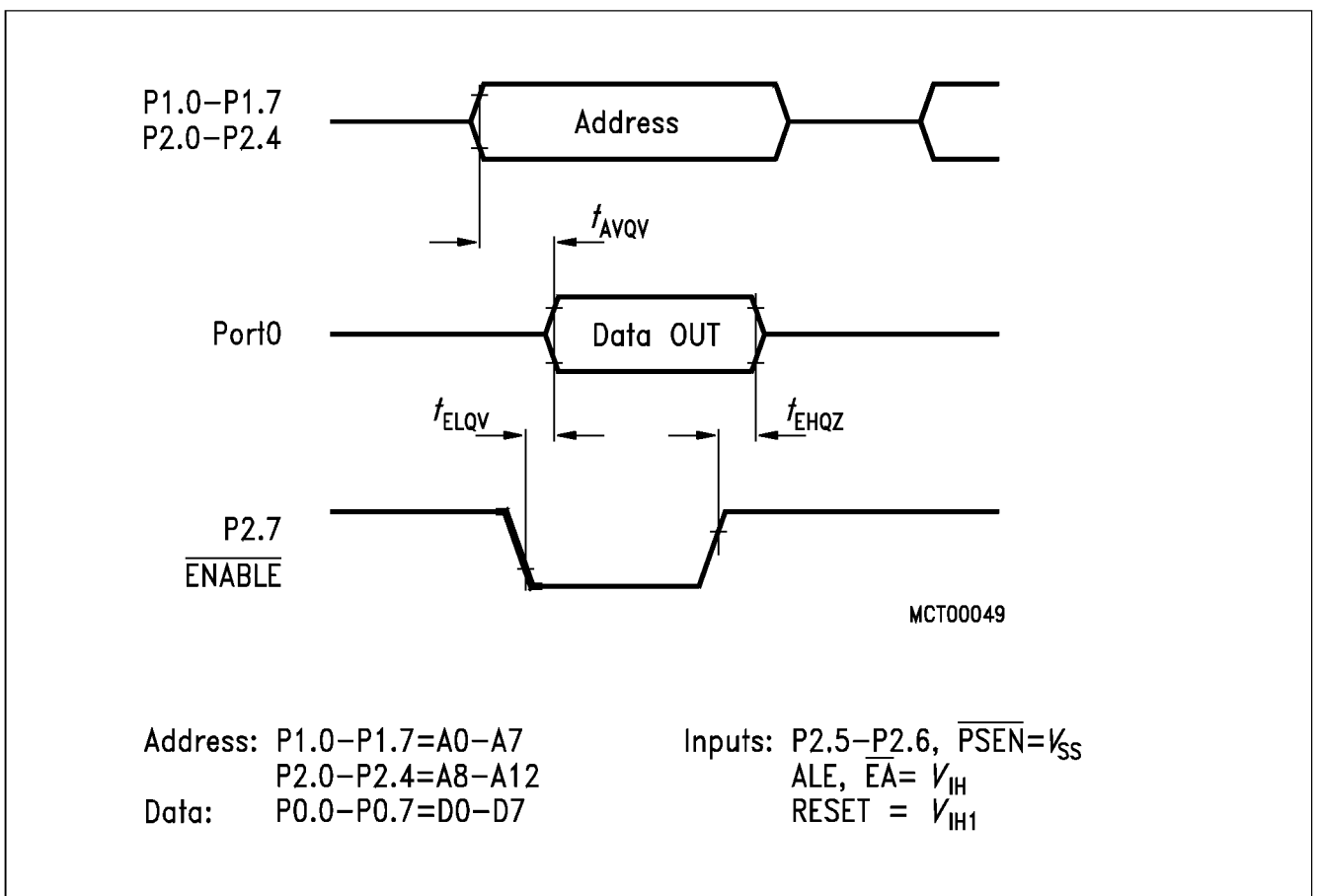

**ROM Verification**

Waveforms

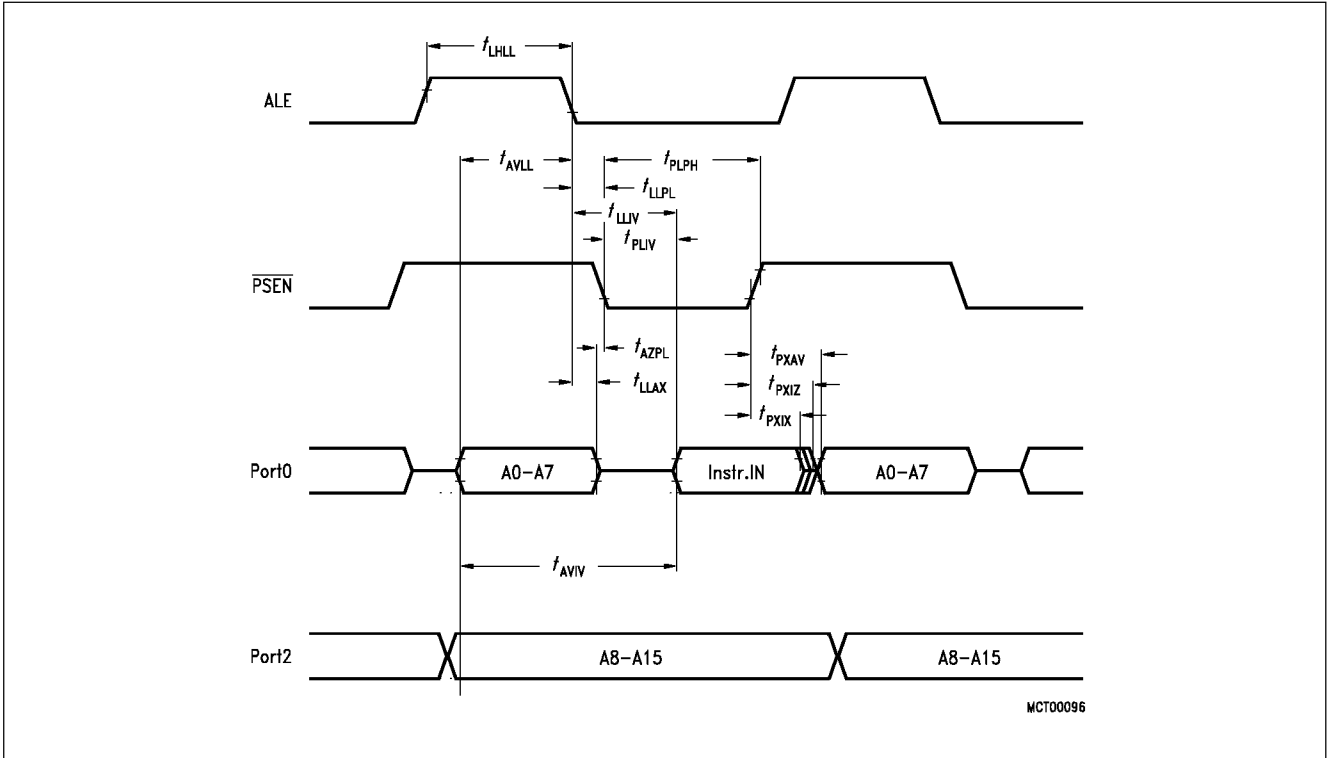

Program Memory Read Cycle

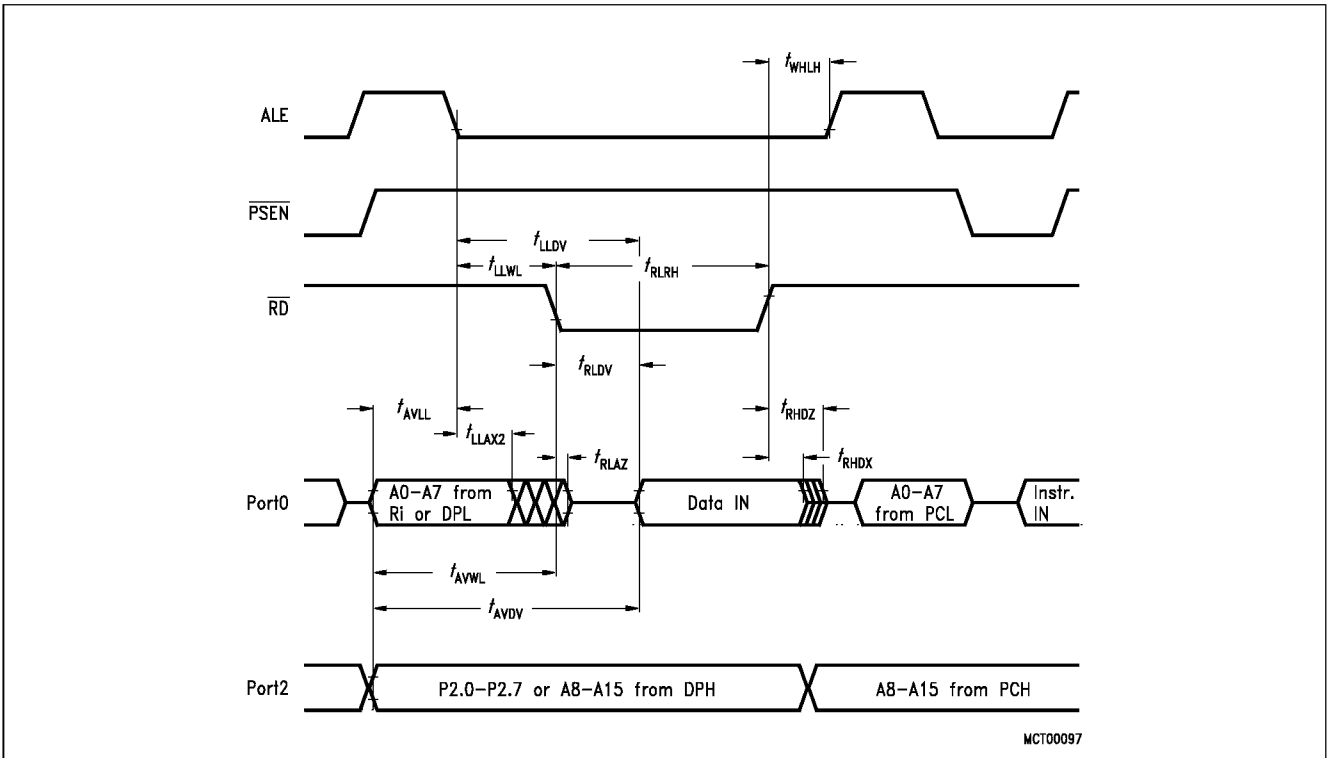

Data Memory Read Cycle

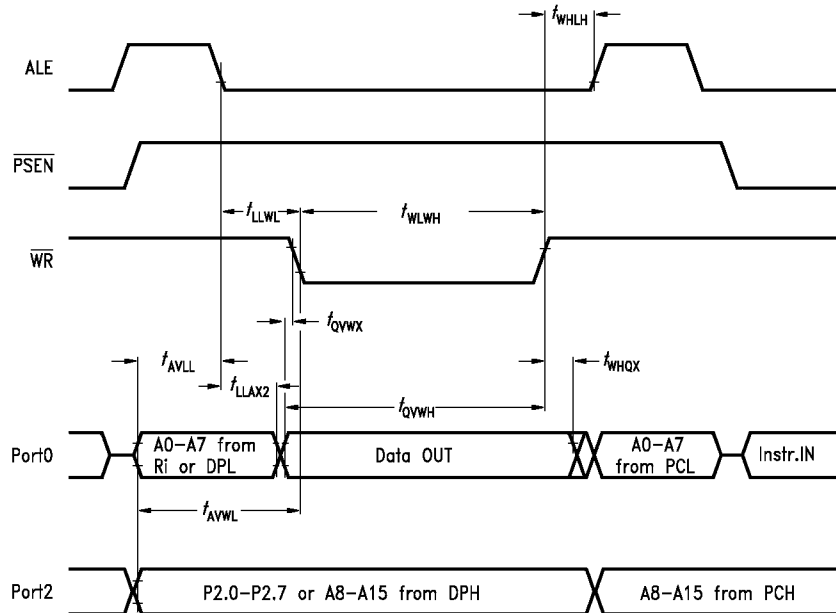

MCT00098

AC inputs during testing are driven at  $V_{CC} - 0.5$  V for a logic '1' and 0.45 V for a logic '0'.  
 Timing measurements are made at  $V_{IH \min}$  for a logic '1' and  $V_{IL \max}$  for a logic '0'.

**Data Memory Write Cycle**

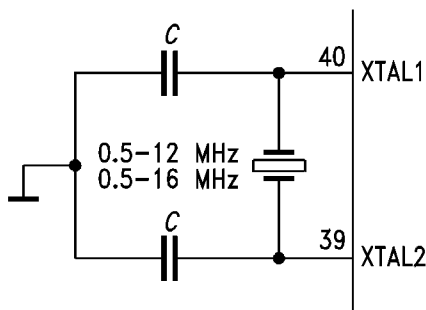

$C = 30\text{pF} \pm 10\text{pF}$   
 (incl. stray capacitance)

**Crystal Oscillator Mode**

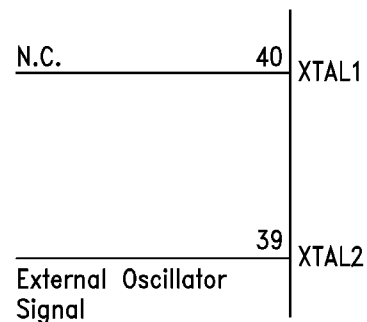

MCS00099

**Driving from External Source**

For timing purposes a port pin is no longer floating when a 100 mV change from load voltage occurs and begins to float when a 100 mV deviation from the load voltage  $V_{OH}/V_{OL}$  occurs.  $I_{OL}/I_{OH} \geq \pm 20$  mA.

**Recommended Oscillator Circuits**

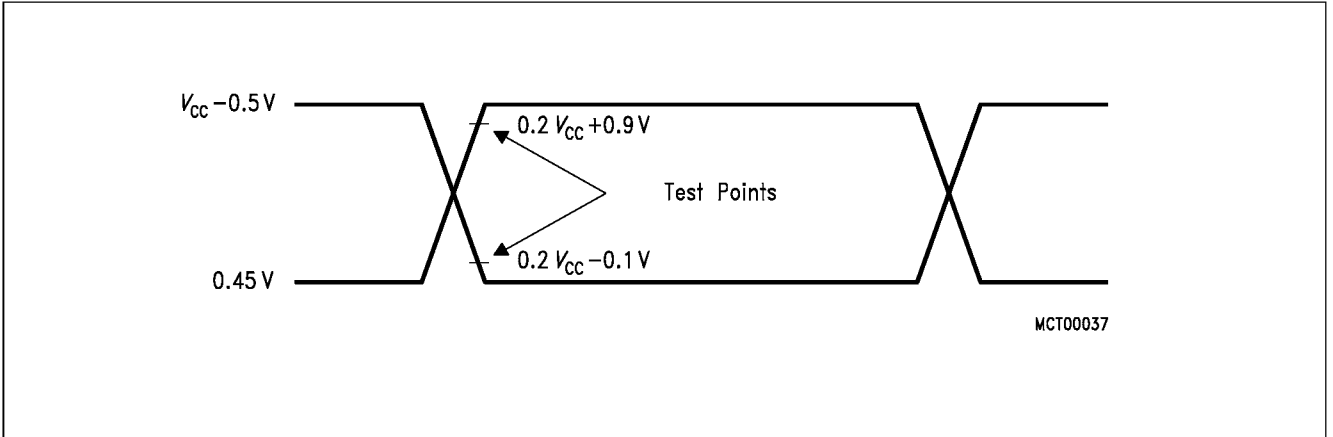

AC Testing: Input, Output Waveforms

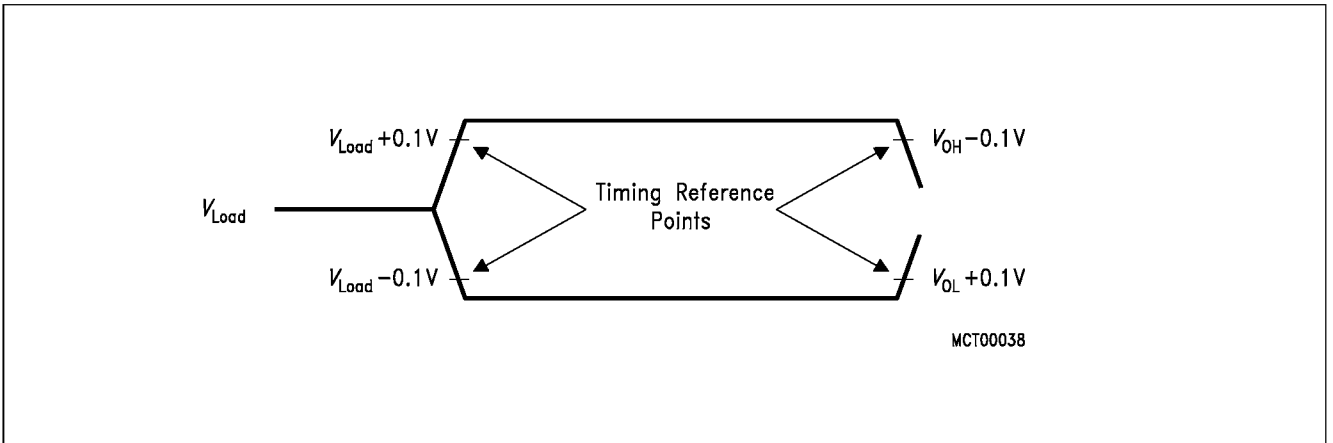

AC Testing: Float Waveforms