

512K-BIT [64Kx8] CMOS EPROM

FEATURES

- 64K x 8 organization
- Single +5V power supply
- +12.5V programming voltage
- Fast access time: 45/55/70/90/100/120/150ns
- Totally static operation

- Completely TTL compatible
- Operating current: 30mA
- Standby current: 100uA
- Package type:
 - 28 pin ceramic DIP, plastic DIP, plastic SOP
 - 32 pin PLCC
 - 28 pin 8 x 13.4 mm TSOP(I)

GENERAL DESCRIPTION

The MX27C512 is a 5V only, 512K-bit, ultraviolet Erasable Programmable Read Only Memory. It is organized as 64K words by 8 bits per word, operates from a single +5volt supply, has a static standby mode, and features fast single address location programming. All programming signals are TTL levels, requiring a single pulse. For programming outside from the system, existing EPROM

programmers may be used. The MX27C512 supports intelligent fast programming algorithm which can result in programming time of less than fifteen seconds.

This EPROM is packaged in industry standard 28 pin dual-in-line packages 32 lead PLCC, 28 lead SOP, and 28 lead TSOP(I) packages.

PIN CONFIGURATIONS

CDIP/PDIP/SOP

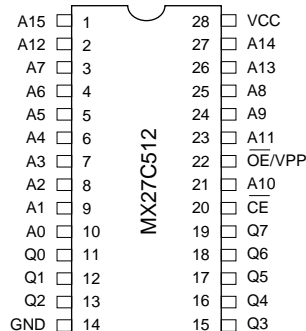

PLCC

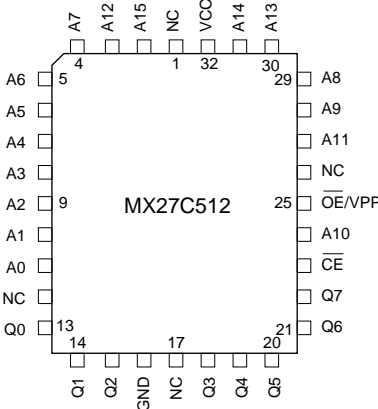

8 x 13.4mm 28TSOP(I)

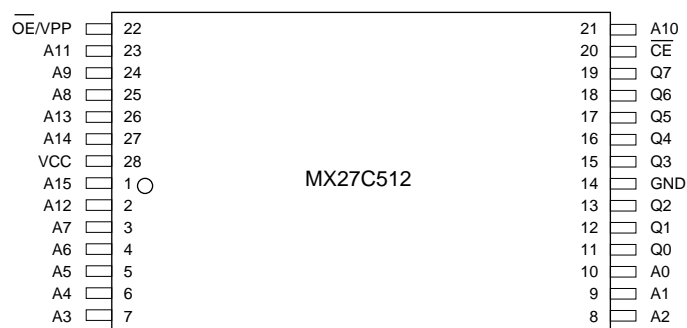

BLOCK DIAGRAM

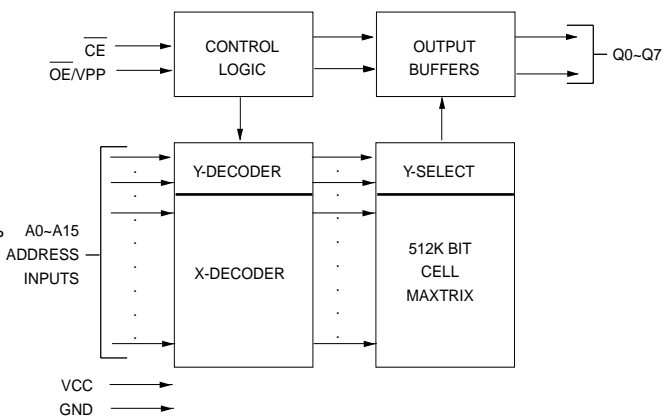

PIN DESCRIPTION

SYMBOL	PIN NAME
A0-A15	Address Input
Q0-Q7	Data Input/Output
CE	Chip Enable Input
OE/VPP	Output Enable Input/Program Supply Voltage
NC	No Internal Connection
VCC	Power Supply Pin (+5V)
GND	Ground Pin

FUNCTIONAL DESCRIPTION

THE ERASURE OF THE MX27C512

The MX27C512 is erased by exposing the chip to an ultraviolet light source. A dosage of 15 W seconds/cm² is required to completely erase a MX27C512. This dosage can be obtained by exposure to an ultraviolet lamp - wavelength of 2537 Angstroms (Å) - with intensity of 12,000 uW/cm² for 15 to 20 minutes. The MX27C512 should be directly under and about one inch from the source and all filters should be removed from the UV light source prior to erasure.

It is important to note that the MX27C512, and similar devices, will be cleared for all bits of their programmed states with light sources having wavelengths shorter than 4000 Å. Although erasure times will be much longer than that with UV sources at 2537 Å, nevertheless the exposure to fluorescent light and sunlight will eventually erase the MX27C512 and exposure to them should be prevented to realize maximum system reliability. If used in such an environment, the package window should be covered by an opaque label or substance.

THE PROGRAMMING OF THE MX27C512

When the MX27C512 is delivered, or it is erased, the chip has all 512K bits in the "ONE" or HIGH state. "ZEROS" are loaded into the MX27C512 through the procedure of programming.

For programming, the data to be programmed is applied with 8 bits in parallel to the data pins.

V_{cc} must be applied simultaneously or before V_{pp}, and removed simultaneously or after V_{pp}. When programming an MXIC EPROM, a 0.1uF capacitor is required across V_{pp} and ground to suppress spurious voltage transients which may damage the device.

FAST PROGRAMMING

The device is set up in the fast programming mode when the programming voltage $\overline{OE}/V_{PP} = 12.75V$ is applied, with V_{CC} = 6.25 V, (Algorithm is shown in Figure 1). The programming is achieved by applying a single TTL low level 100us pulse to the \overline{CE} input after addresses and data line are stable. If the data is not verified, an additional pulse is applied for a maximum of 25 pulses. This process is repeated while sequencing through each address of the device. When the programming mode is completed, the data in all address is verified at V_{CC} = 5V ± 10%.

PROGRAM INHIBIT MODE

Programming of multiple MX27C512s in parallel with different data is also easily accomplished by using the Program Inhibit Mode. Except for \overline{CE} and OE, all like inputs of the parallel MX27C512 may be common. A TTL low-level program pulse applied to an MX27C512 \overline{CE} input with $\overline{OE}/V_{PP} = 12.5 \pm 0.5V$ will program that MX27C512. A high-level \overline{CE} input inhibits the other MX27C512s from being programmed.

PROGRAM VERIFY MODE

Verification should be performed on the programmed bits to determine that they were correctly programmed. The verification should be performed with \overline{OE}/V_{PP} and \overline{CE} , at \overline{VIL} . Data should be verified t_{DV} after the falling edge of \overline{CE} .

AUTO IDENTIFY MODE

The auto identify mode allows the reading out of a binary code from an EPROM that will identify its manufacturer and device type. This mode is intended for use by programming equipment for the purpose of automatically matching the device to be programmed with its corresponding programming algorithm. This mode is functional in the 25°C ± 5°C ambient temperature range that is required when programming the MX27C512.

To activate this mode, the programming equipment must force 12.0 ± 0.5(V_H) on address line A₉ of the device. Two identifier bytes may then be sequenced from the device outputs by toggling address line A₀ from V_{IL} to V_{IH}. All other address lines must be held at V_{IL} during auto identify mode.

Byte 0 (A₀ = V_{IL}) represents the manufacturer code, and byte 1 (A₀ = V_{IH}), the device identifier code. For the MX27C512, these two identifier bytes are given in the Mode Select Table. All identifiers for manufacturer and device codes will possess odd parity, with the MSB (Q₇) defined as the parity bit.

READ MODE

The MX27C512 has two control functions, both of which must be logically satisfied in order to obtain data at the outputs. Chip Enable (\overline{CE}) is the power control and should be used for device selection. Output Enable (\overline{OE}) is the output control and should be used to gate data to the output pins, independent of device selection. Assuming

that addresses are stable, address access time (t_{ACC}) is equal to the delay from \overline{CE} to output (t_{CE}). Data is available at the outputs t_{OE} after the falling edge of \overline{OE} , assuming that \overline{CE} has been LOW and addresses have been stable for at least $t_{ACC} - t_{OE}$.

STANDBY MODE

The MX27C512 has a CMOS standby mode which reduces the maximum V_{CC} current to 100uA. It is placed in CMOS standby when \overline{CE} is at $V_{CC} \pm 0.3$ V. The MX27C512 also has a TTL-standby mode which reduces the maximum V_{CC} current to 1.5 mA. It is placed in TTL-standby when \overline{CE} is at V_{IH} . When in standby mode, the outputs are in a high-impedance state, independent of the \overline{OE} input.

TWO-LINE OUTPUT CONTROL FUNCTION

To accommodate multiple memory connections, a two-line control function is provided to allow for:

1. Low memory power dissipation,
2. Assurance that output bus contention will not occur.

It is recommended that \overline{CE} be decoded and used as the primary device-selecting function, while \overline{OE} be made a common connection to all devices in the array and connected to the READ line from the system control bus. This assures that all deselected memory devices are in their low-power standby mode and that the output pins are only active when data is desired from a particular memory device.

SYSTEM CONSIDERATIONS

During the switch between active and standby conditions, transient current peaks are produced on the rising and falling edges of Chip Enable. The magnitude of these transient current peaks is dependent on the output capacitance loading of the device. At a minimum, a 0.1 uF ceramic capacitor (high frequency, low inherent inductance) should be used on each device between V_{CC} and GND to minimize transient effects. In addition, to overcome the voltage drop caused by the inductive effects of the printed circuit board traces on EPROM arrays, a 4.7 uF bulk electrolytic capacitor should be used between V_{CC} and GND for each eight devices. The location of the capacitor should be close to where the power supply is connected to the array.

MODE SELECT TABLE

MODE	PINS				
	\overline{CE}	$\overline{OE/VPP}$	A0	A9	OUTPUTS
Read	VIL	VIL	X	X	DOUT
Output Disable	VIL	VIH	X	X	High Z
Standby (TTL)	VIH	X	X	X	High Z
Standby (CMOS)	$V_{CC} \pm 0.3V$	X	X	X	High Z
Program	VIL	VPP	X	X	DIN
Program Verify	VIL	VIL	X	X	DOUT
Program Inhibit	VIH	VPP	X	X	High Z
Manufacturer Code(3)	VIL	VIL	VIL	VH	C2H
Device Code(3)	VIL	VIL	VIH	VH	91H

- NOTES:**
1. $V_H = 12.0$ V \pm 0.5 V
 2. X = Either V_{IH} or VIL

3. A1 - A8 = A10 - A15 = VIL (For auto select)
4. See DC Programming Characteristics for VPP voltage during programming.

Figure1. FAST PROGRAMMING FLOW CHART

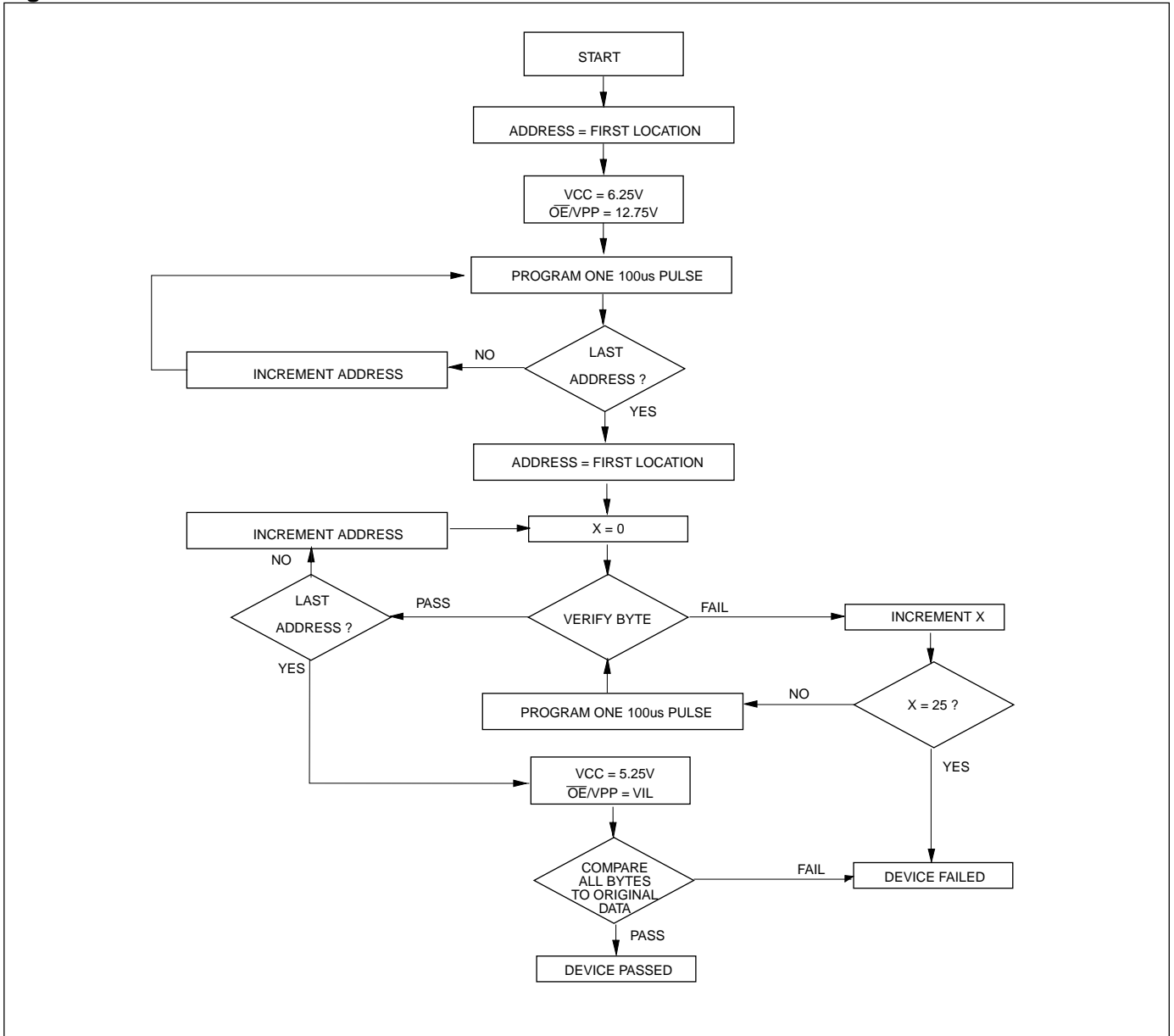

SWITCHING TEST CIRCUITS

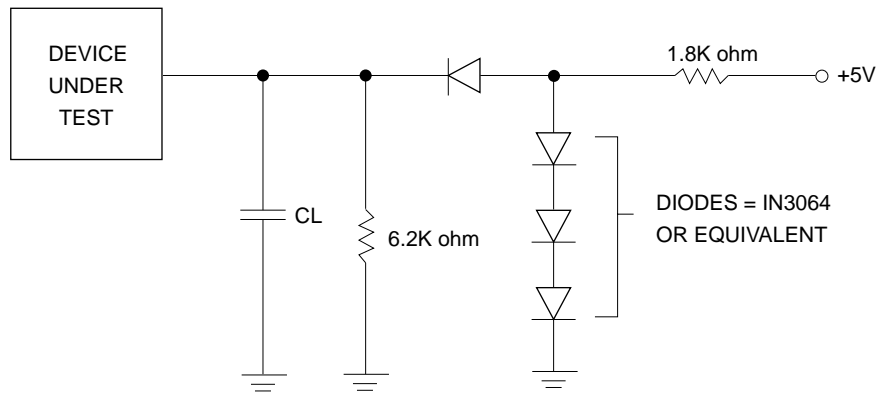

CL = 100 pF including jig capacitance (30pF for 45/55/70 ns parts)

SWITCHING TEST WAVEFORMS

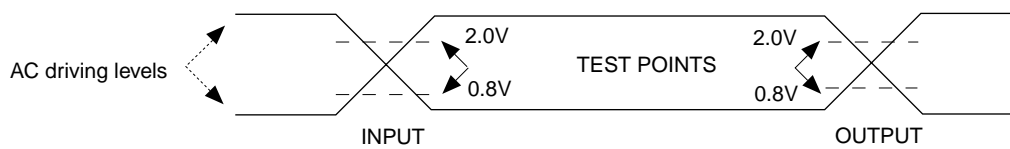

AC TESTING: AC driving levels are 2.4V/0.4V for commercial grade, 3.0V/0V for industrial grade.
Input pulse rise and fall times are ≤ 10 ns.

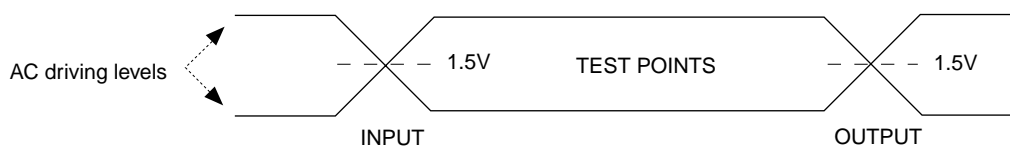

AC TESTING: (1) AC driving levels are 3.0V/0V for both commercial grade and industrial grade.
Input pulse rise and fall times are ≤ 10 ns.
(2) For MX27C1000-45, MX27C1000/1001-55, MX27C1000/1001-70.

ABSOLUTE MAXIMUM RATINGS

RATING	VALUE
Ambient Operating Temperature	-40°C to 85°C
Storage Temperature	-65°C to 125°C
Applied Input Voltage	-0.5V to 7.0V
Applied Output Voltage	-0.5V to VCC + 0.5V
VCC to Ground Potential	-0.5V to 7.0V
A9 & Vpp	-0.5V to 13.5V

NOTICE:

Stresses greater than those listed under ABSOLUTE MAXIMUM RATINGS may cause permanent damage to the device. This is a stress rating only and functional operation of the device at these or any other conditions above those indicated in the operational sections of this specification is not implied. Exposure to absolute maximum rating conditions for extended period may affect reliability.

NOTICE:

Specifications contained within the following tables are subject to change.

DC/AC Operating Conditions for Read Operation

		MX27C512						
		-45	-55	-70	-90	-10	-12	-15
Operating Temperature	Commercial	0°C to 55°C	0°C to 70°C	0°C to 70°C	0°C to 70°C	0°C to 70°C	0°C to 70°C	0°C to 70°C
	Industrial	-40°C to 85°C	-40°C to 85°C	-40°C to 85°C	-40°C to 85°C	-40°C to 85°C	-40°C to 85°C	-40°C to 85°C
Vcc Power Supply		5V ± 5%	5V ± 10%	5V ± 10%	5V ± 10%	5V ± 10%	5V ± 10%	5V ± 10%

DC CHARACTERISTICS

SYMBOL	PARAMETER	MIN.	MAX.	UNIT	CONDITIONS
VOH	Output High Voltage	2.4		V	IOH = -0.4mA
VOL	Output Low Voltage		0.4	V	IOL = 2.1mA
VIH	Input High Voltage	2.0	VCC + 0.5	V	
VIL	Input Low Voltage	-0.2	0.8	V	
ILI	Input Leakage Current	-10	10	uA	VIN = 0 to 5.5V
ILO	Output Leakage Current	-10	10	uA	VOUT = 0 to 5.5V
ICC3	VCC Power-Down Current		100	uA	$\overline{CE} = VCC \pm 0.3V$
ICC2	VCC Standby Current		1.5	mA	$\overline{CE} = VIH$
ICC1	VCC Active Current		30	mA	$\overline{CE} = VIL, f=5MHz, Iout = 0mA$
IPP	VPP Supply Current Read		10	uA	$\overline{CE} = VIL, VPP = 5.5V$

CAPACITANCE TA = 25°C, f = 1.0 MHz (Sampled only)

SYMBOL	PARAMETER	MIN.	MAX.	UNIT	CONDITIONS
CIN	Input Capacitance	8	12	pF	VIN = 0V
COUT	Output Capacitance	8	12	pF	VOUT = 0V
Vpp	VPP Capacitance	18	25	pF	VPP = 0V

AC CHARACTERISTICS

SYMBOL	PARAMETER	27C512-45		27C512-55		27C512-70		27C512-90		UNIT	CONDITIONS
		MIN.	MAX.	MIN.	MAX.	MIN.	MAX.	MIN.	MAX.		
tACC	Address to Output Delay		45		55		70		90	ns	$\overline{CE} = \overline{OE} = \text{VIL}$
tCE	Chip Enable to Output Delay		45		55		70		90	ns	$\overline{OE} = \text{VIL}$
tOE	Output Enable to Output Delay		25		30		35		40	ns	$\overline{CE} = \text{VIL}$
tDF	\overline{OE} High to Output Float, or \overline{CE} High to Output Float	0	17	0	20	0	20	0	25	ns	
tOH	Output Hold from Address, \overline{CE} or \overline{OE} which ever occurred first	0		0		0		0		ns	

SYMBOL	PARAMETER	27C512-10		27C512-12		27C512-15		UNIT	CONDITIONS
		MIN.	MAX.	MIN.	MAX.	MIN.	MAX.		
tACC	Address to Output Delay		100		120		150	ns	$\overline{CE} = \overline{OE} = \text{VIL}$
tCE	Chip Enable to Output Delay		100		120		150	ns	$\overline{OE} = \text{VIL}$
tOE	Output Enable to Output Delay		45		50		65	ns	$\overline{CE} = \text{VIL}$
tDF	\overline{OE} High to Output Float, or \overline{CE} High to Output Float	0	30	0	35	0	50	ns	
tOH	Output Hold from Address, \overline{CE} or \overline{OE} which ever occurred first	0		0		0		ns	

DC PROGRAMMING CHARACTERISTICS TA = 25°C ± 5°C

SYMBOL	PARAMETER	MIN.	MAX.	UNIT	CONDITIONS
VOH	Output High Voltage	2.4		V	IOH = -0.40mA
VOL	Output Low Voltage		0.4	V	IOL = 2.1mA
VIH	Input High Voltage	2.0	VCC + 0.5	V	
VIL	Input Low Voltage	-0.2	0.8	V	
ILI	Input Leakage Current	-10	10	uA	VIN = 0 to 5.5V
VH	A9 Auto Select Voltage	11.5	12.5	V	
ICC3	VCC Supply Current(Program & Verify)		40	mA	
IPP2	VPP Supply Current(Program)		30	mA	$\overline{CE} = \text{VIL}$
VCC1	Fast Programming Supply Voltage	6.00	6.50	V	
VPP1	Fast Programming Voltage	12.5	13.0	V	

AC PROGRAMMING CHARACTERISTICS $T_A = 25^\circ\text{C} \pm 5^\circ\text{C}$

SYMBOL	PARAMETER	MIN.	MAX.	UNIT	CONDITIONS
tAS	Address Setup Time	2		us	
tDS	Data Setup Time	2		us	
tAH	Address Hold Time	0		us	
tDH	Data Hold Time	2		us	
tDFP	Chip Enable to Output Float Delay	0	130	ns	
tVPS	VPP Setup Time	2		us	
tPW	$\overline{\text{CE}}$ Program Pulse Width	95	105	us	
tVCS	Vcc Setup Time	2		us	
tDV	Data Valid from $\overline{\text{CE}}$		150	ns	
tOEH	$\overline{\text{OE}}$ /VPP Hold Time	2		ns	
tVR	$\overline{\text{OE}}$ /VPP Recovery Time	2		ns	

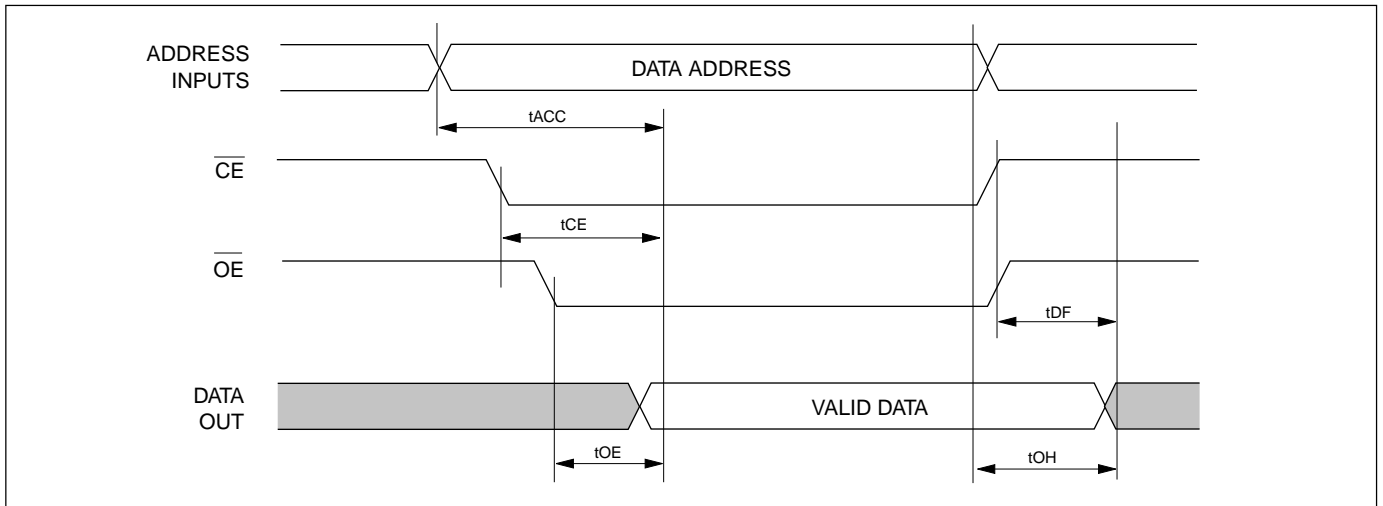
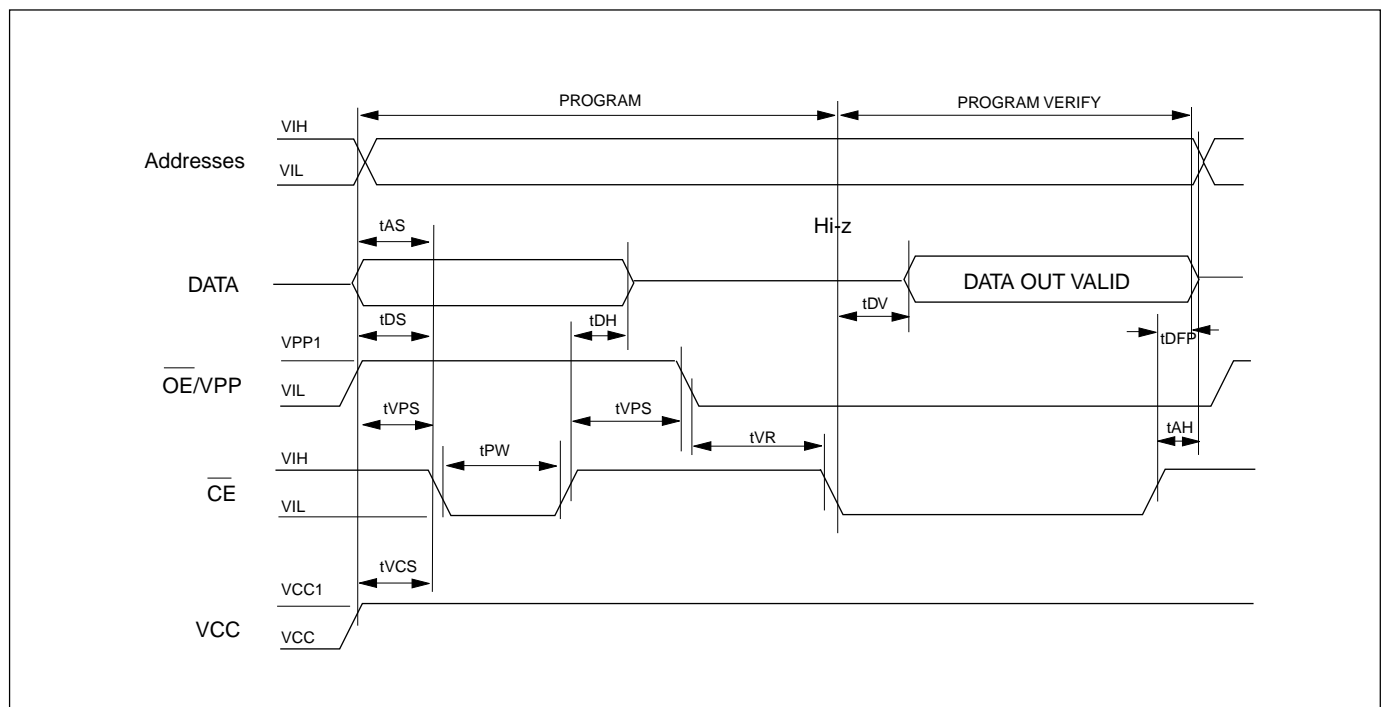
WAVEFORMS
READ CYCLE

FAST PROGRAMMING ALGORITHM WAVEFORM

**ORDERING INFORMATION
CERAMIC PACKAGE**

PART NO.	ACCESS TIME(ns)	OPERATING	STANDBY	OPERATING	PACKAGE
		CURRENT MAX.(mA)	CURRENT MAX.(uA)	TEMPERATURE	
MX27C512DC-45	45	30	100	0°C to 70°C	28 Pin DIP
MX27C512DC-55	55	30	100	0°C to 70°C	28 Pin DIP
MX27C512DI-45	45	30	100	-40°C to 85°C	28 Pin DIP
MX27C512DI-55	55	30	100	-40°C to 85°C	28 Pin DIP

PLASTIC PACKAGE

PART NO.	ACCESS TIME(ns)	OPERATING	STANDBY	OPERATING	PACKAGE
		CURRENT MAX.(mA)	CURRENT MAX.(uA)	TEMPERATURE	
MX27C512MC-45	45	30	100	0°C to 70°C	28 Pin SOP
MX27C512PC-45	45	30	100	0°C to 70°C	28 Pin DIP
MX27C512QC-45	45	30	100	0°C to 70°C	32 Pin PLCC
MX27C512TC-45	45	30	100	0°C to 70°C	28 PinTSOP(I)
MX27C512MC-55	55	30	100	0°C to 70°C	28 Pin SOP
MX27C512PC-55	55	30	100	0°C to 70°C	28 Pin DIP
MX27C512QC-55	55	30	100	0°C to 70°C	32 Pin PLCC
MX27C512TC-55	55	30	100	0°C to 70°C	28 Pin TSOP(I)
MX27C512MC-70	70	30	100	0°C to 70°C	28 Pin SOP
MX27C512PC-70	70	30	100	0°C to 70°C	28 Pin DIP
MX27C512QC-70	70	30	100	0°C to 70°C	32 Pin PLCC
MX27C512TC-70	70	30	100	0°C to 70°C	28 Pin TSOP(I)
MX27C512MC-90	90	30	100	0°C to 70°C	28 Pin SOP
MX27C512PC-90	90	30	100	0°C to 70°C	28 Pin DIP
MX27C512QC-90	90	30	100	0°C to 70°C	32 Pin PLCC
MX27C512TC-90	90	30	100	0°C to 70°C	28 Pin TSOP(I)
MX27C512MC-12	120	30	100	0°C to 70°C	28 Pin SOP
MX27C512PC-12	120	30	100	0°C to 70°C	28 Pin DIP
MX27C512QC-12	120	30	100	0°C to 70°C	32 Pin PLCC
MX27C512TC-12	120	30	100	0°C to 70°C	28 Pin TSOP(I)
MX27C512MC-15	150	30	100	0°C to 70°C	28 Pin SOP
MX27C512PC-15	150	30	100	0°C to 70°C	28 Pin DIP
MX27C512QC-15	150	30	100	0°C to 70°C	32 Pin PLCC
MX27C512TC-15	150	30	100	0°C to 70°C	28 Pin TSOP(I)
MX27C512MI-45	45	30	100	-40°C to 85°C	28 Pin SOP
MX27C512PI-45	45	30	100	-40°C to 85°C	28 Pin DIP
MX27C512QI-45	45	30	100	-40°C to 85°C	32 Pin PLCC
MX27C512TI-45	45	30	100	-40°C to 85°C	28 PinTSOP(I)



MX27C512

MX27C512MI-55	55	30	100	-40°C to 85°C	28 Pin SOP
MX27C512PI-55	55	30	100	-40°C to 85°C	28 Pin DIP
MX27C512QI-55	55	30	100	-40°C to 85°C	32 Pin PLCC
MX27C512TI-55	55	30	100	-40°C to 85°C	28 Pin TSOP(I)
MX27C512MI-70	70	30	100	-40°C to 85°C	28 Pin SOP
MX27C512PI-70	70	30	100	-40°C to 85°C	28 Pin DIP
MX27C512QI-70	70	30	100	-40°C to 85°C	32 Pin PLCC
MX27C512TI-70	70	30	100	-40°C to 85°C	28 Pin TSOP(I)
MX27C512MI-90	90	30	100	-40°C to 85°C	28 Pin SOP
MX27C512PI-90	90	30	100	-40°C to 85°C	28 Pin DIP
MX27C512QI-90	90	30	100	-40°C to 85°C	32 Pin PLCC
MX27C512TI-90	90	30	100	-40°C to 85°C	28 Pin TSOP(I)
MX27C512MI-12	120	30	100	-40°C to 85°C	28 Pin SOP
MX27C512PI-12	120	30	100	-40°C to 85°C	28 Pin DIP
MX27C512QI-12	120	30	100	-40°C to 85°C	32 Pin PLCC
MX27C512TI-12	120	30	100	-40°C to 85°C	28 Pin TSOP(I)
MX27C512MI-15	150	30	100	-40°C to 85°C	28 Pin SOP
MX27C512PI-15	150	30	100	-40°C to 85°C	28 Pin DIP
MX27C512QI-15	150	30	100	-40°C to 85°C	32 Pin PLCC
MX27C512TI-15	150	30	100	-40°C to 85°C	28 Pin TSOP(I)

PACKAGE INFORMATION
28-PIN CERDIP(MSI) WITH WINDOW (600 mil)

ITEM	MILLIMETERS	INCHES
A	37.69 max	1.485 max
B	1.85 ± .30	.073 ± .012
C	2.54 [TP]	.100 [TP]
D	.46 ± .05	.018 ± .002
E	33.02	1.300
F	1.40 ± .05	.055 ± .002
G	3.43 ± .38	.135 ± .015
H	.96 ± .43	.038 ± .017
I	4.87	.198
J	15.48 ± .13	.610 ± .005
K	13.38 ± .38	.527 ± .015
L	.25 ± .13	.010 ± .005
M	0 ~ 15°	0 ~ 15°
N	∅7.11	∅.280

NOTE: Each lead centerline is located within .25 mm [.01 inch] of its true position [TP] at maximum material condition.

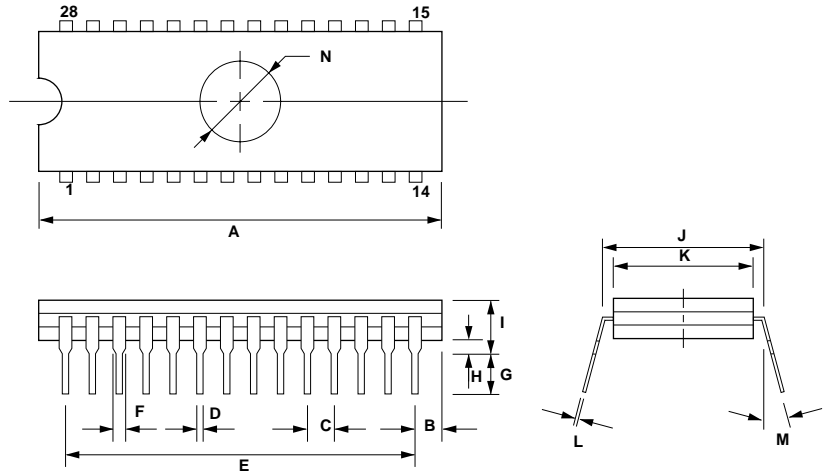
28-PIN PLASTIC DIP (600 mil)

ITEM	MILLIMETERS	INCHES
A	37.34 max	1.470 max
B	2.03 [REF]	.080 [REF]
C	2.54 [TP]	.100 [TP]
D	.46 [Typ.]	.018 [Typ.]
E	32.99	1.300
F	1.52 [Typ.]	.060 [Typ.]
G	3.30 ± .25	.130 ± .010
H	.51 [REF]	.020 [REF]
I	3.94 ± .25	.155 ± .010
J	5.33 max.	.210 max.
K	15.22 ± .25	.600 ± .010
L	13.84 ± .25	.545 ± .010
M	.25 [Typ.]	.010 [Typ.]

NOTE: Each lead centerline is located within .25 mm [.01 inch] of its true position [TP] at maximum material condition.

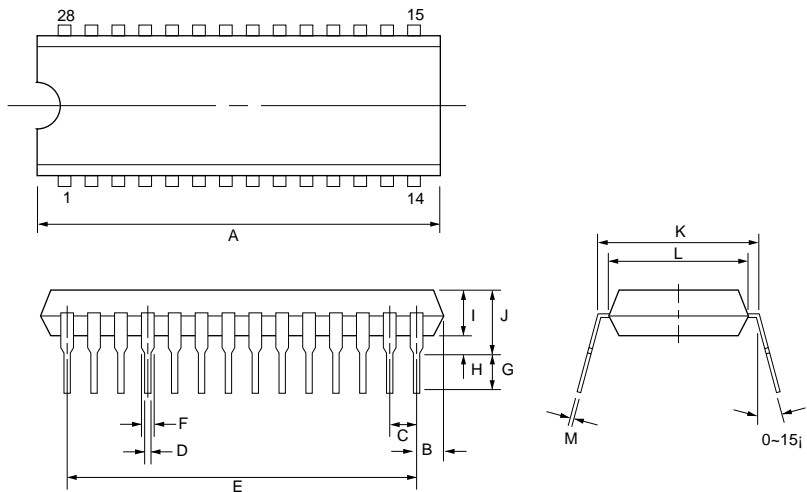

PACKAGE INFORMATION
32-PIN PLASTIC LEADED CHIP CARRIER (PLCC)

ITEM	MILLIMETERS	INCHES
A	12.44 ± .13	.490 ± .005
B	11.50 ± .13	.453 ± .005
C	14.04 ± .13	.553 ± .005
D	14.98 ± .13	.590 ± .005
E	1.93	.076
F	3.30 ± .25	.130 ± .010
G	2.03 ± .13	.080 ± .005
H	.51 ± .13	.020 ± .005
I	1.27 [Typ.]	.050 [Typ.]
J	.71 [REF]	.028 [REF]
K	.46 [REF]	.018 [REF]
L	10.40/12.94 (W) (L)	.410/.510 (W) (L)
M	.89 R	.035 R
N	.25 (TYP.)	.010 (TYP.)

NOTE: Each lead centerline is located within .25 mm [.01 inch] of its true position [TP] at maximum material condition.

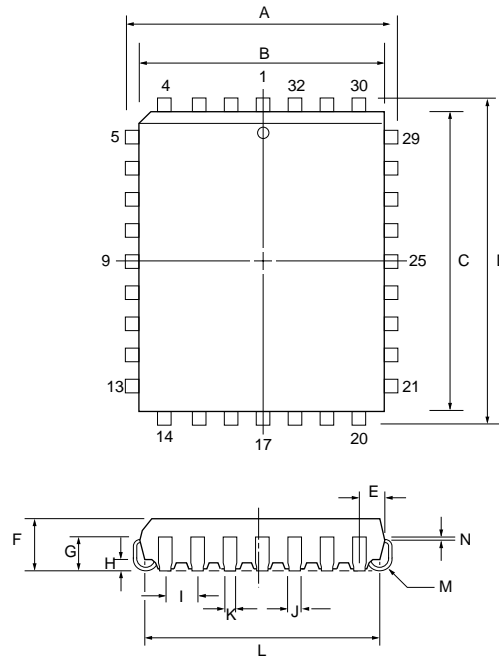
28-PIN PLASTIC SOP(330 mil)

ITEM	MILLIMETERS	INCHES
A	18.11 max.	.713 max.
B	1.194 max	.047 max
C	1.27 [TP]	.050 [TP]
D	.41 [Typ.]	.016 [Typ.]
E	.10 min.	.004 min.
F	2.84 max.	.112 max.
G	2.49 ± .13	.098 ± .005
H	11.81 ± .31	.465 ± .012
I	8.41 ± .13	.331 ± .005
J	1.70 ± .20	.067 ± .008
K	.25 [Typ.]	.010 [Typ.]
L	.762	.03

NOTE: Each lead centerline is located within .25 mm [.01 inch] of its true position [TP] at maximum material condition.

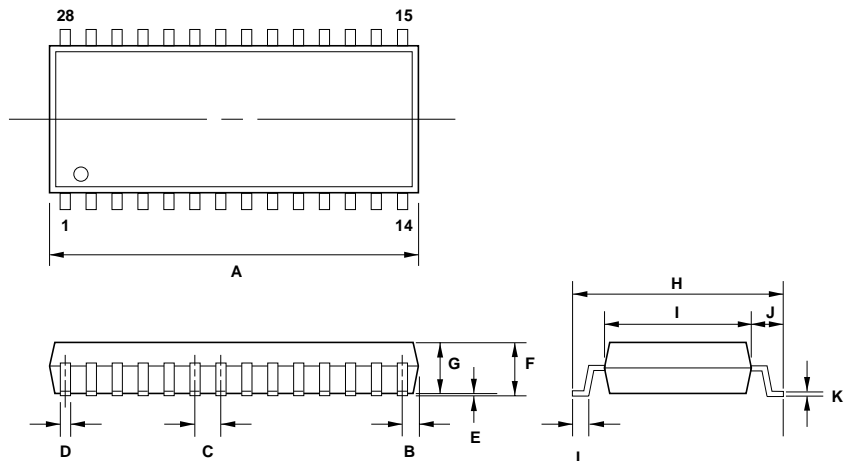

8 x 13.4mm 28-PIN PLASTIC TSOP

ITEM	MILLIMETERS
A	13.4 ± .2
B	11.8 ± .1
C	8.0 ± .1
D	.15 ± .01
F	.2 ± .03
H	.55 [Typ.]
I	.425 [Typ.]
J	.05 [Min.]
K	1.00 ± .05
L	1.25 [Max.]
M	.05 ± .20
N	0° ~ 5°

NOTE: Each lead centerline is located within .25 mm of its true position [TP] at maximum material condition.

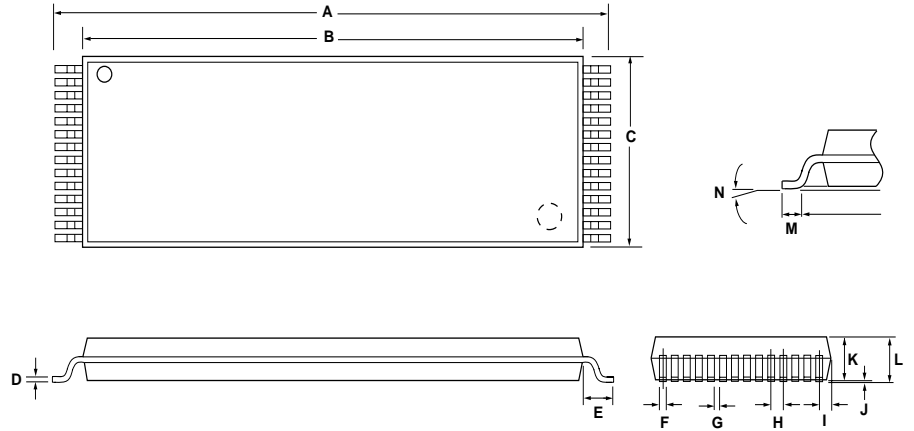

Revision History

Revision #	Description	Date
3.3	Programming Flow Chart corrected, programming verify after whole array programmed with 1 pulse.	
4.0	1) Reduce operating current change from 40mA to 30mA. 2) Add 28-TSOP(I) and 28-SOP packages offering. 3) Eliminate Interactive Programming Mode.	
4.1	IPP 100uA --> 10uA	08/07/1997
4.2	CDIP 70/90/100/120/150ns speed grades deleted from ordering information.	05/07/1998

MACRONIX INTERNATIONAL Co., LTD.**HEADQUARTERS:**

TEL:+886-3-578-8888

FAX:+886-3-578-8887

EUROPE OFFICE:

TEL:+32-2-456-8020

FAX:+32-2-456-8021

JAPAN OFFICE:

TEL:+81-44-246-9100

FAX:+81-44-246-9105

SINGAPORE OFFICE:

TEL:+65-747-2309

FAX:+65-748-4090

TAIPEI OFFICE:

TEL:+886-3-509-3300

FAX:+886-3-509-2200

MACRONIX AMERICA, INC.

TEL:+1-408-453-8088

FAX:+1-408-453-8488

CHICAGO OFFICE:

TEL:+1-847-963-1900

FAX:+1-847-963-1909

[http : //www.macronix.com](http://www.macronix.com)