

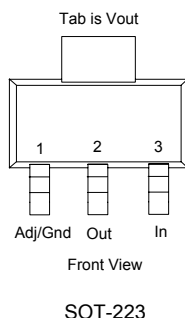

Description

The SE8117 series of high performance low dropout voltage regulators are designed for applications that require efficient conversion and fast transient response.

Pin Configuration



Features

- Low Dropout Performance.
- Guaranteed 1A Output Current.
- Wide Input Supply Voltage Range.
- Over-temperature and Over-current Protection.
- Fixed or Adjustable Output Voltage.
- Rugged 3KV ESD withstand capability.
- Available in SOT-223 Packages.

Application

- Active SCSI Terminators.
- High Efficiency Linear Regulators.
- 5V to 3.3V Linear Regulators
- Motherboard Clock Supplies.

Ordering Information

Device	Package	V _{OUT} Volts
SE8117TA	SOT-223	Output voltage is adjustable.
SE8117TXX	SOT-223	XX denotes voltage options. Available voltages are 1.5V, 1.8V, 2.5V, 3.0V, and 3.3V.

Absolute Maximum Rating

Symbol	Parameter	Maximum	Units
V _{IN}	Input Supply Voltage	9	V
θ _{JC}	Thermal Resistance Junction to Case SOT-223	15	°C/W
θ _{JA}	Thermal Resistance Junction to Ambient SOT-223	156	°C/W
T _J	Operating Junction Temperature Range	0 to 125	°C
T _{STG}	Storage Temperature Range	-40 to 150	°C
T _{LEAD}	Lead Temperature (Soldering 10 Sec)	260	°C



Electrical Characteristic

$V_{IN,MAX} \leq 8V$, $V_{IN,MIN} - V_{OUT} = 1.5V$, $I_{OUT} = 10mA$, $C_{IN} = 10\mu F$, $C_{OUT} = 22\mu F$, $T_J = 0 - 125^\circ C$, unless otherwise specified.

Symbol	Parameter	Test Condition	Min	Typ	Max	Units
V_O	Output Voltage ⁽¹⁾	$10mA \leq I_{OUT} \leq 1A$, $T_A = 25^\circ C$, SE8117T15 SE8117T18 SE8117T25 SE8117T30 SE8117T33	(-2%)	1.5 1.8 2.5 3.0 3.3	(+2%)	V
V_{REF}	Reference Voltage ⁽¹⁾ (Adj. Voltage Version)	$10mA \leq I_{OUT} \leq 1A$	1.225 (-2%)	1.250	1.275 (+2%)	V
V_{SR}	Line Regulation ⁽¹⁾	$I_{OUT} = 10mA$		0.3		%
V_{LR}	Load Regulation ⁽¹⁾	$(V_{IN} - V_{OUT}) = 2V$ $10mA \leq I_{OUT} \leq 1A$		0.4		%
I_Q	Quiescent Current			9		mA
I_{ADJ}	Adjust Pin Current			48		μA
ΔI_{ADJ}	Adjust Pin Current Change	$10mA \leq I_{OUT} \leq 1A$		0.2		μA
V_D	Dropout Voltage ⁽²⁾	$\Delta V_{REF} = 1\%$, $I_{OUT} = 1A$		1.1		V
I_O	Minimum Load Current			4		mA
I_{CL}	Current Limit			1.8		A
T_C	Temperature Coefficient			0.07		%/ $^\circ C$
OTP	Thermal Protection			175		$^\circ C$
V_N	RMS Output Noise	$T_A = 25^\circ C$, $10Hz \leq f \leq 10kHz$		0.003		% V_O
R_A	Ripple Rejection Ratio	$f = 120Hz$, $C_{OUT} = 22\mu F$ (Tantalum), $(V_{IN} - V_{OUT}) = 3V$, $I_{OUT} = 1A$		72		dB

Notes:

1. Low duty cycle pulse testing with which T_J remains unchanged.
2. ΔV_{OUT} , $\Delta V_{REF} = 1\%$.



Typical Applications

Adjustable Voltage Regulator

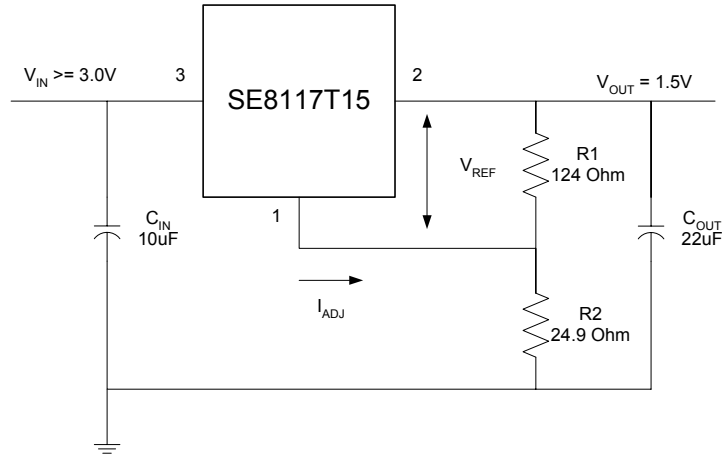

Fixed Voltage Regulator

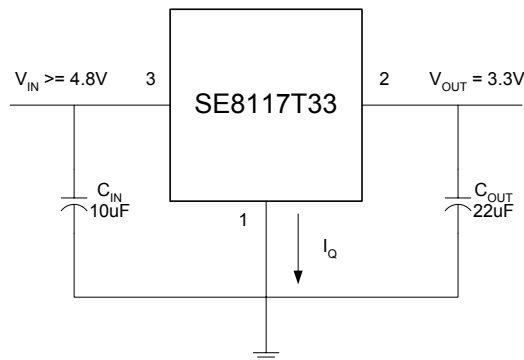



Typical Performance Characteristics

Reference Voltage vs Junction Temperature

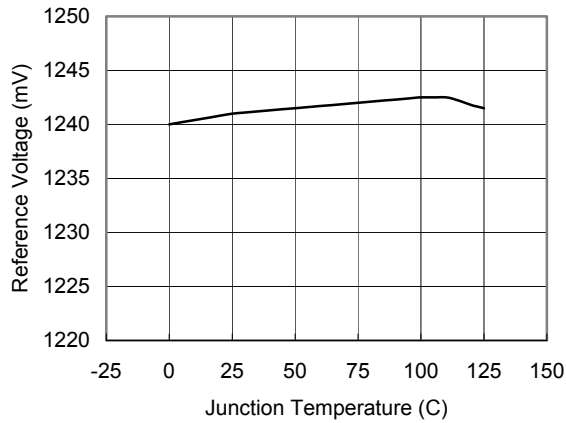

Line Transients

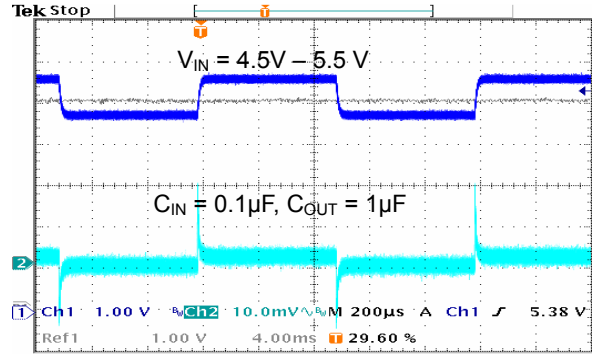

Output Voltage vs Junction Temperature

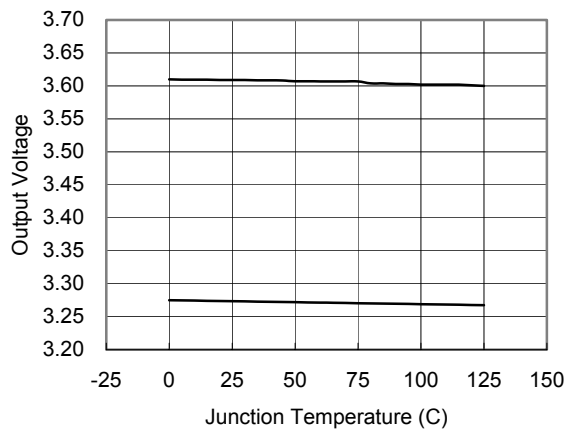

Load Transients

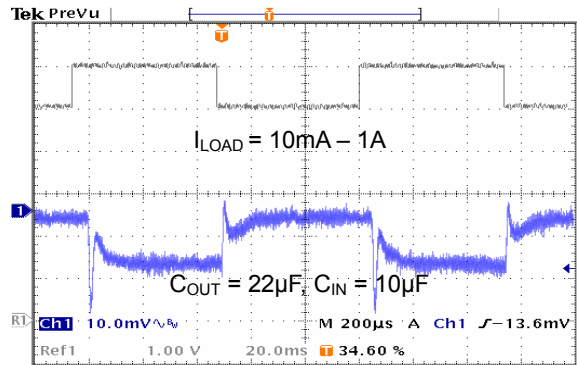

Dropout Voltage vs Output Current

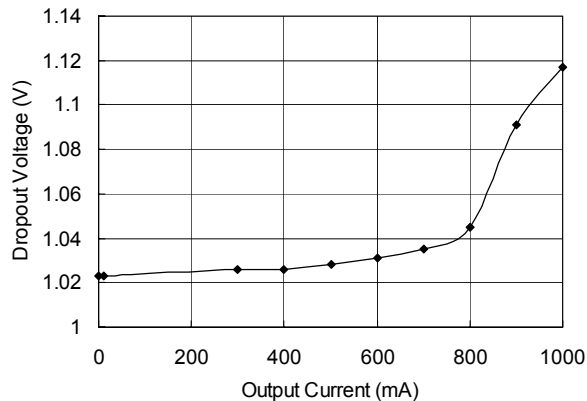



Outline Drawing for SOT-223

