

PQ30VB11

Variable Output Low Power-Loss Voltage Regulator(Built-in Overheat Shut-Down Function)

■ Features

- Compact resin full-mold package
- Low power-loss (Dropout voltage : MAX. 0.5V)
- Overheat shut-down function (keep shut-down output until power-on again)
- Variable output voltage (Setting range : 1.5 to 30V)
- Overcurrent protection type
- High-precision output type (Reference voltage precision : $\pm 2.0\%$)

■ Applications

- Series power supply for TVs and VCRs
- Switching power supply

■ Outline Dimensions

(Unit : mm)

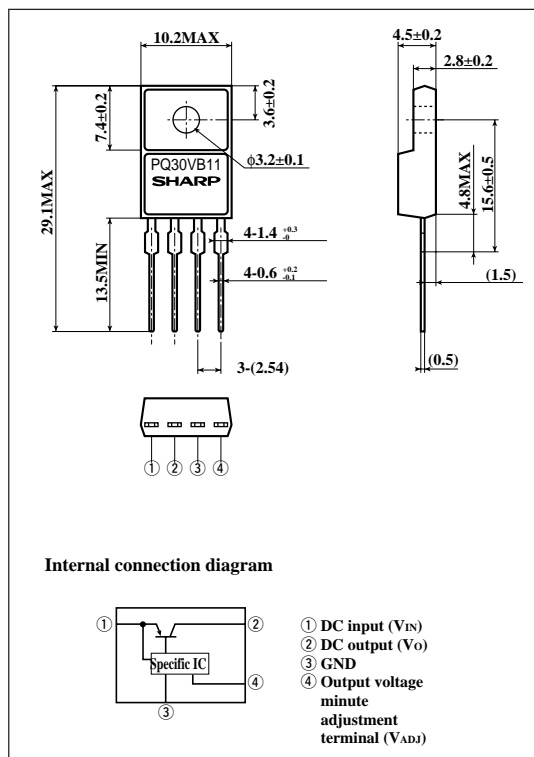

■ Absolute Maximum Ratings

(T_a=25°C)

Parameter	Symbol	Rating	Unit
*1 Input voltage	V _{IN}	35	V
*1 Output adjustment terminal voltage	V _{ADJ}	7	V
Output current	I _O	1	A
Power dissipation (No heat sink)	P _{D1}	1.25	W
Power dissipation (With infinite heat sink)	P _{D2}	12.5	W
*2 Junction temperature	T _j	150	°C
Operating temperature	T _{opr}	-20 to +80	°C
Storage temperature	T _{atg}	-40 to +150	°C
*3 Soldering temperature	T _{sol}	260	°C

*1 All are open except GND and applicable terminals.

*2 Overheat shut-down function operates at T_j>=110°C.

*3 For 10s

· Please refer to the chapter "Handling Precautions".

SHARP

"In the absence of confirmation by device specification sheets, SHARP takes no responsibility for any defects that may occur in equipment using any SHARP devices shown in catalogs, data books, etc. Contact SHARP in order to obtain the latest version of the device specification sheets before using any SHARP's device."

■ Electrical Characteristics

(Unless otherwise specified, condition shall be $V_{IN}=15V$, $V_O=10V$, $I_O=0.5A$, $R_1=390\Omega$, $T_a=25^\circ C$)

Parameter	Symbol	Conditions	MIN.	TYP.	MAX.	Unit
Input voltage	V_{IN}	-	4.5	-	35	V
Output voltage	V_O	-	1.5	-	30	V
Load regulation	R_{egL}	$I_O=5mA$ to 1A	-	0.3	1.0	%
Line regulation	R_{egI}	$V_{IN}=11$ to 28V	-	0.5	2.5	%
Ripple rejection	RR	Refer to Fig. 2	45	55	-	dB
Reference voltage	V_{ref}		1.225	1.25	1.275	V
Temperature coefficient of reference voltage	$T_c V_{ref}$	$T_j=0$ to $125^\circ C$, $I_O=5mA$	-	± 1.0	-	%
Dropout voltage	V_{i-o}	⁴ , $I_O=0.5A$	-	-	0.5	V
Quiescent current	I_q	$I_O=0$	-	-	7	mA
Overheat shut-down temperature	T_{sd}		110	130	150	$^\circ C$

⁴ Input voltage shall be the value when output voltage is 95% in comparison with the initial value.

Fig.1 Test Circuit

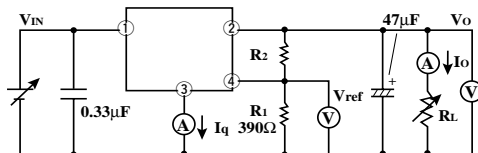

$$V_O = V_{ref} \times \left(1 + \frac{R_2}{R_1}\right) \approx 1.25 \times \left(1 + \frac{R_2}{R_1}\right)$$

[$R_1=390\Omega$, $V_{ref} \approx 1.25V$]

Fig.2 Test Circuit of Ripple Rejection

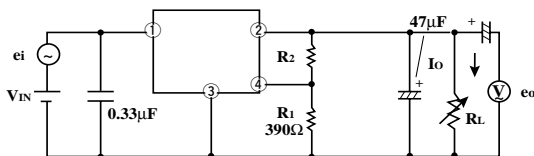

$I_O=0.5A$
 $f=120Hz$ (sine wave)
 $e_i=0.5V_{rms}$
 $RR=20 \log (e_i/e_o)$

Fig.3 Power Dissipation vs. Ambient Temperature

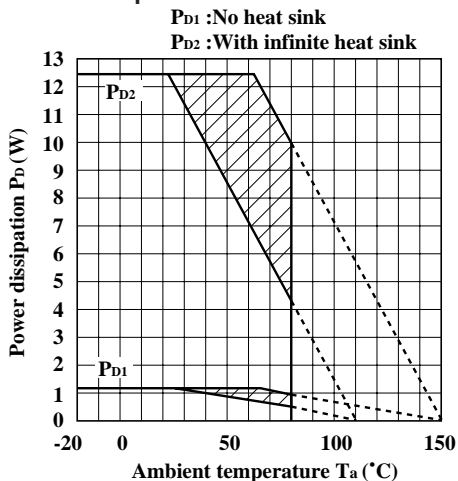

Note) Oblique line portion: Overheat protection operates in this area.

Fig.4 Overcurrent Protection Characteristics (Typical Value)

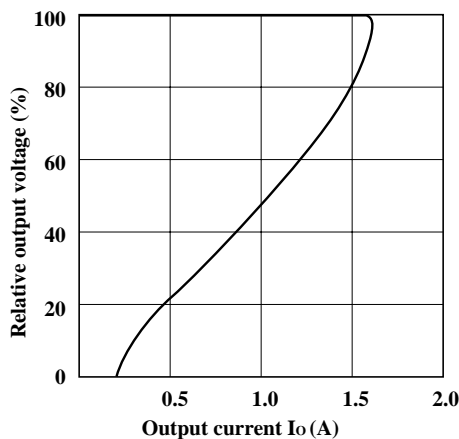

Fig.5 Output Voltage Adjustment Characteristics

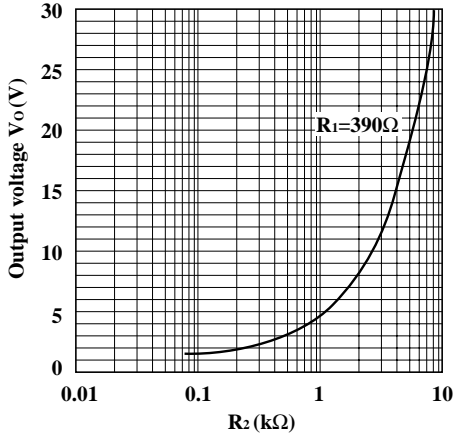

Fig.6 Output Voltage vs. Input Voltage

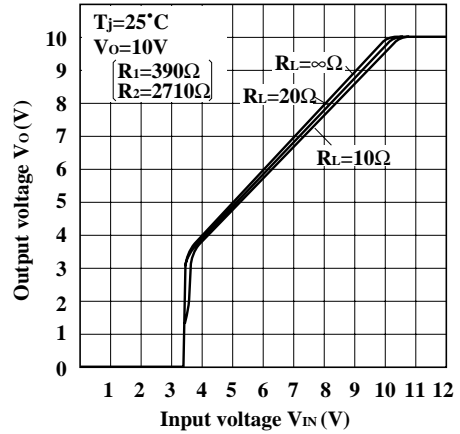

Fig.7 Dropout Voltage vs. Junction Temperature

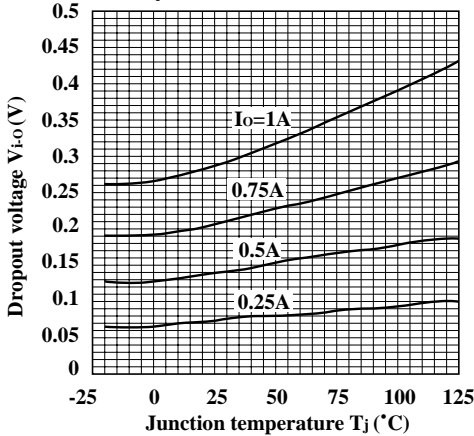

Fig.8 Circuit Operating Current vs. Input Voltage

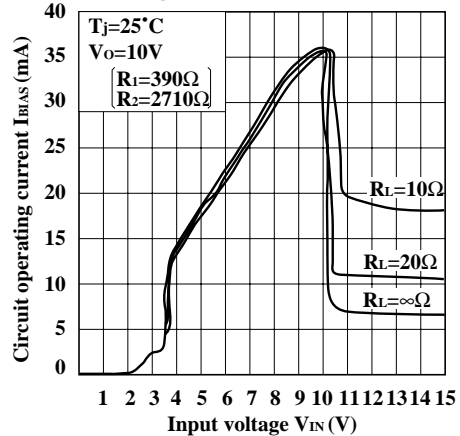
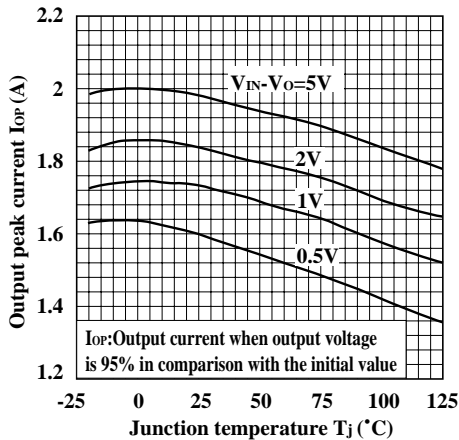
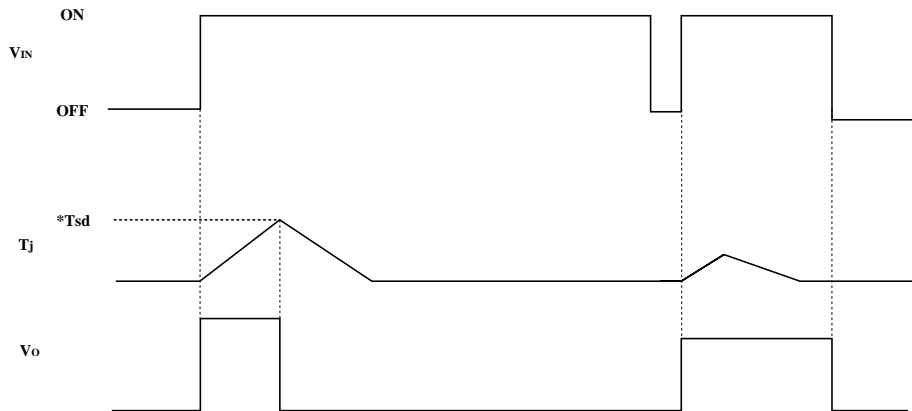

Fig.9 Output Peak Current vs. Junction Temperature



Overheat Shut-down Characteristics



* Tsd:Overheat shut-down temperature ($T_j \geq 110^\circ\text{C}$)
 1 Overheat shut-down operates at $T_j = T_{sd}$ and output OFF-state is maintained.
 2 OFF-state is kept until V_{IN} is once turned off.

ON/OFF Operation

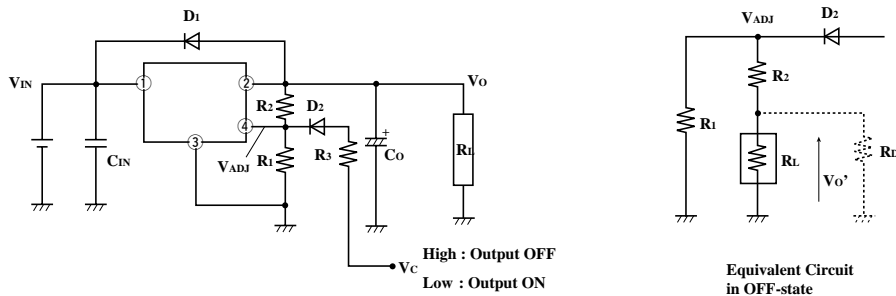

- ON/OFF operation is available by mounting externally D_2 and R_3 .
- When V_{ADJ} is forcibly raised above V_{ref} (1.25V TYP) by applying the external signal, the output is turned off (pass transistor of regulator is turned off). When the output is OFF, V_{ADJ} must be higher than $V_{ref} MAX.$, and at the same time must be lower than maximum rating 7V.
 In OFF-state, the load current flows to R_L from V_{ADJ} through R_2 . Therefore the value of R_2 must be as high as possible.
- $V_{O'} = V_{ADJ} \times R_L / (R_L + R_2)$
 occurs at the load. OFF-state equivalent circuit R_1 up to $10k\Omega$ is allowed. Select as high value of R_1 and R_2 as possible in this range. In some case, as output voltage is getting lower ($V_{O} < 1V$), impedance of load resistance rises. In such condition, it is sometime impossible to obtain the minimum value of $V_{O'}$. So add the dummy resistance indicated by R_D in the figure to the circuit parallel to the load.