

DATA SHEET

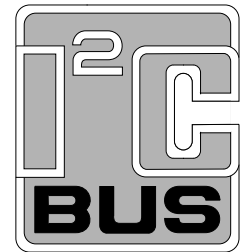

P89LPC932

80C51 8-bit microcontroller with two-clock core
8 KB 3 V low-power Flash with 512-byte data EEPROM

Preliminary data

2002 Oct 21

80C51 8-bit microcontroller with two-cycle instructions**P89LPC932****8KB Flash with 512 Byte Data EEPROM and 768 Byte RAM****Table of Contents**

General Description	6
Features	6
Ordering Information	7
Logic symbol	7
Block diagram	8
Pin Configuration	9
Pin Descriptions	10
Special Function Registers	12
Special Function Registers Table	13
Functional Description	17
Enhanced CPU	17
Clocks	17
Clock Definitions	17
CPU Clock (OSCCLK)	17
Low Speed Oscillator Option	17
Medium Speed Oscillator Option	17
High Speed Oscillator Option	17
Clock Output	17
On-Chip RC oscillator Option	17
Watchdog Oscillator Option	18
External Clock Input Option	18
CPU Clock (CCLK) Wakeup Delay	18
CPU Clock (CCLK) Modification: DIVM Register	18
Low Power Select	19
Memory Organization	19
Data RAM Arrangement	19
Interrupts	19
External interrupt inputs	20
I/O Ports	21
Port configurations	21
Quasi-bidirectional output configuration	21
Open drain output configuration	21
Input-only configuration	21
Push-pull output configuration	21
Port 0 analog functions	22
Additional Port Features	22
Power Monitoring Functions	22
Brownout detection	22

80C51 8-bit microcontroller with two-cycle instructions		P89LPC932
8KB Flash with 512 Byte Data EEPROM and 768 Byte RAM		
Power-on Detection		22
Power Reduction Modes		22
Reset		23
Reset vector		23
Timers/Counters 0 and 1		23
Mode 0		24
Mode 1		24
Mode 2		24
Mode 3		24
Mode 6		24
Timer overflow toggle output		24
Real-Time Clock/System Timer		24
Capture/Compare Unit (CCU)		24
CCU clock (CCUCLK)		24
CCU clock prescaling		24
Basic timer operation		25
Output compare		25
Input capture		25
PWM operation		25
Alternating Output Mode		26
PLL operation		26
CCU interrupts		27
UART		27
Mode 0		27
Mode 1		27
Mode 2		27
Mode 3		28
Baud rate generator and selection		28
Framing error		28
Break detect		28
Double buffering		28
Transmit interrupts with double buffering enabled (Modes 1, 2 and 3)		28
The 9th bit (Bit 8) in double buffering (Modes 1, 2 and 3)		28
I2C Serial Interface		29
Serial Peripheral Interface (SPI)		31
Typical SPI configurations		32
Analog Comparators		33
Internal reference voltage		33
Comparator interrupt		33
Comparators and Power Reduction Modes		34
Keypad Interrupt (KBI)		34
Watchdog Timer		35
Additional Features		36
Software Reset		36
Dual Data Pointers		36

80C51 8-bit microcontroller with two-cycle instructions**P89LPC932****8KB Flash with 512 Byte Data EEPROM and 768 Byte RAM**

Data EEPROM	36
Flash Program Memory	36
General description	36
Features	36
ISP and IAP capabilities of the LPC932	37
Flash organization	37
Flash programming and erasing	37
Boot ROM	37
Power-on Reset code execution	37
Hardware activation of the Boot Loader	37
In-System Programming (ISP)	37
In-Application Programming method (IAP)	38
User Configuration Bytes	38
User Sector Security Bytes	38
Absolute Maximum Ratings	39
DC Electrical Characteristics	40
AC Electrical Characteristics	42
Comparator Electrical Characteristics	46
AC Characteristics, ISP ENTRY MODE	47
Package outline	48
Data sheet status	50
Definitions	50
Disclaimers	50
Licences	50
Contact information	51

List of Figures

Logic symbol.	7
Block diagram.. . . .	8
28-pin TSSOP package	9
TSSOP28 pin configuration.	9
28-pin PLCC package	9
PLCC28 pin configuration.	9
Block diagram of oscillator control.	18
Interrupt sources, interrupt enables, and power-down wake-up sources	20
Asymmetrical PWM, downcounting.	25
Symmetrical PWM.	26
Alternate output mode.	26
Capture/Compare Unit interrupts	27
Baud rate sources for UART (Modes 1, 3)	28
I2C-bus configuration	29
I2C-bus serial interface block diagram	30
SPI block diagram	31
SPI single master single slave configuration.	32
SPI dual device configuration, where either can be a master or a slave.	32
SPI single master multiple slaves configuration	33
Comparator input and output connections	34
Watchdog timer in Watchdog mode (WDTE = 1)	35
SPI Master timing (CPHA = 0)	43
SPI Master timing (CPHA = 1)	44
SPI Slave timing (CPHA = 0)	44
SPI Slave timing (CPHA = 1)	45
Shift Register Mode timing	46
External clock timing	46
ISP Entry waveform.	47

80C51 8-bit microcontroller with two-clock core
8 KB 3 V low-power Flash with 512-byte data EEPROM**P89LPC932**

GENERAL DESCRIPTION

The P89LPC932 is a single-chip microcontroller designed for applications demanding high-integration, low cost solutions over a wide range of performance requirements. The P89LPC932 is based on a high performance processor architecture that executes instructions in two to four clocks, six times the rate of standard 80C51 devices. Many system level functions have been incorporated into the P89LPC932 in order to reduce component count, board space, and system cost.

FEATURES

- A high performance 80C51 CPU provides instruction cycle times of 167-333 ns for all instructions except multiply and divide when executing at 12 MHz. This is 6 times the performance of the standard 80C51 running at the same clock frequency. A lower clock frequency for the same performance results in power savings and reduced EMI.
- 2.4 V to 3.6 V V_{DD} operating range. I/O pins are 5 V tolerant (may be pulled up or driven to 5.5 V).
- 8 KB Flash code memory with 1 KB erasable sectors and 64-byte erasable page size.
- 256-byte RAM data memory. 512-byte auxiliary on-chip RAM.
- 512-byte customer Data EEPROM on chip allows serialization of devices, storage of set-up parameters, etc.
- Two 16-bit counter/timers. Each timer may be configured to toggle a port output upon timer overflow or to become a PWM output.
- Real-Time clock that can also be used as a system timer.
- Capture/Compare Unit (CCU) provides PWM, input capture, and output compare functions.
- Two analog comparators with selectable inputs and reference source.
- Enhanced UART with fractional baudrate generator, break detect, framing error detection, automatic address detection and versatile interrupt capabilities.
- 400 kHz byte-wide I²C communication port.
- SPI communication port.
- Eight keypad interrupt inputs, plus two additional external interrupt inputs.
- Four interrupt priority levels.
- Watchdog timer with separate on-chip oscillator, requiring no external components. The watchdog time-out time is selectable from 8 values.
- Active-LOW reset. On-chip power-on reset allows operation without external reset components. A reset counter and reset glitch suppression circuitry prevent spurious and incomplete resets. A software reset function is also available.
- Low voltage reset (Brownout detect) allows a graceful system shut-down when power fails. May optionally be configured as an interrupt.
- Oscillator Fail Detect. The watchdog timer has a separate fully on-chip oscillator allowing it to perform an oscillator fail detect function.
- Configurable on-chip oscillator with frequency range and RC oscillator options (selected by user programmed Flash configuration bits). The RC oscillator option allows operation without external oscillator components. Oscillator options support frequencies from 20 kHz to the maximum operating frequency of 12 MHz. The RC oscillator option is selectable and fine tunable.
- Programmable port output configuration options: quasi-bidirectional, open drain, push-pull, input-only.
- Port "input pattern match" detect. Port 0 may generate an interrupt when the value of the pins match or do not match a programmable pattern.
- Second data pointer.
- Schmitt trigger port inputs.
- LED drive capability (20 mA) on all port pins. A maximum limit is specified for the entire chip.
- Controlled slew rate port outputs to reduce EMI. Outputs have approximately 10 ns minimum ramp times.
- 23 I/O pins minimum (28-pin package). Up to 26 I/O pins while using on-chip oscillator and reset options.
- Only power and ground connections are required to operate the LPC932 when on-chip oscillator and reset options are selected.
- Serial Flash programming allows simple in-circuit production coding. Flash security bits prevent reading of sensitive application programs.

80C51 8-bit microcontroller with two-clock core
8 KB 3 V low-power Flash with 512-byte data EEPROM

P89LPC932

- In-Application Programming of the Flash code memory. This allows changing the code in a running application.
- Idle and two different Power down reduced power modes. Improved wakeup from Power down mode (a low interrupt input starts execution). Typical Power down current is 1µA (total Power down with voltage comparators disabled).
- 28-pin PLCC and TSSOP packages.
- Emulation support.

ORDERING INFORMATION

Part Number	Package	Temperature Range	Frequency	Drawing Number
P89LPC932BA	PLCC28: plastic leaded chip carrier; 28 leads	0 to +70 °C	0-12 MHz	SOT261-2
P89LPC932BDH	TSSOP28: plastic thin shrink small outline package; 28 leads; body width 4.4 mm	0 to +70 °C	0-12 MHz	SOT361-1

LOGIC SYMBOL

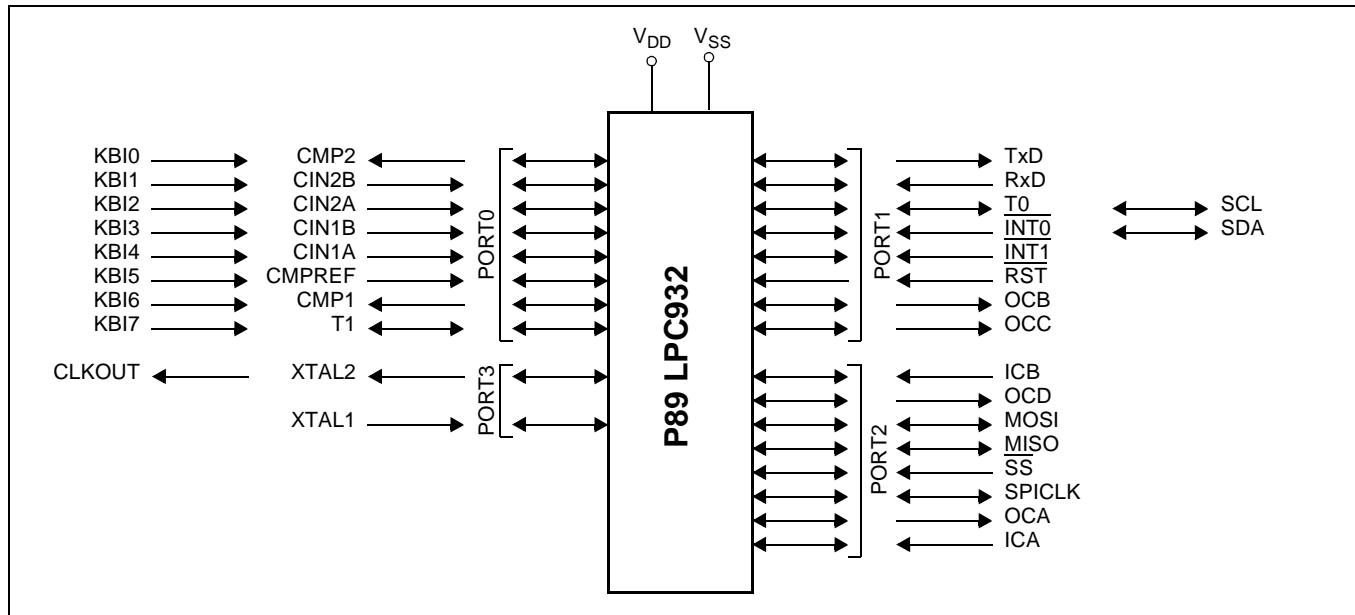

Figure 1: Logic symbol.

BLOCK DIAGRAM

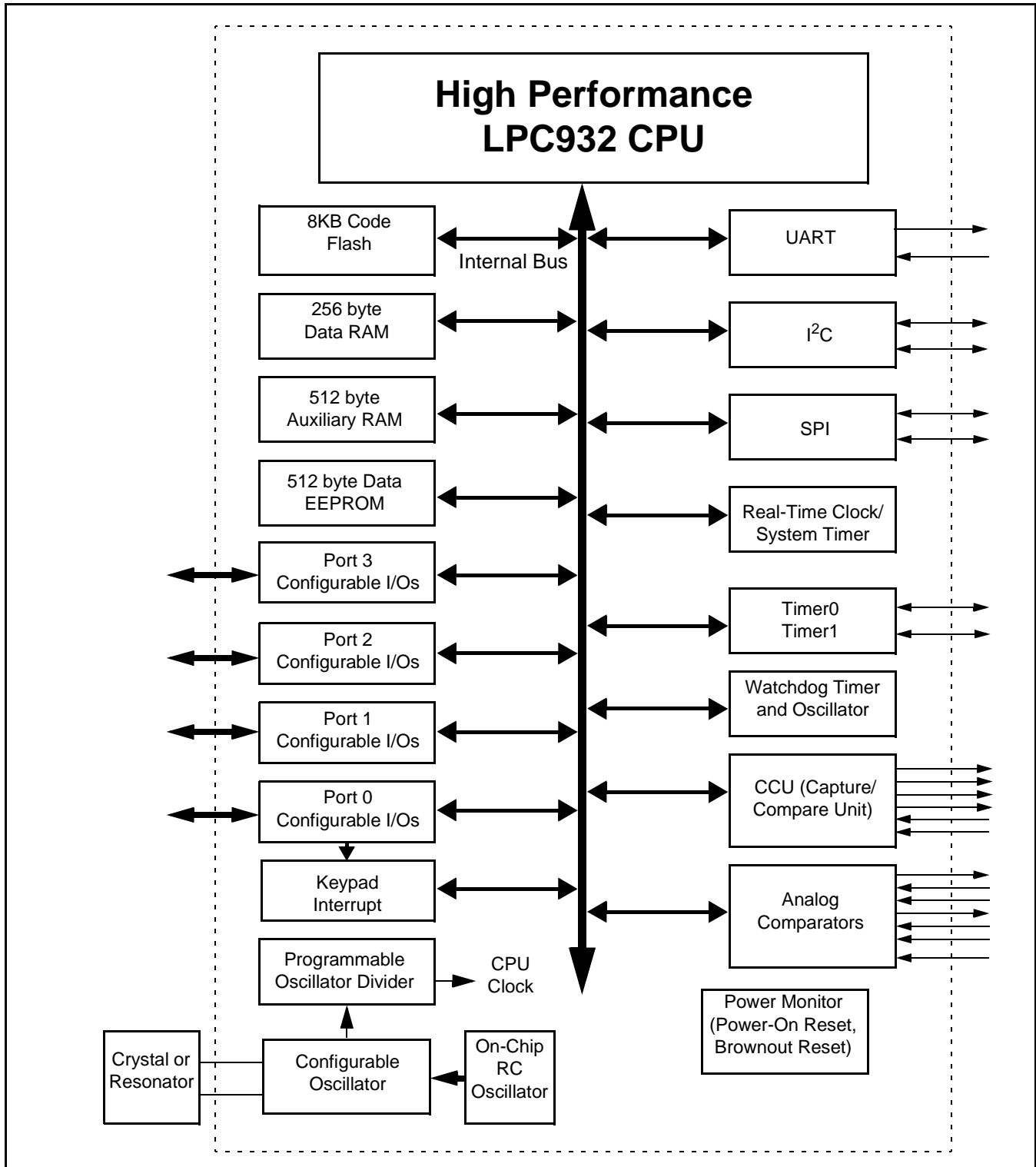

Figure 2: Block diagram.

80C51 8-bit microcontroller with two-clock core
8 KB 3 V low-power Flash with 512-byte data EEPROM

P89LPC932

PIN CONFIGURATION

28-pin TSSOP package

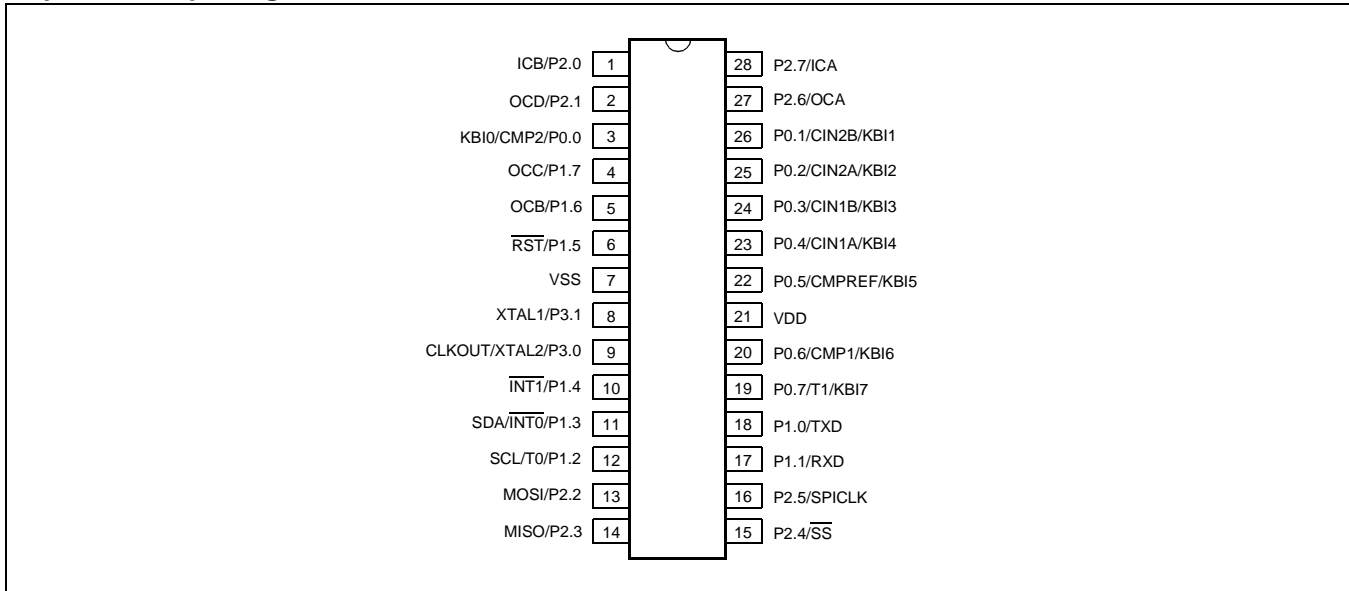

Figure 3: TSSOP28 pin configuration.

28-pin PLCC package

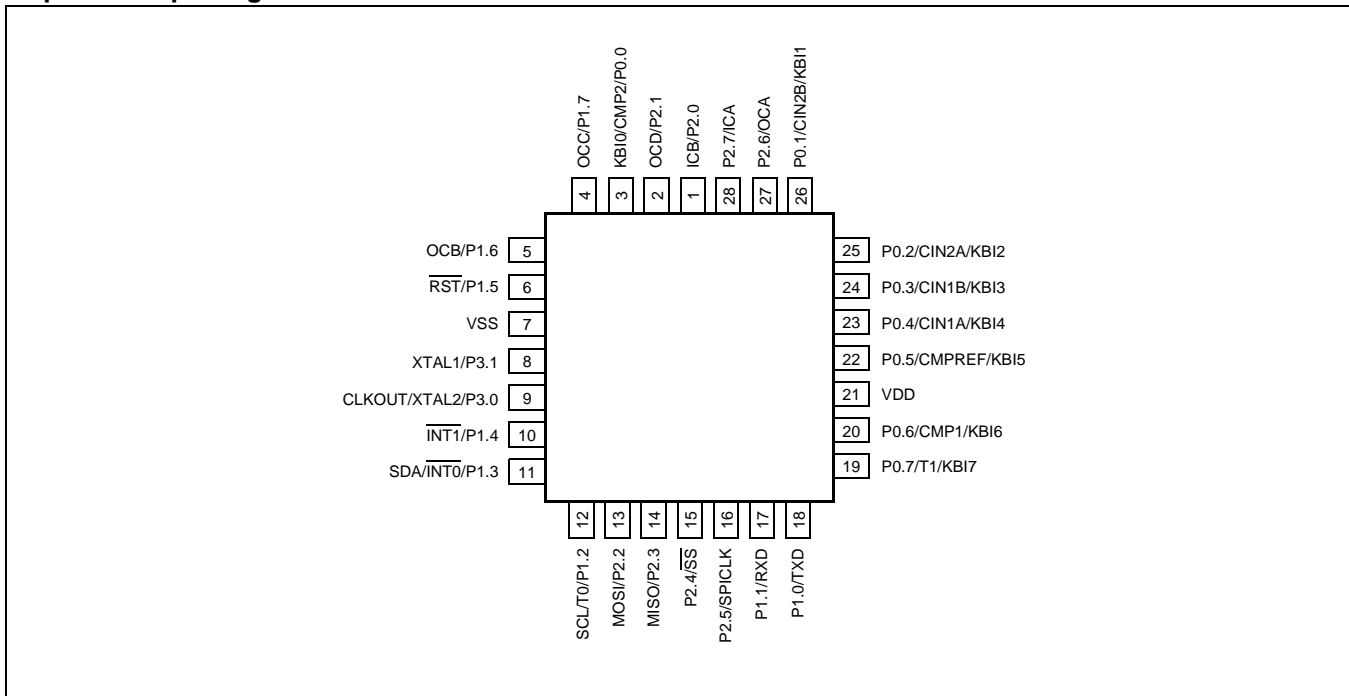

Figure 4: PLCC28 pin configuration.

80C51 8-bit microcontroller with two-clock core**P89LPC932****8 KB 3 V low-power Flash with 512-byte data EEPROM****PIN DESCRIPTIONS**

MNEMONIC	PIN NO. for TSSOP28/PLCC28	TYPE	NAME AND FUNCTION
P0.0 - P0.7	3, 26, 25, 24, 23, 22, 20, 19	I/O	<p>Port 0: Port 0 is an 8-bit I/O port with a user-configurable output type. During reset Port 0 latches are configured in the input only mode with the internal pullup disabled. The operation of port 0 pins as inputs and outputs depends upon the port configuration selected. Each port pin is configured independently. Refer to the section on I/O port configuration and the DC Electrical Characteristics for details.</p> <p>The Keypad Interrupt feature operates with port 0 pins.</p> <p>All pins have Schmitt triggered inputs.</p> <p>Port 0 also provides various special functions as described below.</p>
	3	I/O O I	<p>P0.0 Port 0 bit 0.</p> <p>CMP2 Comparator 2 output.</p> <p>KBI0 Keyboard Input 0.</p>
	26	I/O I I	<p>P0.1 Port 0 bit 1.</p> <p>CIN2B Comparator 2 positive input B.</p> <p>KBI1 Keyboard Input 1.</p>
	25	I/O I I	<p>P0.2 Port 0 bit 2.</p> <p>CIN2A Comparator 2 positive input A.</p> <p>KBI2 Keyboard Input 2.</p>
	24	I/O I I	<p>P0.3 Port 0 bit 3.</p> <p>CIN1B Comparator 1 positive input B.</p> <p>KBI3 Keyboard Input 3.</p>
	23	I/O I I	<p>P0.4 Port 0 bit 4.</p> <p>CIN1A Comparator 1 positive input A.</p> <p>KBI4 Keyboard Input 4.</p>
	22	I/O I I	<p>P0.5 Port 0 bit 5.</p> <p>CMPREF Comparator reference (negative) input.</p> <p>KBI5 Keyboard Input 5.</p>
	20	I/O O I	<p>P0.6 Port 0 bit 6.</p> <p>CMP1 Comparator 1 output.</p> <p>KBI6 Keyboard Input 6.</p>
	19	I/O I/O I	<p>P0.7 Port 0 bit 7.</p> <p>T1 Timer/counter 1 external count input or overflow output.</p> <p>KBI7 Keyboard Input 7.</p>
P1.0 - P1.7	18, 17, 12, 11, 10, 6, 5, 4	I/O (for P1.0-P1.4, P1.6-P1.7); I (for P1.5)	<p>Port 1: Port 1 is an 8-bit I/O port with a user-configurable output type, except for three pins as noted below. During reset Port 1 latches are configured in the input only mode with the internal pullup disabled. The operation of the configurable port 1 pins as inputs and outputs depends upon the port configuration selected. Each of the configurable port pins are programmed independently. Refer to the section on I/O port configuration and the DC Electrical Characteristics for details. P1.2 - P1.3 are open drain when used as outputs. P1.5 is input only.</p> <p>All pins have Schmitt triggered inputs.</p> <p>Port 1 also provides various special functions as described below.</p>
	18	I/O O	<p>P1.0 Port 1 bit 0.</p> <p>TxD Transmitter output for the serial port.</p>
	17	I/O I	<p>P1.1 Port 1 bit 1.</p> <p>RxD Receiver input for the serial port.</p>

80C51 8-bit microcontroller with two-clock core**P89LPC932****8 KB 3 V low-power Flash with 512-byte data EEPROM**

MNEMONIC	PIN NO. for TSSOP28/ PLCC28	TYPE	NAME AND FUNCTION
	12	I/O I/O I/O	P1.2 Port 1 bit 2. (Open-drain when used as an output) T0 Timer/counter 0 external count input or overflow output. (Open-drain when used as outputs) SCL I ² C serial clock input/output.
	11	I I I/O	P1.3 Port 1 bit 3. (Open-drain when used as an output) INT0 External interrupt 0 input. SDA I ² C serial data input/output.
	10	I I	P1.4 Port 1 bit 4. INT1 External interrupt 1 input.
	6	I I	P1.5 Port 1 bit 5. (Input only) RST External Reset input during power-on or if selected via UCFG1. When functioning as a reset input a low on this pin resets the microcontroller, causing I/O ports and peripherals to take on their default states, and the processor begins execution at address 0. Also used during a power-on sequence to force In-System Programming mode.
	5	I/O O	P1.6 Port 1 bit 6. OCB Output Compare B.
	4	I/O O	P1.7 Port 1 bit 7. OCC Output Compare C.
P2.0 - P2.7	1, 2, 13, 14, 15, 16, 27, 28	I/O	Port 2: Port 2 is a 8-bit I/O port with a user-configurable output type. During reset Port 2 latches are configured in the input only mode with the internal pullup disabled. The operation of port 2 pins as inputs and outputs depends upon the port configuration selected. Each port pin is configured independently. Refer to the section on I/O port configuration and the DC Electrical Characteristics for details. This port is not available in 20-pin package and is configured automatically as outputs to conserve power. The alternate functions for these pins must not be enabled. All pins have Schmitt triggered inputs. Port 2 also provides various special functions as described below.
	1	I/O I	P2.0 Port 2 bit 0. ICB Input capture B.
	2	I/O O	P2.1 Port 2 bit 1. OCD Output compare D.
	13	I/O I/O	P2.2 Port 2 bit 2. MOSI SPI master out slave in. When configured as master, this pin is output, when configured as slave, this pin is input.
	14	I/O I/O	P2.3 Port 2 bit 3. MISO SPI master in slave out. When configured as master, this pin is input, when configured as slave, this pin is output.
	15	I/O I	P2.4 Port 2 bit 4. SS SPI Slave select.
	16	I/O I/O	P2.5 Port 2 bit 5. SPICLK SPI clock. When configured as master, this pin is output, when configured as slave, this pin is input. (Not available in 20-pin package)
	27	I/O O	P2.6 Port 2 bit 6. OCA Output compare A
	28	I/O I	P2.7 Port 2 bit 7. ICA Input capture A

80C51 8-bit microcontroller with two-clock core**P89LPC932****8 KB 3 V low-power Flash with 512-byte data EEPROM**

MNEMONIC	PIN NO. for TSSOP28/PLCC28	TYPE	NAME AND FUNCTION
P3.0 - P3.1	9, 8	I/O	Port 3: Port 3 is an 2-bit I/O port with a user-configurable output type. During reset Port 3 latches are configured in the input only mode with the internal pullup disabled. The operation of port 3 pins as inputs and outputs depends upon the port configuration selected. Each port pin is configured independently. Refer to the section on I/O port configuration and the DC Electrical Characteristics for details. All pins have Schmitt triggered inputs. Port 3 also provides various special functions as described below:
	9	I/O O O	P3.0 Port 3 bit 0. XTAL2 Output from the oscillator amplifier (when a crystal oscillator option is selected via the FLASH configuration). CLKOUT CPU clock divided by 2 when enabled via SFR bit (ENCLK - TRIM.6). It can be used if the CPU clock is the internal RC oscillator, watchdog oscillator or external clock input, except when XTAL1/XTAL2 are used to generate clock source for the Real-Time clock/system timer.
	8	I/O I	P3.1 Port 3 bit 1. XTAL1 Input to the oscillator circuit and internal clock generator circuits (when selected via the FLASH configuration). It can be a port pin if internal RC oscillator or watchdog oscillator is used as the CPU clock source, AND if XTAL1/XTAL2 are not used to generate the clock for the Real-Time clock/system timer.
V _{SS}	7	I	Ground: 0 V reference.
V _{DD}	21	I	Power Supply: This is the power supply voltage for normal operation as well as Idle and Power down modes.

SPECIAL FUNCTION REGISTERS**Note: Special Function Registers (SFRs) accesses are restricted in the following ways:**

- User must NOT attempt to access any SFR locations not defined.
- Accesses to any defined SFR locations must be strictly for the functions for the SFRs.
- SFR bits labeled '-', '0' or '1' can ONLY be written and read as follows:
 - '-' Unless otherwise specified, MUST be written with '0', but can return any value when read (even if it was written with '0'). It is a reserved bit and may be used in future derivatives.
 - '0' MUST be written with '0', and will return a '0' when read.
 - '1' MUST be written with '1', and will return a '1' when read.

80C51 8-bit microcontroller with two-clock core
8 KB 3 V low-power Flash with 512-byte data EEPROM

P89LPC932

SPECIAL FUNCTION REGISTERS TABLE

Name	Description	SFR Address	Bit Functions and Addresses								Reset Value			
			MSB								LSB		Hex	Binary
ACC*	Accumulator	E0H	E7	E6	E5	E4	E3	E2	E1	E0			00H	00000000
AUXR1#	Auxiliary Function Register	A2H	CLKLP	EBRR	ENT1	ENT0	SRST	0	-	DPS			00H ¹	000000x0
B*	B Register	F0H	F7	F6	F5	F4	F3	F2	F1	F0			00H	00000000
BRGR0#§	Baud Rate Generator Rate Low	BEH											00H	00000000
BRGR1#§	Baud Rate Generator Rate High	BFH											00H	00000000
BRGCON#	Baud Rate Generator Control	BDH	-	-	-	-	-	-	SBRGS	BRGEN			00H ⁶	xxxxxx00
CCCR A#	Capture Compare A Control Register	EAH	ICECA2	ICECA1	ICECA0	ICESA	ICNFA	FCOA	OCMA1	OCMA0			00H	00000000
CCCR B#	Capture Compare B Control Register	EBH	ICECB2	ICECB1	ICECB0	ICESB	ICNFB	FCOB	OCMB1	OCMB0			00H	00000000
CCCR C#	Capture Compare C Control Register	ECH	-	-	-	-	-	FCOC	OCMC1	OCMC0			00H	xxxxx000
CCCR D#	Capture Compare D Control Register	EDH	-	-	-	-	-	FCOD	OCMD1	OCMD0			00H	xxxxx000
CMP1#	Comparator 1 Control Register	ACH	-	-	CE1	CP1	CN1	OE1	CO1	CMF1			00H ¹	xx000000
CMP2#	Comparator 2 Control Register	ADH	-	-	CE2	CP2	CN2	OE2	CO2	CMF2			00H ¹	xx000000
DEECON#	Data EEPROM Control Register	F1H	EEIF	HVERR	ECTL1	ECTL0	-	-	-	EADR8			0EH	00001110
DEEDAT#	Data EEPROM Data Register	F2H											00H	00000000
DEEADR#	Data EEPROM Address Register	F3H											00H	00000000
DIVM#	CPU Clock Divide-by-M Control	95H											00H	00000000
DPTR	Data Pointer (2 bytes)													
DPH	Data Pointer High	83H											00H	00000000
DPL	Data Pointer Low	82H											00H	00000000
I2ADR#	I ² C Slave Address Register	DBH	I2ADR.6	I2ADR.5	I2ADR.4	I2ADR.3	I2ADR.2	I2ADR.1	I2ADR.0	GC			00H	00000000
I2CON*#	I ² C Control Register	D8H	DF	DE	DD	DC	DB	DA	D9	D8			00H	x00000x0
I2DAT#	I ² C Data Register	DAH												
I2SCLH#	Serial Clock Generator/SCL Duty Cycle Register High	DDH											00H	00000000
I2SCLL#	Serial Clock Generator/SCL Duty Cycle Register Low	DCH											00H	00000000

80C51 8-bit microcontroller with two-clock core

P89LPC932

8 KB 3 V low-power Flash with 512-byte data EEPROM

Name	Description	SFR Address	Bit Functions and Addresses								Reset Value	
			MSB				LSB				Hex	Binary
I2STAT#	I ² C Status Register	D9H	STA.4	STA.3	STA.2	STA.1	STA.0	0	0	0	F8H	11111000
ICRAH#	Input Capture A Register High	ABH									00H	
ICRAL#	Input Capture A Register low	AAH									00H	00000000
ICRBH#	Input Capture B Register High	AFH									00H	00000000
ICRBL#	Input Capture B Register Low	AEH									00H	00000000
IEN0*	Interrupt Enable 0	A8H	AF	AE	AD	AC	AB	AA	A9	A8	00H	00000000
			EA	EWDRT	EBO	ES/ESR	ET1	EX1	ET0	EX0		
IEN1*#	Interrupt Enable 1	E8H	EF	EE	ED	EC	EB	EA	E9	E8	00H ¹	00x000000
			EIEE	EST	-	ECCU	ESPI	EC	EKBI	EI2C		
IP0*	Interrupt Priority 0	B8H	BF	BE	BD	BC	BB	BA	B9	B8	00H ¹	x00000000
			-	PWDRT	PBO	PS/PSR	PT1	PX1	PT0	PX0		
IP0H#	Interrupt Priority 0 High	B7H	-	PWDRT H	PBOH	PSH/ PSRH	PT1H	PX1H	PT0H	PX0H	00H ¹	x00000000
			FF	FE	FD	FC	FB	FA	F9	F8		
IP1*#	Interrupt Priority 1	F8H	PIEE	PST	-	PCCU	PSPI	PC	PKBI	PI2C	00H ¹	00x000000
			PIEEH	PSTH	-	PCCUH	PSPIH	PCH	PKBIH	PI2CH		
IP1H#	Interrupt Priority 1 High	F7H	PIEEH	PSTH	-	PCCUH	PSPIH	PCH	PKBIH	PI2CH	00H ¹	00x000000
			-	-	-	-	-	-	PATN _SEL	KBIF		
KBCON#	Keypad Control Register	94H	-	-	-	-	-	-	PATN _SEL	KBIF	00H ¹	xxxxxx00
KBMASK#	Keypad Interrupt Mask Register	86H									00H	00000000
KBPATN#	Keypad Pattern Register	93H									FFH	11111111
OCRAH#	Output Compare A Register High	EFH									00H	00000000
OCRAL#	Output Compare A Register Low	EEH									00H	00000000
OCRBH#	Output Compare B Register High	FBH									00H	00000000
OCRBL#	Output Compare B Register Low	FAH									00H	00000000
OCRCH#	Output Compare C Register High	FDH									00H	00000000
OCRCL#	Output Compare C Register Low	FCH									00H	00000000
OCRDH#	Output Compare D Register High	FFH									00H	00000000
OCRDL#	Output Compare D Register Low	FEH									00H	00000000
P0*	Port 0	80H	87	86	85	84	83	82	81	80	Note 1	
			T1/KB7	CMP1/ KB6	CMPREF/ KB5	CIN1A/ KB4	CIN1B/ KB3	CIN2A/ KB2	CIN2B/ KB1	CMP2/ KB0		
P1*	Port 1	90H	97	96	95	94	93	92	91	90	Note 1	
			OCC	OCB	RST	INT1	INT0/ SDA	T0/SCL	RxD	TxD		

80C51 8-bit microcontroller with two-clock core
8 KB 3 V low-power Flash with 512-byte data EEPROM

P89LPC932

Name	Description	SFR Address	Bit Functions and Addresses								Reset Value	
			MSB				LSB				Hex	Binary
P2*	Port 2	A0H	A7	A6	A5	A4	A3	A2	A1	A0	Note 1	
			ICA	OCA	SPICLK	SS	MISO	MOSI	OCD	ICB		
P3*	Port 3	B0H	B7	B6	B5	B4	B3	B2	B1	B0	Note 1	
			-	-	-	-	-	-	XTAL1	XTAL2		
P0M1#	Port 0 Output Mode 1	84H	(P0M1.7)	(P0M1.6)	(P0M1.5)	(P0M1.4)	(P0M1.3)	(P0M1.2)	(P0M1.1)	(P0M1.0)	FFH	11111111
P0M2#	Port 0 Output Mode 2	85H	(P0M2.7)	(P0M2.6)	(P0M2.5)	(P0M2.4)	(P0M2.3)	(P0M2.2)	(P0M2.1)	(P0M2.0)	00H	00000000
P1M1#	Port 1 Output Mode 1	91H	(P1M1.7)	(P1M1.6)	-	(P1M1.4)	(P1M1.3)	(P1M1.2)	(P1M1.1)	(P1M1.0)	D3H ¹	11x1xx11
P1M2#	Port 1 Output Mode 2	92H	(P1M2.7)	(P1M2.6)	-	(P1M2.4)	(P1M2.3)	(P1M2.2)	(P1M2.1)	(P1M2.0)	00H ¹	00x0xx00
P2M1#	Port 2 Output Mode 1	A4H	(P2M1.7)	(P2M1.6)	(P2M1.5)	(P2M1.4)	(P2M1.3)	(P2M1.2)	(P2M1.1)	(P2M1.0)	FFH	11111111
P2M2#	Port 2 Output Mode 2	A5H	(P2M2.7)	(P2M2.6)	(P2M2.5)	(P2M2.4)	(P2M2.3)	(P2M2.2)	(P2M2.1)	(P2M2.0)	00H	00000000
P3M1#	Port 3 Output Mode 1	B1H	-	-	-	-	-	-	(P3M1.1)	(P3M1.0)	03H ¹	xxxxxx11
P3M2#	Port 3 Output Mode 2	B2H	-	-	-	-	-	-	(P3M2.1)	(P3M2.0)	00H ¹	xxxxxx00
PCON#	Power Control Register	87H	SMOD1	SMOD0	BOPD	BOI	GF1	GF0	PMOD1	PMOD0	00H	00000000
PCONA#	Power Control Register A	B5H	RTCPD	DEEPCD	VCPD		I2PD	SPPD	SPD	CCUPD	00H ¹	00000000
PSW*	Program Status Wword	D0H	D7	D6	D5	D4	D3	D2	D1	D0	00H 00000000	
			CY	AC	F0	RS1	RS0	OV	F1	P		
PT0AD#	Port 0 Digital Input Disable	F6H	-	-	PT0AD.5	PT0AD.4	PT0AD.3	PT0AD.2	PT0AD.1	-	00H	xx00000x
RSTSRC#	Reset Source Register	DFH	-	-	BOF	POF	R_BK	R_WD	R_SF	R_EX	Note 2	
RTCCON#	Real-Time Clock Control	D1H	RTCF	RTCS1	RTCS0	-	-	-	ERTC	RTCEN	60H ^{1,5}	011xxx00
RTCH#	Real-Time Clock Register High	D2H									00H ⁵	00000000
RTCL#	Real-Time Clock Register Low	D3H									00H ⁵	00000000
SADDR#	Serial Port Address Register	A9H									00H	00000000
SADEN#	Serial Port Address Enable	B9H									00H	00000000
SBUF	Serial Port Data Buffer Register	99H									xxH	xxxxxxxx
SCON*	Serial Port Control	98H	9F	9E	9D	9C	9B	9A	99	98	00H 00000000	
			SM0/FE	SM1	SM2	REN	TB8	RB8	TI	RI		
SSTAT#	Serial Port Extended Status Register	BAH	DBMOD	INTLO	CIDIS	DBISEL	FE	BR	OE	STINT	00H	00000000
SP	Stack Pointer	81H									07H	00000111
SPCTL#	SPI Control Register	E2H	SSIG	SPEN	DORD	MSTR	CPOL	CPHA	SPR1	SPR0	04H	00000100
SPSTAT#	SPI Status Register	E1H	SPIF	WCOL	-	-	-	-	-	-	00H	00xxxxxx

80C51 8-bit microcontroller with two-clock core
8 KB 3 V low-power Flash with 512-byte data EEPROM
P89LPC932

Name	Description	SFR Address	Bit Functions and Addresses								Reset Value	
			MSB				LSB				Hex	Binary
SPDAT#	SPI Data Register	E3H									00H	00000000
TAMOD#	Timer 0 and 1 Auxiliary Mode	8FH	-	-	-	T1M2	-	-	-	T0M2	00H	xxx0xxx0
TCON*	Timer 0 and 1 Control	88H	8F	8E	8D	8C	8B	8A	89	88	00H	00000000
			TF1	TR1	TF0	TR0	IE1	IT1	IE0	IT0		
TCR20*#	CCU Control Register 0	C8H	PLEEN	HLTRN	HLTEN	ALTCB	ALTAB	TDIR2	TMOD21	TMOD20	00H	00000000
TCR21#	CCU Control Register 1	F9H	TCOU2	-	-	-	PLLDV.3	PLLDV.2	PLLDV.1	PLLDV.0	00H	0xxx0000
TH0	Timer 0 High	8CH									00H	00000000
TH1	Timer 1 High	8DH									00H	00000000
TH2#	CCU Timer High	CDH									00H	00000000
TICR2#	CCU Interrupt Control Register	C9H	TOIE2	TOCIE2D	TOCIE2C	TOCIE2B	TOCIE2A	-	TICIE2B	TICIE2A	00H	00000x00
TIFR2#	CCU Interrupt Flag Register	E9H	TOIF2	TOCF2D	TOCF2C	TOCF2B	TOCF2A	-	TICF2B	TICF2A	00H	00000x00
TISE2#	CCU Interrupt Status Encode Register	DEH	-	-	-	-	-	ENCINT.2	ENCINT.1	ENCINT.0	00H	xxxxx000
TL0	Timer 0 Low	8AH									00H	00000000
TL1	Timer 1 Low	8BH									00H	00000000
TL2#	CCU Timer Low	CCH									00H	00000000
TMOD	Timer 0 and 1 Mode	89H	T1GATE	T1C/T	T1M1	T1M0	T0GATE	T0C/T	T0M1	T0M0	00H	00000000
TOR2H#	CCU Reload Register High	CFH									00H	00000000
TOR2L#	CCU Reload Register Low	CEH									00H	00000000
TPCR2H#	Prescaler Control Register High	CBH	-	-	-	-	-	-	TPCR2H.1	TPCR2H.0	00H	xxxxxx00
TPCR2L#	Prescaler Control Register Low	CAH	TPCR2L.7	TPCR2L.6	TPCR2L.5	TPCR2L.4	TPCR2L.3	TPCR2L.2	TPCR2L.1	TPCR2L.0	00H	00000000
TRIM#	Internal Oscillator Trim Register	96H	-	ENCLK	TRIM.5	TRIM.4	TRIM.3	TRIM.2	TRIM.1	TRIM.0	Notes 4,5	
WDCON#	Watchdog Control Register	A7H	PRE2	PRE1	PRE0	-	-	WDRUN	WDTOF	WDCLK	Notes 3,5	
WDL#	Watchdog Load	C1H									FFH	11111111
WFEEED1#	Watchdog Feed 1	C2H										
WFEEED2#	Watchdog Feed 2	C3H										

Notes:

* SFRs are bit addressable.

SFRs are modified from or added to the 80C51 SFRs.

- Reserved bits, must be written with 0's.

§ BRGR1 and BRGR0 must only be written if BRGEN in BRGCON SFR is '0'. If any of them is written if BRGEN = 1, result is unpredictable. Unimplemented bits in SFRs (labeled '-') are X (unknown) at all times. Unless otherwise specified, ones should not be written to these bits since they may be used for other purposes in future derivatives. The reset values shown for these bits are '0's although they are unknown when read.

- All ports are in input only (high impedance) state after power-up.
- The RSTSRC register reflects the cause of the LPC932 reset. Upon a power-up reset, all reset source flags are cleared except POF and BOF - the power-on reset value is xx110000.
- After reset, the value is 111001x1, i.e., PRE2-PRE0 are all 1, WDRUN=1 and WDCLK=1. WDTOF bit is 1 after watchdog reset and is 0 after power-on reset. Other resets will not affect WDTOF.
- On power-on reset, the TRIM SFR is initialized with a factory preprogrammed value. Other resets will not cause initialization of the TRIM register.
- The only reset source that affects these SFRs is power-on reset.

80C51 8-bit microcontroller with two-clock core
8 KB 3 V low-power Flash with 512-byte data EEPROM

P89LPC932

FUNCTIONAL DESCRIPTION

(Please refer to the LPC932 User's Manual for a more detailed functional description).

ENHANCED CPU

The LPC932 uses an enhanced 80C51 CPU which runs at 6 times the speed of standard 80C51 devices. A machine cycle consists of two CPU clock cycles, and most instructions execute in one or two machine cycles.

CLOCKS

Clock Definitions

The LPC932 device has several internal clocks as defined below:

- OSCCLK - Input to the DIVM clock divider. OSCCLK is selected from one of four clock sources (see Figure 5) and can also be optionally divided to a slower frequency (see section "CPU Clock (CCLK) Modification: DIVM Register"). **Note:** f_{OSC} is defined as the OSCCLK frequency.
- CCLK - CPU clock; output of the clock divider. There are two CCLK cycles per machine cycle, and most instructions are executed in one to two machine cycles (two or four CCLK cycles).
- RCCLK - The internal 7.373 MHz RC oscillator output.
- PCLK - Clock for the various peripheral devices and is CCLK/2

CPU Clock (OSCCLK)

The LPC932 provides several user-selectable oscillator options in generating the CPU clock. This allows optimization for a range of needs from high precision to lowest possible cost. These options are configured when the FLASH is programmed and include an on-chip watchdog oscillator, an on-chip RC oscillator, an oscillator using an external crystal, or an external clock source. The crystal oscillator can be optimized for low, medium, or high frequency crystals covering a range from 20 kHz to 12 MHz.

Low Speed Oscillator Option

This option supports an external crystal in the range of 20 kHz to 100 kHz. Ceramic resonators are also supported in this configuration.

Medium Speed Oscillator Option

This option supports an external crystal in the range of 100 kHz to 4 MHz. Ceramic resonators are also supported in this configuration.

High Speed Oscillator Option

This option supports an external crystal in the range of 4 MHz to 12 MHz. Ceramic resonators are also supported in this configuration.

Clock Output

The LPC932 supports a user selectable clock output function on the XTAL2 / CLKOUT pin when crystal oscillator is not being used. This condition occurs if another clock source has been selected (on-chip RC oscillator, watchdog oscillator, external clock input on X1) and if the Real-Time clock is not using the crystal oscillator as its clock source. This allows external devices to synchronize to the LPC932. This output is enabled by the ENCLK bit in the TRIM register

The frequency of this clock output is $1/2$ that of the CCLK. If the clock output is not needed in Idle mode, it may be turned off prior to entering Idle, saving additional power.

ON-CHIP RC OSCILLATOR OPTION

The LPC932 has a 6-bit TRIM register that can be used to tune the frequency of the RC oscillator. During reset, the TRIM value is initialized to a factory pre-programmed value to adjust the oscillator frequency to 7.373 MHz, $\pm 2.5\%$. End user applications can write to the Trim register to adjust the on-chip RC oscillator to other frequencies.

80C51 8-bit microcontroller with two-clock core**P89LPC932****8 KB 3 V low-power Flash with 512-byte data EEPROM****WATCHDOG OSCILLATOR OPTION**

The watchdog has a separate oscillator which has a frequency of 400 kHz. This oscillator can be used to save power when a high clock frequency is not needed.

EXTERNAL CLOCK INPUT OPTION

In this configuration, the processor clock is derived from an external source driving the XTAL1 / P3.1 pin. The rate may be from 0 Hz up to 12 MHz. The XTAL2/P3.0 pin may be used as a standard port pin or a clock output.

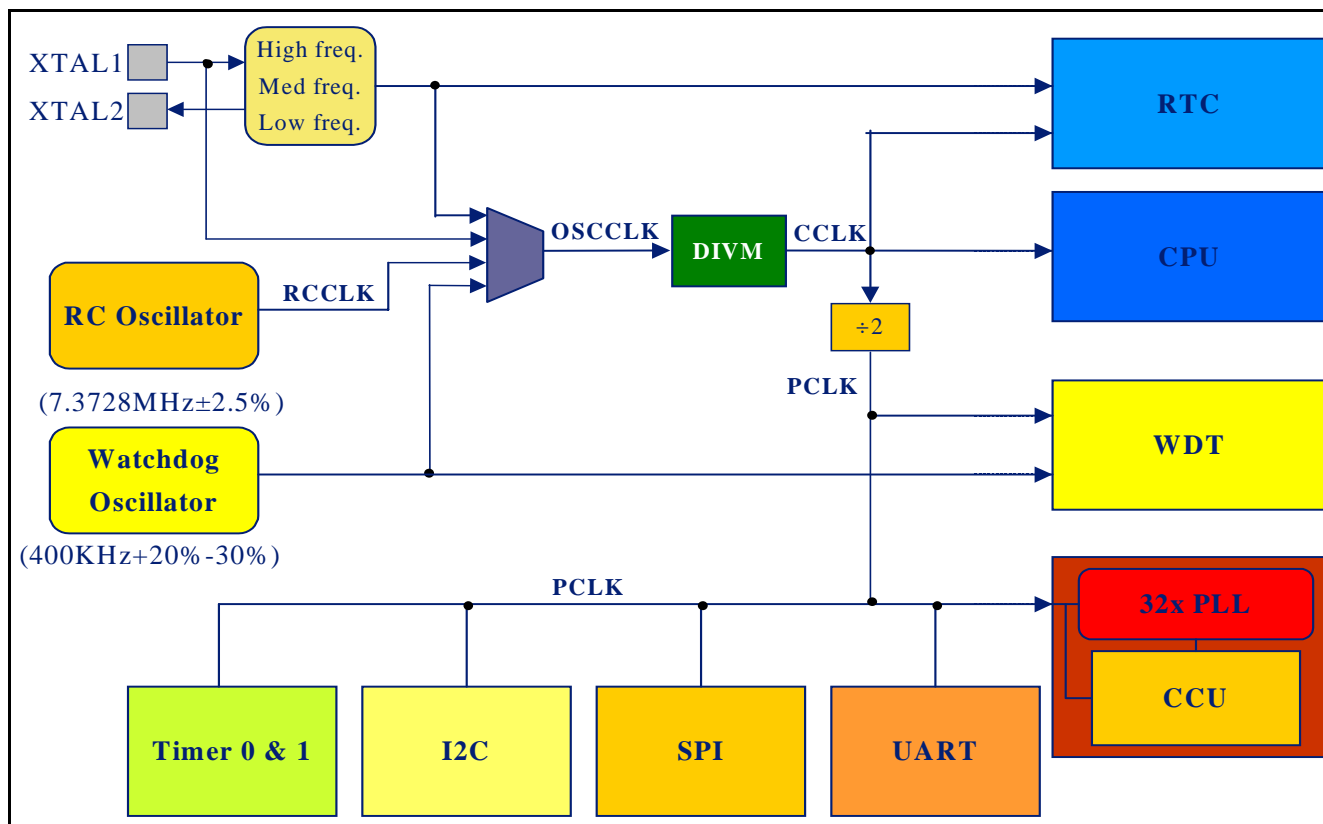

Figure 5: Block diagram of oscillator control

CPU CLOCK (CCLK) WAKEUP DELAY

The LPC932 has an internal wakeup timer that delays the clock until it stabilizes depending to the clock source used. If the clock source is any of the three crystal selections (low, medium and high frequencies) the delay is 992 OSCCLK cycles plus 60-100 μ s. If the clock source is either the internal RC oscillator, watchdog oscillator, or external clock, the delay is 224 OSCCLK cycles plus 60-100 μ s.

CPU CLOCK (CCLK) MODIFICATION: DIVM REGISTER

The OSCCLK frequency can be divided down up to 256 times by configuring a dividing register, DIVM, to generate CCLK. This feature makes it possible to temporarily run the CPU at a lower rate, reducing power consumption. By dividing the clock, the CPU can retain the ability to respond to events that would not exit Idle mode by executing its normal program at a lower rate. This can also allow bypassing the oscillator start-up time in cases where Power down mode would otherwise be used. The value of DIVM may be changed by the program at any time without interrupting code execution.

80C51 8-bit microcontroller with two-clock core
8 KB 3 V low-power Flash with 512-byte data EEPROM
P89LPC932**LOW POWER SELECT**

The LPC932 is designed to run at 12 MHz (CCLK) maximum. However, if CCLK is 8 MHz or slower, the CLKLP SFR bit (AUXR1.7) can be set to '1' to lower the power consumption further. On any reset, CLKLP is '0' allowing highest performance access. This bit can then be set in software if CCLK is running at 8 MHz or slower.

MEMORY ORGANIZATION

The various LPC932 memory spaces are as follows:

DATA	128 bytes of internal data memory space (00h..7Fh) accessed via direct or indirect addressing, using instructions other than MOVX and MOVC. All or part of the Stack may be in this area.
IDATA	Indirect Data. 256 bytes of internal data memory space (00h.FFh) accessed via indirect addressing using instructions other than MOVX and MOVC. All or part of the Stack may be in this area. This area includes the DATA area and the 128 bytes immediately above it.
SFR	Special Function Registers. Selected CPU registers and peripheral control and status registers, accessible only via direct addressing.
XDATA	"External" Data or Auxiliary RAM. Duplicates the classic 80C51 64 KB memory space addressed via the MOVX instruction using the DPTR, R0, or R1. All or part of this space could be implemented on-chip. The LPC932 has 512 bytes of on-chip XDATA memory.
CODE	64 KB of Code memory space, accessed as part of program execution and via the MOVC instruction. The LPC932 has 8 KB of on-chip Code memory.

The LPC932 also has 512 bytes of on-chip Data EEPROM that is accessed via SFRs (see section "Data EEPROM").

DATA RAM ARRANGEMENT

The 768 bytes of on-chip RAM organized as follows:

Table 1: On-Chip Data Memory Usages.

Type	Data RAM	Size (Bytes)
DATA	Memory that can be addressed directly and indirectly	128
IDATA	Memory that can be addressed indirectly	256
XDATA	Auxiliary ("External Data") on-chip memory that is accessed using the MOVX instructions	512

INTERRUPTS

The LPC932 uses a four priority level interrupt structure. This allows great flexibility in controlling the handling of the many interrupt sources. The LPC932 supports 15 interrupt sources: external interrupts 0 and 1, timers 0 and 1, serial port Tx, serial port Rx, combined serial port Rx/Tx, brownout detect, watchdog/ realtime clock, I²C, keyboard, comparators 1 and 2, SPI, CCU, data EEPROM write completion.

Each interrupt source can be individually enabled or disabled by setting or clearing a bit in the interrupt enable registers IEN0 or IEN1. The IEN0 register also contains a global disable bit, EA, which disables all interrupts.

Each interrupt source can be individually programmed to one of four priority levels by setting or clearing bits in the interrupt priority registers IPO, IPOH, IP1, and IP1H. An interrupt service routine in progress can be interrupted by a higher priority interrupt, but not by another interrupt of the same or lower priority. The highest priority interrupt service cannot be interrupted by any other interrupt source. If two requests of different priority levels are pending at the start of an instruction, the request of higher priority level is serviced.

If requests of the same priority level are pending at the start of an instruction, an internal polling sequence determines which request is serviced. This is called the arbitration ranking. Note that the arbitration ranking is only used to resolve pending requests of the same priority level.

80C51 8-bit microcontroller with two-clock core
8 KB 3 V low-power Flash with 512-byte data EEPROM

P89LPC932

External interrupt inputs

The LPC932 has two external interrupt inputs as well as the Keypad Interrupt function. The two interrupt inputs are identical to those present on the standard 80C51 microcontrollers.

These external interrupts can be programmed to be level-triggered or edge-triggered by setting or clearing bit IT1 or IT0 in Register TCON.

In edge-triggered mode if successive samples of the \overline{INTn} pin show a high in one cycle and a low in the next cycle, the interrupt request flag IEn in TCON is set, causing an interrupt request.

If an external interrupt is enabled when the LPC932 is put into Power down or Idle mode, the interrupt will cause the processor to wake up and resume operation. Refer to the section on Power Reduction Modes for details.

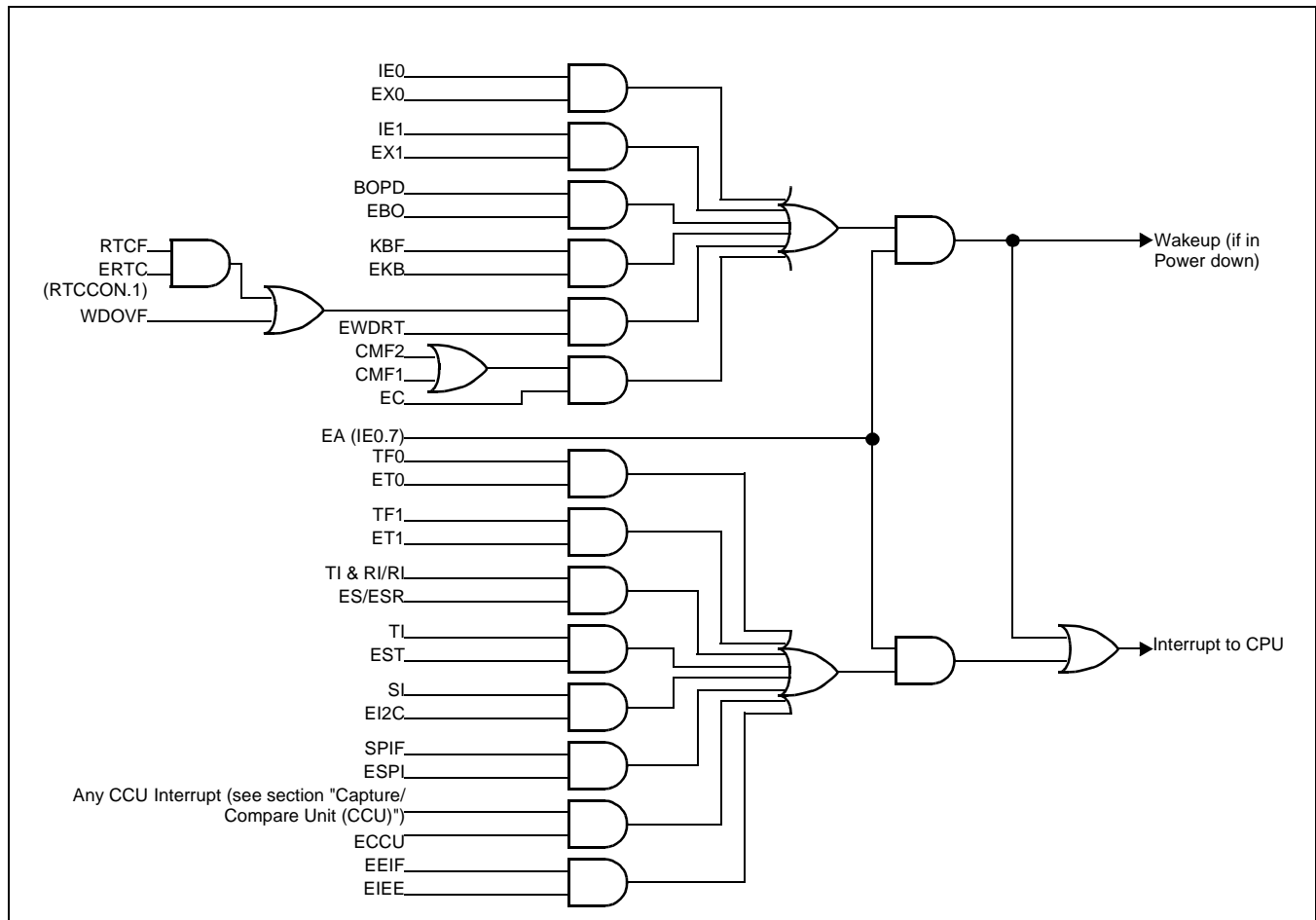

Figure 6: Interrupt sources, interrupt enables, and power-down wake-up sources

80C51 8-bit microcontroller with two-clock core**P89LPC932****8 KB 3 V low-power Flash with 512-byte data EEPROM****I/O PORTS**

The LPC932 has 4 I/O ports: Port 0, Port 1, Port2, and Port 3. Ports 0, 1 and 2 are 8-bit ports and Port 3 is a 2-bit port. The exact number of I/O pins available depend upon the clock and reset options chosen:

Table 2: Number of I/O pins available.

Clock source	Reset option	Number of I/O pins
		28-pin package
On-chip oscillator or watchdog oscillator	No external reset(except during power-up)	26
	External $\overline{\text{RST}}$ pin supported	25
External clock input	No external reset(except during power-up)	25
	External $\overline{\text{RST}}$ pin supported	24
Low/medium/high speed oscillator (external crystal or resonator)	No external reset(except during power-up)	24
	External $\overline{\text{RST}}$ pin supported	23

Port configurations

All but three I/O port pins on the LPC932 may be configured by software to one of four types on a bit-by-bit basis. These are: quasi-bidirectional (standard 80C51 port outputs), push-pull, open drain, and input-only. Two configuration registers for each port select the output type for each port pin.

P1.5 ($\overline{\text{RST}}$) can only be an input and cannot be configured.

P1.2 (SCL/T0) and P1.3 (SDA/ $\overline{\text{INT0}}$) may only be configured to be either input-only or open drain.

Quasi-bidirectional output configuration

Quasi-bidirectional output type can be used as both an input and output without the need to reconfigure the port. This is possible because when the port outputs a logic HIGH, it is weakly driven, allowing an external device to pull the pin LOW. When the pin is driven LOW, it is driven strongly and able to sink a fairly large current. These features are somewhat similar to an open drain output except that there are three pull-up transistors in the quasi-bidirectional output that serve different purposes.

LPC932 is a 3 V device, but the pins are 5 V-tolerant. In quasi-bidirectional mode, if a user applies 5 V on the pin, there will be a current flowing from the pin to V_{DD} , causing extra power consumption. Therefore, applying 5 V in quasi-bidirectional mode is discouraged.

A quasi-bidirectional port pin has a Schmitt-triggered input that also has a glitch suppression circuit.

Open drain output configuration

The open drain output configuration turns off all pullups and only drives the pulldown transistor of the port driver when the port latch contains a logic 0. To be used as a logic output, a port configured in this manner must have an external pull-up, typically a resistor tied to V_{DD} .

An open drain port pin has a Schmitt-triggered input that also has a glitch suppression circuit.

Input-only configuration

The input-only port configuration has no output drivers. It is a Schmitt-triggered input that also has a glitch suppression circuit.

Push-pull output configuration

The push-pull output configuration has the same pull-down structure as both the open drain and the quasi-bidirectional output modes, but provides a continuous strong pull-up when the port latch contains a logic 1. The push-pull mode may be used when more source current is needed from a port output. A push-pull port pin has a Schmitt-triggered input that also has a glitch suppression circuit.

80C51 8-bit microcontroller with two-clock core**P89LPC932****8 KB 3 V low-power Flash with 512-byte data EEPROM****Port 0 analog functions**

The LPC932 incorporates two Analog Comparators. In order to give the best analog function performance and to minimize power consumption, pins that are being used for analog functions must have the digital outputs and digital inputs disabled.

Digital outputs are disabled by putting the port output into the Input-Only (high impedance) mode as described in the I/O Ports section.

Digital inputs on Port 0 may be disabled through the use of the PT0AD register, bits 1:5. On any reset, PT0AD1:5 defaults to '0's to enable digital functions.

Additional Port Features

After power-up, all pins are in Input-Only mode. **Please note that this is different from the LPC76x series of devices.**

- After power-up, all I/O pins except P1.5, may be configured by software.
- Pin P1.5 is input only. Pins P1.2 and P1.3 and are configurable for either input-only or open drain.

Every output on the LPC932 has been designed to sink typical LED drive current. However, there is a maximum total output current for all ports which must not be exceeded. Please refer to the section DC Electrical Characteristics for detailed specifications.

All ports pins that can function as an output have slew rate controlled outputs to limit noise generated by quickly switching output signals. The slew rate is factory-set to approximately 10 ns rise and fall times.

POWER MONITORING FUNCTIONS

The LPC932 incorporates power monitoring functions designed to prevent incorrect operation during initial power-up and power loss or reduction during operation. This is accomplished with two hardware functions: Power-on Detect and Brownout detect.

Brownout detection

The Brownout detect function determines if the power supply voltage drops below a certain level. The default operation is for a Brownout detection to cause a processor reset, however it may alternatively be configured to generate an interrupt.

Brownout detection may be enabled or disabled in software.

If Brownout detection is enabled, the operating voltage range for V_{DD} is 2.7 V-3.6 V, and the brownout condition occurs when V_{DD} falls below the brownout trip voltage, V_{BO} (see DC Electrical Characteristics), and is negated when V_{DD} rises above V_{BO} . If brownout detection is disabled, the operating voltage range for V_{DD} is 2.4 V-3.6 V. If the LPC932 device is to operate with a power supply that can be below 2.7 V, BOE should be left in the unprogrammed state so that the device can operate at 2.4 V, otherwise continuous brownout reset may prevent the device from operating.

For correct activation of Brownout detect, the V_{DD} rise and fall times must be observed. Please see the DC Electrical Characteristics section of this datasheet for specifications.

Power-on Detection

The Power-on Detect has a function similar to the Brownout detect, but is designed to work as power comes up initially, before the power supply voltage reaches a level where Brownout detect can work. The POF flag in the RSTSRC register is set to indicate an initial power-up condition. The POF flag will remain set until cleared by software.

POWER REDUCTION MODES

The LPC932 supports three different power reduction modes. These modes are Idle mode, Power-down mode, and total Power-down mode.

Idle mode leaves peripherals running in order to allow them to activate the processor when an interrupt is generated. Any enabled interrupt source or reset may terminate Idle mode.

The Power-down mode stops the oscillator in order to minimize power consumption. The LPC932 exits Power-down mode via any reset, or certain interrupts. In Power-down mode, the power supply voltage may be reduced to the RAM keep-alive voltage V_{RAM} . This retains the RAM contents at the point where Power-down mode was entered. SFR contents are not guaranteed after V_{DD} has been lowered to V_{RAM} , therefore it is highly recommended to wake up the processor via reset in this case. V_{DD} must be raised to within the operating range before the Power-down mode is exited.

80C51 8-bit microcontroller with two-clock core**P89LPC932****8 KB 3 V low-power Flash with 512-byte data EEPROM**

Some chip functions continue to operate and draw power during Power-down mode, increasing the total power used during Power-down. These include: Brownout detect, Watchdog Timer, Comparators (Note: Comparators can be powered-down separately), and Real-Time Clock (RTC)/System Timer. The internal RC oscillator is disabled unless both the RC oscillator has been selected as the system clock AND the RTC is enabled.

Total Power down Mode: This is the same as Power down Mode except that the brownout detection circuitry and the voltage comparators are also disabled to conserve additional power. The internal RC oscillator is disabled unless both the RC oscillator has been selected as the system clock AND the RTC is enabled. If the internal RC oscillator is used to clock the RTC during Power down, there will be high power consumption. Please use an external low frequency clock to achieve low power with the Real-Time Clock running during Power down.

RESET

The P1.5/ $\overline{\text{RST}}$ pin can function as either an active-LOW reset input or as a digital input, P1.5. The RPE (Reset Pin Enable) bit in UCFG1, when set to 1, enables the external reset input function on P1.5. When cleared, P1.5 may be used as an input pin.

NOTE: During a power-up sequence, the RPE selection is overridden and this pin will always function as a reset input. **An external circuit connected to this pin should not hold this pin LOW during a power-on sequence as this will keep the device in reset.** After power-up this input will function either as an external reset input or as a digital input as defined by the RPE bit. Only a power-up reset will temporarily override the selection defined by RPE bit. Other sources of reset will not override the RPE bit.

Reset can be triggered from the following sources :

- External reset pin (during power-up or if user configured via UCFG1);
- Power-on detect;
- Brownout detect;
- Watchdog Timer;
- Software reset;
- UART break character detect reset.

For every reset source, there is a flag in the Reset Register, RSTSRC. The user can read this register to determine the most recent reset source. These flag bits can be cleared in software by writing a '0' to the corresponding bit. More than one flag bit may be set:

- During a power-on reset, both POF and BOF are set but the other flag bits are cleared.
- For any other reset, previously set flag bits that have not been cleared will remain set.

Reset vector

Following reset, the LPC932 will fetch instructions from either address 0000h or the Boot address. The Boot address is formed by using the Boot Vector as the high byte of the address and the low byte of the address =00h.

The Boot address will be used if a UART break reset occurs, or the non-volatile Boot Status bit (BOOTSTAT.0) = 1, or the device is forced into ISP mode during power-on (see User's Manual). Otherwise, instructions will be fetched from address 0000H.

TIMERS/COUNTERS 0 AND 1

The LPC932 has two general purpose counter/timers which are upward compatible with the standard 80C51 Timer 0 and Timer 1. Both can be configured to operate either as timers or event counter. An option to automatically toggle the T0 and/or T1 pins upon timer overflow has been added.

In the "Timer" function, the register is incremented every machine cycle.

In the "Counter" function, the register is incremented in response to a 1-to-0 transition at its corresponding external input pin, T0 or T1. In this function, the external input is sampled once during every machine cycle.

Timers 0 and Timer 1 have five operating modes (modes 0, 1, 2, 3 and 6). Modes 0, 1, 2 and 6 are the same for both Timers/Counters. Mode 3 is different.

80C51 8-bit microcontroller with two-clock core
8 KB 3 V low-power Flash with 512-byte data EEPROM

P89LPC932**Mode 0**

Putting either Timer into Mode 0 makes it look like an 8048 Timer, which is an 8-bit Counter with a divide-by-32 prescaler. In this mode, the Timer register is configured as a 13-bit register. Mode 0 operation is the same for Timer 0 and Timer 1.

Mode 1

Mode 1 is the same as Mode 0, except that all 16 bits of the timer register are used.

Mode 2

Mode 2 configures the Timer register as an 8-bit Counter with automatic reload. Mode 2 operation is the same for Timer 0 and Timer 1.

Mode 3

When Timer 1 is in Mode 3 it is stopped. Timer 0 in Mode 3 forms two separate 8-bit counters and is provided for applications that require an extra 8-bit timer. When Timer 1 is in Mode 3 it can still be used by the serial port as a baud rate generator.

Mode 6

In this mode, the corresponding timer can be changed to a PWM with a full period of 256 timer clocks.

Timer overflow toggle output

Timers 0 and 1 can be configured to automatically toggle a port output whenever a timer overflow occurs. The same device pins that are used for the T0 and T1 count inputs are also used for the timer toggle outputs. The port outputs will be a logic 1 prior to the first timer overflow when this mode is turned on.

REAL-TIME CLOCK/SYSTEM TIMER

The LPC932 has a simple Real-Time clock that allows a user to continue running an accurate timer while the rest of the device is powered down. The Real-Time clock can be a wake-up or an interrupt source. The Real-Time clock is a 23-bit down counter comprised of a 7-bit prescaler and a 16-bit loadable down counter. When it reaches all 0's, the counter will be reloaded again and the RTCF flag will be set. The clock source for this counter can be either the CPU clock (CCLK) or the XTAL oscillator, provided that the XTAL oscillator is not being used as the CPU clock. If the XTAL oscillator is used as the CPU clock, then the RTC will use CCLK as its clock source. Only power-on reset will reset the Real-Time Clock and its associated SFRs to the default state.

CAPTURE/COMPARE UNIT (CCU)

This unit features:

- A 16-bit timer with 16-bit reload on overflow
- Selectable clock, with prescaler to divide clock source by any integral number between 1 and 1024.
- 4 Compare / PWM outputs with selectable polarity
- Symmetrical / Asymmetrical PWM selection
- 2 Capture inputs with event counter and digital noise rejection filter
- 7 interrupts with common interrupt vector (one Overflow, 2XCapture, 4XCompare),
- Safe 16-bit read/write via shadow registers

CCU clock (CCUCLK)

The CCU runs on the CCUCLK, which is either PCLK in basic timer mode, or the output of a PLL. The PLL is designed to use a clock source between 0.5 MHz to 1 MHz that is multiplied by 32 to produce a CCUCLK between 16 MHz and 32 MHz in PWM mode (asymmetrical or symmetrical). The PLL contains a 4-bit divider to help divide PCLK into a frequency between 0.5 MHz and 1 MHz.

CCU clock prescaling

This CCUCLK can further be divided down by a prescaler. The prescaler is implemented as a 10-bit free-running counter with programmable reload at overflow.

Basic timer operation

The Timer is a free-running up/down counter with a direction control bit. If the timer counting direction is changed while the counter is running, the count sequence will be reversed. The timer can be written or read at any time.

When a reload occurs, the CCU Timer Overflow Interrupt Flag will be set, and an interrupt generated if enabled. The 16-bit CCU Timer may also be used as an 8-bit up/down timer.

Output compare

There are four output compare channels A, B, C and D. Each output compare channel needs to be enabled in order to operate and the user will have to set the associated I/O pin to the desired output mode to connect the pin. When the contents of the timer matches that of a capture compare control register, the Timer Output Compare Interrupt Flag - TOCFx becomes set. An interrupt will occur if enabled.

Input capture

Input capture is always enabled. Each time a capture event occurs on one of the two input capture pins, the contents of the timer is transferred to the corresponding 16-bit input capture register. The capture event can be programmed to be either rising or falling edge triggered. A simple noise filter can be enabled on the input capture by enabling the Input Capture Noise Filter bit. If set, the capture logic needs to see four consecutive samples of the same value in order to recognize an edge as a capture event. An event counter can be set to delay a capture by a number of capture events.

PWM operation

PWM operation has two main modes, symmetrical and asymmetrical.

In asymmetrical PWM operation the CCU Timer operates in downcounting mode regardless of the direction control bit.

In symmetrical mode, the timer counts up/down alternately. The main difference from basic timer operation is the operation of the compare module, which in PWM mode is used for PWM waveform generation.

As with basic timer operation, when the PWM (compare) pins are connected to the compare logic, their logic state remains unchanged. However, since bit FCO is used to hold the halt value, only a compare event can change the state of the pin.

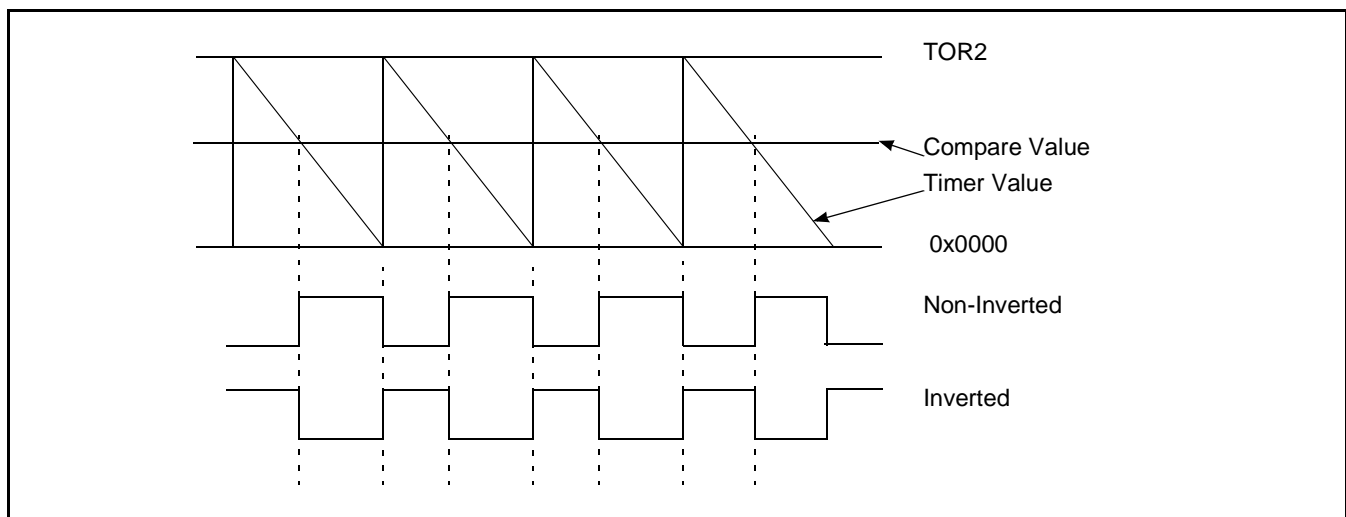

Figure 7: Asymmetrical PWM, downcounting

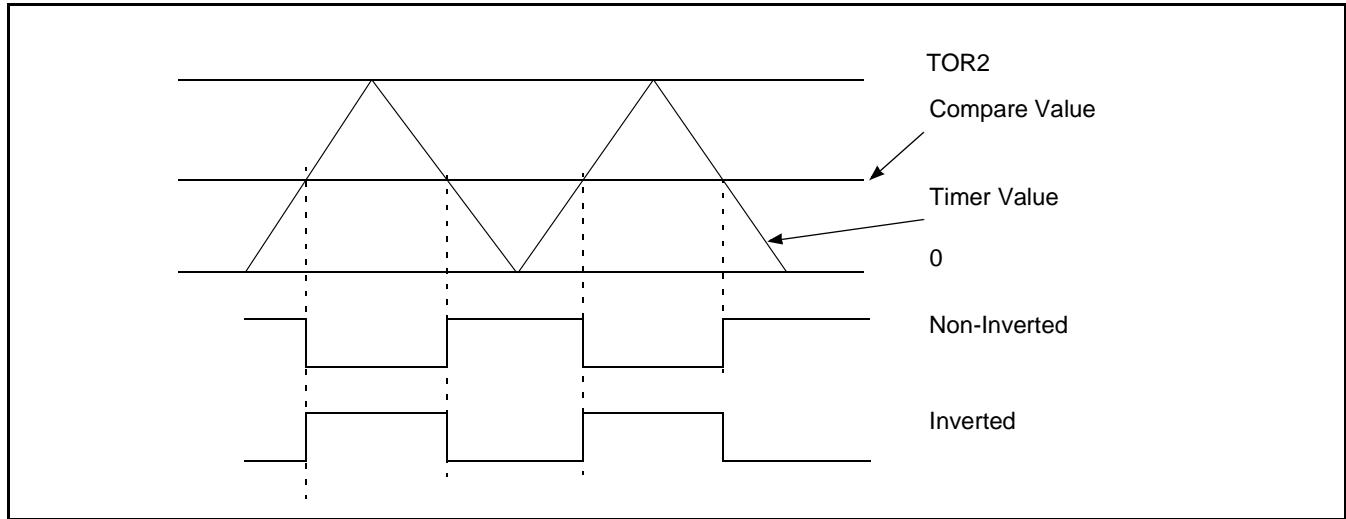

Figure 8: Symmetrical PWM

Alternating Output Mode

In asymmetrical mode, the user can set up PWM channels A/B and C/D as alternating pairs for bridge drive control. In this mode the output of these PWM channels are alternately gated on every counter cycle.

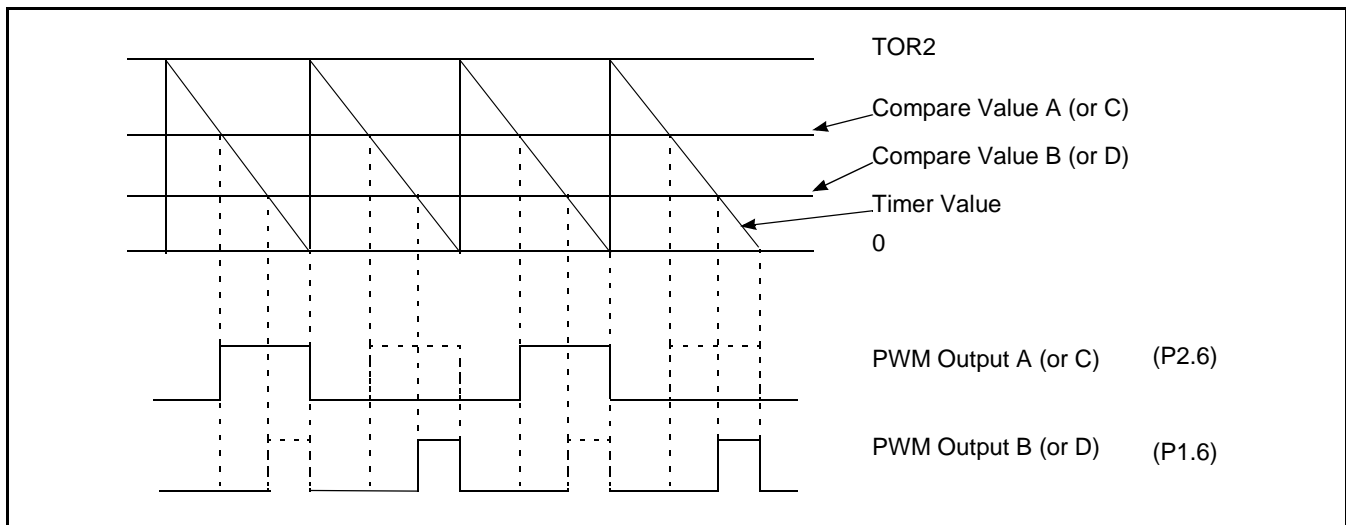

Figure 9: Alternate output mode

PLL operation

The PWM module features a Phase Locked Loop that can be used to generate a CCUCLK frequency between 16 MHz and 32 MHz. At this frequency the PWM module provides ultrasonic PWM frequency with 10-bit resolution provided that the crystal frequency is 1 MHz or higher. The PLL is fed an input signal of 0.5 - 1 MHz and generates an output signal of 32 times the input frequency. This signal is used to clock the timer. The user will have to set a divider that scales PCLK by a factor of 1-16. This divider is found in the SFR register TCR21. The PLL frequency can be expressed as follows:

$$\text{PLL frequency} = \text{PCLK} / (\text{N}+1)$$

Where: N is the value of PLLDV3:0.

Since N ranges in 0 - 15, the CCLK frequency can be in the range of PCLK to PCLK/16.

CCU interrupts

There are seven interrupt sources on the CCU which share a common interrupt vector.

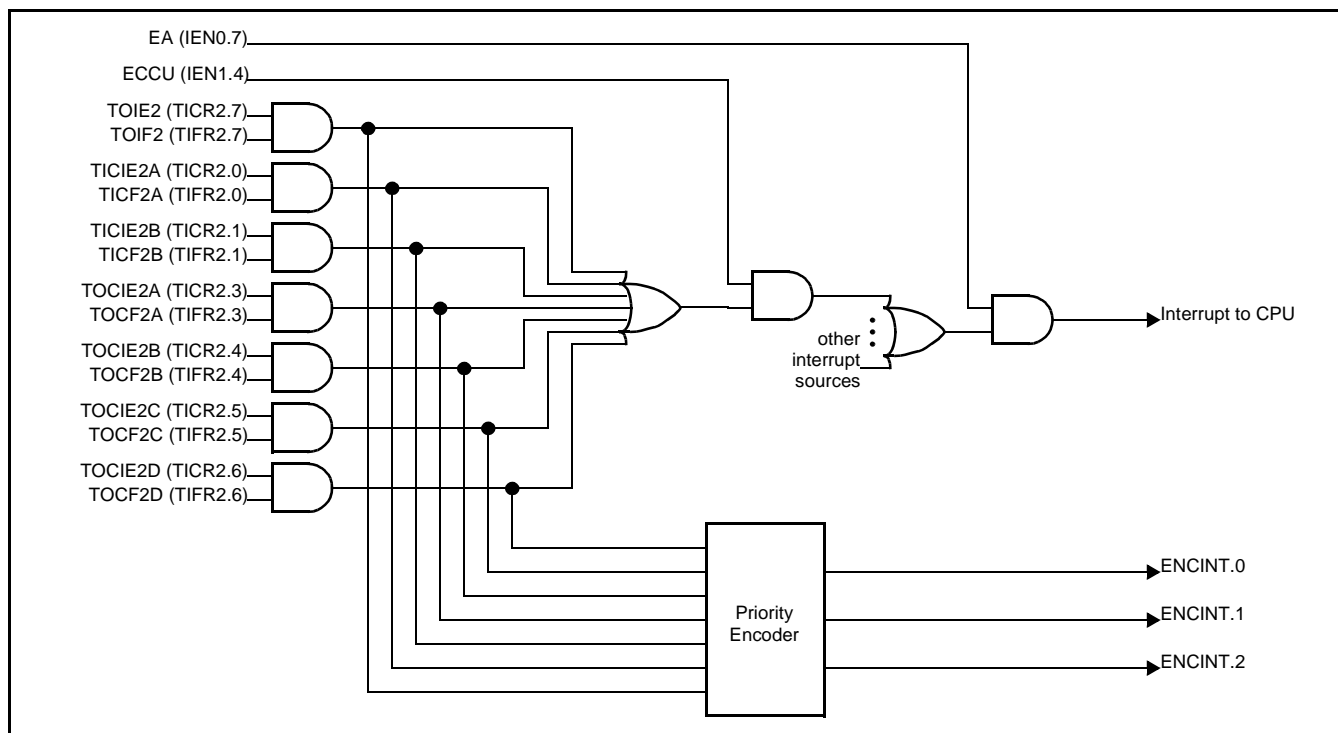

Figure 10: Capture/Compare Unit interrupts

UART

The LPC932 has an enhanced UART that is compatible with the conventional 80C51 UART except that Timer 2 overflow cannot be used as a baud rate source. The LPC932 does include an independent Baud Rate Generator. The baud rate can be selected from the oscillator (divided by a constant), Timer 1 overflow, or the independent Baud Rate Generator. In addition to the baud rate generation, enhancements over the standard 80C51 UART include Framing Error detection, automatic address recognition, selectable double buffering and several interrupt options. The UART can be operated in 4 modes: shift register, 8-bit UART, 9-bit UART, and CPU clock/32 or CPU clock/16

Mode 0

Serial data enters and exits through RxD. TxD outputs the shift clock. 8 bits are transmitted or received, LSB first. The baud rate is fixed at 1/16 of the CPU clock frequency.

Mode 1

10 bits are transmitted (through TxD) or received (through RxD): a start bit (logical 0), 8 data bits (LSB first), and a stop bit (logical 1). When data is received, the stop bit is stored in RB8 in Special Function Register SCON. The baud rate is variable and is determined by the Timer 1 overflow rate or the Baud Rate Generator (described later in section on "Baud rate generator and selection").

Mode 2

11 bits are transmitted (through TxD) or received (through RxD): start bit (logical 0), 8 data bits (LSB first), a programmable 9th data bit, and a stop bit (logical 1). When data is transmitted, the 9th data bit (TB8 in SCON) can be assigned the value of 0 or 1. Or, for example, the parity bit (P, in the PSW) could be moved into TB8. When data is received, the 9th data bit goes into RB8 in Special Function Register SCON, while the stop bit is not saved. The baud rate is programmable to either 1/16 or 1/32 of the CPU clock frequency, as determined by the SMOD1 bit in PCON.

80C51 8-bit microcontroller with two-clock core**P89LPC932****8 KB 3 V low-power Flash with 512-byte data EEPROM****Mode 3**

11 bits are transmitted (through TxD) or received (through RxD): a start bit (logical 0), 8 data bits (LSB first), a programmable 9th data bit, and a stop bit (logical 1). In fact, Mode 3 is the same as Mode 2 in all respects except baud rate. The baud rate in Mode 3 is variable and is determined by the Timer 1 overflow rate or the Baud Rate Generator (described later in section on "Baud rate generator and selection").

Baud rate generator and selection

The LPC932 enhanced UART has an independent Baud Rate Generator. The baud rate is determined by a baud-rate preprogrammed into the BRGR1 and BRGR0 SFRs which together form a 16-bit baud rate divisor value that works in a similar manner as Timer 1. If the baud rate generator is used, Timer 1 can be used for other timing functions.

The UART can use either Timer 1 or the baud rate generator output (see Figure 11). Note that Timer T1 is further divided by 2 if the SMOD1 bit (PCON.7) is set. The independent Baud Rate Generator uses OSCCLK.

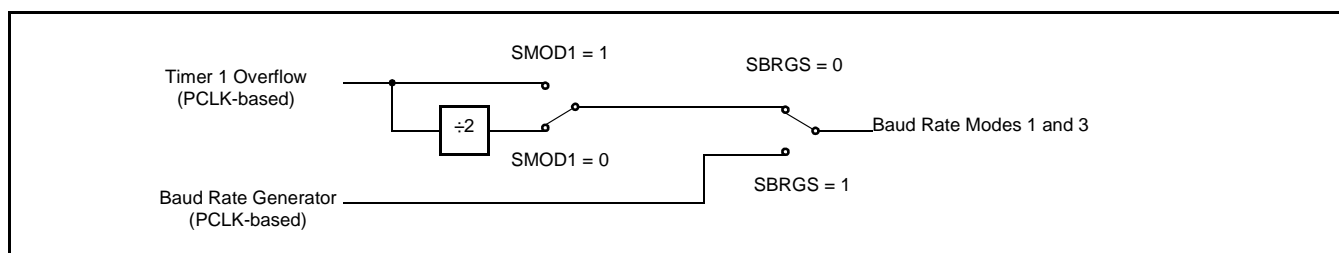

Figure 11: Baud rate sources for UART (Modes 1, 3)

Framing error

Framing error is reported in the status register (SSTAT). In addition, if SMOD0 (PCON.6) is 1, framing errors can be made available in SCON.7 respectively. If SMOD0 is 0, SCON.7 is SM0. It is recommended that SM0 and SM1 (SCON.7-6) are set up when SMOD0 is '0'.

Break detect

Break detect is reported in the status register (SSTAT). A break is detected when 11 consecutive bits are sensed low. The break detect can be used to reset the device and force the device into ISP mode.

Double buffering

The UART has a transmit double buffer that allows buffering of the next character to be written to SBUF while the first character is being transmitted. Double buffering allows transmission of a string of characters with only one stop bit between any two characters, as long as the next character is written between the start bit and the stop bit of the previous character.

Double buffering can be disabled. If disabled (DBMOD, i.e. SSTAT.7 = 0), the UART is compatible with the conventional 80C51 UART. If enabled, the UART allows writing to SnBUF while the previous data is being shifted out. Double buffering is only allowed in Modes 1, 2 and 3. When operated in Mode 0, double buffering must be disabled (DBMOD = 0).

Transmit interrupts with double buffering enabled (Modes 1, 2 and 3)

Unlike the conventional UART, in double buffering mode, the Tx interrupt is generated when the double buffer is ready to receive new data.

The 9th bit (Bit 8) in double buffering (Modes 1, 2 and 3)

If double buffering is disabled TB8 can be written before or after SBUF is written, as long as TB8 is updated some time before that bit is shifted out. TB8 must not be changed until the bit is shifted out, as indicated by the Tx interrupt.

If double buffering is enabled, TB8 MUST be updated before SBUF is written, as TB8 will be double-buffered together with SBUF data.

I²C SERIAL INTERFACE

I²C-bus uses two wires (SDA and SCL) to transfer information between devices connected to the bus, and it has the following features:

- Bi-directional data transfer between masters and slaves
- Multimaster bus (no central master)
- Arbitration between simultaneously transmitting masters without corruption of serial data on the bus
- Serial clock synchronization allows devices with different bit rates to communicate via one serial bus
- Serial clock synchronization can be used as a handshake mechanism to suspend and resume serial transfer
- The I²C-bus may be used for test and diagnostic purposes

A typical I²C-bus configuration is shown in Figure 12. The LPC932 device provides a byte-oriented I²C interface that supports data transfers up to 400 kHz.

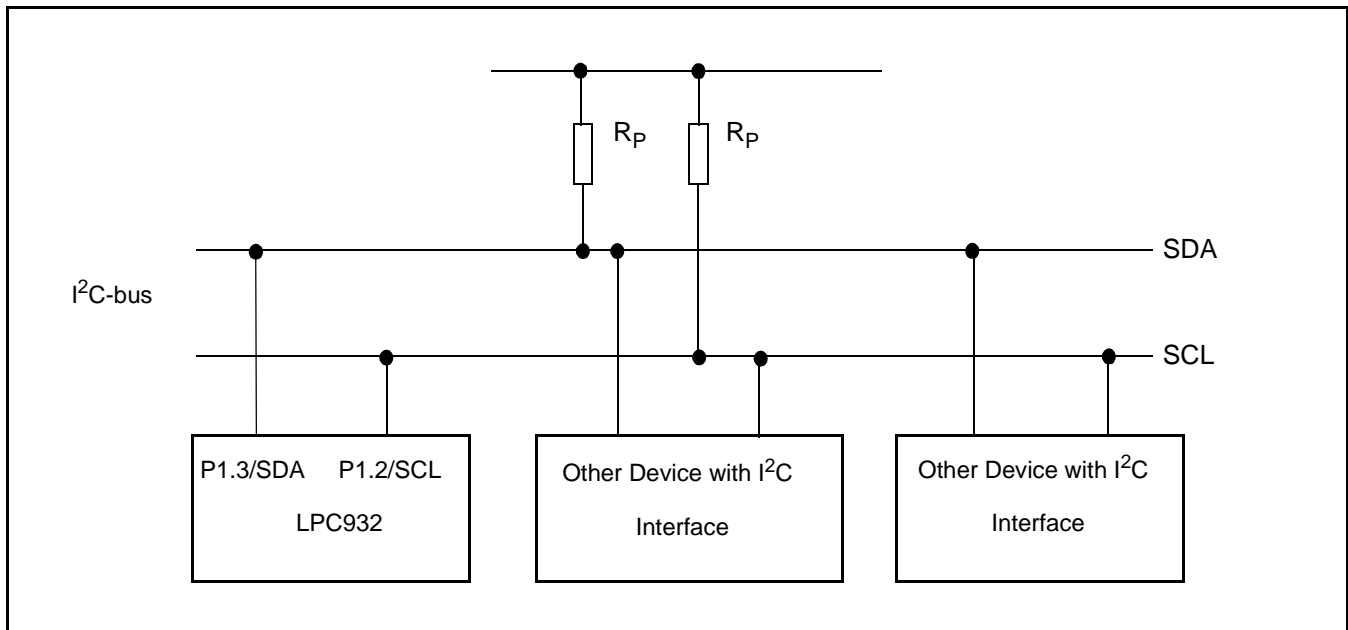

Figure 12: I²C-bus configuration

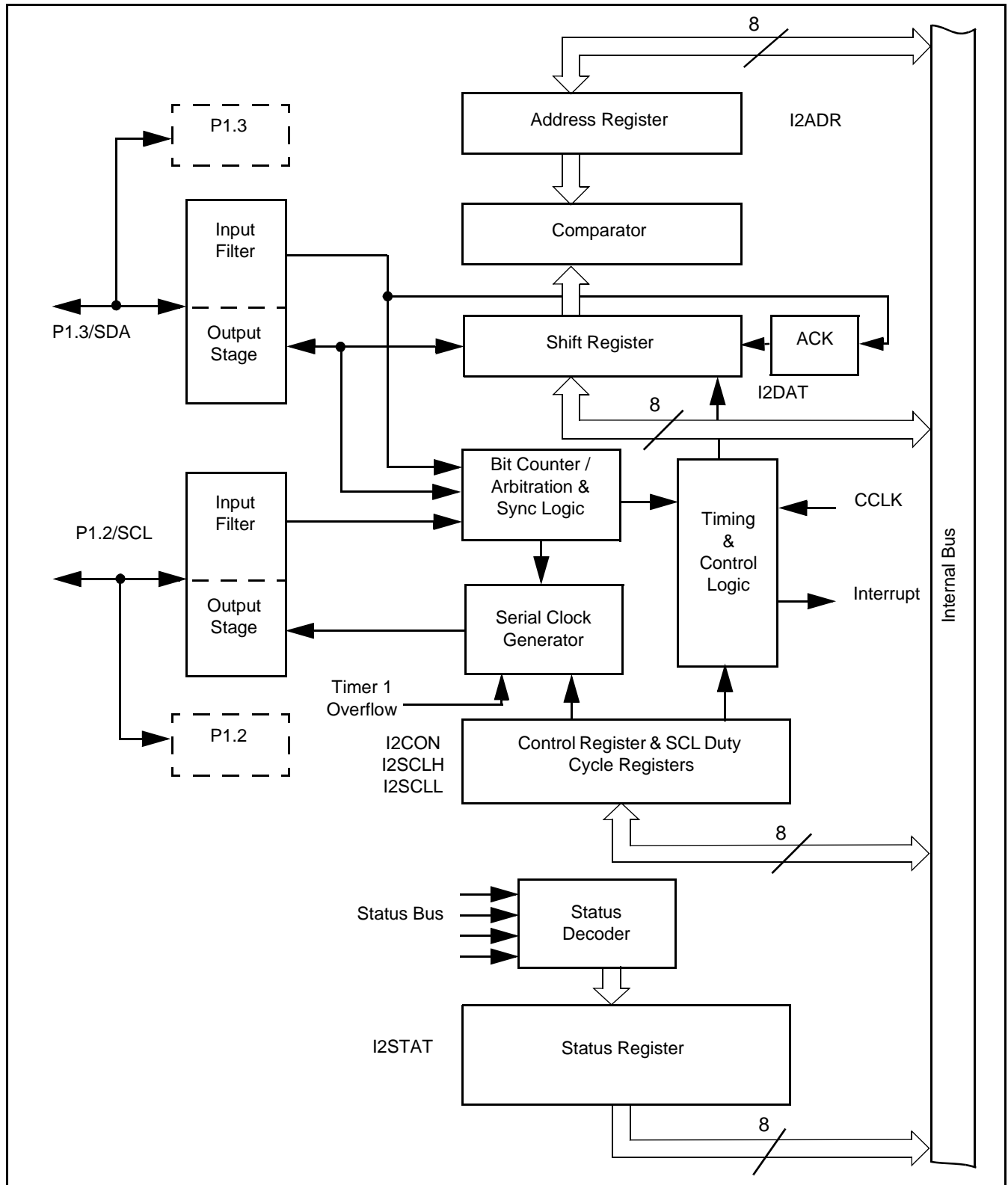

Figure 13: I²C-bus serial interface block diagram

SERIAL PERIPHERAL INTERFACE (SPI)

LPC932 provides another high-speed serial communication interface - the SPI interface. SPI is a full-duplex, high-speed, synchronous communication bus with two operation mode: Master mode and Slave mode. Up to 3 Mbit/s can be supported in either Master or Slave mode. It has a Transfer Completion Flag and Write Collision Flag Protection.

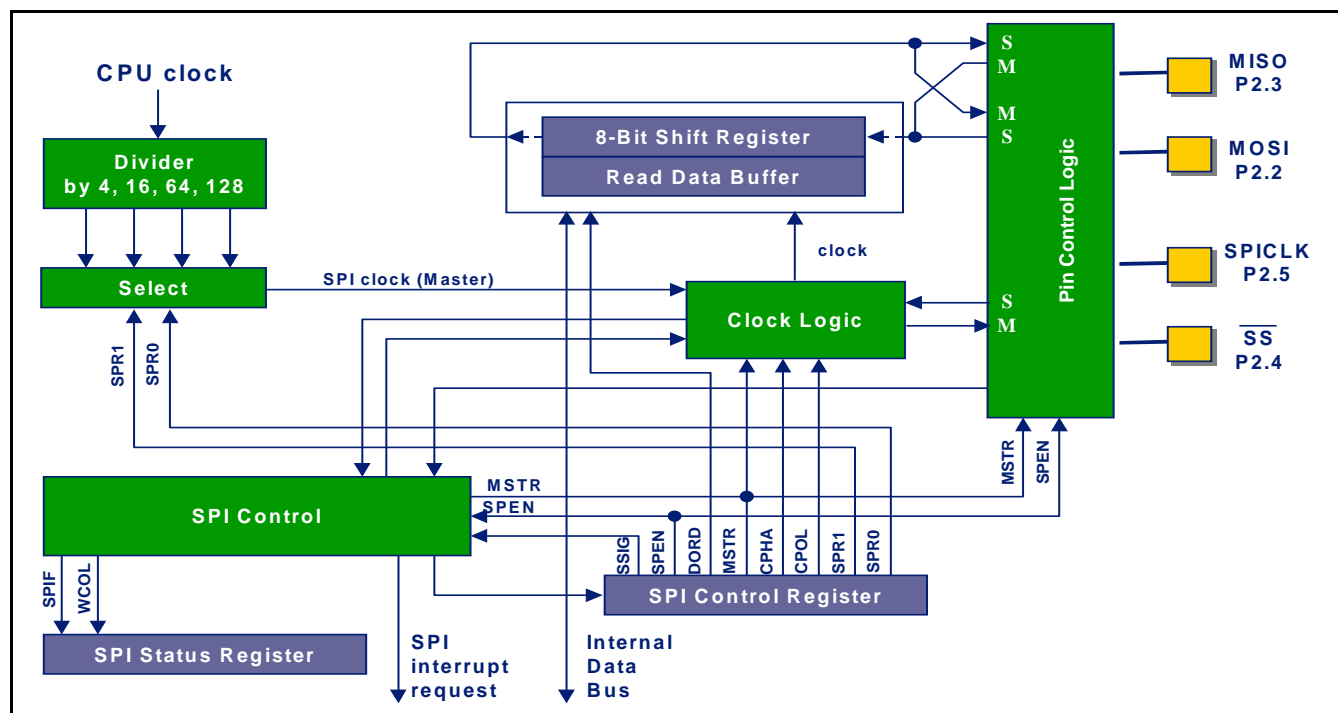

Figure 14: SPI block diagram

The SPI interface has four pins: SPICLK, MOSI, MISO and \overline{SS} :

- SPICLK, MOSI and MISO are typically tied together between two or more SPI devices. Data flows from master to slave on MOSI (Master Out Slave In) pin and flows from slave to master on MISO (Master In Slave Out) pin. The SPICLK signal is output in the master mode and is input in the slave mode. If the SPI system is disabled, i.e. SPEN (SPCTL.6) = 0 (reset value), these pins are configured for port functions.
- \overline{SS} is the optional slave select pin. In a typical configuration, an SPI master asserts one of its port pins to select one SPI device as the current slave. An SPI slave device uses its \overline{SS} pin to determine whether it is selected.

Typical connections are shown in Figures 15 - 17.

Typical SPI configurations

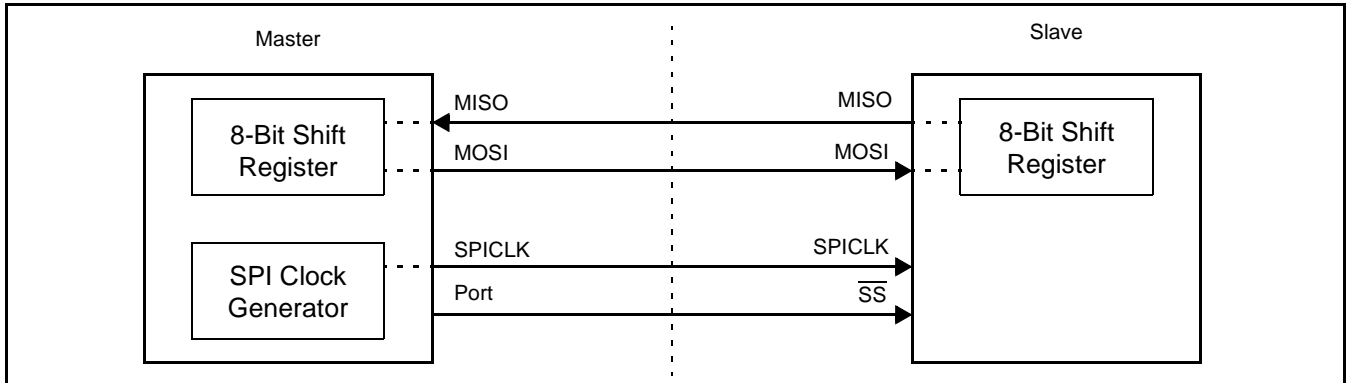

Figure 15: SPI single master single slave configuration

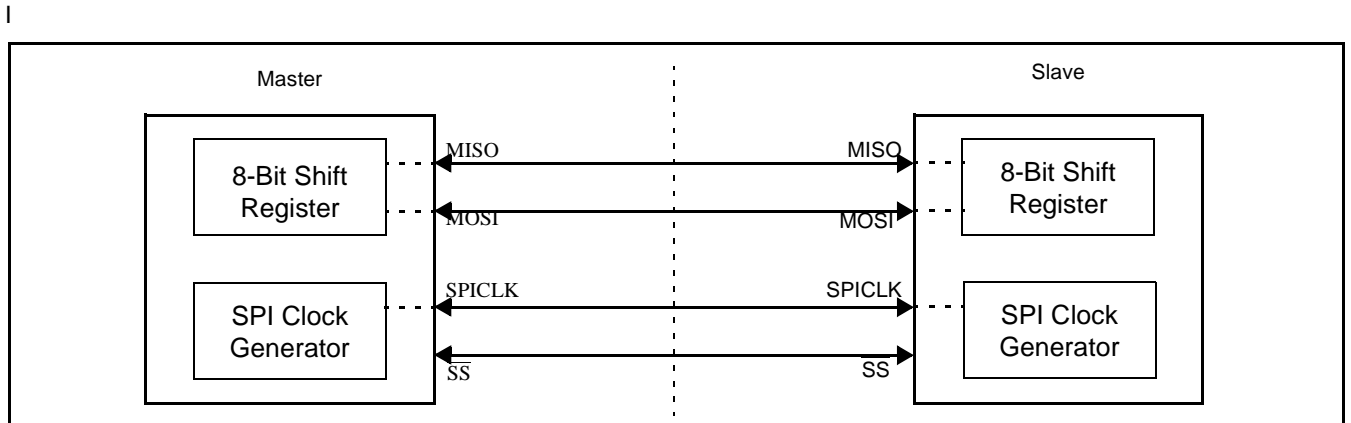

Figure 16: SPI dual device configuration, where either can be a master or a slave.

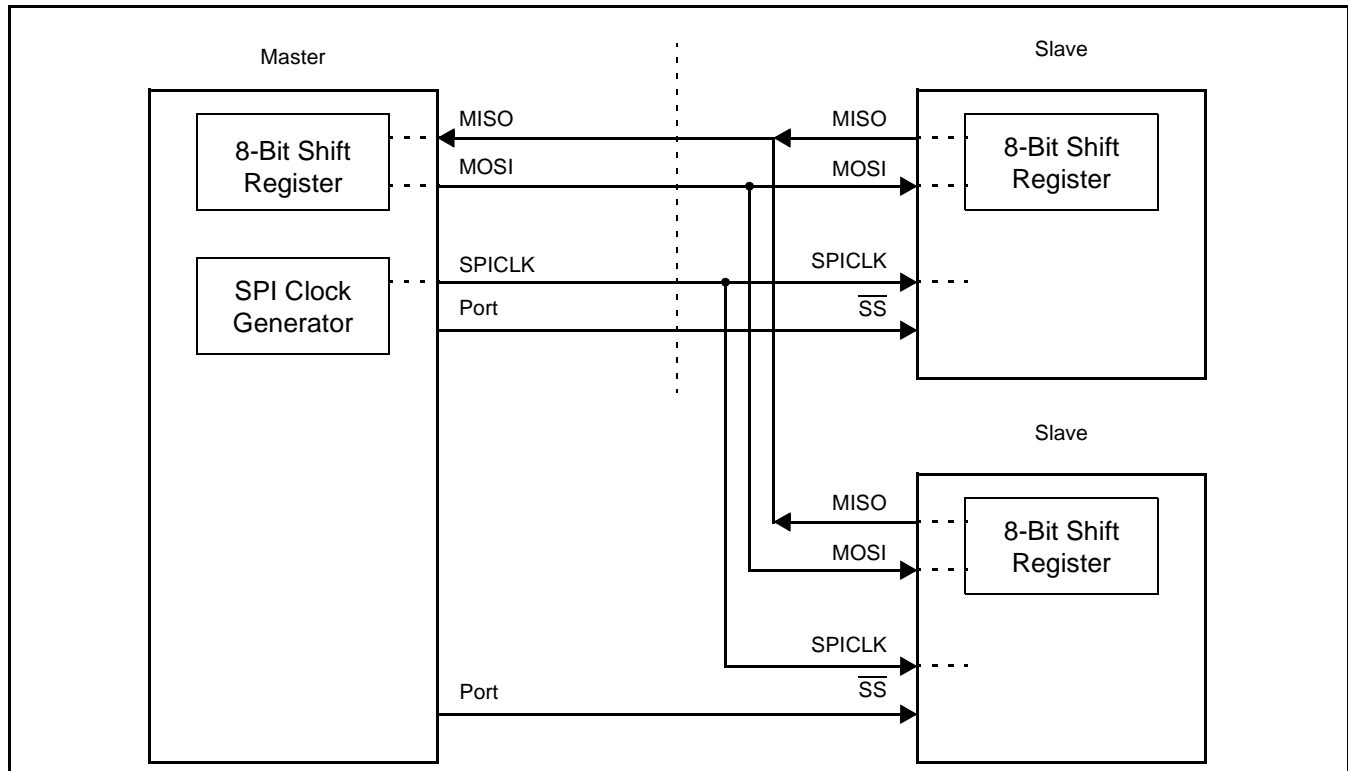

Figure 17: SPI single master multiple slaves configuration

ANALOG COMPARATORS

Two analog comparators are provided on the LPC932. Input and output options allow use of the comparators in a number of different configurations. Comparator operation is such that the output is a logical one (which may be read in a register and/or routed to a pin) when the positive input (one of two selectable pins) is greater than the negative input (selectable from a pin or an internal reference voltage). Otherwise the output is a zero. Each comparator may be configured to cause an interrupt when the output value changes.

The overall connections to both comparators are shown in Figure 18. The comparators function to $V_{DD} = 2.4\text{ V}$.

When each comparator is first enabled, the comparator output and interrupt flag are not guaranteed to be stable for 10 microseconds. The corresponding comparator interrupt should not be enabled during that time, and the comparator interrupt flag must be cleared before the interrupt is enabled in order to prevent an immediate interrupt service.

Internal reference voltage

An internal reference voltage generator may supply a default reference when a single comparator input pin is used. The value of the internal reference voltage, referred to as V_{ref} , is $1.23\text{ V} \pm 10\%$.

Comparator interrupt

Each comparator has an interrupt flag contained in its configuration register. This flag is set whenever the comparator output changes state. The flag may be polled by software or may be used to generate an interrupt. The two comparators use one common interrupt vector. If both comparators enable interrupts, after entering the interrupt service routine, the user needs to read the flags to determine which comparator caused the interrupt.

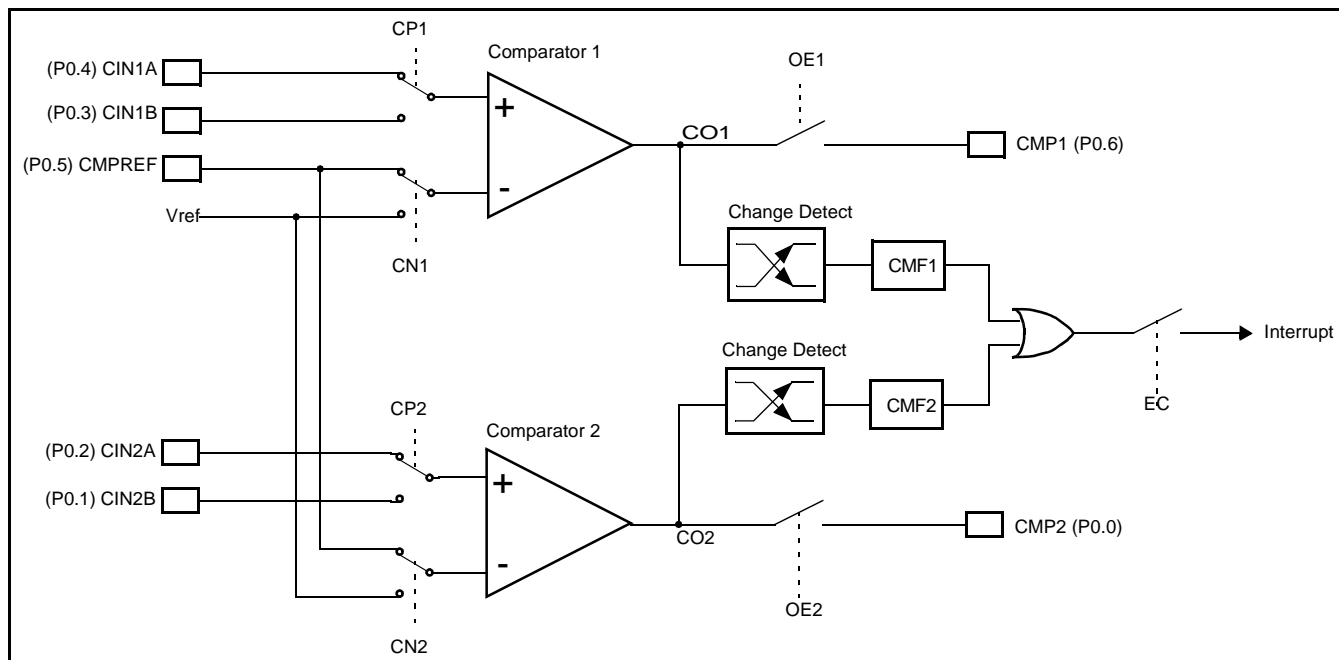

Figure 18: Comparator input and output connections

Comparators and Power Reduction Modes

Either or both comparators may remain enabled when Power-down or Idle mode is activated, but both comparators are disabled automatically in Total Power-down mode.

If a comparator interrupt is enabled (except in Total Power-down mode), a change of the comparator output state will generate an interrupt and wake up the processor. If the comparator output to a pin is enabled, the pin should be configured in the push-pull mode in order to obtain fast switching times while in power-down mode. The reason is that with the oscillator stopped, the temporary strong pull-up that normally occurs during switching on a quasi-bidirectional port pin does not take place.

Comparators consume power in Power-down and Idle modes, as well as in the normal operating mode. This fact should be taken into account when system power consumption is an issue. To minimize power consumption, the user can disable the comparators via PCONA.5, or put the device in Total Power-down mode.

KEYPAD INTERRUPT (KBI)

The Keypad Interrupt function is intended primarily to allow a single interrupt to be generated when Port 0 is equal to or not equal to a certain pattern. This function can be used for bus address recognition or keypad recognition. The user can configure the port via SFRs for different tasks.

The Keypad Interrupt Mask Register (KBMASK) is used to define which input pins connected to Port 0 can trigger the interrupt. The Keypad Pattern Register (KBPATN) is used to define a pattern that is compared to the value of Port 0. The Keypad Interrupt Flag (KBIF) in the Keypad Interrupt Control Register (KBCON) is set when the condition is matched while the Keypad Interrupt function is active. An interrupt will be generated if enabled. The PATN_SEL bit in the Keypad Interrupt Control Register (KBCON) is used to define equal or not-equal for the comparison.

In order to use the Keypad Interrupt as an original KBI function like in 87LPC76x series, the user needs to set KBPATN = 0FFH and PATN_SEL = 1 (not equal), then any key connected to Port 0 which is enabled by the KBMASK register will cause the hardware to set KBIF and generate an interrupt if it has been enabled. The interrupt may be used to wake up the CPU from Idle or Power-down modes. This feature is particularly useful in handheld, battery-powered systems that need to carefully manage power consumption yet also need to be convenient to use.

In order to set the flag and cause an interrupt, the pattern on Port 0 must be held longer than 6 CCLKs.

WATCHDOG TIMER

The watchdog timer causes a system reset when it underflows as a result of a failure to feed the timer prior to the timer reaching its terminal count. It consists of a programmable 12-bit prescaler, and an 8-bit down counter. The down counter is decremented by a tap taken from the prescaler. The clock source for the prescaler is either the PCLK or the nominal 40 kHz watchdog oscillator. The watchdog timer can only be reset by a power-on reset. When the watchdog feature is disabled, it can be used as an interval timer and may generate an interrupt. Figure 19 shows the watchdog timer in watchdog mode. Feeding the watchdog requires a two-byte sequence. If PCLK is selected as the watchdog clock and the CPU is powered down, the watchdog is disabled. The watchdog timer has a timeout period that ranges from a few μ s to a few seconds. Please refer to the User's Manual for more details.

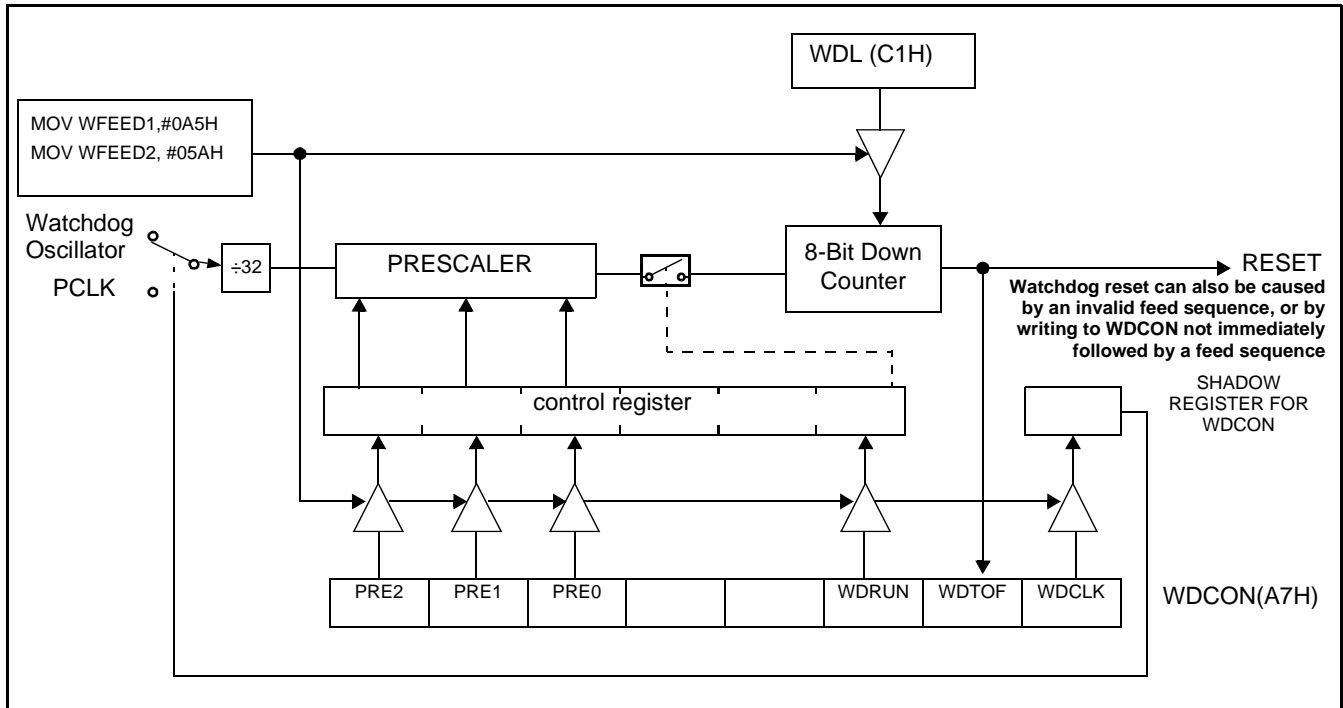

Figure 19: Watchdog timer in Watchdog mode (WDTE = 1)

80C51 8-bit microcontroller with two-clock core
8 KB 3 V low-power Flash with 512-byte data EEPROM

P89LPC932

ADDITIONAL FEATURES

Software Reset

The SRST bit in AUXR1 gives software the opportunity to reset the processor completely, as if an external reset or watchdog reset had occurred. Care should be taken when writing to AUXR1 to avoid accidental software resets.

Dual Data Pointers

The dual Data Pointers (DPTR) provides two different Data Pointers to specify the address used with certain instructions. The DPS bit in the AUXR1 register selects one of the two Data Pointers. Bit 2 of AUXR1 is permanently wired as a logic 0 so that the DPS bit may be toggled (thereby switching Data Pointers) simply by incrementing the AUXR1 register, without the possibility of inadvertently altering other bits in the register.

DATA EEPROM

The LPC932 has 512 bytes of on-chip Data EEPROM. The Data EEPROM is SFR based, byte readable, byte writable, and erasable (via row fill and sector fill). The user can read, write and fill the memory via SFRs and one interrupt. This Data EEPROM provides 100,000 minimum erase/program cycles for each byte.

Byte Mode: In this mode, data can be read and written one byte at a time.

Row Fill: In this mode, the addressed row (64 bytes) is filled with a single value. The entire row can be erased by writing 00h.

Sector Fill: In this mode, all 512 bytes are filled with a single value. The entire sector can be erased by writing 00h.

After the operation finishes, the hardware will set the EEIF bit, which if enabled will generate an interrupt. The flag is cleared by software.

FLASH PROGRAM MEMORY

General description

The LPC932 Flash memory provides in-circuit electrical erasure and programming. The Flash can be read and written as bytes. The Sector and Page Erase functions can erase any Flash sector (1 KB) or page (64 bytes). The Chip Erase operation will erase the entire program memory. In-System Programming and standard parallel programming are both available. On-chip erase and write timing generation contribute to a user-friendly programming interface. The LPC932 Flash reliably stores memory contents even after 10,000 erase and program cycles. The cell is designed to optimize the erase and programming mechanisms. The LPC932 uses V_{DD} as the supply voltage to perform the Program/Erase algorithms.

Features

- Internal fixed boot ROM, containing low-level In-Application Programming (IAP) routines
- User programs can call these routines to perform In-Application Programming (IAP).
- Default loader providing In-System Programming via the serial port, located in upper end of user program memory.
- Boot vector allows user provided Flash loader code to reside anywhere in the Flash memory space, providing flexibility to the user.
- Programming and erase over the full operating voltage range
- Read/Programming/Erase using ISP/IAP
- Any flash program/erase operation in 2 ms
- Parallel programming with industry-standard commercial programmers
- Programmable security for the code in the Flash for each sector.
- 10,000 minimum erase/program cycles for each byte.
- 10-year minimum data retention.

80C51 8-bit microcontroller with two-clock core**P89LPC932****8 KB 3 V low-power Flash with 512-byte data EEPROM****ISP and IAP capabilities of the LPC932****Flash organization**

The LPC932 program memory consists of eight 1 KB sectors. Each sector can be further divided into 64-byte pages. In addition to sector erase and page erase, a 64-byte page register is included which allows from 1 to 64 bytes of a given page to be programmed at the same time, substantially reducing overall programming time. An In-Application Programming (IAP) interface is provided to allow the end user's application to erase and reprogram the user code memory. In addition, erasing and reprogramming of user-programmable bytes including UCFG1, the Boot Status Bit, and the Boot Vector is supported. As shipped from the factory, the upper 512 bytes of user code space contains a serial In-System Programming (ISP) routine allowing for the device to be programmed in circuit through the serial port.

Flash programming and erasing

There are three methods of erasing or programming of the Flash memory that may be used. First, the Flash may be programmed or erased in the end-user application by calling low-level routines through a common entry point. Second, the on-chip ISP boot loader may be invoked. This ISP boot loader will, in turn, call low-level routines through the same common entry point that can be used by the end-user application. Third, the Flash may be programmed or erased using the parallel method by using a commercially available EPROM programmer which supports this device. This device does not provide for direct verification of code memory contents. Instead this device provides a 32-bit CRC result on either a sector or the entire 8 KB of user code space.

Boot ROM

When the microcontroller programs its own Flash memory, all of the low level details are handled by code that is contained in a Boot ROM that is separate from the Flash memory. A user program simply calls the common entry point in the Boot ROM with appropriate parameters to accomplish the desired operation. The Boot ROM include operations such as erase sector, erase page, program page, CRC, program security bit, etc. The Boot ROM occupies the program memory space at the top of the address space from FF00 to FFFF hex, thereby not conflicting with the user program memory space.

Power-on Reset code execution

The LPC932 contains two special Flash elements: the Boot Vector and the Boot Status Bit. Following reset, the LPC932 examines the contents of the Boot Status Bit. If the Boot Status Bit is set to zero, power-up execution starts at location 0000H, which is the normal start address of the user's application code. When the Boot Status Bit is set to a value other than zero, the contents of the Boot Vector is used as the high byte of the execution address and the low byte is set to 00H. The factory default setting is 01EH, corresponds to the address 1E00H for the default ISP boot loader. This boot loader is pre-programmed at the factory into this address space and can be erased by the user. **Users who wish to use this loader should take cautions to avoid erasing the 1KB sector from 1C00H to 1FFFH. Instead, the page erase function can be used to erase the eight 64-byte pages located from 1C00H to 1DFFFH.** A custom boot loader can be written with the Boot Vector set to the custom boot loader, if desired.

Hardware activation of the Boot Loader

The boot loader can also be executed by forcing the device into ISP mode during a power-on sequence (see *User's Manual* for specific information). This has the same effect as having a non-zero status byte. This allows an application to be built that will normally execute user code but can be manually forced into ISP operation. If the factory default setting for the Boot Vector (1EH) is changed, it will no longer point to the factory pre-programmed ISP boot loader code. If this happens, the only way it is possible to change the contents of the Boot Vector is through the parallel programming method, provided that the end user application does not contain a customized loader that provides for erasing and reprogramming of the Boot Vector and Boot Status Bit. After programming the Flash, the status byte should be programmed to zero in order to allow execution of the user's application code beginning at address 0000H.

In-System Programming (ISP)

In-System Programming is performed without removing the microcontroller from the system. The In-System Programming facility consists of a series of internal hardware resources coupled with internal firmware to facilitate remote programming of the LPC932 through the serial port. This firmware is provided by Philips and embedded within each LPC932 device. The Philips In-System Programming facility has made in-system programming in an embedded application possible with a minimum of additional expense in components and circuit board area. The ISP function uses five pins. Only a small connector needs to be available to interface your application to an external circuit in order to use this feature.

80C51 8-bit microcontroller with two-clock core**P89LPC932****8 KB 3 V low-power Flash with 512-byte data EEPROM**

In-Application Programming method (IAP)

Several In-Application Programming (IAP) calls are available for use by an application program to permit selective erasing and programming of Flash sectors, pages, security bits, configuration bytes, and device id. All calls are made through a common interface, PGM_MTP. The programming functions are selected by setting up the microcontroller's registers before making a call to PGM_MTP at FF00H.

USER CONFIGURATION BYTES

A number of user-configurable features of the LPC932 must be defined at power-up and therefore cannot be set by the program after start of execution. These features are configured through the use of the Flash byte UCFG1. Please see the *User's Manual* for additional details.

USER SECTOR SECURITY BYTES

There are eight User Sector Security Bytes each corresponding to one sector. Please see the *User's Manual* for additional details.

80C51 8-bit microcontroller with two-clock core
8 KB 3 V low-power Flash with 512-byte data EEPROM

P89LPC932

ABSOLUTE MAXIMUM RATINGS

PARAMETER	RATING	UNIT
Temperature under bias	-55 to +125	°C
Storage temperature range	-65 to +150	°C
Voltage on Xtal1, Xtal2 pin to V_{SS}	$V_{DD}+0.5$	V
Voltage on any other pin to V_{SS}	-0.5 to +5.5	V
Maximum I_{OL} per I/O pin	20	mA
Power dissipation (based on package heat transfer, not device power consumption)	1.5	W

Notes:

1. Stresses above those listed under Absolute Maximum Ratings may cause permanent damage to the device. This is a stress rating only and functional operation of the device at these or any conditions other than those described in the AC and DC Electrical Characteristics section of this specification are not implied.
2. This product includes circuitry specifically designed for the protection of its internal devices from the damaging effects of excessive static charge. Nonetheless, it is suggested that conventional precautions be taken to avoid applying greater than the rated maximum.
3. Parameters are valid over operating temperature range unless otherwise specified. All voltages are with respect to V_{SS} unless otherwise noted.

80C51 8-bit microcontroller with two-clock core**P89LPC932****8 KB 3 V low-power Flash with 512-byte data EEPROM****DC ELECTRICAL CHARACTERISTICS** $V_{DD} = 2.4 \text{ V}$ to 3.6 V unless otherwise specified; $T_{amb} = 0 \text{ }^{\circ}\text{C}$ to $+70 \text{ }^{\circ}\text{C}$ for commercial, $-40 \text{ }^{\circ}\text{C}$ to $+85 \text{ }^{\circ}\text{C}$ for industrial, unless otherwise specified.

SYMBOL	PARAMETER	TEST CONDITIONS	LIMITS			UNIT
			MIN	TYP ¹	MAX	
I_{DD}	Power supply current, operating	3.6 V, 12 MHz ¹¹	-	15	25	mA
I_{ID}	Power supply current, Idle mode	3.6 V, 12 MHz ¹¹	-	1	4	mA
I_{PD}	Power supply current, Power-down mode, voltage comparators powered down	3.6 V ¹¹	-	-	tbid	μA
I_{PD1}	Power supply current, Total Power-down mode	3.6 V ¹¹	-	1	5	μA
V_{DDR}	Vdd rise time		-	-	2	mV/ μs
V_{DDF}	Vdd fall time		-	-	50	mV/ μs
V_{RAM}	RAM keep-alive voltage		1.5	-	-	V
V_{IL}	Input low voltage (TTL input)	$2.4 \text{ V} < V_{DD} < 3.6 \text{ V}$	-0.5	-	$0.22V_{DD} - 0.1$	V
V_{IL1}	Negative going threshold (Schmitt input)		$0.22V_{DD}$	$0.4V_{DD}$	-	V
V_{IH}	Input high voltage (TTL input)		$0.7V_{DD} + 0.1$	-	5.5	V
V_{IH1}	Positive going threshold (Schmitt input)		-	$0.6V_{DD}$	$0.7V_{DD}$	V
HYS	Hysteresis voltage (Port 1)		-	$0.2V_{DD}$	-	V
V_{OL}	Output low voltage all ports ^{5, 9}	$I_{OL} = 20 \text{ mA}; V_{DD} = 2.4 \text{ V}$	-	-	1.0	V
		$I_{OL} = 3.2 \text{ mA}; V_{DD} = 2.4 \text{ V}$	-	-	0.3	V
V_{OH}	Output high voltage, all ports ³	$I_{OH} = -20 \text{ } \mu\text{A}; V_{DD} = 2.4 \text{ V}$	$V_{DD} - 0.2$	-	-	V
V_{OH1}	Output high voltage, all ports ⁴	$I_{OH} = -3.2 \text{ mA}; V_{DD} = 2.4 \text{ V}$	$V_{DD} - 0.7$	-	-	V
C_{IO}	Input/Output pin capacitance ¹⁰		-	-	15	pF
I_{IL}	Logical 0 input current, all ports ⁸	$V_{IN} = 0.4 \text{ V}$	-	-	-50	μA
I_{LI}	Input leakage current, all ports ⁷	$V_{IN} = V_{IL}$ or V_{IH}	-	-	± 10	μA
I_{TL}	Logical 1-to-0 transition current, all ports ^{3, 6}	$V_{IN} = 1.5 \text{ V}$ at $V_{DD} = 3.6 \text{ V}$	-30	-	-250	μA
R_{RST}	Internal reset pull-up resistor		40	-	225	k Ω
V_{BO}	Brownout trip voltage with $BOV = 1$, $BOPD = 0$	$2.4 \text{ V} < V_{DD} < 3.6 \text{ V}$	2.40	-	2.70	V
V_{REF}	Bandgap reference voltage		1.11	1.23	1.34	V
$t_C (V_{REF})$	Bandgap temperature coefficient		-	10	20	ppm/ $^{\circ}\text{C}$

Notes:

1. Typical ratings are not guaranteed. The values listed are at room temperature, 3 V.

2.

Active mode: $I_{CC(MAX)} = \text{tbid}$ Idle mode: $I_{CC(MAX)} = \text{tbid}$

3. Ports in quasi-bidirectional mode with weak pull-up (applies to all port pins with pull-ups). Does not apply to open drain pins.

4. Ports in PUSH-PULL mode. Does not apply to open drain pins.

5. In all output modes except high impedance mode.

6. Port pins source a transition current when used in quasi-bidirectional mode and externally driven from 1 to 0. This current is highest when V_{IN} is approximately 2 V.

7. Measured with port in high impedance mode.

8. Measured with port in quasi-bidirectional mode.

80C51 8-bit microcontroller with two-clock core**P89LPC932****8 KB 3 V low-power Flash with 512-byte data EEPROM**

9. Under steady state (non-transient) conditions, I_{OL} must be externally limited as follows:

Maximum I_{OL} per port pin: 20 mA

Maximum total I_{OL} for all outputs: 80 mA

Maximum total I_{OH} for all outputs: 5 mA

If I_{OL} exceeds the test condition, V_{OL} may exceed the related specification. Pins are not guaranteed to sink current greater than the listed test conditions.

10. Pin capacitance is characterized but not tested.

11. The I_{DD} , I_{ID} , and I_{PD} specifications are measured using an external clock with the following functions disabled: comparators, brownout detect, and watchdog timer.

80C51 8-bit microcontroller with two-clock core
8 KB 3 V low-power Flash with 512-byte data EEPROM
P89LPC932**AC ELECTRICAL CHARACTERISTICS**
 $T_{amb} = 0\text{ }^{\circ}\text{C}$ to $+70\text{ }^{\circ}\text{C}$ for commercial, $-40\text{ }^{\circ}\text{C}$ to $+85\text{ }^{\circ}\text{C}$ for industrial, unless otherwise specified.¹

SYMBOL	FIGURE (S)	PARAMETER	Variable Clock		f _{osc} = 12 MHz		UNIT
			MIN	MAX	MIN	MAX	
f _{RCOSC}		Internal RC oscillator frequency	7.189	7.557	7.189	7.557	MHz
f _{WDOSC}		Internal watchdog oscillator frequency	280	480	280	480	KHz
f _{OSC}		Oscillator frequency	0	12	-	-	MHz
t _{CLCL}	25	CLock cycle	83	-	-	-	ns
f _{LPEP}		LPEP active frequency	0	4	-	-	MHz
Glitch Filter							
		P1.5(RST) pin glitch rejection	-	50	-	50	ns
		P1.5(RST) pin signal acceptance	125	-	125	-	ns
		Glitch rejection - any pin except P1.5(RST)		15		15	ns
		Signal acceptance - any pin except P1.5(RST)	50	-	50	-	ns
External Clock							
t _{CHCX}	25	High time	33	t _{CLCL} - t _{CLCX}	33	-	ns
t _{CLCX}	25	Low time	33	t _{CLCL} - t _{CHCX}	33	-	ns
t _{CLCH}	25	Rise time	-	8	-	8	ns
t _{CHCL}	25	Fall Time	-	8	-	8	ns
Shift Register(UART mode 0)							
t _{XLXL}		Serial port clock cycle time	16 t _{CLCL}	-	1333	-	ns
t _{QVXH}		Output data set-up to clock rising edge	13 t _{CLCL}	-	1083	-	ns
t _{XHQX}		Output data hold after clock rising edge	-	t _{CLCL} + 20	-	103	ns
t _{XHDX}		Input data hold after clock rising edge	-	0	-	0	ns
t _{DVXH}		Input data valid to clock rising edge	150	-	150	-	ns
SPI Interface							
f _{SPI}		Operating frequency - 2.0 MHz (Master) - 2.0 MHz (Slave) - 3.0 MHz (Master) - 3.0 MHz (Slave)	- 0 - 0	- 2.0 - 3.0	- 0 - 0	- 2.0 - 3.0	MHz
t _{SPICYC}	20, 21, 22, 23	Cycle time - 2.0 MHz (Master) - 2.0 MHz (Slave) - 3.0 MHz (Master) - 3.0 MHz (Slave)	- 500 - 333	- - - -	- 500 - 333	- - - -	ns
t _{SPILEAD}	22, 23	Enable lead time (Slave) - 2.0 MHz - 3.0 MHz	250 240	- -	250 240	- -	ns
t _{SPILAG}	22, 23	Enable lag time (Slave) - 2.0 MHz - 3.0 MHz	250 240	- -	250 240	- -	ns
t _{SPICLKH}	20, 21, 22, 23	SPICLK high time - Master - Slave	340 190	- -	340 190	- -	ns
t _{SPICLKL}	20, 21, 22, 23	SPICLK low time - Master - Slave	340 190	- -	340 190	- -	ns
t _{SPIDSU}	20, 21, 22, 23	Data set-up time (Master or Slave)	100	-	100	-	ns
t _{SPIDH}	20, 21, 22, 23	Data hold time (Master or Slave)	100	-	100	-	ns
t _{SPIA}	22, 23	Access time (Slave)	0	120	0	120	ns

80C51 8-bit microcontroller with two-clock core
8 KB 3 V low-power Flash with 512-byte data EEPROM

P89LPC932

SYMBOL	FIGURE (S)	PARAMETER	Variable Clock		f _{osc} = 12 MHz		UNIT
			MIN	MAX	MIN	MAX	
t _{SPIDIS}	22, 23	Disable time (Slave) - 2.0 MHz - 3.0 MHz	0	240	-	240	ns
t _{SPIDV}	20, 21, 22, 23	Enable to output data valid - 2.0 MHz - 3.0 MHz	-	240	-	240	ns
t _{SPIOH}	20, 21, 22, 23	Output data hold time	0	-	0	-	ns
t _{SPIR}	20, 21, 22, 23	Rise time - SPI outputs (SPICLK, MOSI, MISO) - SPI inputs (SPICLK, MOSI, MISO, \overline{SS})	-	100	-	100	ns
t _{SPIF}	20, 21, 22, 23	Fall time - SPI outputs (SPICLK, MOSI, MISO) - SPI inputs (SPICLK, MOSI, MISO, \overline{SS})	-	100	-	100	ns

Notes:

- Parameters are valid over operating temperature range unless otherwise specified.
- Parts are tested to 2 MHz, but are guaranteed to operate down to 0 Hz.

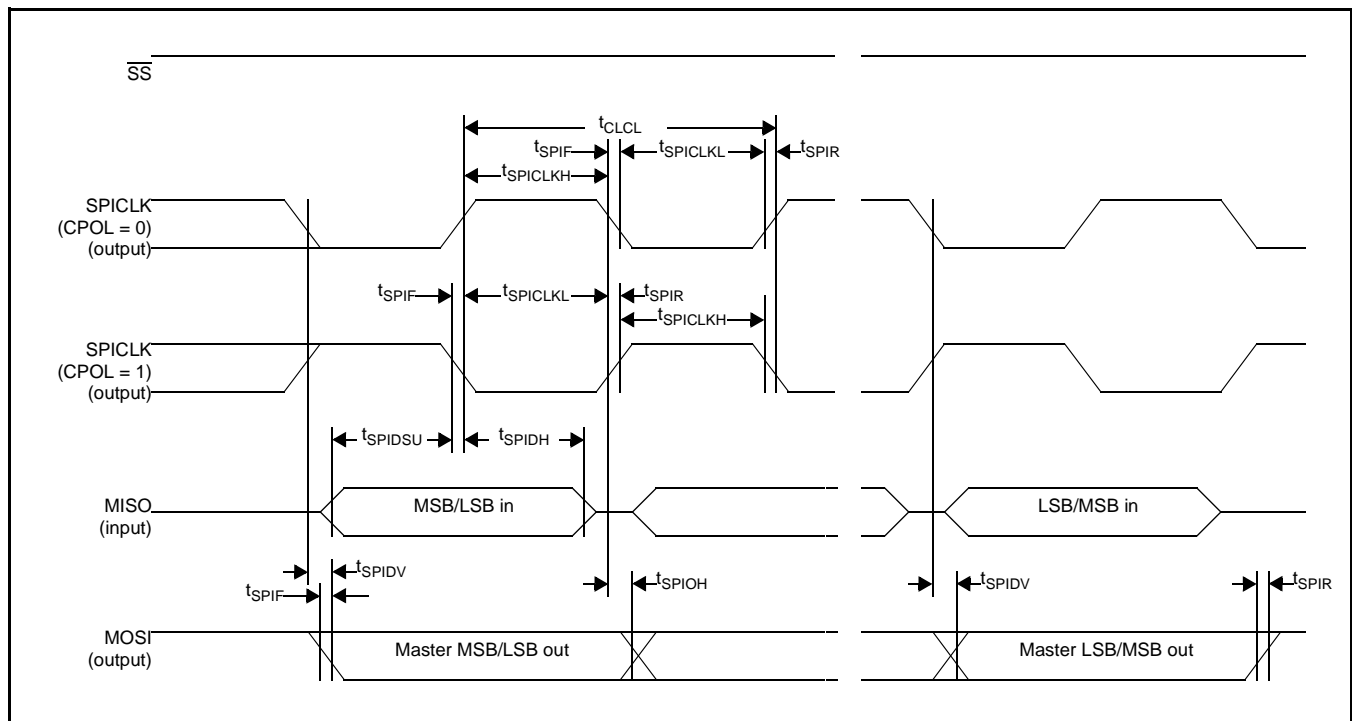

Figure 20: SPI Master timing (CPHA = 0)

80C51 8-bit microcontroller with two-clock core
8 KB 3 V low-power Flash with 512-byte data EEPROM

P89LPC932

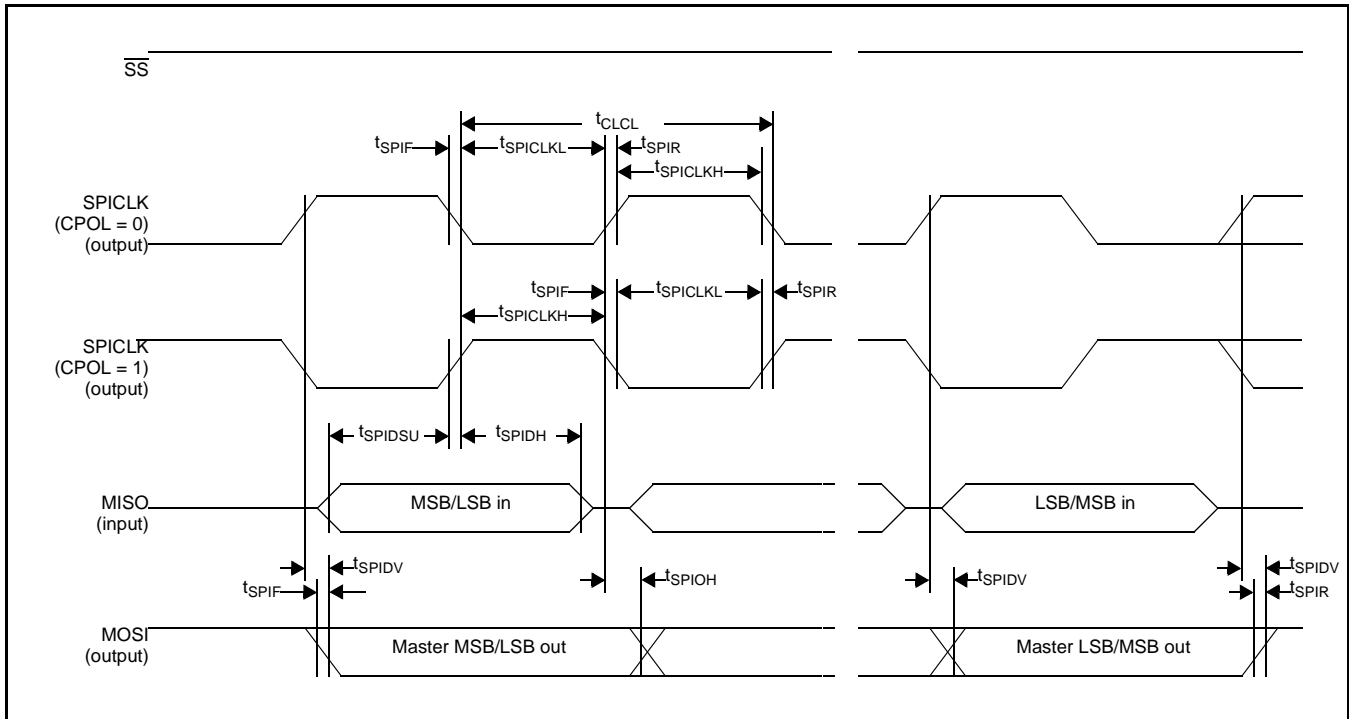

Figure 21: SPI Master timing (CPHA = 1)

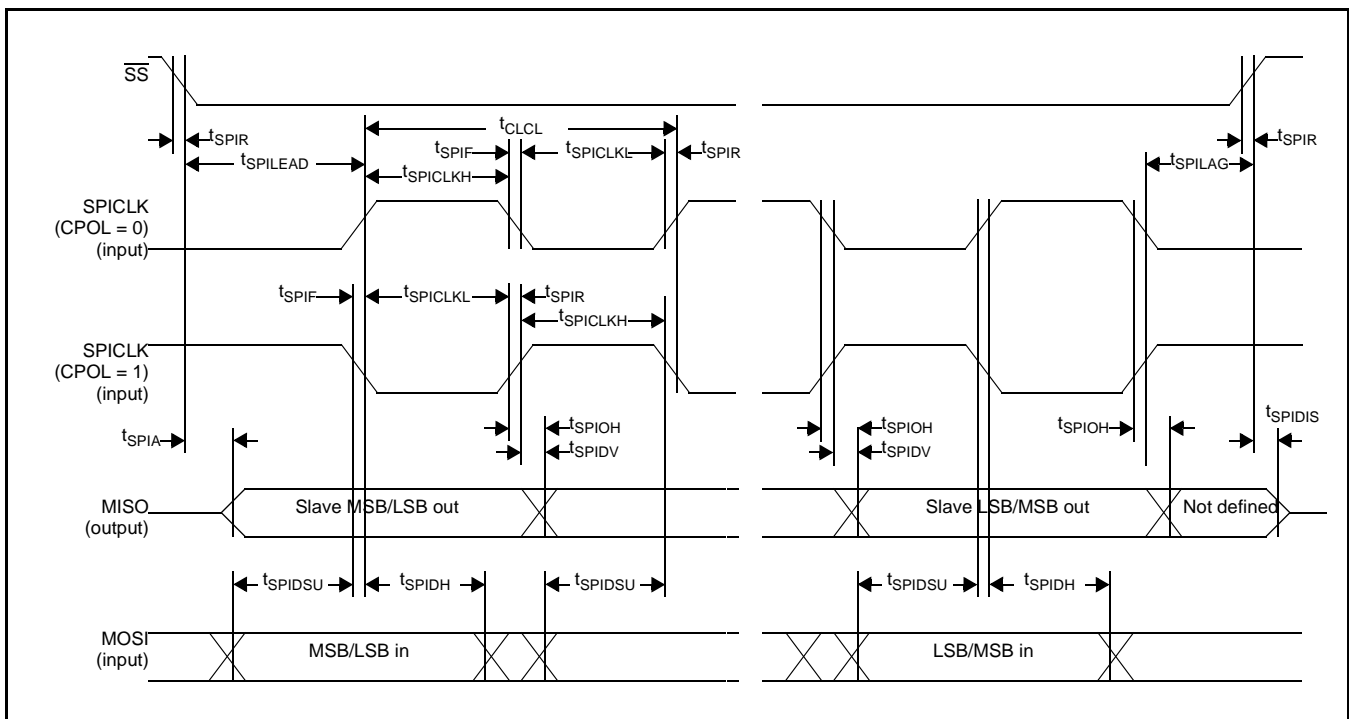

Figure 22: SPI Slave timing (CPHA = 0)

80C51 8-bit microcontroller with two-clock core
8 KB 3 V low-power Flash with 512-byte data EEPROM

P89LPC932

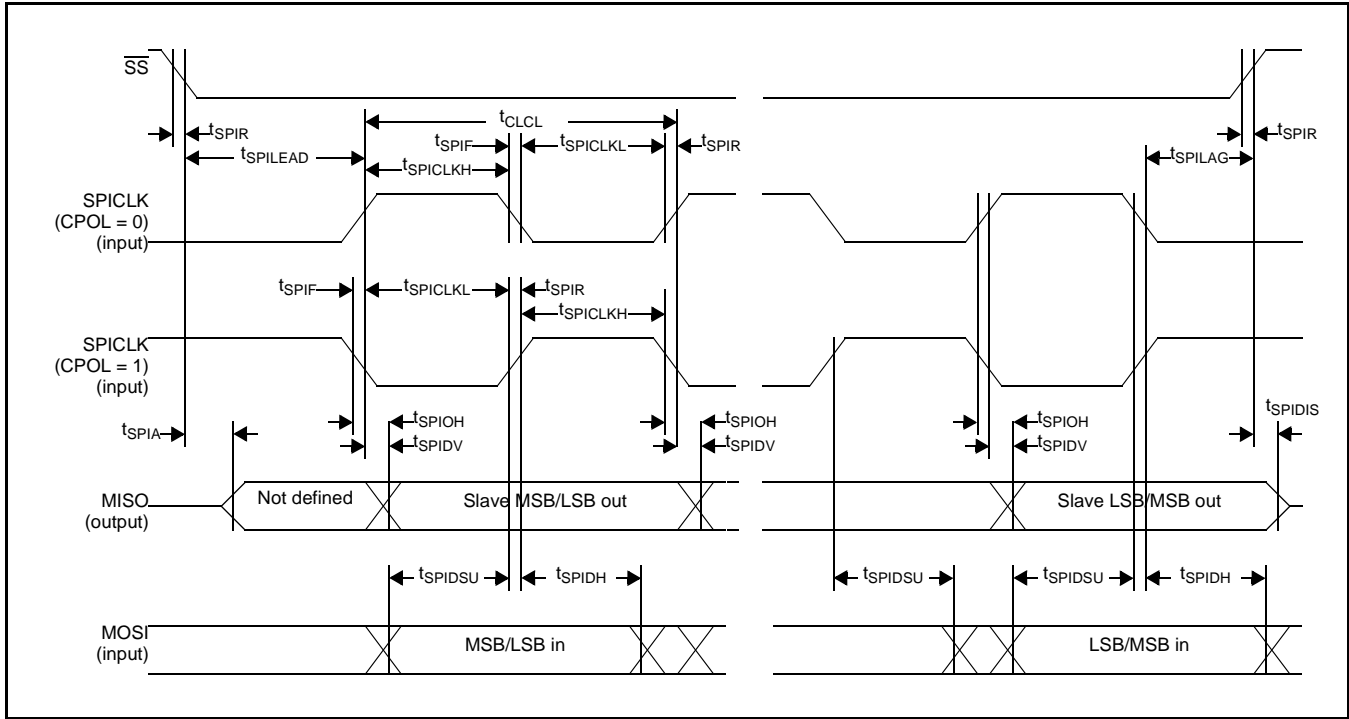

Figure 23: SPI Slave timing (CPHA = 1)

COMPARATOR ELECTRICAL CHARACTERISTICS

$V_{DD} = 2.4\text{ V to }3.6\text{ V}$ unless otherwise specified;

$T_{amb} = 0\text{ }^{\circ}\text{C to }+70\text{ }^{\circ}\text{C}$ for commercial, $-40\text{ }^{\circ}\text{C to }+85\text{ }^{\circ}\text{C}$ for industrial, unless otherwise specified

SYMBOL	PARAMETER	TEST CONDITIONS	LIMITS			UNIT
			MIN	TYP	MAX	
V_{IO}	Offset voltage comparator inputs		-	-	± 20	mV
V_{CR}	Common mode range comparator inputs		0	-	$V_{DD}-0.3$	V
CMRR	Common mode rejection ratio ¹		-	-	-50	dB
	Response time		-	250	500	ns
	Comparator enable to output valid		-	-	10	μs
I_{IL}	Input leakage current, comparator	$0 < V_{IN} < V_{DD}$	-	-	± 10	μA

Notes:

1. This parameter is characterized, but not tested in production.

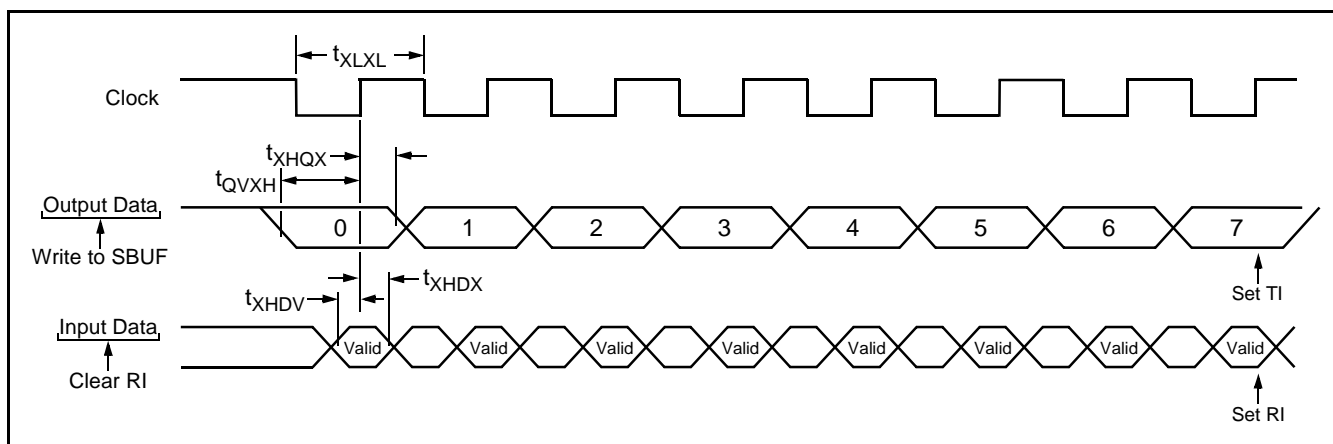

Figure 24: Shift Register Mode timing

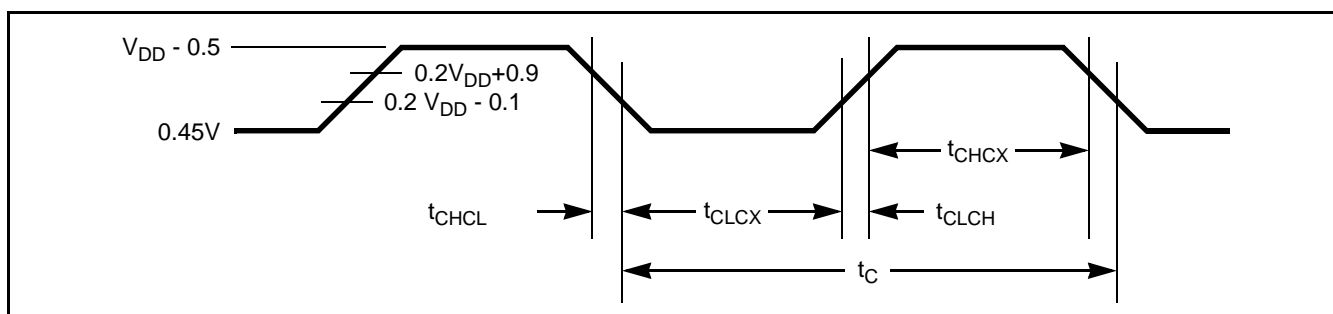

Figure 25: External clock timing

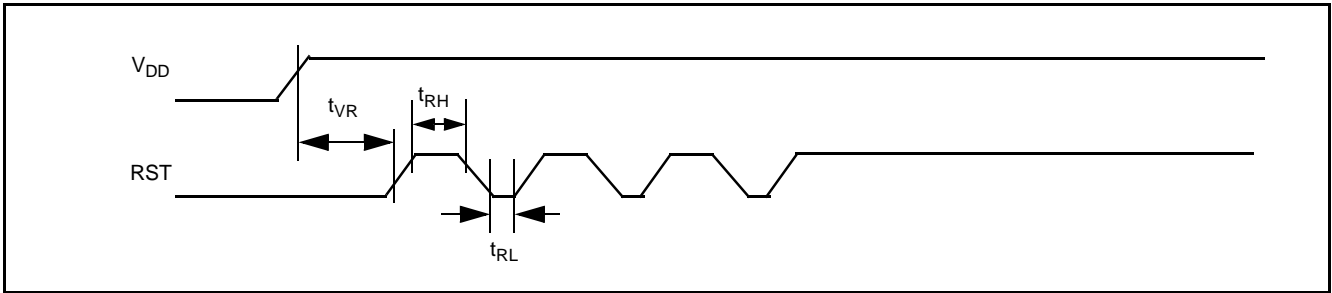

Figure 26: ISP Entry waveform

AC CHARACTERISTICS, ISP ENTRY MODE

V_{DD} = 2.4 V to 3.6 V unless otherwise specified;

T_{amb} = 0 to +70°C for commercial, -40 °C to +85 °C for industrial, unless otherwise specified

SYMBOL	PARAMETER	MIN	MAX	UNIT
t _{VR}	RST delay from V _{DD} active	50		μs
t _{RH}	RST HIGH time	1	32	μs
t _{RL}	RST LOW time	1		μs

80C51 8-bit microcontroller with two-clock core
8 KB 3 V low-power Flash with 512-byte data EEPROM

P89LPC932

PACKAGE OUTLINE

PLCC28: plastic leaded chip carrier; 28 leads

SOT261-2

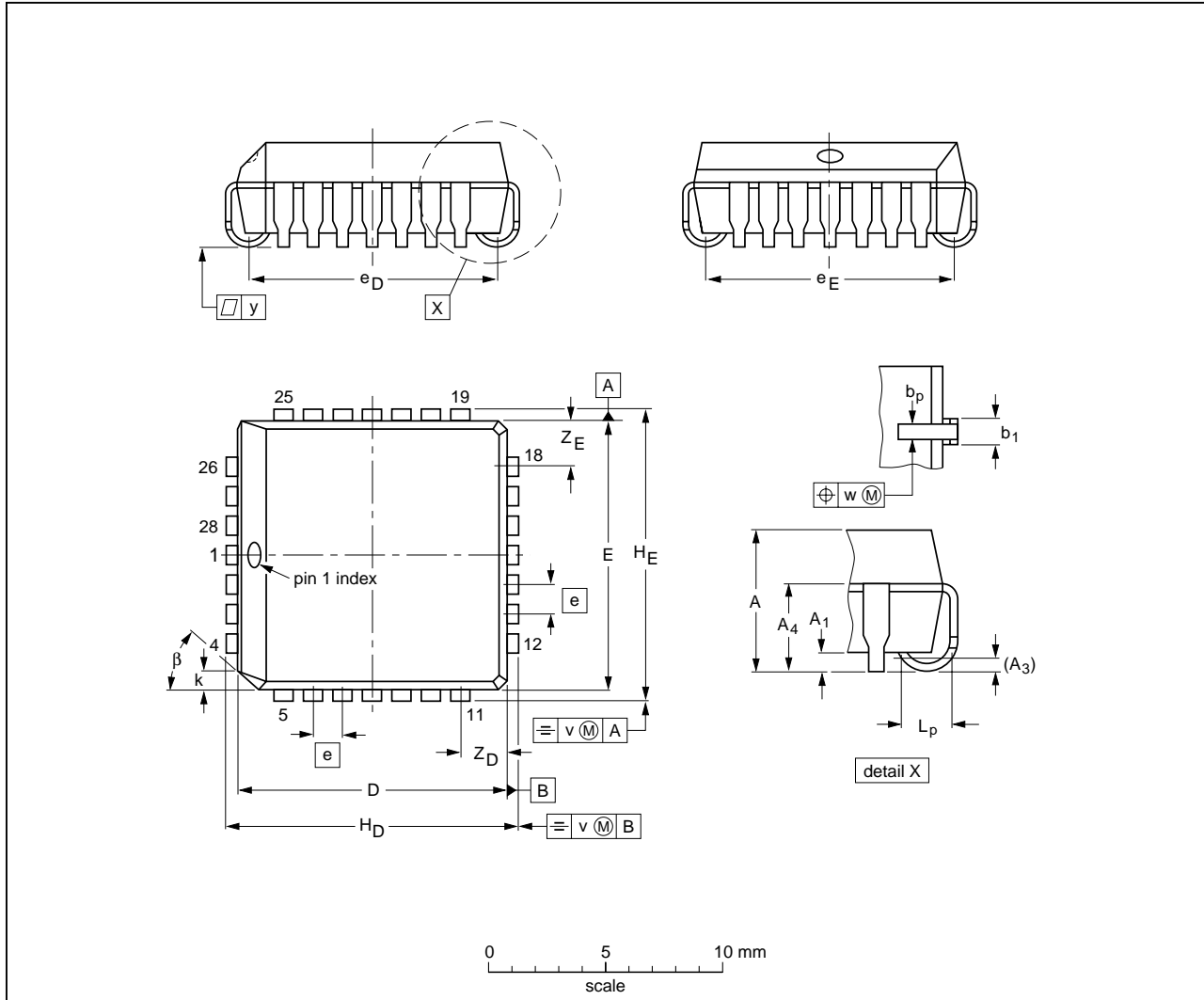

DIMENSIONS (mm dimensions are derived from the original inch dimensions)

UNIT	A	A ₁ min.	A ₃	A ₄ max.	b _p	b ₁	D ⁽¹⁾	E ⁽¹⁾	e	e _D	e _E	H _D	H _E	k	L _p	v	w	y	Z _D ⁽¹⁾ max.	Z _E ⁽¹⁾ max.	β
mm	4.57 4.19	0.51	0.25	3.05	0.53 0.33	0.81 0.66	11.58 11.43	11.58 11.43	1.27	10.92 9.91	10.92 9.91	12.57 12.32	12.57 12.32	1.22 1.07	1.44 1.02	0.18	0.18	0.1	2.16	2.16	45°
inches	0.180 0.165	0.02	0.01	0.12	0.021 0.013	0.032 0.026	0.456 0.450	0.456 0.450	0.05	0.43 0.39	0.43 0.39	0.495 0.485	0.495 0.485	0.048 0.042	0.057 0.040	0.007	0.007	0.004	0.085	0.085	

Note

1. Plastic or metal protrusions of 0.25 mm (0.01 inch) maximum per side are not included.

OUTLINE VERSION	REFERENCES			EUROPEAN PROJECTION	ISSUE DATE
	IEC	JEDEC	JEITA		
SOT261-2	112E08	MS-018	EDR-7319		99-12-27 01-11-15

80C51 8-bit microcontroller with two-clock core
8 KB 3 V low-power Flash with 512-byte data EEPROM

P89LPC932

TSSOP28: plastic thin shrink small outline package; 28 leads; body width 4.4 mm

SOT361-1

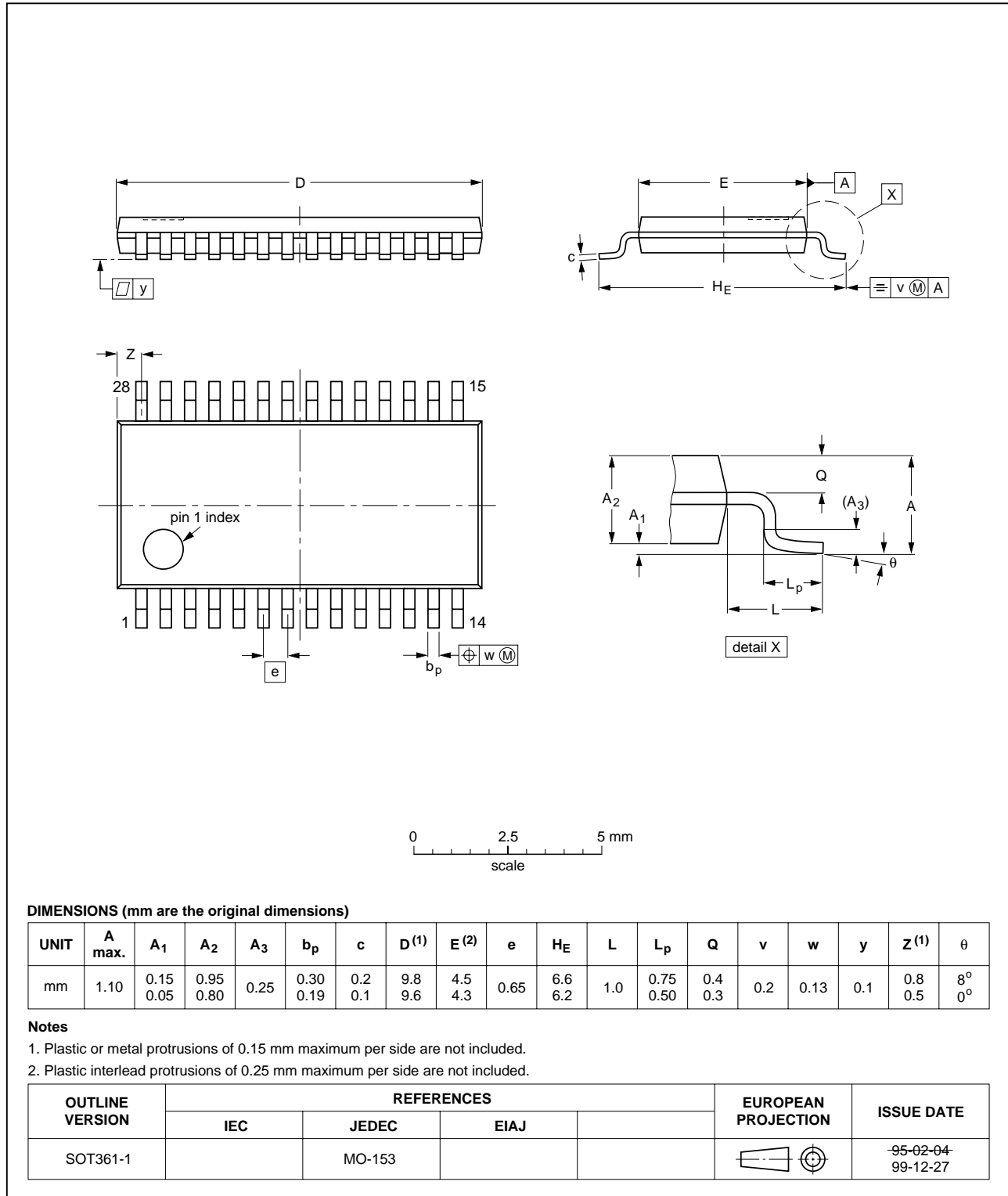

80C51 8-bit microcontroller with two-clock core

8 KB 3 V low-power Flash with 512-byte data EEPROM

P89LPC932

DATA SHEET STATUS

Level	Data sheet status ^[1]	Product status ^{[2],[3]}	Definition
I	Objective data	Development	This data sheet contains data from the objective specification for product development. Philips Semiconductors reserves the right to change the specification in any manner without notice.
II	Preliminary data	Qualification	This data sheet contains data from the preliminary specification. Supplementary data will be published at a later date. Philips Semiconductors reserves the right to change the specification without notice, in order to improve the design and supply the best possible product.
III	Product data	Production	This data sheet contains data from the product specification. Philips Semiconductors reserves the right to make changes at any time in order to improve the design, manufacturing and supply. Relevant changes will be communicated via a Customer Product/Process Change Notification (CPCN).

[1] Please consult the most recently issued data sheet before initiating or completing a design.

[2] The product status of the device(s) described in this data sheet may have changed since this data sheet was published. The latest information is available on the Internet at URL <http://www.semiconductors.philips.com>.

[3] For data sheets describing multiple type numbers, the highest-level product status determines the data sheet status.

DEFINITIONS

Short-form specification — The data in a short-form specification is extracted from a full data sheet with the same type number and title. For detailed information see the relevant data sheet or data handbook.

Limiting values definition — Limiting values given are in accordance with the Absolute Maximum Rating System (IEC 60134). Stress above one or more of the limiting values may cause permanent damage to the device. These are stress ratings only and operation of the device at these or at any other conditions above those given in the Characteristics sections of the specification is not implied. Exposure to limiting values for extended periods may affect device reliability.

Application information — Applications that are described herein for any of these products are for illustrative purposes only. Philips Semiconductors make no representation or warranty that such applications will be suitable for the specified use without further testing or modification.

DISCLAIMERS

Life support — These products are not designed for use in life support appliances, devices, or systems where malfunction of these products can reasonably be expected to result in personal injury. Philips Semiconductors customers using or selling these products for use in such applications do so at their own risk and agree to fully indemnify Philips Semiconductors for any damages resulting from such application.

Right to make changes — Philips Semiconductors reserves the right to make changes in the products - including circuits, standard cells, and/or software - described or contained herein in order to improve design and/or performance. When the product is in full production (status 'Production'), relevant changes will be communicated via a Customer Product/Process Change Notification (CPCN). Philips Semiconductors assumes no responsibility or liability for the use of any of these products, conveys no licence or title under any patent, copyright, or mask work right to these products, and makes no representations or warranties that these products are free from patent, copyright, or mask work right infringement, unless otherwise specified.

LICENCES

Purchase of Philips I²C components



Purchase of Philips I²C components conveys a license under the Philips' I²C patent to use the components in the I²C system provided the system conforms to the I²C specification defined by Philips. This specification can be ordered using the code 9398 393 40011.

80C51 8-bit microcontroller with two-clock core
8 KB 3 V low-power Flash with 512-byte data EEPROM

P89LPC932

CONTACT INFORMATION

For additional information, please visit <http://www.semiconductors.philips.com>.

For sales office addresses, send e-mail to: sales.addresses@www.semiconductors.philips.com.

Fax: +31 40 27 24825

© Koninklijke Philips Electronics N.V. 2002.
Printed in the U.S.A

All rights are reserved. Reproduction in whole or in part is prohibited without the prior written consent of the copyright owner.

The information presented in this document does not form part of any quotation or contract, is believed to be accurate and reliable and may be changed without notice. No liability will be accepted by the publisher for any consequence of its use. Publication thereof does not convey nor imply any license under patent- or other industrial or intellectual property rights.

Date of release: 2002 Oct 22

Document order number: 9397 750 10475



PHILIPS

Let's make things better.