



# LA7688

## Single-Chip CTV Signal-Processing Circuit for PAL and NTSC Formats

### Overview

The LA7688 integrates VIF, SIF, video, chrominance, and deflection processing circuits for PAL/NTSC format TV sets on a single chip and is provided in a 52-pin shrink package.

The VIF and SIF circuits achieve semi-adjustment-free operation, and are adjustment-free except for the VCO coil and the RF AGC circuit. The chrominance circuit can be made adjustment-free by using the LC89950 1H delay line IC. All the signal processing required for a multi-format color TV can be implemented by combining this product with the LA7642 SECAM decoder IC.

### Features

- [VIF] • PLL detector • Buzz canceller
- [SIF] • PLL detector • Audio switch
- [VIDEO] • Built-in trap • Built-in DL
- Aperture control
- Video switch (SVO output)
- Black expansion
- [CHROMA] • PAL/NT • Base band processing (adjustment free)
- Built-in bandpass filter

- [OSD] • Analog OSD
- [DEF] • Automatic 50/60 Hz discrimination
- Fixed vertical size • Double AFC
- Built-in sync separator circuit
- [Other features] • Sandcastle pulse (for the 1H delay line)
- fsc output (for SECAM systems)
- Primary color output

### Package Dimensions

unit: mm

3218-DIP52S

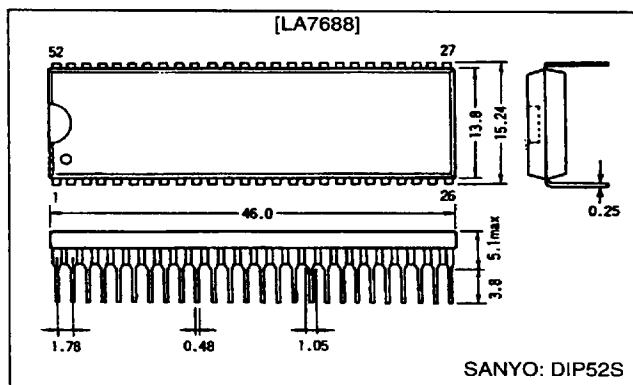

### Specifications

Maximum Ratings at Ta = 25°C

Parameter	Symbol	Conditions	Ratings	Unit
Maximum supply voltage	V <sub>40</sub> max		9	V
	V <sub>45</sub> max		9	V
Maximum supply current	I <sub>24</sub> max		16	mA
	I <sub>26</sub> max		5	mA
FBP input current	I <sub>32</sub> max		10	mA
	I <sub>26</sub> min		-5	V
FBP input voltage	I <sub>26</sub> min		-5	V
Allowable power dissipation	Pd max	Ta ≤ 65°C When mounted on a printed circuit board*	1.3	W
Operating temperature	Topr		-10 to +65	°C
Storage temperature	Tstg		-55 to +150	°C

Note : \* Printed circuit board size: 83 × 86 × 1.5 mm, material: Bakelite

Operating Conditions at Ta = 25°C

Parameter	Symbol	Conditions	Ratings	Unit
Recommended supply voltage	V <sub>40</sub>		7.6	V
	V <sub>45</sub>		7.6	V
Recommended supply current	I <sub>24</sub>		12	mA
Operating voltage range	V <sub>40</sub> op		7 to 8.2	V
	V <sub>45</sub> op		7 to 8.2	V
Operating current range	I <sub>24</sub> op		10 to 16	mA

**SANYO Electric Co., Ltd. Semiconductor Business Headquarters**

TOKYO OFFICE Tokyo Bldg., 1-10, 1 Chome, Ueno, Taito-ku, TOKYO, 110 JAPAN

7997076 0017490 025

82097HA(OT) No. 5635-1/6

LA7688

Operating Characteristics at  $T_a = 25^\circ\text{C}$ ,  $V_{CC40, 45} = 7.8\text{ V}$ ,  $I_{24} = 12\text{ mA}$

Parameter	Symbol	Conditions	Ratings			Unit
			min	typ	max	
[Circuit Voltages and Currents]						
Horizontal power-supply voltage	$V_{CCH}$	Deflection system ( $V_{24}$ )	6.4	6.9	7.4	V
Current drain	$I_{40}$		78	90	100	mA
	$I_{45}$		34	40	48	mA
[VIF Block]						
RF AGC maximum voltage	$V_{50H}$		7.5	7.8	7.8	V
RF AGC minimum voltage	$V_{50L}$			0.2	0.6	V
Input sensitivity	$V_i$			39	45	dB $\mu$
AGC range	GR		56	60		dB
Maximum allowable input	$V_{IN\max}$		95	100		dB $\mu$
Quiescent video output voltage	$V_B$		4.1	4.4	4.7	V
Synchronizing signal tip voltage	$V_{8tp}$		1.7	2.0	2.3	V
Video output amplitude	$V_O$		1.7	2.0	2.3	Vp-p
Black noise threshold voltage	$V_{BTH}$		1.0	1.3	1.7	V
Black noise clamp voltage	$V_{BCL}$		2.7	3.0	3.3	V
Output signal-to-noise ratio	S/N		48	52		dB
1.07 MHz beat level	C/S		40	44		dB
Frequency characteristics	$f_C$		6	9		MHz
Differential gain	DG			5	10	%
Differential phase	DP			6	10	deg
Quiescent AFT voltage	$V_7$		3.6	3.9	4.2	V
Maximum AFT voltage	$V_{7H}$		7.3	7.6	7.8	V
Minimum AFT voltage	$V_{7L}$		0	0.3	0.7	V
AFT detection sensitivity	$S_f$		10	15	20	mV/kHz
VIF input resistance	$R_i$	$f = 38.9\text{ MHz}$	1.0	1.3	1.6	k $\Omega$
VIF input capacitance	$C_i$	$f = 38.9\text{ MHz}$	2	3	5	pF
APC pull-in range (U)	$f_{PU}$		0.8	2.0		MHz
APC pull-in range (L)	$f_{PL}$			-2	-0.8	MHz
VCO1 maximum variation range	$\Delta f_{U1}$		0.8	2.0		MHz
	$\Delta f_{L1}$			-2.0	-0.8	MHz
SIF signal level	$S_{OUT}$		110	140	170	mVrms
VCO1 control sensitivity	$\beta$		2.4	4.8	9.6	kHz
[SIF Block]						
SIF limiting sensitivity	$V_i$ (lim)		40	46	52	dB $\mu$
FM detector output voltage	$V_O$ (FM)		390	500	710	mVrms
AMR	AMR		40	60		dB
Total harmonic distortion	THD			0.3	1.0	%
SIF S/N	S/N (SIF)		55	62		dB
FM detector range (L)	$W_{FML}$			2.5	4.0	MHz
FM detector range (H)	$W_{FMH}$		7.0	8.0		MHz
FM detector output variability	$\Delta V_O$		0	2.0	3.0	dB
[INT/EXT Switching Block]						
AFT EXT gain	$G_{AF}$		-0.7	-0.2	+0.3	dB
AFT EXT distortion	THD <sub>AF</sub>			0.03	0.5	%
System switch I-SE	$V_{1TH1}$	Notes: I = INT, E = EXT P/N = PAL/NTSC SE = SECAM	0		1.2	V
System switch I-P/N	$V_{1TH2}$		1.7		2.6	V
System switch E-P/N	$V_{1TH3}$		2.9		3.8	V
System switch E-SE	$V_{1TH4}$		4.1		5	V
[Video Switching Block]						
Video signal input 1 DC voltage	$V_{10DC}$		3.2	3.5	3.8	V
Video signal input 1 AC voltage	$V_{10AC}$			1.0		Vp-p
Video signal input 2 DC voltage	$V_{14DC}$		3.2	3.5	3.8	V
Video signal input 2 AC voltage	$V_{14AC}$			1.0		Vp-p
SVO pin DC voltage	$V_{16DC}$		2.5	2.8	3.1	V
SVO pin AC voltage	$V_{16AC}$		1.7	2.0	2.3	Vp-p

Continued on next page.

7997076 0017491 T61

No. 5635-2/6

LA7688

Continued from preceding page.

Parameter	Symbol	Conditions	Ratings			Unit
			min	typ	max	
[Filter Block]						
Filter automatic adjustment open voltage	V <sub>90PN</sub>	f <sub>SC</sub> = 4.43 MHz	3.3	3.8	4.3	V
S input threshold	V <sub>9TH</sub>		1.5	2.0	2.5	V
C-TRAP	G <sub>TRAP</sub>		-20	-26	-32	dB
C-BPF1	G <sub>BPF1</sub>		-5	-3	-1	dB
C-BPF2	G <sub>BPF2</sub>		-2	-1	0	dB
C-BPF3	G <sub>BPF3</sub>		-6	-4	-2	dB
Y-DL TIME1	T <sub>dy1</sub>	PAL	400	450	500	ns
Y-DL TIME2	T <sub>dy2</sub>	NTSC	410	460	510	ns
Y-DL TIME3	T <sub>dy3</sub>	S (PAL)	230	280	330	ns
Y-DL TIME4	T <sub>dy4</sub>	SECAM	510	560	610	ns
[Video Block]						
Contrast center	E <sub>CCEN</sub>		1.0	1.2	1.4	Vp-p
Contrast variation range	d <sub>GC</sub>		18	22	26	dB
Brightness minimum (0.5 V)	VB min		0.4	0.7	1.0	V
Brightness typical (2.5 V)	VB typ		1.9	2.2	2.5	V
Brightness maximum (4.5 V)	VB max		3.4	3.7	4.0	V
Soft control characteristics	d <sub>GSOFT</sub>		-6.0	-4.0	-2.0	dB
Sharp control characteristics	d <sub>GSHARP</sub>		4.5	7.5	10.5	dB
Y signal frequency characteristics (1)	BW1	S-VHS	3.9	4.4	4.9	MHz
Y signal frequency characteristics (2)	BW2	PAL	3.0	3.35	3.7	MHz
Y signal frequency characteristics (3)	BW3	NTSC	2.5	2.85	3.2	MHz
DC transmission ratio	d <sub>VAPL</sub>			100		%
Black expansion threshold	BS <sub>TH</sub>		40	50	60	IRE
Black expansion maximum gain	BS <sub>max</sub>		-20	-13	-6	IRE
[Chrominance Common]						
R-Y output DC voltage	V <sub>39DC</sub>		3.6	4.0	4.4	V
R-Y output AC voltage	E <sub>39AC</sub>		0.45	0.60	0.75	Vp-p
B-Y output DC voltage	V <sub>38DC</sub>		3.6	4.0	4.4	V
B-Y output AC voltage	E <sub>38AC</sub>		0.35	0.5	0.65	Vp-p
R-Y input DC voltage	V <sub>37DC</sub>		4.2	4.6	5.0	V
R-Y input AC voltage	E <sub>37AC</sub>		0.45	0.60	0.75	Vp-p
R-Y input AC range	E <sub>37ALC</sub>		160	200	250	mVp-p
B-Y input DC voltage	V <sub>36DC</sub>		4.2	4.6	5.0	V
B-Y input AC voltage	E <sub>36AC</sub>		0.35	0.5	0.65	Vp-p
B-Y input AC range	E <sub>36ALC</sub>		160	200	250	mVp-p
Residual color	E <sub>CMIN</sub>				200	mVp-p
Contrast color amplitude characteristics	d <sub>GCC</sub>		30	35	40	dB
RGB output DC difference voltage	d <sub>VC</sub>	With no chrominance signal input	-0.3	0	+0.3	V
RGB output DC voltage temperature characteristics	∂VC/∂T	With no chrominance signal input		0		mV/°C
RGB output residual high-frequency level	E <sub>car</sub>				0.2	Vp-p
RGB output residual carrier level	e <sub>car</sub>	With no chrominance signal input			0.3	Vp-p
f <sub>SC</sub> output pin DC voltage	V <sub>27OPN</sub>		4.5	5.0	5.3	V
f <sub>SC</sub> output level P	V <sub>27ACP</sub>	PAL	0.14	0.2	0.26	Vp-p
f <sub>SC</sub> output level N	V <sub>27ACN</sub>	NTSC	0.19	0.26	0.33	Vp-p
DEF COIN-L	V <sub>27LO</sub>		1.0	1.3	1.6	V
Crystal switching threshold	V <sub>27TH</sub>			400		μA
PAL switching threshold	V <sub>18PTH</sub>				0.6	V
NT switching threshold	V <sub>18NTH</sub>		0.9			V

Continued from preceding page.

LA7688

Continued from preceding page.

Parameter	Symbol	Conditions	Ratings			Unit
			min	typ	max	
[Chrominance System PAL Block]						
ACC amplitude characteristics 1	ACC1p		-2	+1	+4	dB
ACC amplitude characteristics 2	ACC2p		-4	0	+2	dB
Killer operating point	E KILp		-37	-30	-25	dB
Killer hysteresis	dE KILp		1	3	7	dB
RGB output level	E Bp	Chrominance: 50%, color: typical	4.1	4.6	5.1	Vp-p
Maximum RGB output	EBmaxp	Chrominance: 50%, color: maximum	5.4	5.9	6.4	Vp-p
APC pull-in range +	df scp+		500			Hz
APC pull-in range -	df scp-				-500	Hz
Demodulated output ratio B/R	B/Rp		1.50	1.78	2.00	double
Demodulated output ratio G/R	G/Rp	With no B-Y signal	-0.56	-0.51	-0.46	double
Demodulated output ratio G/B	G/Bp	With no R-Y signal	-0.21	-0.91	-0.17	double
Demodulation angle	RBp		85	90	95	deg
[Chrominance System NTSC Block]						
ACC amplitude characteristics 1	ACC1n		-2	+1	+4	dB
ACC amplitude characteristics 2	ACC2n		-4	0	+2	dB
ACC phase characteristics 1	PCC1n		-3	0	+3	deg
ACC phase characteristics 2	PCC2n		-5	0	+5	deg
Killer operating point	E KILn		-40	-34	-29	dB
Killer hysteresis	dE KILn		1	4	8	dB
RGB output level	E Bn	Chrominance: 50%, color: typical	3.4	3.9	4.4	Vp-p
Maximum RGB output	EBmaxn	Chrominance: 50%, color: maximum	5.0	5.5	6.0	Vp-p
APC pull-in range +	df scn+		350			Hz
APC pull-in range -	df scn-				-350	Hz
Tint control variation range	dP TI		-33		+50	deg
Demodulated output ratio R	R/Bn		0.81	0.90	0.99	double
Demodulated output ratio G	G/Bn		0.24	0.30	0.36	double
Demodulation angle RB	RBn		95	105	115	deg
Demodulation angle GB	GBn		-130	-120	-110	deg
[RGB Block]						
OSD input level	E <sub>OSD</sub>	Standard input, 100% white level		0.7		Vp-p
OSD input DC voltage	V <sub>OSD</sub>	With no signal	2.9	3.2	3.5	V
F-BLK input threshold level	V <sub>28TH</sub>		0.8	1.0	1.2	V
OSD output pedestal level difference	V <sub>OSDC</sub>		-0.3	0	+0.3	Vp-p
OSD output maximum	E <sub>OSDmax</sub>		4.3	4.8	5.3	Vp-p
OSD output minimum	E <sub>OSDmin</sub>		0.3	0.6	0.9	Vp-p
Character signal output frequency characteristics	BW <sub>OSD</sub>		5	7		MHz
TV-OSD crosstalk (C-Y)	CT <sub>TVC</sub>		50			dB
OSD-TV crosstalk (C-Y)	CT <sub>OSDC</sub>		40			dB
Character signal inter-character crosstalk	CT <sub>OSD</sub>		30			dB
[DEF Block]						
Vertical free-running period 50	TV <sub>FREE50</sub>		312.0	312.5	313.0	H
Vertical free-running period 60	TV <sub>FREE60</sub>		262.0	262.5	263.0	H
Vertical synchronization maximum period 50	TV <sub>max50</sub>	Horizontal synchronizing signal only	356.5	357.0	357.5	H
Vertical synchronization maximum period 60	TV <sub>max60</sub>	Horizontal synchronizing signal only	296.5	297.0	297.5	H
Vertical synchronization minimum period 50	TV <sub>min50</sub>		268.5	269.0	269.5	H
Vertical synchronization minimum period 60	TV <sub>min60</sub>		224.5	225.0	225.5	H
Vertical blanking peak value	V <sub>HVBL</sub>			0.6	1.0	V
Vertical blanking pulse width 50	PW <sub>BLK50</sub>		23	23.5	24	H
Vertical blanking pulse width 60	PW <sub>BLK60</sub>		19	19.5	20	H
Vertical output pulse width	PW <sub>VOU</sub>		8.0	8.5	9.0	H
Vertical output voltage H	V <sub>OUTH</sub>		5.3	5.6	5.9	V
Vertical output voltage M	V <sub>OUTM</sub>		4.0	4.3	4.6	V
Vertical output voltage L	V <sub>OUTL</sub>				0.3	V

Continued on next page.

LA7688

Continued from preceding page.

Parameter	Symbol	Conditions	Ratings			Unit
			min	typ	max	
Vertical external trigger load resistance	RTR		3.0	4.7		kΩ
Vertical automatic synchronization stop voltage	V <sub>SAS</sub>			1.4	1.9	V
Horizontal AFC gate release voltage	V <sub>GS</sub>			2.0	2.5	V
Vertical output start V <sub>CC</sub> voltage	SVV			4.2	4.7	V
Horizontal free-running deviation	Δf <sub>H</sub>		-150	0	+150	Hz
Horizontal free-running frequency V <sub>CC</sub> dependence	Δf <sub>H</sub> /V <sub>CC</sub>			2		Hz
Horizontal pull-in range	f <sub>HPLL</sub>		±450			Hz
Horizontal output start V <sub>CC</sub> voltage	S <sub>HV</sub>			4.8	5.2	V
AFC2 FBP peak value H	F <sub>BPH</sub>		6.0	6.5	7.0	V
AFC2 FBP peak value M	F <sub>BPM</sub>		3.2	3.7	4.2	V
AFC2 FBP peak value L	F <sub>BPL</sub>		-0.3	+0.2	+0.7	V
Horizontal output pulse width	P <sub>WHOUT</sub>		21.8	23.8	25.8	μs
Horizontal output phase maximum	HP <sub>max</sub>		14	17		μs
Horizontal output phase center	HP <sub>cen</sub>		4.8	5.8	6.8	μs
Horizontal output phase minimum	HP <sub>min</sub>			3.8	4.8	μs
Burst gate pulse width	P <sub>WBGP</sub>		3	4	5	μs
Burst gate pulse phase	T <sub>dBGP</sub>		-0.2	+0.3	+0.8	μs
50/60 Hz output voltage 50	V <sub>50</sub>			1.1	1.5	V
50/60 Hz output voltage 60	V <sub>60</sub>		3.8	4.1		V
50/60 Hz input voltage 50	V <sub>IN50</sub>		0.5			V
50/60 Hz input voltage 60	V <sub>IN60</sub>				7.0	V
SECAM V pulse peak value	SVH		1.8	2.2	2.6	V
SECAM V pulse width	SVW		11.0	11.5	12.0	H

LA7688

Test Circuit

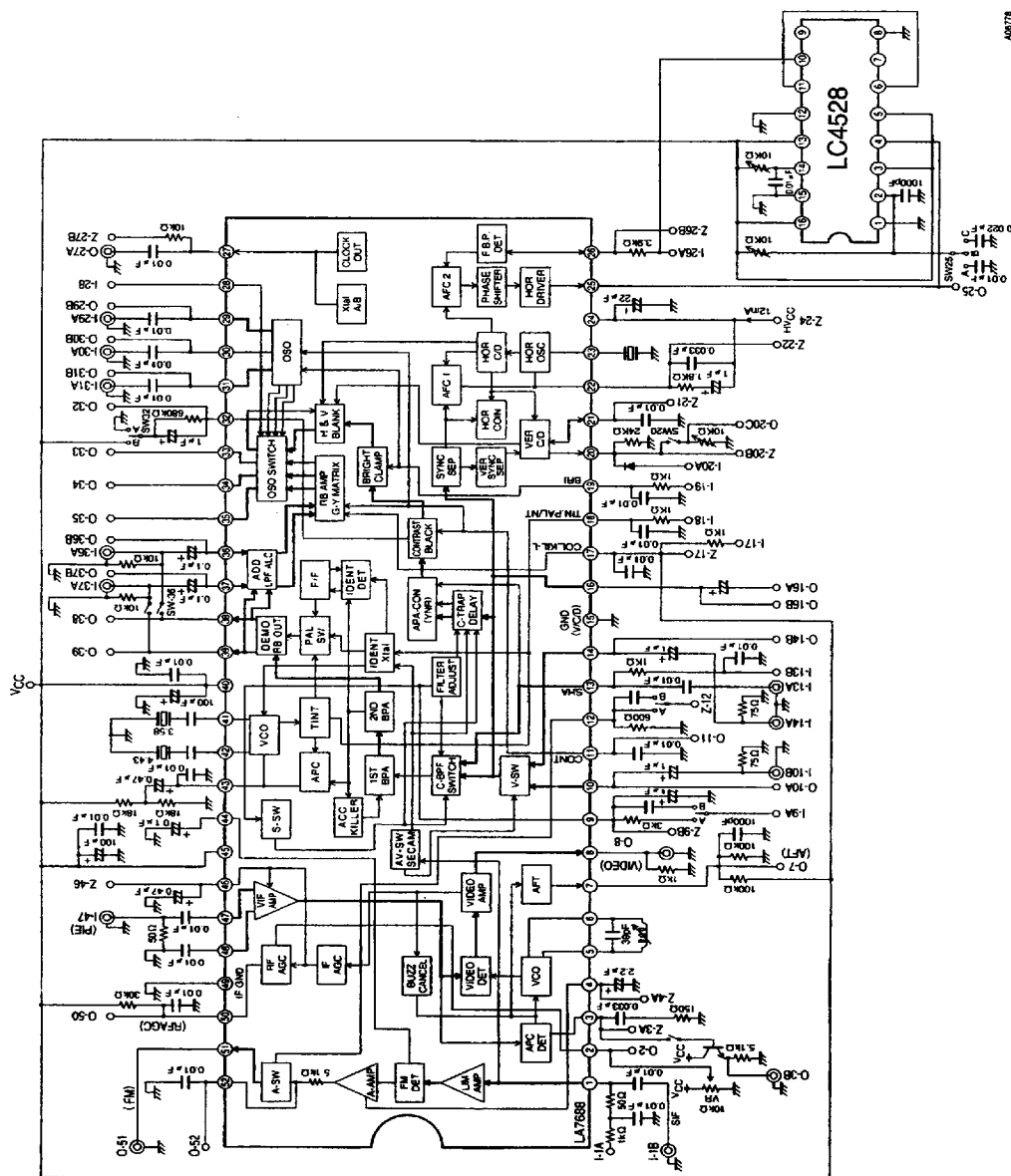

- No products described or contained herein are intended for use in surgical implants, life-support systems, aerospace equipment, nuclear power control systems, vehicles, disaster/crime-prevention equipment and the like, the failure of which may directly or indirectly cause injury, death or property loss.
- Anyone purchasing any products described or contained herein for an above-mentioned use shall:
  - ① Accept full responsibility and indemnify and defend SANYO ELECTRIC CO., LTD., its affiliates, subsidiaries and distributors and all their officers and employees, jointly and severally, against any and all claims and litigation and all damages, cost and expenses associated with such use;
  - ② Not impose any responsibility for any fault or negligence which may be cited in any such claim or litigation on SANYO ELECTRIC CO., LTD., its affiliates, subsidiaries and distributors or any of their officers and employees jointly or severally.
- Information (including circuit diagrams and circuit parameters) herein is for example only; it is not guaranteed for volume production. SANYO believes information herein is accurate and reliable, but no guarantees are made or implied regarding its use or any infringements of intellectual property rights or other rights of third parties.

This catalog provides information as of August, 1997. Specifications and information herein are subject to change without notice.

7997076 0017495 607

No. 5635-6/6

92363