



HIGH-SPEED CMOS BUS INTERFACE 10-BIT BUFFER

IDTQS74FCT2828AT/BT

FEATURES:

- CMOS power levels: <7.5mW static
- Undershoot clamp diodes on all outputs
- True TTL input and output compatibility
- Ground bounce controlled outputs
- Reduced output swing of 0 to 3.5V
- Built-in 25Ω series resistor outputs reduce reflection and other system noise
- A and B speed grades with 5ns t_{PD} for B
- I_{OL} = 12mA
- Available in QSOP package

DESCRIPTION:

The IDTQS74FCT2828T is a 10-bit buffer with 3-state outputs and a 25Ω resistor, useful for driving transmission lines and reducing system noise. The 2828T series parts can replace the 828T series to reduce noise in an existing design. All inputs have clamp diodes for undershoot noise suppression. All outputs have ground bounce suppression. Outputs will not load an active bus when V_{CC} is removed from the device.

FUNCTIONAL BLOCK DIAGRAM

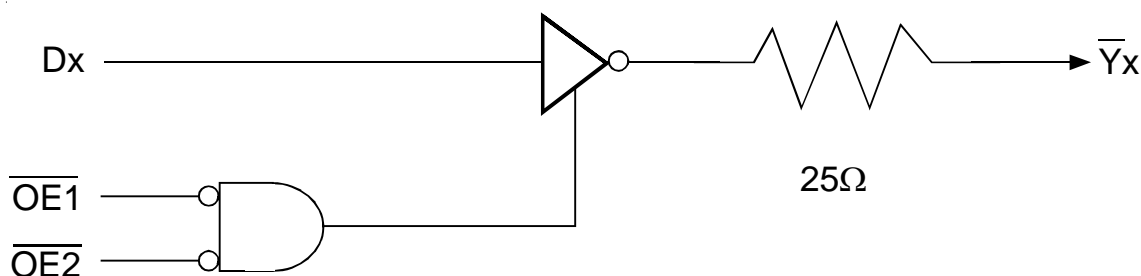

PIN CONFIGURATION

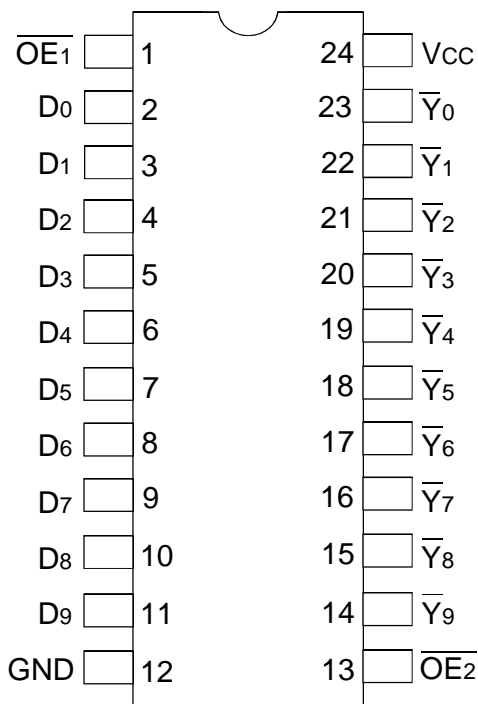

QSOP
TOP VIEW

ABSOLUTE MAXIMUM RATINGS⁽¹⁾

Symbol	Description	Max	Unit
V _{TERM}	Terminal Voltage with Respect to GND	-0.5 to +7	V
T _{STG}	Storage Temperature	-65 to +150	°C
I _{OUT}	DC Output Current Max Sink Current/Pin	120	mA
I _{IK}	Input Diode Current, V _{IN} < 0	-20	mA
I _{OK}	Output Diode Current, V _{OUT} < 0	-50	mA

NOTE:

- Stresses greater than those listed under ABSOLUTE MAXIMUM RATINGS may cause permanent damage to the device. This is a stress rating only and functional operation of the device at these or any other conditions above those indicated in the operational sections of this specification is not implied. Exposure to absolute maximum rating conditions for extended periods may affect reliability.

CAPACITANCE (T_A = +25°C, F = 1.0MHz)

Symbol	Parameter ⁽¹⁾	Conditions	Typ.	Max.	Unit
C _{IN}	Input Capacitance	V _{IN} = 0V	8	—	pF
C _{OUT}	Output Capacitance	V _{OUT} = 0V	8	—	pF

NOTE:

- This parameter is measured at characterization but not tested.

PIN DESCRIPTION

Pin Names	I/O	Description
D _x	I	Data Inputs
\bar{Y}_x	O	Data Outputs
\bar{OE}_x	I	Output Enables

FUNCTION TABLE⁽¹⁾

Inputs			Outputs	Function
\bar{OE}_1	\bar{OE}_2	D _x	\bar{Y}_x	
L	L	L	H	Enabled
L	L	H	L	Enabled
H	—	—	Z	High-Impedance
—	H	—	Z	High-Impedance

NOTE:

- H = HIGH
L = LOW
Z = High-Impedance

DC ELECTRICAL CHARACTERISTICS OVER OPERATING RANGE

Following Conditions Apply Unless Otherwise Specified:

Industrial: $T_A = -40^{\circ}\text{C}$ to $+85^{\circ}\text{C}$, $V_{CC} = 5.0\text{V} \pm 5\%$

Symbol	Parameter	Test Conditions		Min.	Typ. ⁽¹⁾	Max.	Unit
V_{IH}	Input HIGH Level	Guaranteed Logic HIGH Level		2	—	—	V
V_{IL}	Input LOW Level	Guaranteed Logic LOW Level		—	—	0.8	V
ΔV_T	Input Hysteresis	$V_{TLH} - V_{THL}$ for all inputs		—	0.2	—	V
I_{IH}	Input HIGH Current	$V_{CC} = \text{Max.}$	$0 \leq V_{IN} \leq V_{CC}$	—	—	± 5	μA
I_{IL}	Input LOW Current						
I_{OZ}	Off-State Output Current (Hi-Z)	$V_{CC} = \text{Max.}$	$0 \leq V_{IN} \leq V_{CC}$	—	—	± 5	μA
I_{OR}	Current Drive	$V_{CC} = \text{Max.}, V_{OUT} = 2.0\text{V}^{(2)}$		50	—	—	mA
V_{IC}	Input Clamp Voltage	$V_{CC} = \text{Min.}, I_{IN} = -18\text{mA}, T_A = 25^{\circ}\text{C}^{(2)}$		—	-0.7	-1.2	V
V_{OH}	Output HIGH Voltage	$V_{CC} = \text{Min.}$	$I_{OH} = -15\text{mA}$	2.4	—	—	V
V_{OL}	Output LOW Voltage	$V_{CC} = \text{Min.}$	$I_{OL} = 12\text{mA}$	—	—	0.5	V
$R_{OUT}^{(3)}$	Output Resistance	$V_{CC} = \text{Min.}$	$I_{OH} = -12\text{mA}$	18	25	40	Ω

NOTES:

- Typical values are at $V_{CC} = 5.0\text{V}$, $T_A = 25^{\circ}\text{C}$.
- This parameter is measured at characterization but not tested.
- R_{OUT} changed on March 8, 2002. See rear page for more information.

POWER SUPPLY CHARACTERISTICS

Following Conditions Apply Unless Otherwise Specified:

Industrial: $T_A = -40^{\circ}\text{C}$ to $+85^{\circ}\text{C}$, $V_{CC} = 5.0\text{V} \pm 5\%$

Symbol	Parameter	Test Conditions ⁽¹⁾	Min.	Max.	Unit
I_{CC}	Quiescent Power Supply Current	$V_{CC} = \text{Max.}$ freq = 0 $0\text{V} \leq V_{IN} \leq 0.2\text{V}$ or $V_{CC} - 0.2\text{V} \leq V_{IN} \leq V_{CC}$	—	1.5	mA
ΔI_{CC}	Supply Current per Input TTL Inputs HIGH	$V_{CC} = \text{Max.}$ $V_{IN} = 3.4\text{V}^{(2)}$ freq = 0	—	2	mA
I_{CCD}	Supply Current per Input per MHz	$V_{CC} = \text{Max.}$ Outputs Open and Enabled One Bit Toggling 50% Duty Cycle Other inputs at GND or $V_{CC}^{(3,4)}$	—	0.25	mA/MHz

NOTES:

- For conditions shown as Min. or Max., use the appropriate values specified under DC Electrical Characteristics.
- Per TLL driven input ($V_{IN} = 3.4\text{V}$).
- For flip-flops, I_{CCD} is measured by switching one of the data input pins so that the output changes every clock cycle. This is a measurement of device power consumption only and does not include power to drive load capacitance or tester capacitance.
- $I_{CC} = I_{QUIESCENT} + I_{INPUTS} + I_{DYNAMIC}$
 $I_{CC} = I_{CC} + \Delta I_{CC} D_H N_T + I_{CCD} (f_{CP}/2 + f_i N_i)$
 I_{CC} = Quiescent Current
 ΔI_{CC} = Power Supply Current for a TTL High Input ($V_{IN} = 3.4\text{V}$)
 D_H = Duty Cycle for TTL Inputs High
 N_T = Number of TTL Inputs at DH
 I_{CCD} = Dynamic Current Caused by an Output Transition Pair (HLH or LHL)
 f_{CP} = Clock Frequency for Register Devices (Zero for Non-Register Devices)
 f_i = Input Frequency
 N_i = Number of Inputs at f_i
 All currents are in milliamps and all frequencies are in megahertz.

SWITCHING CHARACTERISTICS OVER OPERATING RANGE⁽¹⁾

Symbol	Parameter ⁽²⁾	FCT2828AT		FCT2828BT		Unit
		Min.	Max.	Min.	Max.	
t _{PLH} t _{PHL}	Propagation Delay D _x to \bar{Y}_x	—	7.5	—	5	ns
t _{PLH} t _{PHL}	Propagation Delay D _x to \bar{Y}_x ^(2,3)	—	17	—	14	ns
t _{PZH} t _{PZL}	Output Enable Time $\bar{O}\bar{E}_x$ to \bar{Y}_x	—	12	—	8	ns
t _{PZH} t _{PZL}	Output Enable Time $\bar{O}\bar{E}_x$ to \bar{Y}_x ^(2,3)	—	23	—	18	ns
t _{PHZ} t _{PLZ}	Output Disable Time $\bar{O}\bar{E}_x$ to \bar{Y}_x ^(2,4)	—	9	—	6	ns
t _{PHZ} t _{PLZ}	Output Disable Time $\bar{O}\bar{E}_x$ to \bar{Y}_x ⁽²⁾	—	10	—	7	ns

NOTES:

1. C_{LOAD} = 50pF, R_{LOAD} = 500Ω unless otherwise noted.
2. This parameter is guaranteed by design but not tested.
3. C_{LOAD} = 300pF.
4. C_{LOAD} = 5pF.

TEST CIRCUITS AND WAVEFORMS

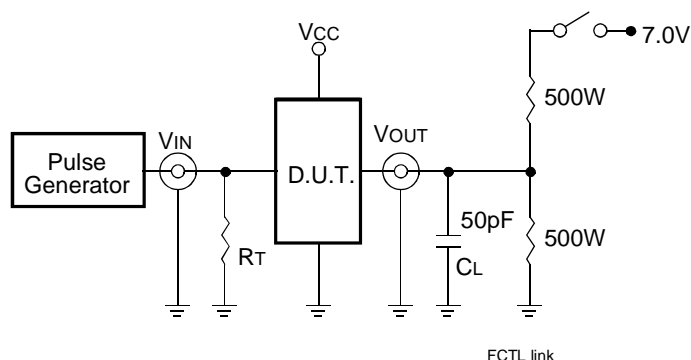

Test Circuits for All Outputs

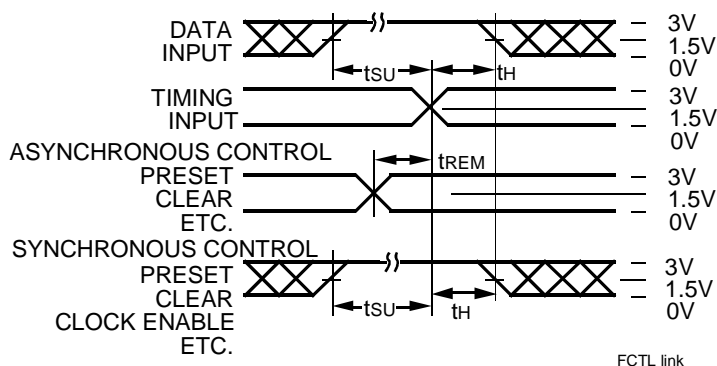

Set-Up, Hold, and Release Times

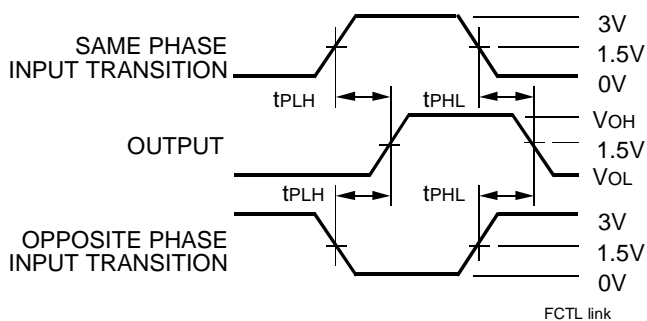

Propagation Delay

SWITCH POSITION

Test	Switch
Open Drain Disable Low Enable Low	Closed
All Other Tests	Open

DEFINITIONS:

CL = Load capacitance: includes jig and probe capacitance.
RT = Termination resistance: should be equal to Zout of the Pulse Generator.

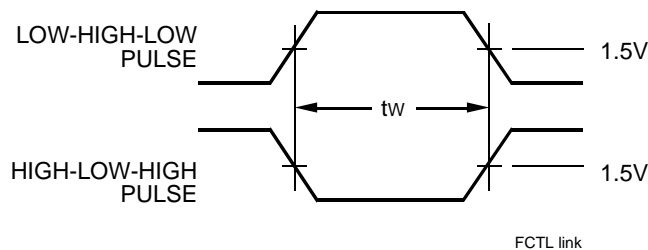

Pulse Width

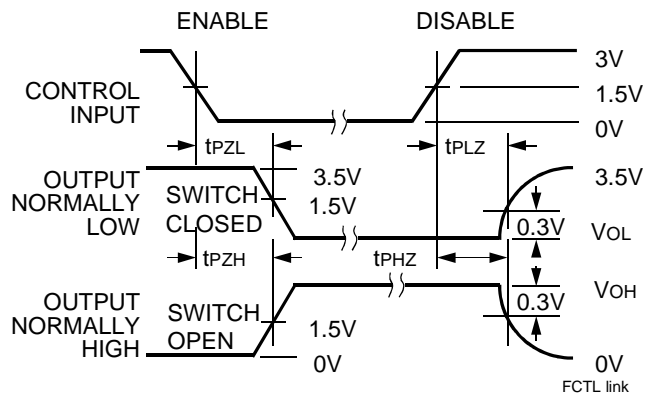

Enable and Disable Times

NOTES:

1. Diagram shown for input Control Enable-LOW and input Control Disable-HIGH.
2. Pulse Generator for All Pulses: Rate \leq 1.0MHz; $t_f \leq$ 2.5ns; $t_r \leq$ 2.5ns.

ORDERING INFORMATION

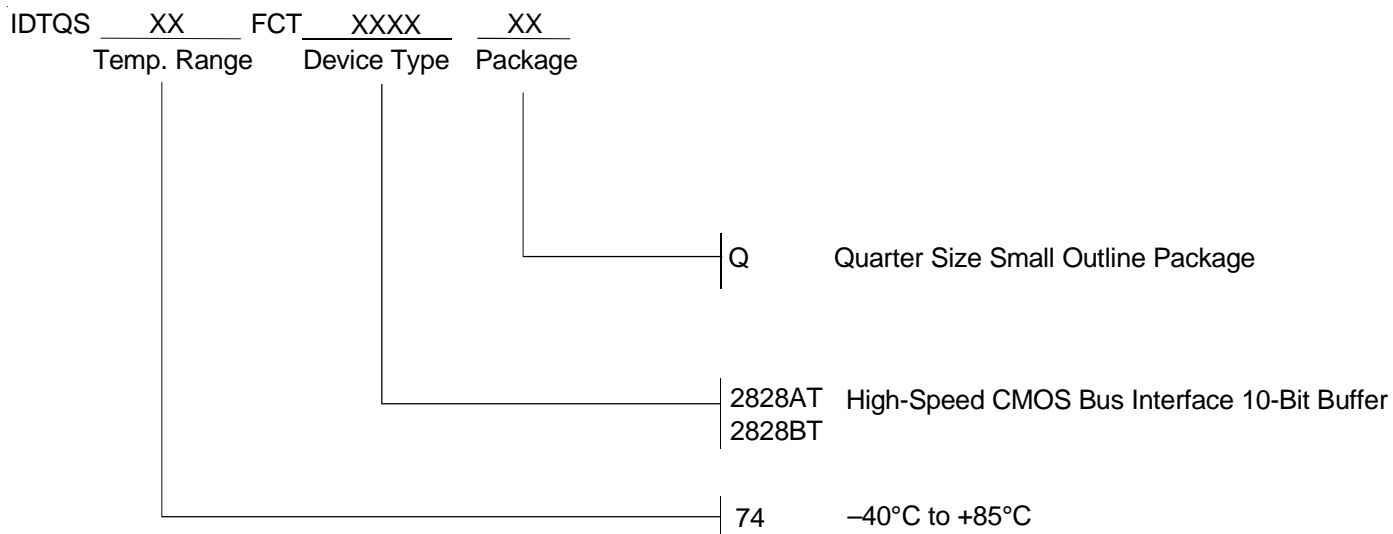

As per PCN L0201-02, the Output Resistance (R_{OUT}) specifications have changed as of March 8, 2002. The original specifications were:

Parameter	Description	Min.	Typ.	Max.	Unit
R _{OUT}	V _{CC} = Min, I _{OL} = -15mA	20	28	40	Ω



CORPORATE HEADQUARTERS
 2975 Stender Way
 Santa Clara, CA 95054

for SALES:
 800-345-7015 or 408-727-6116
 fax: 408-492-8674
 www.idt.com

for Tech Support:
 logichelp@idt.com
 (408) 654-6459