

CNZ1413

Integrated Photosensors

Overview

CNZ1413 are ultraminiature, highly reliable transmissive photosensors consisting of a high-efficiency GaAs infrared light emitting diode chip that is integrated with a high-sensitivity Si-integrated-photodetector chip in a double molded resin package.

Features

- Ultraminiature : 4.2 × 4.2 mm (height : 5.2 mm)
- Fast response : $t_{PHL} = 2.5\mu s$, $t_{PLH} = 6\mu s$ (typ.) (ON1413A)
- Highly precise position detection (slit width : 0.3 mm)
- Gap width : 1.2 mm
- With attachment positioning pin

Absolute Maximum Ratings (Ta = 25°C)

	Parameter	Symbol	Rated	Unit
Input (Light emitting diode)	Reverse voltage (DC)	V_R	6	V
	Forward current (DC)	I_F	50	mA
	Power dissipation	P_D^{*1}	75	mW
Output (Photo IC)	Output current	I_O	20	mA
	Output voltage	V_O	30	V
	Supply voltage	V_{CC}	17	V
	Power dissipation	P_C^{*2}	200	mW
Temperature	Operating ambient temperature	T_{opr}	-25 to +85	°C
	Storage temperature	T_{stg}	-40 to +100	°C

*1 Input power derating ratio is 1.0 mW/°C at Ta ≥ 25°C.

*2 Output power derating ratio is 2.67 mW/°C at Ta ≥ 25°C.

Pin Connection

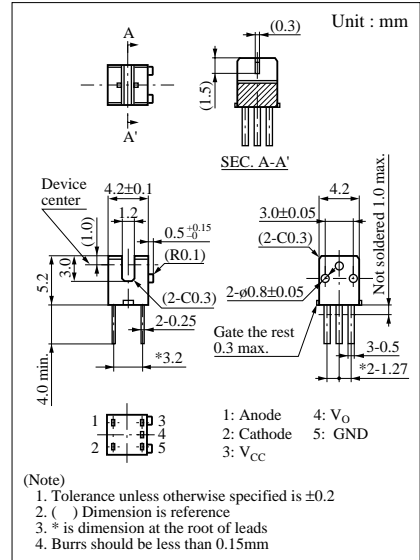
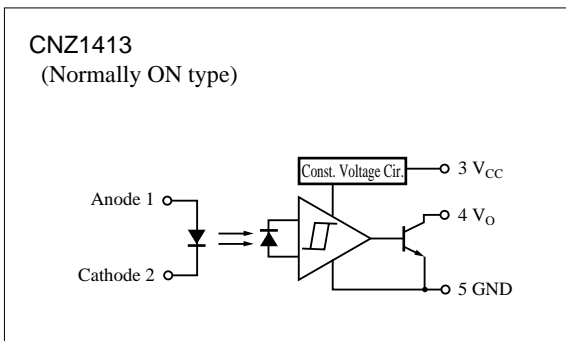

■ Electrical Characteristics (Ta = 25°C)

Parameter		Symbol	Conditions	min	typ	max	Unit
Input characteristics	Forward voltage (DC)	V_F	$I_F = 20\text{mA}$		1.2	1.4	V
	Reverse current (DC)	I_R	$V_R = 3\text{V}$			10	μA
Output characteristics	“H” Output current	I_{OH}	$V_{CC} = 5\text{V}, V_{OH} = 30\text{V}, I_F = 0\text{mA}$			100	μA
	“L” Output voltage	V_{OL}	$V_{CC} = 5\text{V}, I_{OL} = 20\text{mA}, I_F = 5\text{mA}$		0.15	0.4	V
	Operating power voltage	V_{CC}			4.5	17	V
	Low-level supply current	I_{CCL}	$V_{CC} = 5\text{V}, I_F = 5\text{mA}$		2.4	5	mA
	High-level supply current	I_{CCH}	$V_{CC} = 5\text{V}, I_F = 0\text{mA}$		0.8	3	mA
Transfer characteristics	Threshold input current	$I_{FH \rightarrow L}(I_{FL \rightarrow H})$	$V_{CC} = 5\text{V}$			5	mA
	Hysteresis	$I_{FLH}/I_{FHL}(I_{FHL}/I_{FLH})$	$V_{CC} = 5\text{V}$		0.7		
	Response time	$t_{PHL}(t_{PLH})^*$	$V_{CC} = 5\text{V}, I_F = 5\text{mA}, R_L = 1\text{k}\Omega$		2.5(3.5)		μs
$t_{PLH}(t_{PHL})^*$		$V_{CC} = 5\text{V}, I_{FP} = 5\text{mA}, R_L = 1\text{k}\Omega$		6(5)		μs	

Note) Normally ON type characteristics is shown, () shows Normally OFF type.

* Switching time measurement circuit

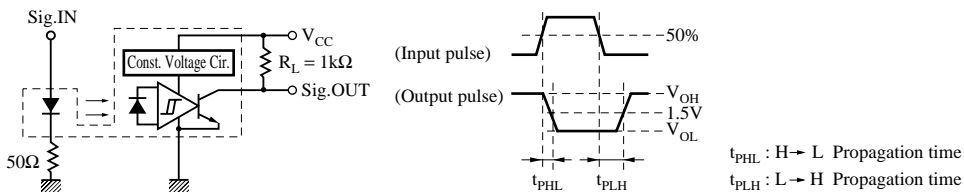

● Important Information for Soldering

1. Soldering Position

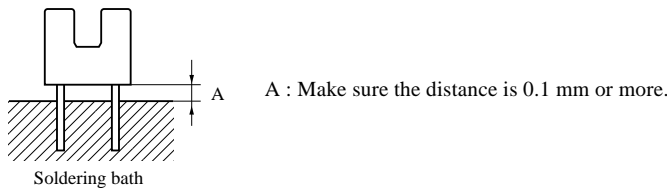

2. Solder Temperature and Soldering Time

Temperature : 260°C or less

Time : within 3 seconds

Note) Avoid using reflow soldering methods.

3. Other Issues

- 1) Soldering should not create excessive thermal or mechanical stress on the case package or leads. Excessive stress may cause changes in the shape or characteristics of the package or leads.
- 2) Be careful not to allow solder, flux, solvents, etc. to remain on the case package. Doing so may cause problems related to transmission characteristics, etc.

