

2SC3824, 2SC3824A

Silicon PNP Triple-Diffused Planar Type

High Breakdown Voltage, High Speed Switching

■ Features

- High speed switching
- High collector-base voltage (V_{CB0})
- "I Type" package configuration with a cooling fin for direct soldering on PC board of a small-size electronic equipment

■ Absolute Maximum Ratings ($T_c=25^\circ\text{C}$)

Item	Symbol	Value	Unit
Collector-base voltage	2SC3824	900	V
	2SC3824A	900	
Collector-emitter voltage	V_{CES}	900	V
Collector-emitter voltage	2SC3824	800	V
	2SC3824A	900	
Emitter-base voltage	V_{EBO}	7	V
Peak collector current	I_{CP}	2	A
Collector current	I_C	1	A
Collector power dissipation	$T_c=25^\circ\text{C}$	15	W
	$T_a=25^\circ\text{C}$	1.3	
Junction temperature	T_j	150	$^\circ\text{C}$
Storage temperature	T_{stg}	-55~+150	$^\circ\text{C}$

■ Electrical Characteristics ($T_c=25^\circ\text{C}$)

Item	Symbol	Condition	min.	typ.	max.	Unit
Collector cutoff current	I_{CB0}	$V_{CB}=900\text{ V}, I_E=0$			50	μA
Emitter cutoff current	I_{EBO}	$V_{EB}=7\text{ V}, I_C=0$			50	μA
Collector-emitter voltage	V_{CEO}	$I_C=1\text{ mA}, I_B=0$	800			V
		$I_C=1\text{ mA}, I_B=0$	900			
DC current gain	h_{FE1}	$V_{CE}=5\text{ V}, I_C=0.05\text{ A}$	6			
	h_{FE2}	$V_{CE}=5\text{ V}, I_C=0.5\text{ A}$	3			
Collector-emitter saturation voltage	$V_{CE(sat)}$	$I_C=0.2\text{ A}, I_B=0.04\text{ A}$			1.5	V
Base-emitter saturation voltage	$V_{BE(sat)}$	$I_C=0.2\text{ A}, I_B=0.04\text{ A}$			1	V
Transition frequency	f_T	$V_{CE}=10\text{ V}, I_C=0.05\text{ A}, f=1\text{ MHz}$		4		MHz
Turn-on time	t_{on}	$I_C=0.2\text{ A}$			1	μs
Storage time	t_{stg}	$I_{B1}=0.04\text{ A}, I_{B2}=-0.08\text{ A}$			3	μs
Collector current fall time	t_f	$V_{CC}=250\text{ V}$			1	μs

■ Package Dimensions

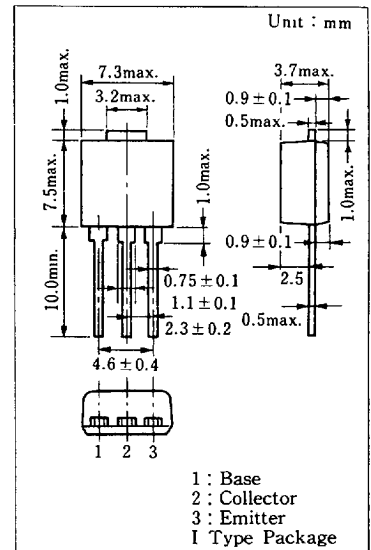

*Surface-mount type is also available.
(Refer to p.81.)

6932852 0016486 682

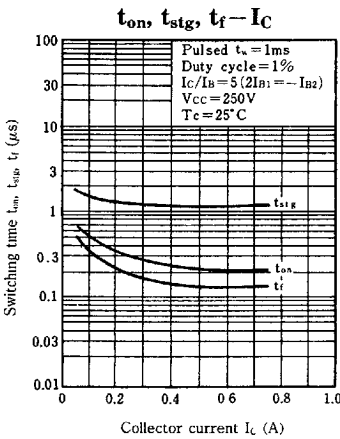
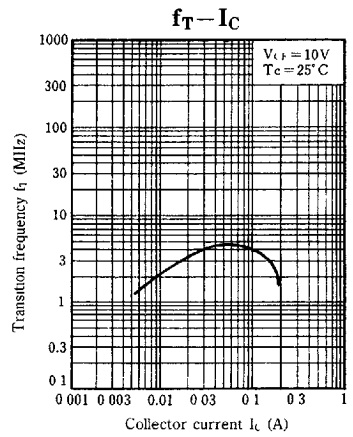
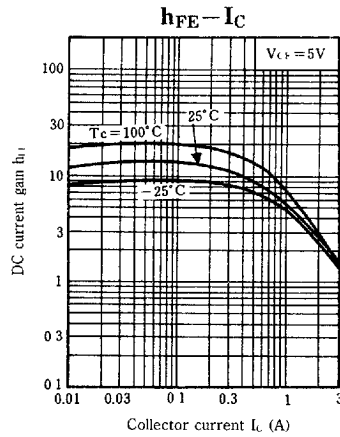
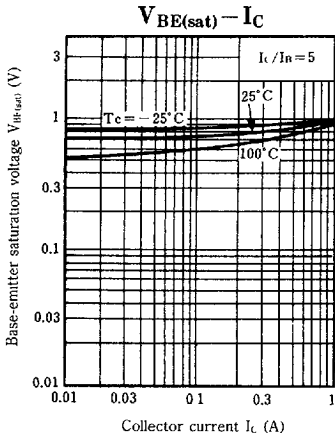
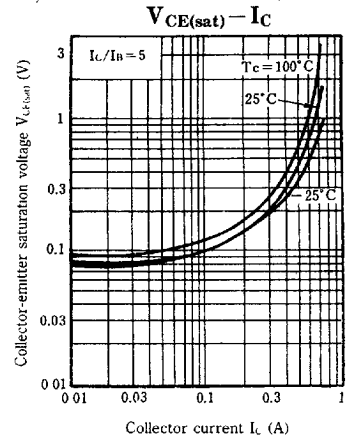
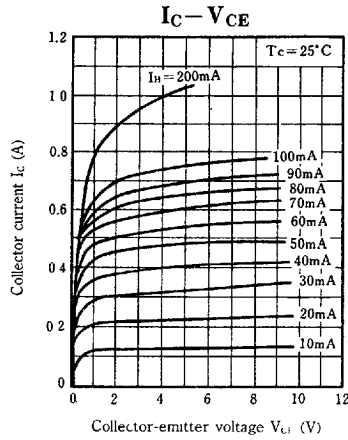
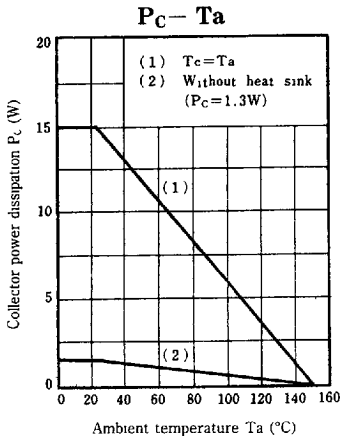

Safety operation area-forward bias (ASO)

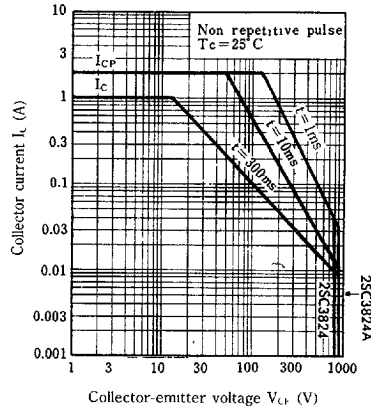

Safety operation area-reverse bias (ASO)

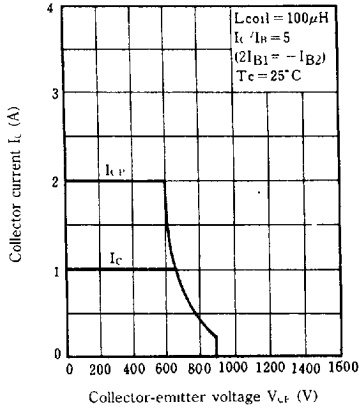

Measurement circuit of reverse bias ASO

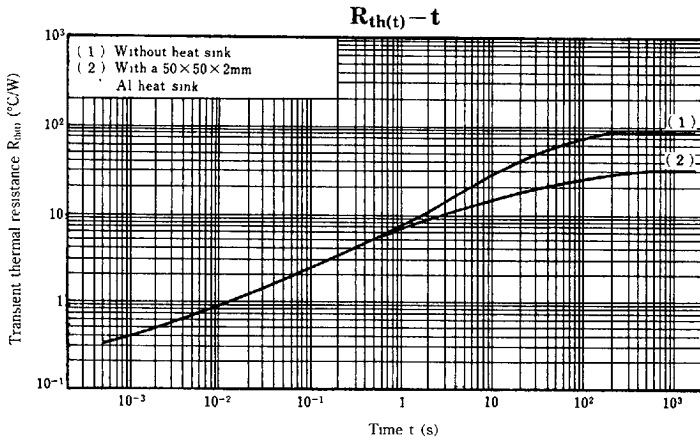
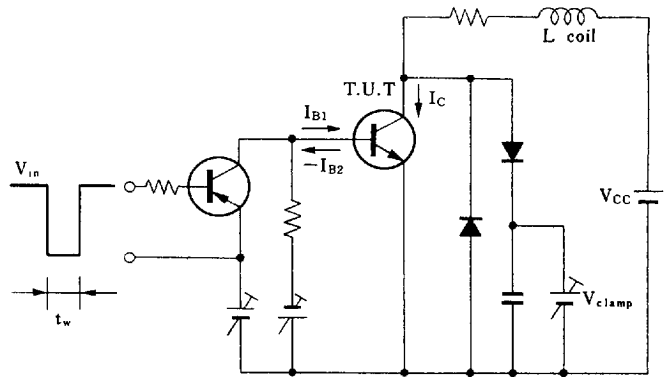

6932852 0016488 455