

MN31121SA

CCD Image Sensor Vertical Driver IC

■ Overview

The MN31121SA is a 2D interline CCD image sensor vertical driver IC that integrates four vertical driver channels and one SUB drive channel on a single chip. This IC can reduce power consumption and the number of external parts.

The MN31121SA consists of a vertical driver block that includes both level shifter circuits and 2-value and 3-value output driver circuits, and a SUB driver block that includes level shifter and 2-value output driver circuits.

■ Features

- Level shifter circuits
Input (V_{DC} , ground) → output (V_{HH} , V_L)
- 2-value output driver circuits (vertical driver block)
Outputs: V_{M24} and V_L
- 3-value output driver circuits (vertical driver block)
Outputs: V_H , V_{M13} , and V_L
- 2-value output driver circuits (SUB driver block)
Outputs: V_{HH} and V_L

■ Applications

- Video cameras, surveillance cameras, digital still cameras, CCD camera systems

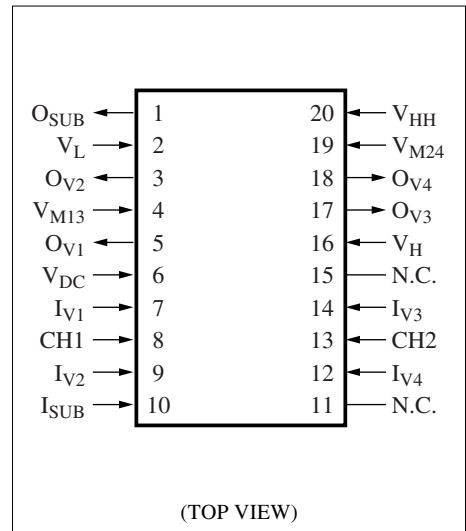

■ Block Diagram

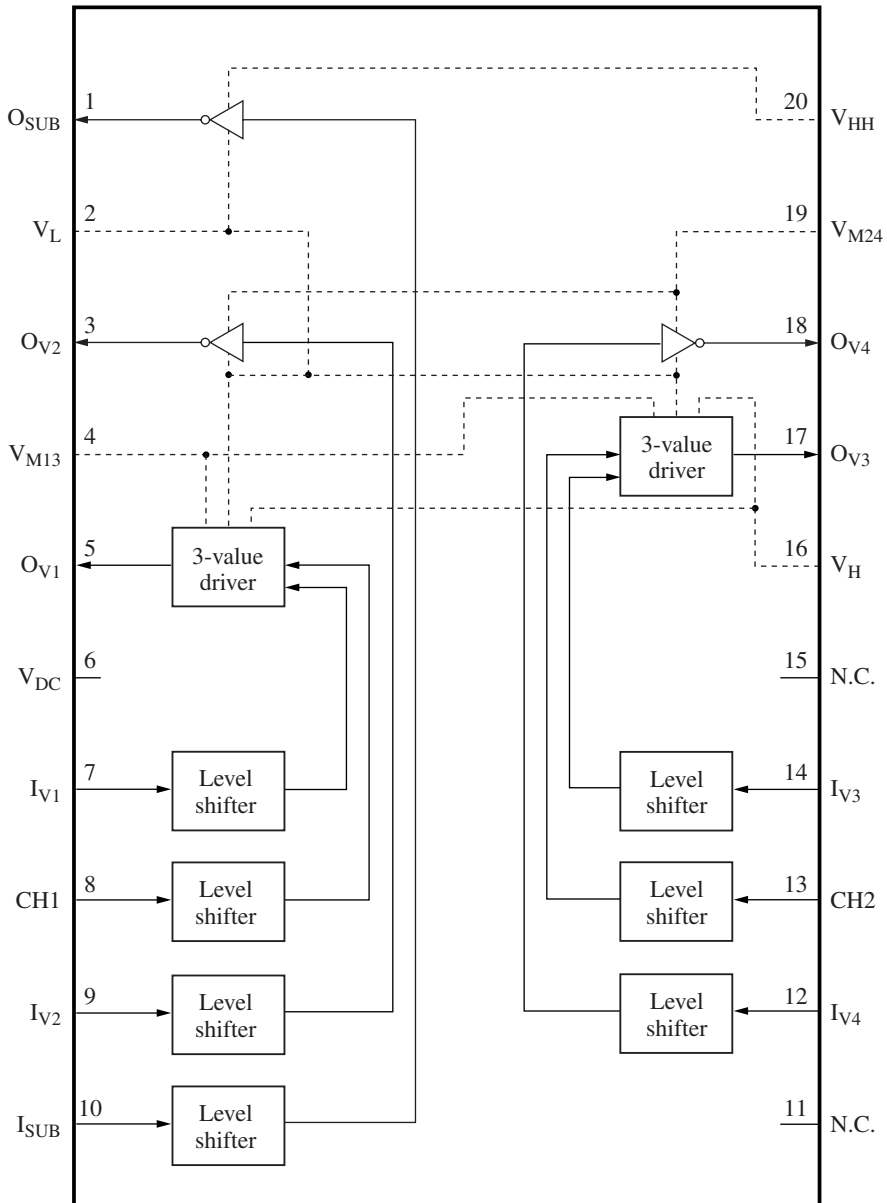

Note) V_{DC}, V_L: Common power supply
 V_{M13}, V_{M24}: Vertical driver block 2-value and 3-value independent power supply
 V_{HH}, V_H: SUB driver block and vertical driver block 3-value independent power supply

■ Pin Descriptions

Pin No.	Pin name	I/O	Description
1	O _{SUB}	O	SUB pulse output
2	V _L	I	Low-level power supply
3	O _{V2}	O	2-value transfer pulse output
4	V _{M13}	I	Mid-level power supply
5	O _{V1}	O	3-value transfer pulse output
6	V _{DC}	I	Input block high-level power supply
7	I _{V1}	I	Transfer pulse input
8	CH1	I	Charge pulse input
9	I _{V2}	I	Transfer pulse input
10	I _{SUB}	I	SUB pulse input
11	N.C.	—	Unused
12	I _{V4}	I	Transfer pulse input
13	CH2	I	Charge pulse input
14	I _{V3}	I	Transfer pulse input
15	N.C.	—	Unused
16	V _H	I	High-level power supply of vertical driver block
17	O _{V3}	O	3-value transfer pulse output
18	O _{V4}	O	2-value transfer pulse output
19	V _{M24}	I	Mid-level power supply
20	V _{HH}	I	High-level power supply of SUB driver block

■ Electrical Characteristics

1. Absolute Maximum Ratings

Parameter	Symbol	Rating	Unit
Supply voltage 1	V _{HH} -V _L	32	V
Supply voltage 2	V _H -V _L	30	V
Supply voltage 3	V _{M13} , V _{M24}	V _L to 6	V
Supply voltage 4	V _{DC}	0 to 7	V
Negative supply voltage	V _L	-12 to 0	V
Input voltage	V _I	V _L - 0.3 to V _{DC} +0.3	V
Input and output clamp diode currents	I _{IC} , I _{OC}	±10	mA
Maximum DC load current	I _{ODC}	±3	mA
Maximum load capacitance	C _L	5 500	pF/PIN
Power dissipation	P _D	180	mW
Operating temperature	T _{opr}	-10 to +70	°C
Storage temperature	T _{stg}	-50 to +125	°C

Note) The absolute maximum ratings are stress ratings only, and do not guarantee operation. Stress in excess of the maximum rating may destroy the device.

■ Electrical Characteristics (continued)

2. Operating Conditions at $T_a = -10^\circ\text{C}$ to $+70^\circ\text{C}$

Parameter	Symbol	Conditions	Min	Typ	Max	Unit
Supply voltage 1	$V_{\text{HH}}-V_{\text{L}}$		$V_{\text{H}}-V_{\text{L}}$	—	30.5	V
Supply voltage 2	$V_{\text{H}}-V_{\text{L}}$		17	—	28	V
Supply voltage 3	$V_{\text{M13}}, V_{\text{M24}}$		-1	—	4	V
Supply voltage 4	$V_{\text{HH}}-V_{\text{M13}}$ $V_{\text{HH}}-V_{\text{M24}}$		12	—	—	V
Supply voltage 5	V_{DC}		2.5	—	3.6	V
Negative supply voltage	V_{L}		-10	—	-4	V
Input frequency	f_{IN}		—	—	20	kHz

3. DC Characteristics at $V_{\text{HH}} = 18.0\text{ V}$, $V_{\text{H}} = 13.0\text{ V}$, $V_{\text{M13}} = V_{\text{M24}} = 1.0\text{ V}$, $V_{\text{L}} = -7.0\text{ V}$, $V_{\text{DC}} = 3.00\text{ V}$, $T_a = -10^\circ\text{C}$ to $+70^\circ\text{C}$

Parameter	Symbol	Conditions	Min	Typ	Max	Unit
Quiescent supply current	I_{DDST}	$V_{\text{I}} = \text{GND}, V_{\text{DC}} = 2.6\text{ V}$	—	—	2	mA
		$V_{\text{I}} = \text{GND}, V_{\text{DC}} = 3.0\text{ V}$	—	—	5	
Operating supply current	I_{DDYN}	Refer to test conditions (Input pulse timing, output load circuit) $V_{\text{I}} = \text{GND}, V_{\text{DC}}$	—	—	7	mA

Input Pins $I_{\text{V1}}, I_{\text{V2}}, I_{\text{V3}}, I_{\text{V4}}, \text{CH1}, \text{CH2}, I_{\text{SUB}}$

High-level voltage	V_{IH}	$V_{\text{DC}} = 2.6\text{ V}$	1.75	—	V_{DC}	V
Low-level voltage	V_{IL}		0.0	—	0.15	V
High-level voltage	V_{IH}	$V_{\text{DC}} = 3.0\text{ V}$	2.5	—	V_{DC}	V
Low-level voltage	V_{IL}		0.0	—	0.3	V
Input leakage current	I_{ILK}	$V_{\text{I}} = 0\text{ V}$ to V_{DC}	-1.0	—	+1.0	μA

Output Pins 1 (2-value outputs) $O_{\text{V2}}, O_{\text{V4}}$

Mid-level output voltage	V_{OM1}	$I_{\text{OM1}} = -1\text{ mA}$	0.9	—	V_{M24}	V
Low-level output voltage	V_{OL1}	$I_{\text{OL1}} = 1\text{ mA}$	V_{L}	—	-6.9	V
Output on resistance (mid level)	R_{ONM1}	$I_{\text{OM1}} = -50\text{ mA}$	—	—	60	Ω
Output on resistance (low level)	R_{ONL1}	$I_{\text{OL1}} = 50\text{ mA}$	—	—	40	Ω

Output Pins 2 (3-value outputs) $O_{\text{V1}}, O_{\text{V3}}$

High-level output voltage	V_{OH2}	$I_{\text{OH2}} = -1\text{ mA}$	12.9	—	V_{H}	V
Mid-level output voltage	V_{OM2}	$I_{\text{OM2}} = -1\text{ mA}$	0.9	—	V_{M13}	V
Low-level output voltage	V_{OL2}	$I_{\text{OL2}} = 1\text{ mA}$	V_{L}	—	-6.9	V
Output on resistance (high level)	R_{ONH2}	$I_{\text{OH2}} = -50\text{ mA}$	—	—	70	Ω
Output on resistance (mid level)	R_{ONM2}	$I_{\text{OM2}} = \pm 50\text{ mA}$	—	—	60	Ω
Output on resistance (low level)	R_{ONL2}	$I_{\text{OL2}} = 50\text{ mA}$	—	—	60	Ω

Output Pins 3 (SUB outputs) O_{SUB}

High-level output voltage	V_{OHH3}	$I_{\text{OHH3}} = -1\text{ mA}$	17.9	—	V_{HH}	V
Low-level output voltage	V_{OL3}	$I_{\text{OL3}} = 1\text{ mA}$	V_{L}	—	-6.9	V

■ Electrical Characteristics (continued)

3. DC Characteristics (continued) at $V_{HH} = 18.0\text{ V}$, $V_H = 13.0\text{ V}$, $V_{M13} = V_{M24} = 1.0\text{ V}$, $V_L = -7.0\text{ V}$, $V_{DC} = 3.00\text{ V}$, $T_a = -10^\circ\text{C}$ to $+70^\circ\text{C}$

Parameter	Symbol	Conditions	Min	Typ	Max	Unit
Output Pins 3 (SUB outputs) (continued)		O_{SUB}				
Output on resistance (high level)	R_{ONHH3}	$I_{ONHH3} = -50\text{ mA}$	—	—	60	Ω
Output on resistance (low level)	R_{ONL3}	$I_{ONL3} = 50\text{ mA}$	—	—	50	Ω

4. AC Characteristics at $V_{HH} = 18.0\text{ V}$, $V_H = 13.0\text{ V}$, $V_{M13} = V_{M24} = 1.0\text{ V}$, $V_L = -7.0\text{ V}$, $V_{DC} = 3.00\text{ V}$, $T_a = -10^\circ\text{C}$ to $+70^\circ\text{C}$

Parameter	Symbol	Conditions	Min	Typ	Max	Unit
Output Pins 1 (2-value outputs)		O_{V2}, O_{V4}				
Propagation delay time	T_{PLM} T_{PML}	No load, Low level to mid level	—	150	250	ns
Rise time Fall time	T_{TLM} T_{TML}	Refer to test conditions (Output load circuit)	—	300	400	ns
Output Pins 2 (3-value outputs)		O_{V1}, O_{V3}				
Propagation delay time	T_{PLM} T_{PML}	No load, Low level to mid level	—	150	250	ns
Propagation delay time	T_{PMH} T_{PHM}	No load, Mid level to high level	—	200	400	ns
Rise time Fall time	T_{TLM} T_{TML}	Refer to test conditions (Output load circuit)	—	300	400	ns
Rise time Fall time	T_{TMH} T_{THM}	Refer to test conditions (Output load circuit)	—	350	550	ns
Output Pins 3 (SUB output)		O_{SUB}				
Propagation delay time	T_{PLHH} T_{PHHL}	No load, Low level to high level	—	150	250	ns
Rise time Fall time	T_{TLHH} T_{THHL}	Refer to test conditions (Output load circuit)	—	300	400	ns

■ Test Conditions

1. Output Load Circuit

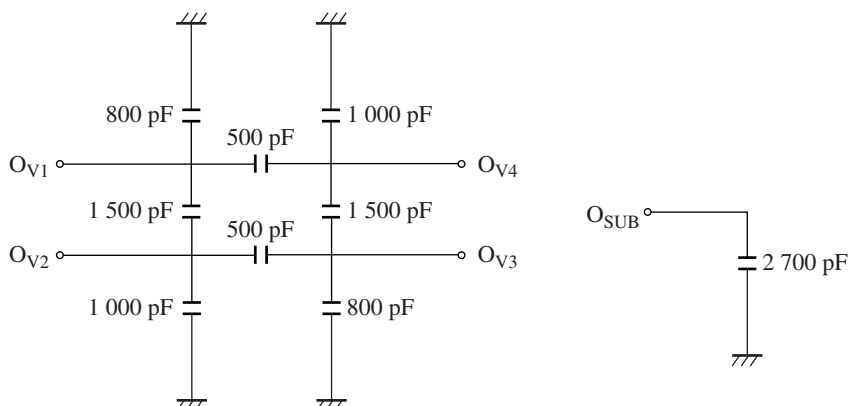

■ Test Conditions (continued)

2. Input Pulse Timing Charts (NTSC)

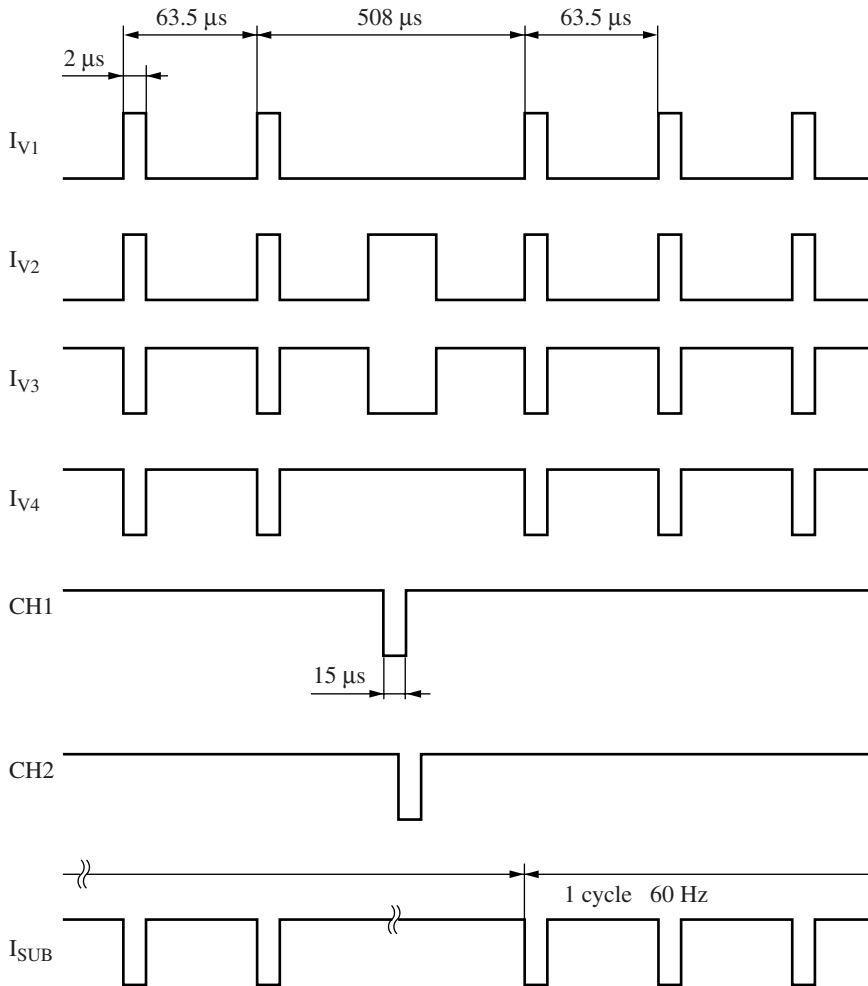

■ Function Tables

1. 2-Value Transfer Pulse (vertical driver block)

I _{V2} I _{V4}	O _{V2} O _{V4}
High	Low
Low	Mid

2. 3-Value Transfer Pulse

CH1 CH2	I _{V1} I _{V3}	O _{V1} O _{V3}
High	High	Low
	Low	Mid
Low	High	Low
	Low	High

Note) I_{V1}, I_{V2}, I_{V3}, I_{V4}, CH1, CH2

High: V_{DC}, Low: Ground

O_{V1}, O_{V2}, O_{V3}, O_{V4}

High: V_H, Mid: V_{M13} or V_{M24}, Low: V_L

■ Function Tables (continued)

3. Unnecessary Charge Sweep-Out Pulse (SUB driver block)

I_{SUB}	O_{SUB}
High	Low
Low	High

Note) I_{SUB}

High: V_{DC} , Low: Ground

O_{SUB}

High: V_{HH} , Low: V_L

■ Timing Charts

1. 2-value transfer pulse

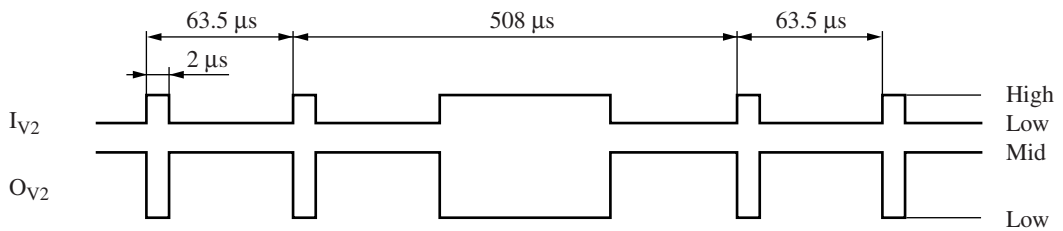

2. 2-value transfer pulse

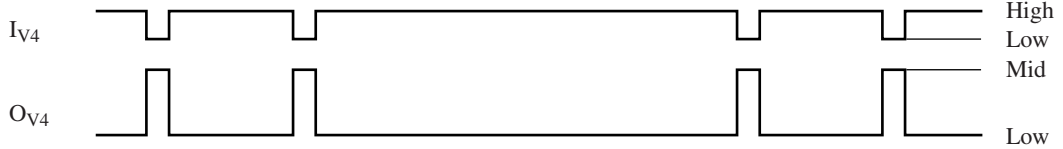

3. 3-value transfer pulse

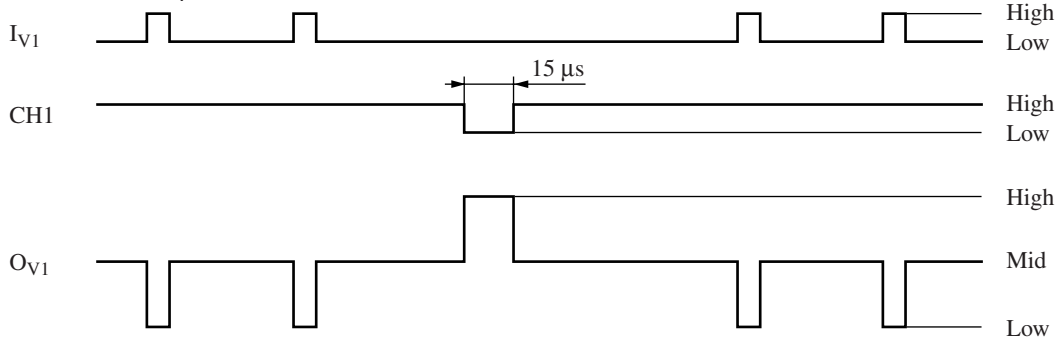

4. 3-value transfer pulse

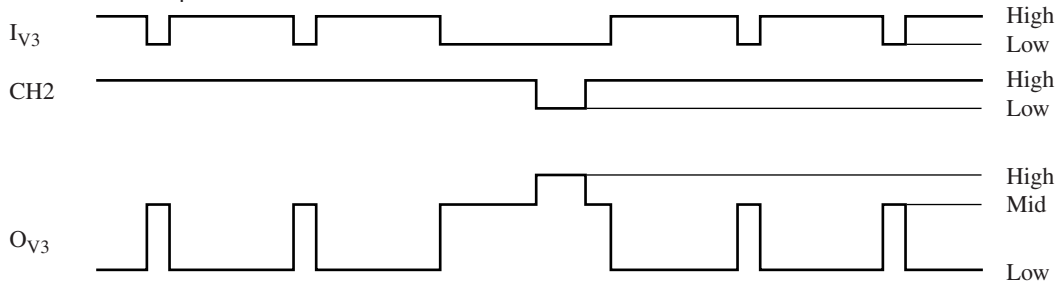

■ Timing Charts (continued)

5. SUB pulse

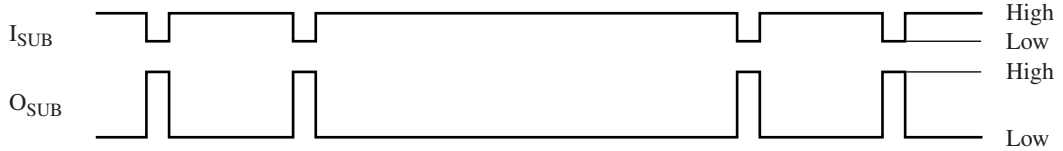

■ Usage Notes

1. If the SUB driver is not used:
 - 1) Connect V_{HH} (pin 20) to V_H (pin 16).
 - 2) Connect I_{SUB} (pin 10) to V_{DC} (pin 6).
 - 3) Leave O_{SUB} (pin 1) open.
2. Mount the bypass capacitors for power supply pins V_{HH} (pin 20), V_H (pin 16), V_{M13} (pin 4), V_{M24} (pin 19), V_L (pin 2), and V_{DC} (pin 6) as close as possible to the pin itself.
3. If the overcurrents that occur at power on and power off are limited to under 10 ms and under 100 mA, then the MN31121SA is guaranteed for 10,000 power cycle (power on/power off) operations.
4. Guarantee period after packing is opened
The guarantee period after opening the moisture-proof packing is three weeks under environmental conditions of 30°C and 70% RH.
5. The recommended reflow soldering temperature is 230°C.

■ Application Circuit Example

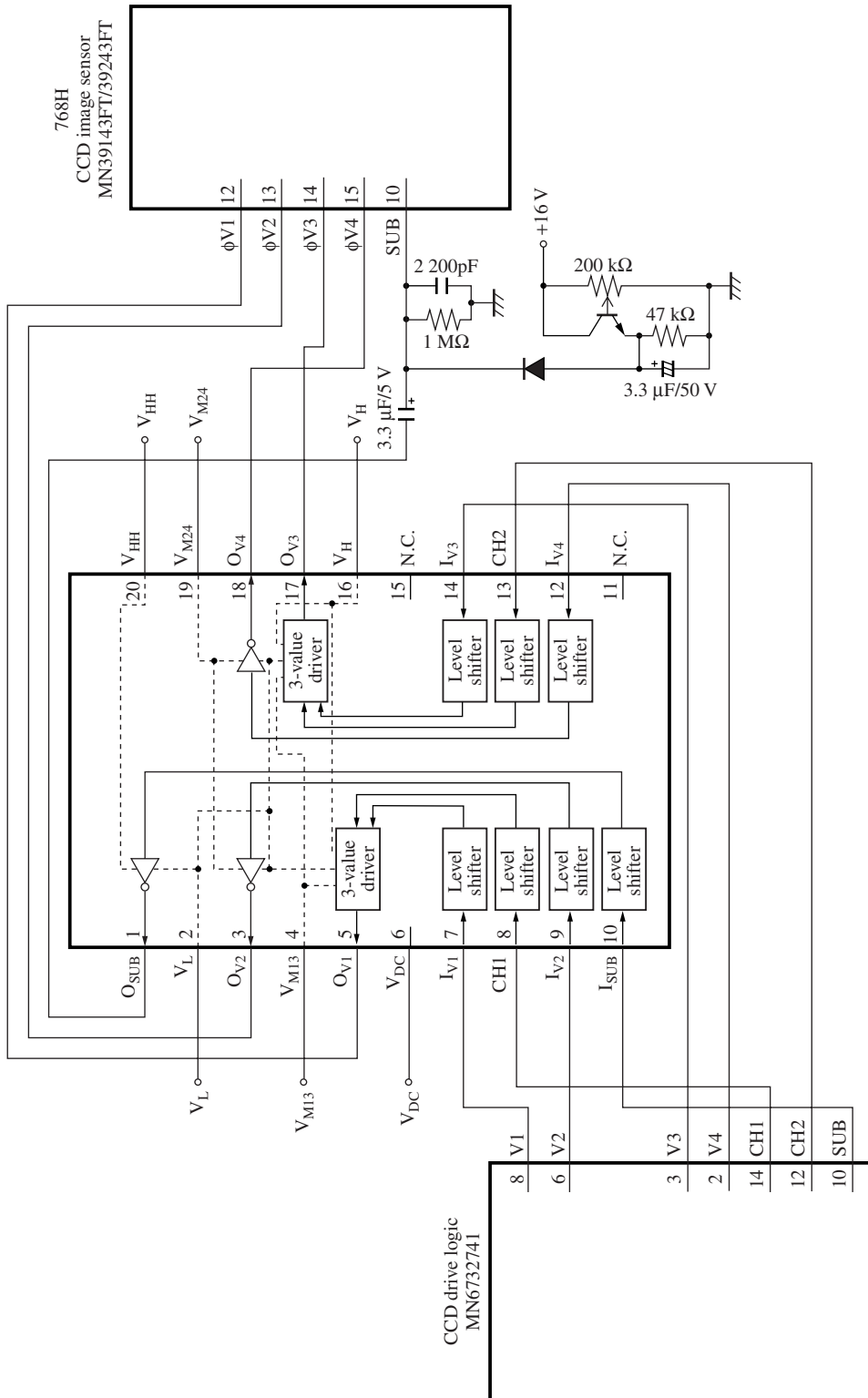

Note) Mount the bypass capacitors for the MN31121SA power supply pins (V_{HH}, V_H, V_{M13}, V_{M24}, V_L, and V_{DC}) as close as possible to the pin itself.

■ Package Dimensions (Unit: mm)

- SSOP020-P-0225

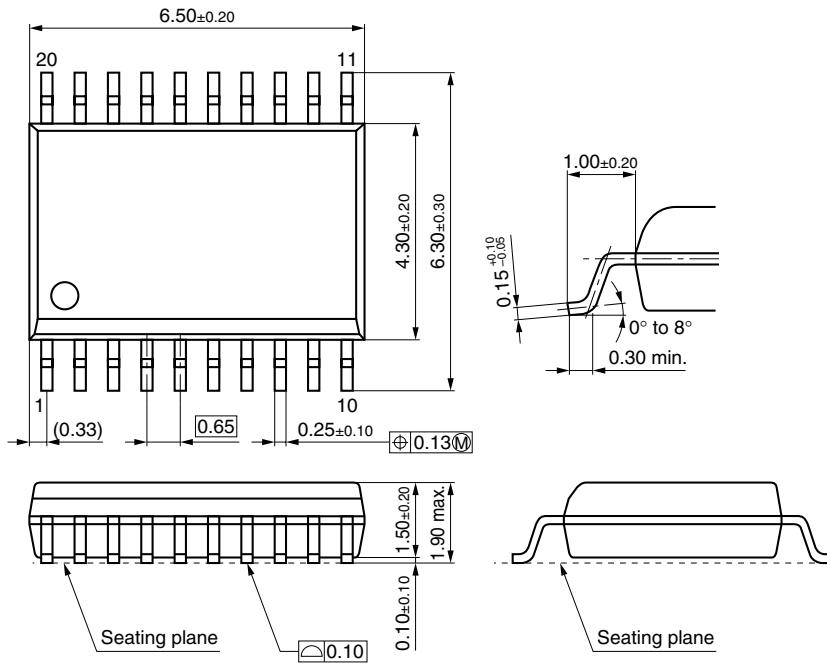

Note) The package of this product will be changed to the following lead-free type (SSOP020-P-0225C).

■ New Package Dimensions (Unit: mm)

- SSOP020-P-0225C (Lead-free package)

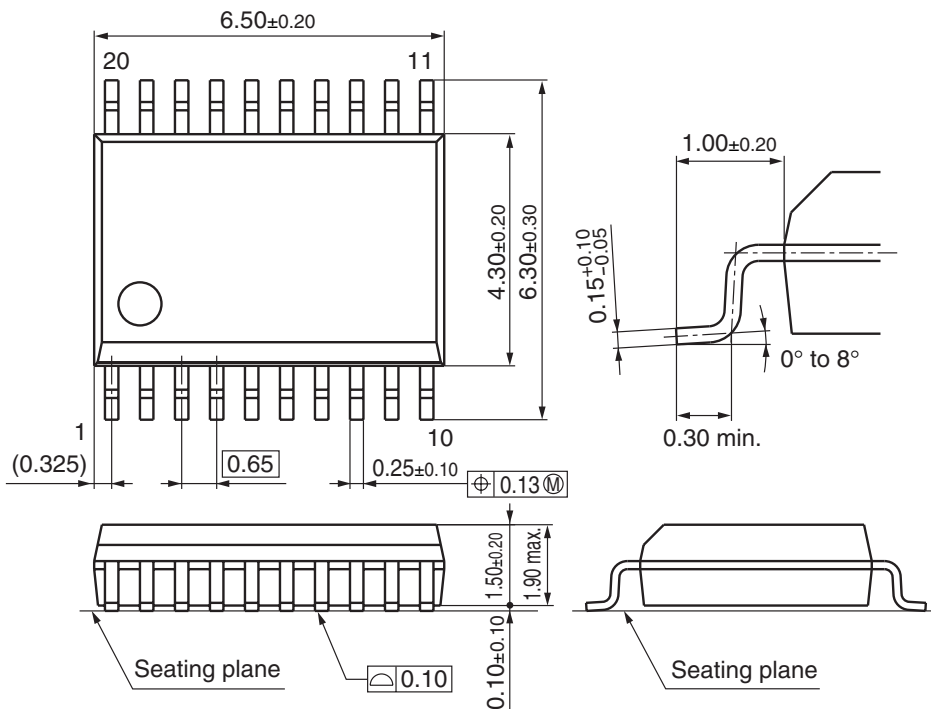

Request for your special attention and precautions in using the technical information and semiconductors described in this material

- (1) An export permit needs to be obtained from the competent authorities of the Japanese Government if any of the products or technologies described in this material and controlled under the "Foreign Exchange and Foreign Trade Law" is to be exported or taken out of Japan.
- (2) The technical information described in this material is limited to showing representative characteristics and applied circuit examples of the products. It does not constitute the warranting of industrial property, the granting of relative rights, or the granting of any license.
- (3) The products described in this material are intended to be used for standard applications or general electronic equipment (such as office equipment, communications equipment, measuring instruments and household appliances).
Consult our sales staff in advance for information on the following applications:
 - Special applications (such as for airplanes, aerospace, automobiles, traffic control equipment, combustion equipment, life support systems and safety devices) in which exceptional quality and reliability are required, or if the failure or malfunction of the products may directly jeopardize life or harm the human body.
 - Any applications other than the standard applications intended.
- (4) The products and product specifications described in this material are subject to change without notice for reasons of modification and/or improvement. At the final stage of your design, purchasing, or use of the products, therefore, ask for the most up-to-date Product Standards in advance to make sure that the latest specifications satisfy your requirements.
- (5) When designing your equipment, comply with the guaranteed values, in particular those of maximum rating, the range of operating power supply voltage and heat radiation characteristics. Otherwise, we will not be liable for any defect which may arise later in your equipment.
Even when the products are used within the guaranteed values, redundant design is recommended, so that such equipment may not violate relevant laws or regulations because of the function of our products.
- (6) When using products for which dry packing is required, observe the conditions (including shelf life and after-unpacking standby time) agreed upon when specification sheets are individually exchanged.
- (7) No part of this material may be reprinted or reproduced by any means without written permission from our company.

Please read the following notes before using the datasheets

- A. These materials are intended as a reference to assist customers with the selection of Panasonic semiconductor products best suited to their applications.
Due to modification or other reasons, any information contained in this material, such as available product types, technical data, and so on, is subject to change without notice.
Customers are advised to contact our semiconductor sales office and obtain the latest information before starting precise technical research and/or purchasing activities.
- B. Panasonic is endeavoring to continually improve the quality and reliability of these materials but there is always the possibility that further rectifications will be required in the future. Therefore, Panasonic will not assume any liability for any damages arising from any errors etc. that may appear in this material.
- C. These materials are solely intended for a customer's individual use.
Therefore, without the prior written approval of Panasonic, any other use such as reproducing, selling, or distributing this material to a third party, via the Internet or in any other way, is prohibited.