

MN12511

Fluorescent Display Tube Driver LSI

■ Overview

The MN12511 is a fluorescent display tube driver LSI. It accepts data for display transferred over a serial interface, generates the digit and/or segment drive signals, and outputs those signals from 16 high-voltage ports.

This LSI allows the number of digits displayed to be increased easily by the cascade connection of additional MN12511 LSIs. Also, the MN12511 does not preassign the outputs to digits or segments, so it can be used with a wide range of display types.

■ Features

- Sixteen high-voltage handling output ports
 - Number of digit outputs (DGT): 1 to 15 outputs can be arbitrarily assigned
 - Number of segment outputs (SEG): 1 to 15 outputs can be arbitrarily assigned
- FLP display
 - The display mode can be set to any combination of from 1 DGT × 15 SEG to 15 DGT × 1 SEG
 - The display on/off state can be controlled from the OE pin.
- Four-wire serial interface (Includes a chip select signal)
 - Built-in shift register
 - The MN12511 can be connected in cascade.
- Supply voltage
 - Digital block (V_{DD}): +4.5 to 5.5 V
 - High-voltage (V_{pp}): $V_{DD} - 35$ V

■ Applications

- Video, audio, and other equipment that uses fluorescent display tubes

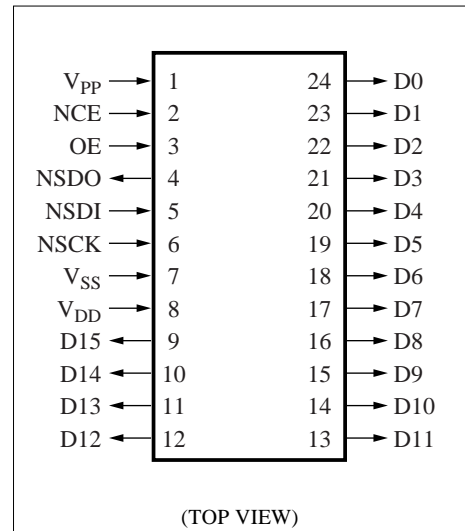

■ Block Diagram

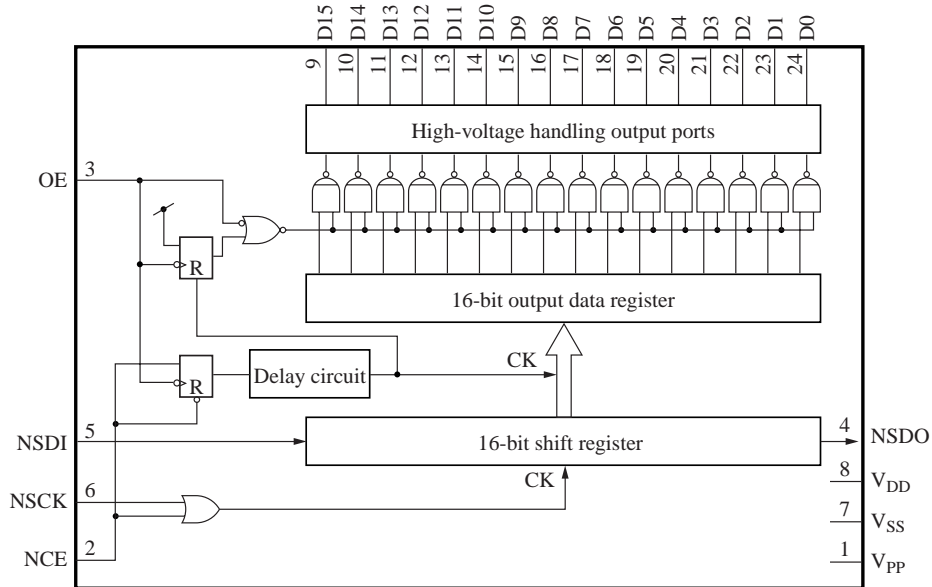

■ Pin Descriptions

Pin No.	Symbol	I/O	Description
1	V _{PP}	I	Pull-down power supply
2	NCE	I	Chip select input
3	OE	I	Display on/off state control input
4	NSDO	O	Serial data output
5	NSDI	I	Serial data input
6	NSCK	I	Serial data clock input
7	V _{SS}	I	Ground (display)
8	V _{DD}	I	Power supply
9	D15	O	High-voltage output 15
10	D14	O	High-voltage output 14
11	D13	O	High-voltage output 13
12	D12	O	High-voltage output 12
13	D11	O	High-voltage output 11
14	D10	O	High-voltage output 10
15	D9	O	High-voltage output 9
16	D8	O	High-voltage output 8
17	D7	O	High-voltage output 7
18	D6	O	High-voltage output 6

■ Pin Descriptions (continued)

Pin No.	Symbol	I/O	Description
19	D5	O	High-voltage output 5
20	D4	O	High-voltage output 4
21	D3	O	High-voltage output 3
22	D2	O	High-voltage output 2
23	D1	O	High-voltage output 1
24	D0	O	High-voltage output 0

■ Operational Description

• Transfer timing

The figure below shows the input timing for the NCE, NSCK, and NSDI pins during data transfers.

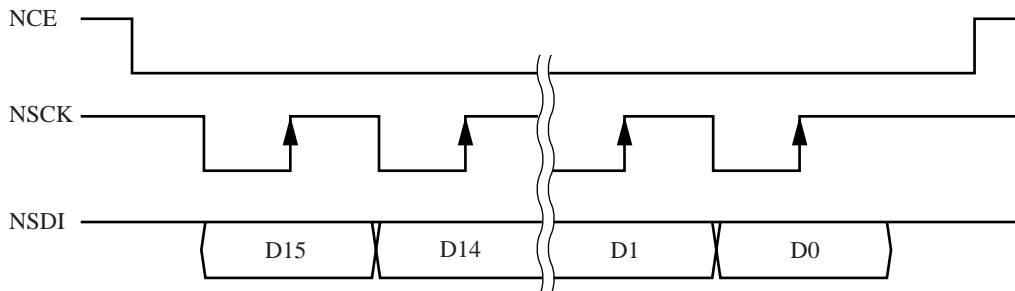

NSDI is acquired on the rising edge of NSCK.
NSDO is output on the falling edge of NSCK.

• Transfer Format

The following transfer formats could be considered as the data format for data transfer from the system microcontroller.

Note that other transfer formats are possible, depending on the requirements of the particular application.

Example: For use with a 6-grid × 10-segment display (Using a single MN12511)

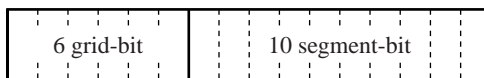

Example: For use with a 15-grid × 11-segment display (Using two MN12511 chips)



Note) *: Bits marked with an asterisk are unused.

■ Operational Description (continued)

• Display Timing

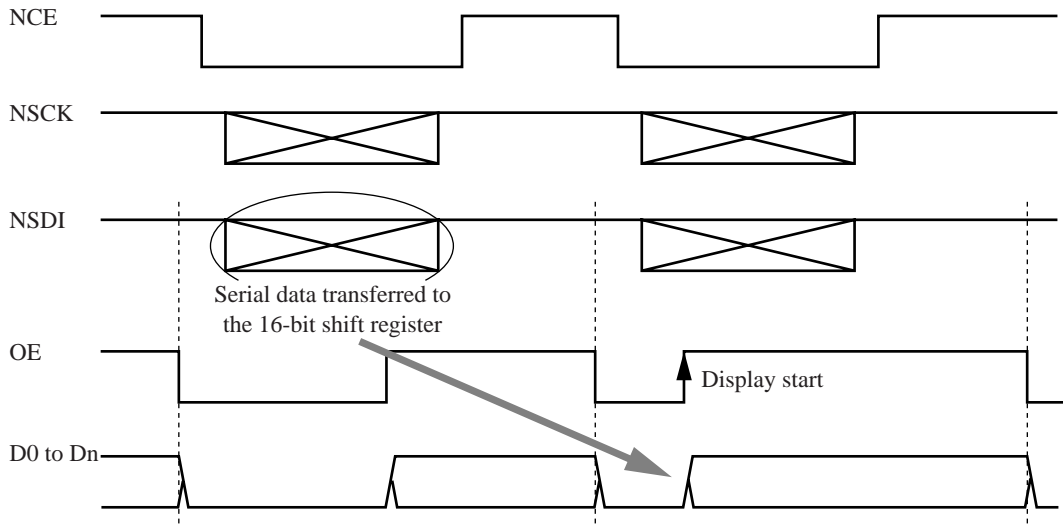

- Note) 1. The OE pin should be set low each time the display is changed.
 2. If the fluorescent display control input (OE) is set low during a serial data transfer, the MN12511 will detect an incorrect transfer and output the V_{PP} level from all the high-voltage output ports.

■ Electrical Characteristics

1. Absolute Maximum Ratings at $V_{SS} = 0\text{ V}$, $T_a = 25\text{ }^\circ\text{C} \pm 2\text{ }^\circ\text{C}$

Parameter	Symbol	Rating	Unit
Supply voltage (digital power supply)	V_{DD}	- 0.3 to +7.0	V
Supply voltage (High-voltage output power supply)	V_{PP}	$V_{DD} - 45$ to $V_{DD} + 0.3$	V
Input voltage	V_{I1}	$V_{SS} - 0.3$ to $V_{DD} + 0.3$	V
Output voltage	V_{O1}	$V_{SS} - 0.3$ to $V_{DD} + 0.3$	V
I/O voltage	V_{IO1}	$V_{SS} - 0.3$ to $V_{DD} + 0.3$	V
High-voltage output pin voltage	V_{IO2}	- 40 to $V_{DD} + 0.3$	V
Normal pin peak output current	IOH(peak)	-10	mA
	IOL(peak)	30	
Normal pin average output current	IOH(ave)	-5	mA
	IOL(ave)	15	
High-voltage output pin output current	IOH	-30	mA
Allowable power dissipation	PT	300	mW
Operating temperature	T_{opr}	-10 to +70	$^\circ\text{C}$
Storage temperature	T_{stg}	-55 to +125	$^\circ\text{C}$

- Note) 1. These values are limiting values under which the device will not be destroyed. Operation is not guaranteed within these ranges.
 2. These values are limiting values such that the device will not be destroyed if voltages within these ranges are applied to the pins. Operation is not guaranteed within these ranges.
 3. Applies to any 100 ms period.

■ Electrical Characteristics (continued)

Note) (continued)

- The rating for capacitance coupled spike noise that exceeds the absolute maximum rating of -40 V and that occurs at most once in any of the display cycles is defined as shown below.

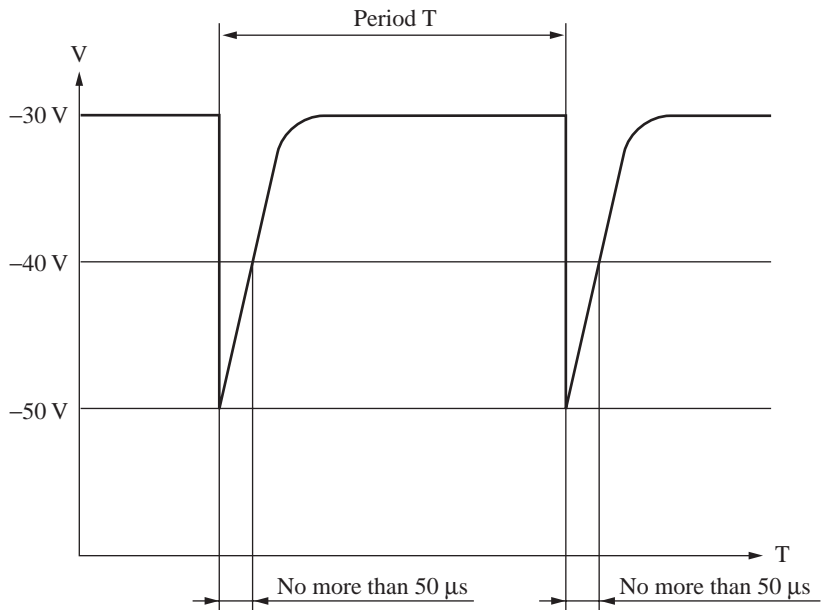

- Insert a capacitor of at least $0.1\ \mu\text{F}$ between V_{DD} and V_{SS} as close as possible to the LSI pins.

2. Operating Conditions at $V_{SS} = 0\text{ V}$, $T_a = -10\text{ }^\circ\text{C}$ to $70\text{ }^\circ\text{C}$

Parameter	Symbol	Conditions	Min	Typ	Max	Unit
Supply Voltage	V_{DD}		4.5	5.0	5.5	V
	V_{PP}	Potential difference between V_{DD} and V_{PP} .	—	—	35	

3. DC Characteristics at $V_{SS} = 0\text{ V}$, $T_a = -10\text{ }^\circ\text{C}$ to $70\text{ }^\circ\text{C}$

Parameter	Symbol	Conditions	Min	Typ	Max	Unit
1) Supply current						
Operating supply current	I_{DD}		—	3	10	mA
2) Input pins NCE, OE, NSCK, and NSDI (Schmitt inputs)						
High-level input voltage	V_{IH1}		$0.7V_{DD}$	—	V_{DD}	V
Low-level input voltage	V_{IL1}		V_{SS}	—	$0.2V_{DD}$	V
Input leakage current	$ILK1$	$V_{IN} = 0\text{ to }5\text{ V}$	—	—	± 10	μA
3) The NSDO output pin						
High-level output voltage	$VOH1$	$IOH1 = -0.5\text{ mA}$	4.5	—	—	V
Low-level output voltage	$VOL1$	$IOL2 = 0.5\text{ mA}$	—	—	0.5	V

■ Electrical Characteristics (continued)

3. DC Characteristics at $V_{SS} = 0\text{ V}$, $T_a = -10\text{ °C}$ to 70 °C (continued)

Parameter	Symbol	Conditions	Min	Typ	Max	Unit
4) High-voltage output pins D15 to 0 (P-channel open drain, built-in pull-down resistors)						
Output current	IOH2	$V_{DD} = 5\text{ V}$, $V_{PP} = -30\text{ V}$, $VOH2 = 3.1\text{ V}$	-8	—	—	mA
		$V_{DD} = 5\text{ V}$, $V_{PP} = -30\text{ V}$, $VOH2 = 2.0\text{ V}$	-1.5	—	—	
Output leakage current	ILOL2	$V_{DD} = 5\text{ V}$, $V_{PP} = -30\text{ V}$, $VOH2 = -30\text{ V}$, P ch.-Tr. OFF	—	—	± 10	μA
Pull-down resistor	RINT2	$V_{DD} = 5\text{ V}$, $V_{PP} = -30\text{ V}$, $VOH2 = 5\text{ V}$	30	—	250	k Ω
		$V_{DD} = 5\text{ V}$, $V_{PP} = -30\text{ V}$, $VOH2 = -15\text{ V}$	30	—	250	

4. AC Characteristics at $V_{SS} = 0\text{ V}$, $T_a = -10\text{ °C}$ to 70 °C

Parameter	Symbol	Conditions	Min	Typ	Max	Unit
Serial clock frequency (NSCK)	f_{NSCK}	Figure 1	—	—	1	MHz
NCE interval (OE → NCE)	T_{OE}	Figure 1	100	—	—	ns
NSCK interval (NCE → NSCK)	T_{NCE}	Figure 1	100	—	—	ns
Serial input setup time (NSDI)	T_{NSDIS}	Figure 2	100	—	—	ns
Serial input hold time (NSDI)	T_{NSDIH}	Figure 2	100	—	—	ns
Serial output delay time (NSDO)	T_{NSDOD}	Figure 2	—	—	100	ns

■ Electrical Characteristics (continued)

4. AC Characteristics at $V_{SS} = 0\text{ V}$, $T_a = -10\text{ }^\circ\text{C}$ to $70\text{ }^\circ\text{C}$ (continued)

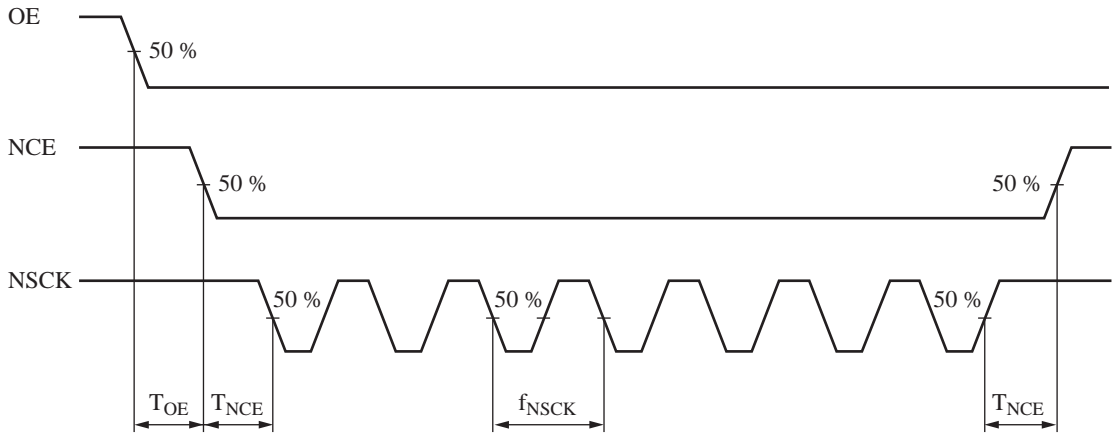

Figure 1 OE, NCE, and NSCK Timing

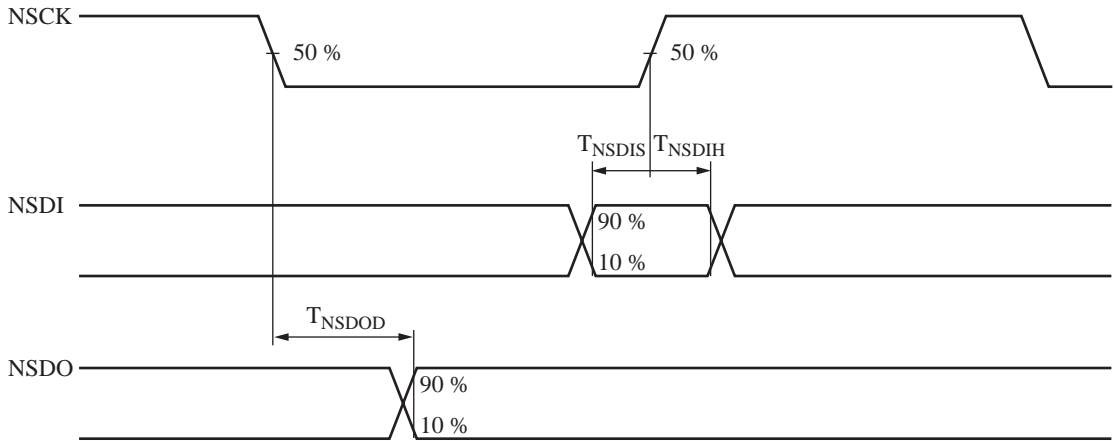
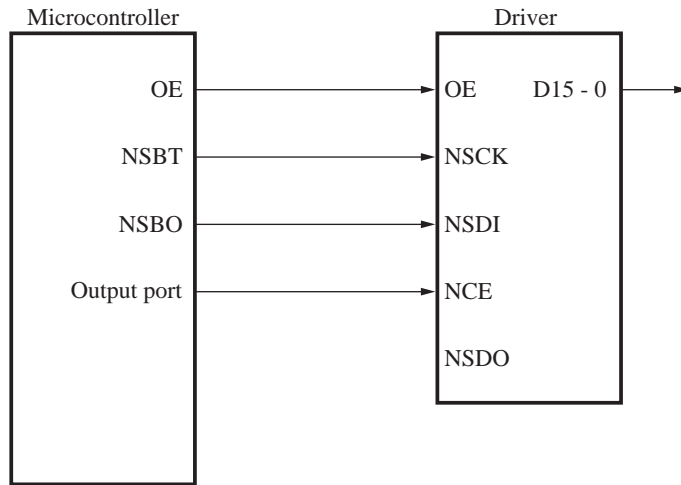

Figure 2 NSCK, NSDI, and NSDO Timing

■ Sample Application Systems

- When one driver LSI is used



- When two driver LSIs are used

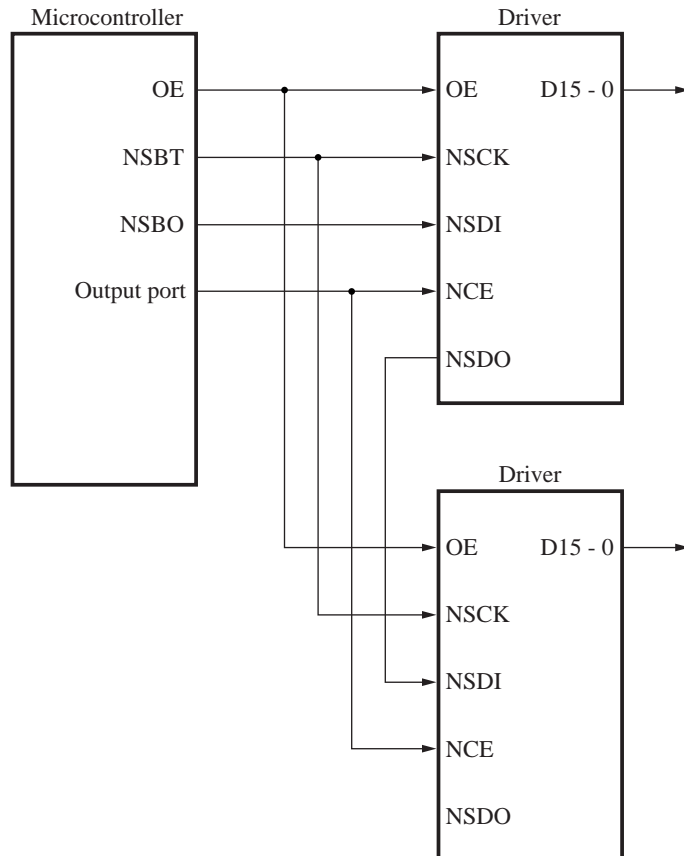

■ Package Dimensions (Unit : mm)

- SOP024-P-0375

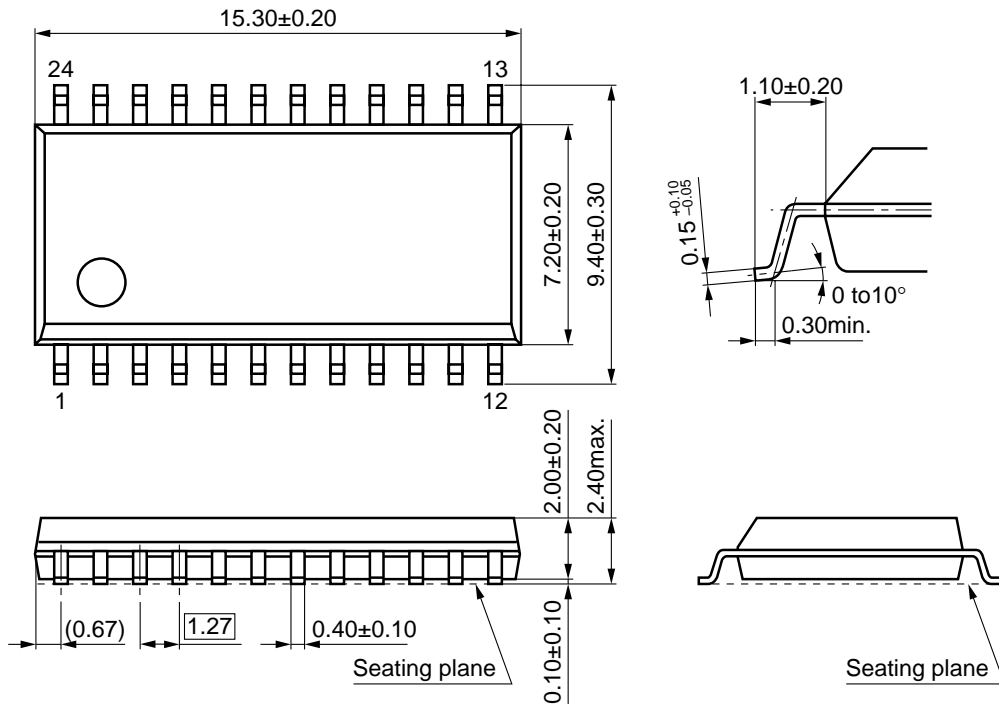

Request for your special attention and precautions in using the technical information and semiconductors described in this material

- (1) An export permit needs to be obtained from the competent authorities of the Japanese Government if any of the products or technologies described in this material and controlled under the "Foreign Exchange and Foreign Trade Law" is to be exported or taken out of Japan.
- (2) The technical information described in this material is limited to showing representative characteristics and applied circuit examples of the products. It does not constitute the warranting of industrial property, the granting of relative rights, or the granting of any license.
- (3) The products described in this material are intended to be used for standard applications or general electronic equipment (such as office equipment, communications equipment, measuring instruments and household appliances).
Consult our sales staff in advance for information on the following applications:
 - Special applications (such as for airplanes, aerospace, automobiles, traffic control equipment, combustion equipment, life support systems and safety devices) in which exceptional quality and reliability are required, or if the failure or malfunction of the products may directly jeopardize life or harm the human body.
 - Any applications other than the standard applications intended.
- (4) The products and product specifications described in this material are subject to change without notice for reasons of modification and/or improvement. At the final stage of your design, purchasing, or use of the products, therefore, ask for the most up-to-date Product Standards in advance to make sure that the latest specifications satisfy your requirements.
- (5) When designing your equipment, comply with the guaranteed values, in particular those of maximum rating, the range of operating power supply voltage and heat radiation characteristics. Otherwise, we will not be liable for any defect which may arise later in your equipment.
Even when the products are used within the guaranteed values, redundant design is recommended, so that such equipment may not violate relevant laws or regulations because of the function of our products.
- (6) When using products for which dry packing is required, observe the conditions (including shelf life and after-unpacking standby time) agreed upon when specification sheets are individually exchanged.
- (7) No part of this material may be reprinted or reproduced by any means without written permission from our company.

Please read the following notes before using the datasheets

- A. These materials are intended as a reference to assist customers with the selection of Panasonic semiconductor products best suited to their applications.
Due to modification or other reasons, any information contained in this material, such as available product types, technical data, and so on, is subject to change without notice.
Customers are advised to contact our semiconductor sales office and obtain the latest information before starting precise technical research and/or purchasing activities.
- B. Panasonic is endeavoring to continually improve the quality and reliability of these materials but there is always the possibility that further rectifications will be required in the future. Therefore, Panasonic will not assume any liability for any damages arising from any errors etc. that may appear in this material.
- C. These materials are solely intended for a customer's individual use.
Therefore, without the prior written approval of Panasonic, any other use such as reproducing, selling, or distributing this material to a third party, via the Internet or in any other way, is prohibited.