HN27C4096HG/HCC Series

262,144-word × 16-bit CMOS UV Erasable and Programmable
ROM

HITACHI

Description

HN27C4096HG/HCC is a 4-Mbit ultraviolet erasable and electrically programmable ROM, featuring high speed and low power dissipation. Fabricated on advanced fine process and high speed circuitry technique, the HN27C4096HG/HCC makes high speed sub 100 ns access time possible. Therefore, it is suitable for fast 16-bit and 32-bit microcomputer systems using high speed microcomputer such as the 80286/80386 and 68020/68030. The HN27C4096HG/HCC offers high speed programming using page programming mode. This device has the package variation of cerdip 40-pin and JLCC 44-pin.

Features

- High speed
 - Access time: 85 ns (max)
- Low power dissipation
 - Active mode: 35 mW/MHz (typ)
- Fast high reliability page programming and fast high-reliability programming
 - Programming voltage: +12.5 V D.C.
 - Programming time: 3.5 sec. (min) (Theoretical in page programming)
- Inputs and outputs TTL compatible during both read and program modes.
- Pin arrangement: 40-pin JEDEC standard, 44-pin JLCC JEDEC standard
- Device identifier mode: Manufacturer code and device code

Ordering Information

Type No.	Access Time	Package
HN27C4096HG-85	85 ns	600-mil 40-pin Cerdip (DG-40A)
HN27C4906HCC-85	85 ns	44-pin J-bend leaded chip carrier (CC-44)

HN27C4096HG/HCC Series

Pin Arrangement

HN27C4096HG Series

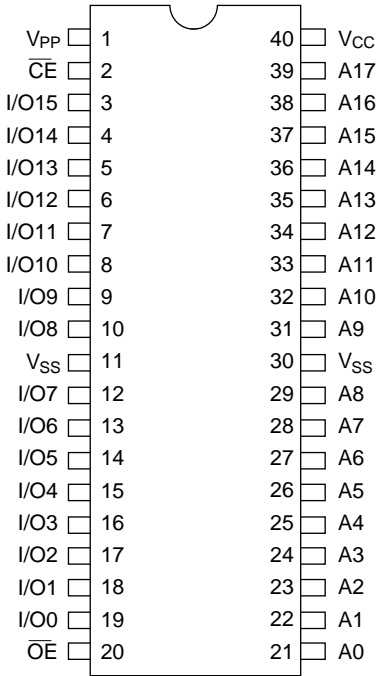

(Top View)

HN27C4096HCC Series

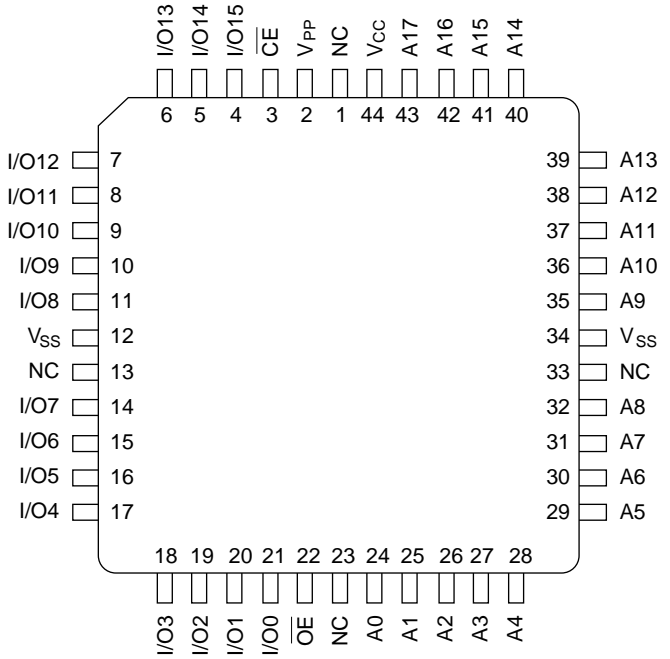

(Top View)

Pin Description

Pin Name	Function
A0 – A17	Address
I/O0 – I/O15	Input/output
$\overline{\text{CE}}$	Chip enable
$\overline{\text{OE}}$	Output enable
V _{CC}	Power supply
V _{PP}	Programming power supply
V _{SS}	Ground

Block Diagram

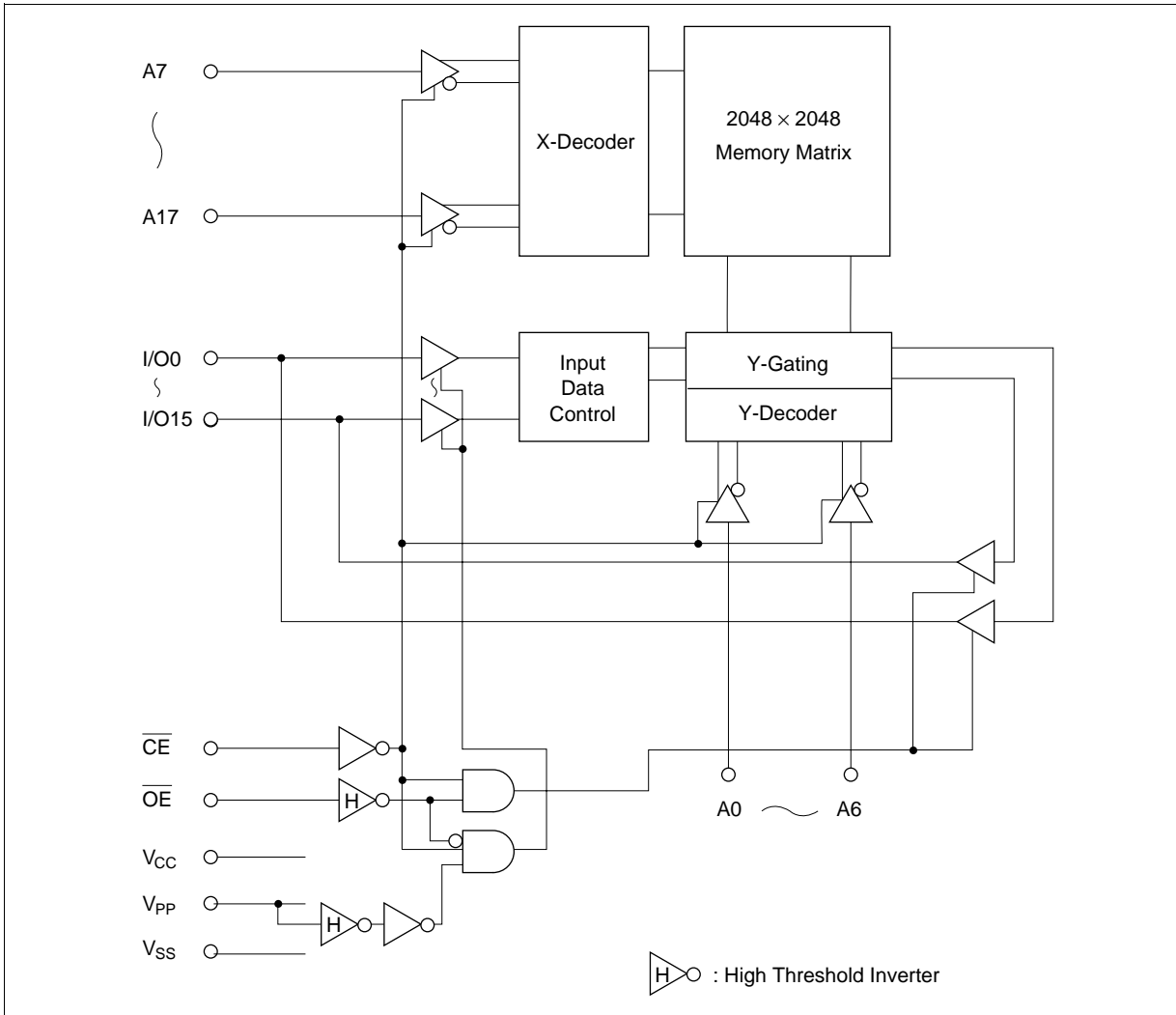

Mode Selection

		Pin	\overline{CE}	\overline{OE}	A9	V_{PP}	V_{CC}	I/O
		CC	(3)	(22)	(35)	(2)	(44)	(4 – 11, 14 – 21)
Mode		G	(2)	(20)	(31)	(1)	(40)	(3 – 10, 12 – 19)
Read			V_{IL}	V_{IL}	X	$V_{SS} - V_{CC}$	V_{CC}	Dout
Output disable			V_{IL}	V_{IH}	X	$V_{SS} - V_{CC}$	V_{CC}	High-Z
Standby			V_{IH}	X	X	$V_{SS} - V_{CC}$	V_{CC}	High-Z
Page prog.	Page program set		V_{IH}	V_H^{*2}	X	V_{PP}	V_{CC}	High-Z
	Page data latch		V_{IL}	V_H^{*2}	X	V_{PP}	V_{CC}	Din
	Page program		V_{IL}	V_{IH}	X	V_{PP}	V_{CC}	High-Z
	Page program verify		V_{IH}	V_{IL}	X	V_{PP}	V_{CC}	Dout
	Page program reset		V_{IH}	V_{IH}	X	V_{CC}	V_{CC}	High-Z
Word prog.	Program		V_{IL}	V_{IH}	X	V_{PP}	V_{CC}	Din
	Program verify		V_{IH}	V_{IL}	X	V_{PP}	V_{CC}	Dout
	Optional verify		V_{IL}	V_{IL}	X	V_{PP}	V_{CC}	Dout
	Program inhibit		V_{IH}	V_{IH}	X	V_{PP}	V_{CC}	High-Z
Identifier			V_{IL}	V_{IL}	V_H^{*2}	$V_{SS} - V_{CC}$	V_{CC}	Code

Notes: 1. X: Don't care.

2. V_H : 12.0 V \pm 0.5 V

Absolute Maximum Ratings

Parameter	Symbol	Value	Unit
All input and output voltages ¹	V_{in}, V_{out}	-0.6 ² to +7.0	V
Voltage on pin A9 and \overline{OE}	V_{ID}	-0.6 ² to +13.0	V
V_{PP} voltage ¹	V_{PP}	-0.6 to +13.5	V
V_{CC} voltage ¹	V_{CC}	-0.6 to +7.0	V
Operating temperature range	T_{opr}	0 to +70	°C
Storage temperature range ³	T_{stg}	-65 to +125	°C
Storage temperature under bias	T_{bias}	-20 to +80	°C

Notes: 1. Relative to V_{SS} .

2. V_{in}, V_{out}, V_{ID} min = -2.0 V for pulse width \leq 20 ns

3. Storage temperature range of device before programming.

Capacitance ($T_a = 25^\circ\text{C}$, $f = 1\text{ MHz}$)

Parameter	Symbol	Min	Typ	Max	Unit	Test Conditions
Input capacitance	Cin	—	—	12	pF	Vin = 0 V
Output capacitance	Cout	—	—	20	pF	Vout = 0 V

Read Operation
DC Characteristics ($V_{CC} = 5\text{ V} \pm 10\%$, $V_{PP} = V_{SS}$ to V_{CC} , $T_a = 0$ to $+70^\circ\text{C}$)

Parameter	Symbol	Min	Typ	Max	Unit	Test Conditions
Input leakage current	I_{LI}	—	—	2	μA	Vin = 5.5 V
Output leakage current	I_{LO}	—	—	2	μA	Vout = 5.5 V/0.45 V
V_{PP} current	I_{PP1}	—	1	20	μA	$V_{PP} = 5.5\text{ V}$
Standby V_{CC} current	I_{SB}	—	—	30	mA	$\overline{CE} = V_{IH}$
Operating V_{CC} current	I_{CC1}	—	—	30	mA	Iout = 0 mA, $f = 1\text{ MHz}$
	I_{CC2}	—	—	120	mA	Iout = 0 mA, $f = 11.8\text{ MHz}$
Input voltage	V_{IL}	-0.3^{*1}	—	0.8	V	
	V_{IH}	2.2	—	$V_{CC} + 1^{*2}$	V	
Output voltage	V_{OL}	—	—	0.45	V	$I_{OL} = 2.1\text{ mA}$
	V_{OH}	2.4	—	—	V	$I_{OH} = -400\ \mu\text{A}$

Notes: 1. V_{IL} min = -1.0 V for pulse width $\leq 50\text{ ns}$

V_{IL} min = -2.0 V for pulse width $\leq 20\text{ ns}$

2. V_{IH} max = $V_{CC} + 1.5\text{ V}$ for pulse width $\leq 20\text{ ns}$

If V_{IH} is over the specified maximum value, read operation cannot be guaranteed.

HN27C4096HG/HCC Series

AC Characteristics ($V_{CC} = 5\text{ V} \pm 10\%$, $V_{PP} = V_{SS}$ to V_{CC} , $T_a = 0$ to $+70^\circ\text{C}$)

Test Conditions

- Input pulse levels: 0.45 to 2.4 V
- Input rise and fall time: ≤ 10 ns
- Output load: 1 TTL gate +100 pF
- Reference levels for measuring timing: 1.5 V, 1.5 V

Parameter	Symbol	HN27C4096H-85		Unit	Test Conditions
		Min	Max		
Address to output delay	t_{ACC}	—	85	ns	$\overline{CE} = \overline{OE} = V_{IL}$
\overline{CE} to output delay	t_{CE}	—	85	ns	$\overline{OE} = V_{IL}$
\overline{OE} to output delay	t_{OE}	—	45	ns	$\overline{CE} = V_{IL}$
\overline{OE} high to output float ^{*1}	t_{DF}	0	30	ns	$\overline{CE} = V_{IL}$
Address to output hold	t_{OH}	5	—	ns	$\overline{CE} = \overline{OE} = V_{IL}$

Note: 1. t_{DF} is defined as the time at which the output achieves the open circuit condition and data is no longer driven.

Read Timing Waveform

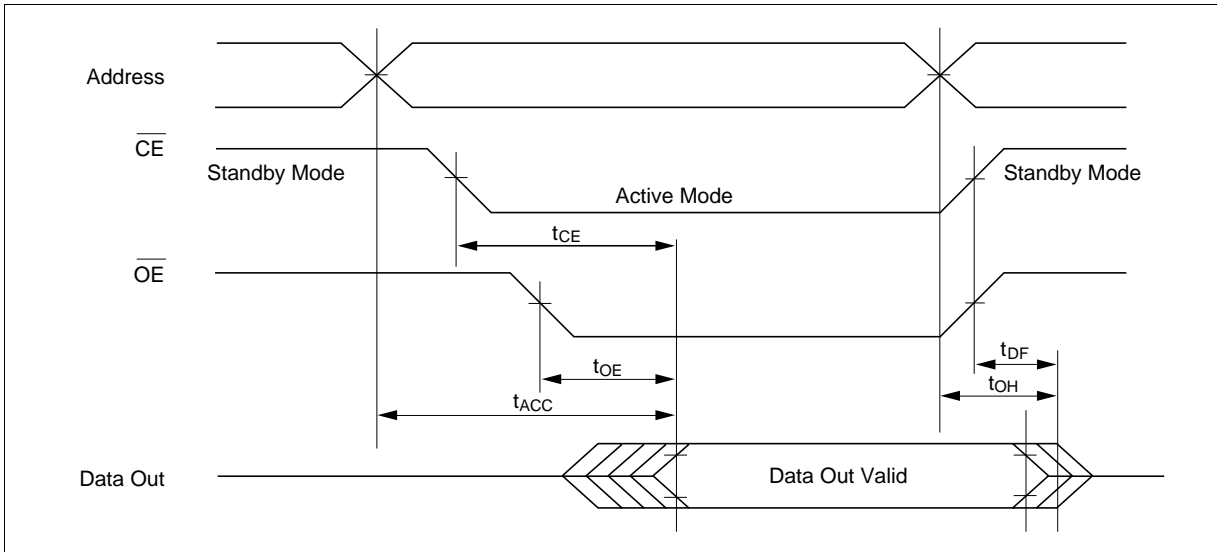

Fast High-Reliability Page Programming

This device can be applied the high performance page programming algorithm shown in the following flowchart. This algorithm allows to obtain faster programming time without any voltage stress to the device nor deterioration in reliability of programmed data.

Page Program Set

Apply 12 V to $\overline{\text{OE}}$ pin after applying 12.5 V to V_{pp} to set a page program mode.

The device operates in a page program mode until reset.

Page Program Reset

Set V_{pp} to V_{CC} level or less to reset a page program mode.

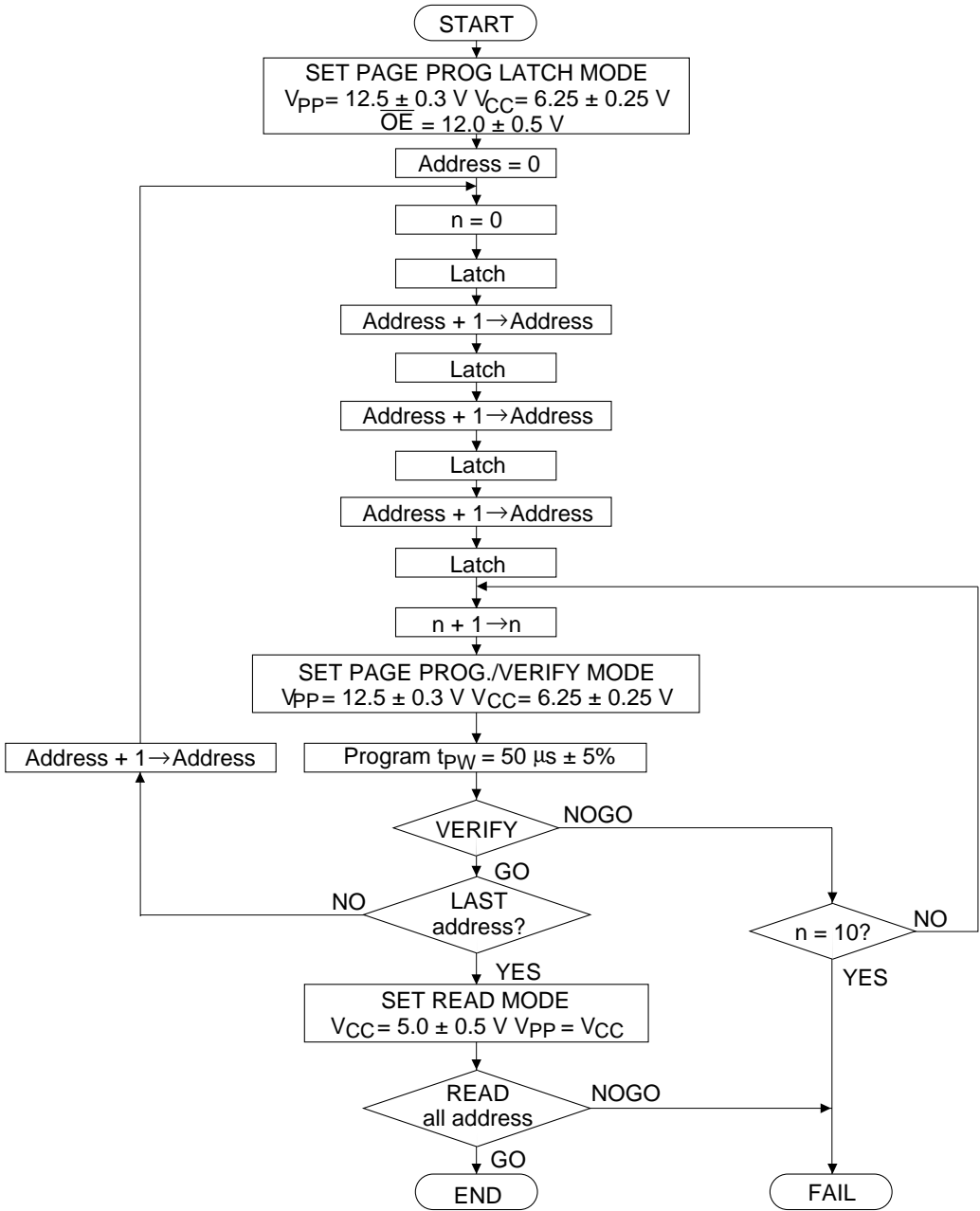

DC Characteristics ($V_{CC} = 6.25 \text{ V} \pm 0.25 \text{ V}$, $V_{PP} = 12.5 \text{ V} \pm 0.3 \text{ V}$, $T_a = 25^\circ\text{C} \pm 5^\circ\text{C}$)

Parameter	Symbol	Min	Typ	Max	Unit	Test Conditions
Input leakage current	I_{LI}	—	—	2	μA	$V_{in} = 6.5 \text{ V}/0.45 \text{ V}$
Output voltage during verify	V_{OL}	—	—	0.45	V	$I_{OL} = 2.1 \text{ mA}$
	V_{OH}	2.4	—	—	V	$I_{OH} = -400 \mu\text{A}$
Operating V_{CC} current	I_{CC}	—	—	50	mA	
Input voltage	V_{IL}	-0.1^{15}	—	0.8	V	
	V_{IH}	2.2	—	$V_{CC} + 0.5^{16}$	V	
	V_H	11.5	12.0	12.5	V	
V_{PP} supply current	I_{PP}	—	—	70	mA	$\overline{CE} = V_{IL}$

- Notes:
- V_{CC} must be applied simultaneously or before V_{PP} and removed simultaneously or after V_{PP} .
 - V_{PP} must not exceed 13.5 V including overshoot.
 - An influence may be had upon device reliability if the device is installed or removed while $V_{PP} = 12.5 \text{ V}$.
 - Do not alter V_{PP} either V_{IL} to 12.5 V or 12.5 V to V_{IL} when $\overline{CE} = \text{low}$.
 - V_{IL} min = -0.6 V for pulse width $\leq 20 \text{ ns}$.
 - If V_{IH} is over the specified maximum value, programming operation cannot be guaranteed.

HN27C4096HG/HCC Series

AC Characteristics ($V_{CC} = 6.25 \text{ V} \pm 0.25 \text{ V}$, $V_{PP} = 12.5 \text{ V} \pm 0.3 \text{ V}$, $T_a = 25^\circ\text{C} \pm 5^\circ\text{C}$)

Test Conditions

- Input pulse levels: 0.45 to 2.4 V
- Input rise and fall time: $\leq 20 \text{ ns}$
- Reference levels for measuring timings: Inputs; 0.8 V, 2.0 V
Outputs; 0.8 V, 2.0 V

Parameter	Symbol	Min	Typ	Max	Unit	Test Conditions
Address setup time	t_{AS}	2	—	—	μs	
\overline{OE} setup time	t_{OES}	2	—	—	μs	
Data setup time	t_{DS}	2	—	—	μs	
Address hold time	t_{AH}	0	—	—	μs	
Data hold time	t_{DH}	2	—	—	μs	
\overline{OE} high to output float delay	t_{DF}^{*1}	0	—	130	ns	
V_{PP} setup time	t_{VPS}	2	—	—	μs	
V_{CC} setup time	t_{VCS}	2	—	—	μs	
\overline{CE} initial programming pulse width	t_{PW}	47.5	50.0	52.5	μs	
\overline{CE} setup time	t_{CES}	2	—	—	μs	
Data valid from \overline{OE}	t_{OE}	0	—	150	ns	
\overline{CE} pulse width during data latch	t_{LW}	1	—	—	μs	
$\overline{OE}=V_H$ setup time	t_{OHS}	2	—	—	μs	
$\overline{OE}=V_H$ hold time	t_{OHH}	2	—	—	μs	
V_{PP} hold time ^{*2}	t_{VRS}	1	—	—	μs	

Notes: 1. t_{DF} is defined as the time at which the output achieves the open circuit condition and data is no longer driven.

2. Page program mode will be reset when V_{PP} is set to V_{CC} or less.

Fast High-Reliability Page Programming Timing Waveform

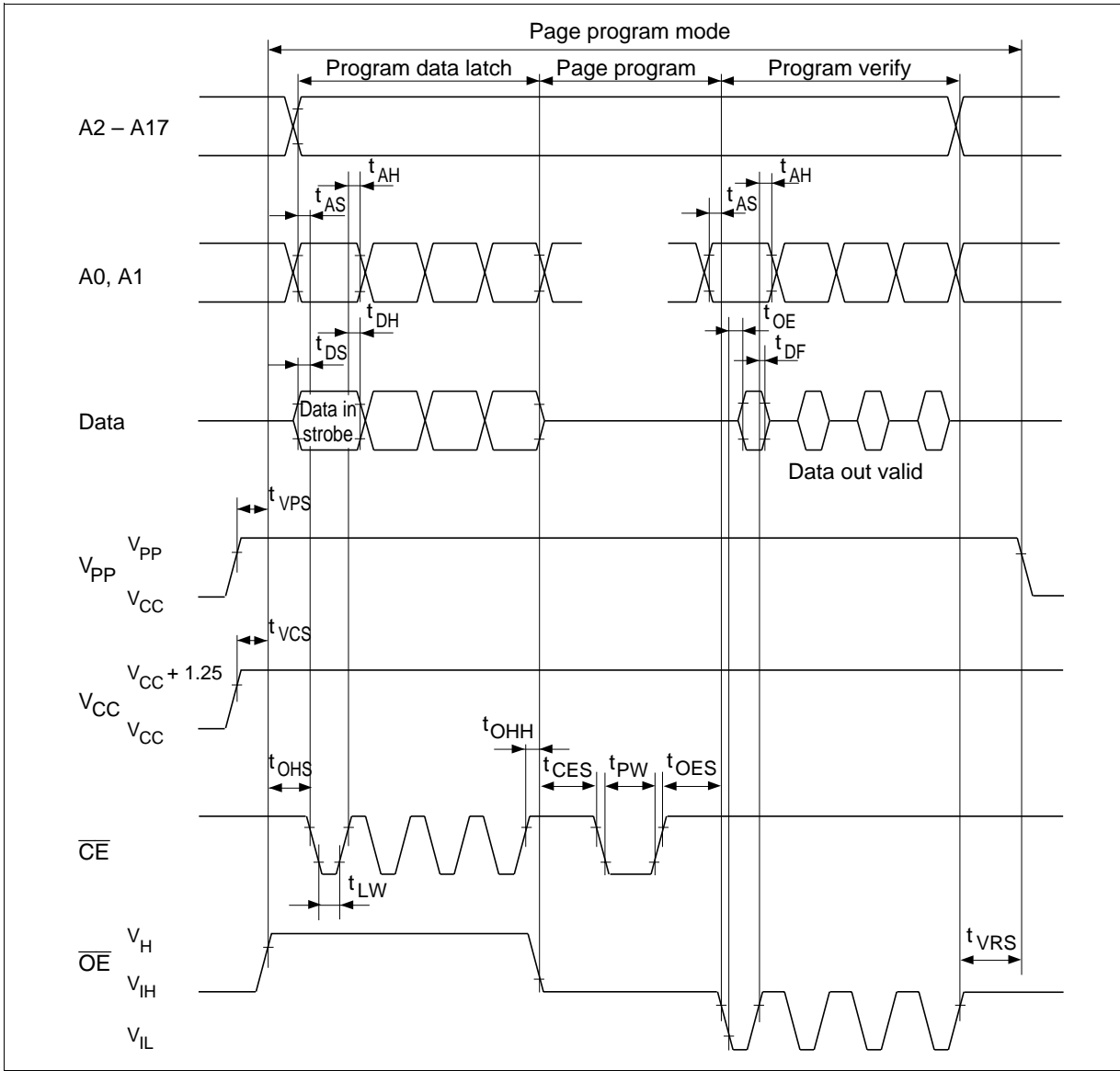

Fast High-Reliability Programming

This device can be applied the fast high-reliability programming algorithm shown in the following flowchart. This algorithm allows to obtain faster programming time without any voltage stress to the device nor deterioration in reliability of programmed data.

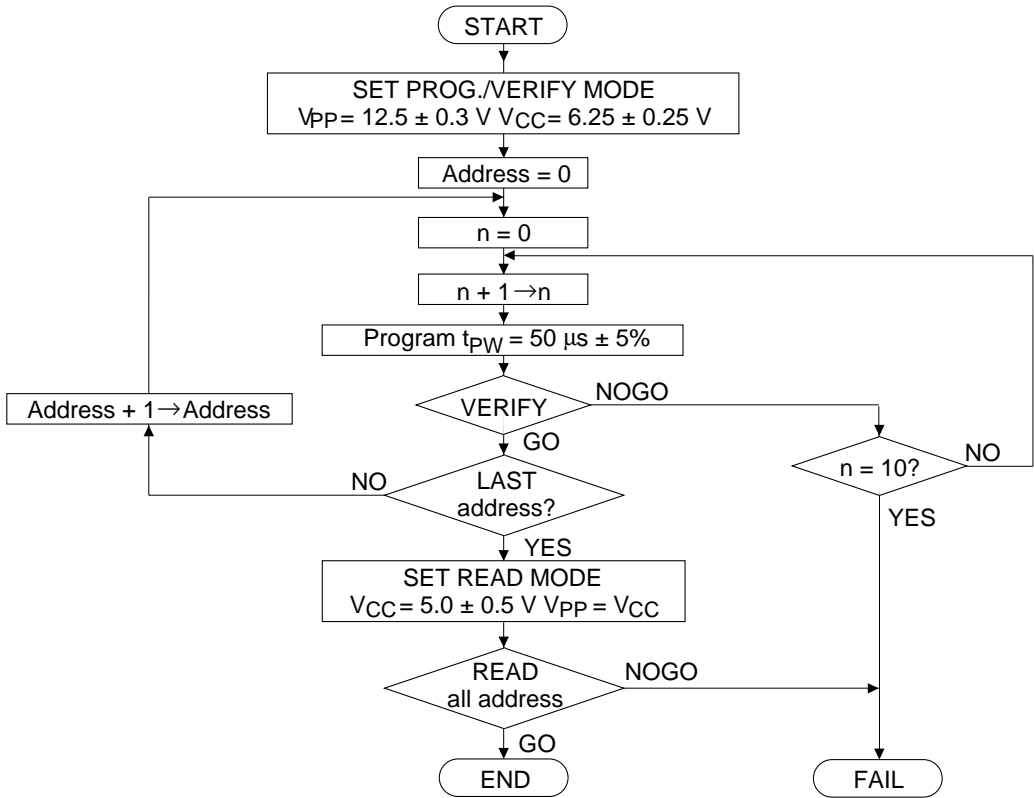

Fast High-Reliability Programming Flowchart

DC Characteristics ($V_{CC} = 6.25 \text{ V} \pm 0.25 \text{ V}$, $V_{PP} = 12.5 \text{ V} \pm 0.3 \text{ V}$, $T_a = 25^\circ\text{C} \pm 5^\circ\text{C}$)

Parameter	Symbol	Min	Typ	Max	Unit	Test Conditions
Input leakage current	I_{LI}	—	—	2	μA	$V_{in} = 6.5 \text{ V}/0.45 \text{ V}$
V_{PP} supply current	I_{PP}	—	—	40	mA	$\overline{CE} = V_{IL}$
Operating V_{CC} current	I_{CC}	—	—	50	mA	
Input voltage	V_{IL}	-0.1^{*5}	—	0.8	V	
	V_{IH}	2.2	—	$V_{CC} + 0.5^{*6}$	V	
Output voltage	V_{OL}	—	—	0.45	V	$I_{OL} = 2.1 \text{ mA}$
	V_{OH}	2.4	—	—	V	$I_{OH} = -400 \mu\text{A}$

- Notes:
- V_{CC} must be applied simultaneously or before V_{PP} and removed simultaneously or after V_{PP} .
 - V_{PP} must not exceed 13.5 V including overshoot.
 - An influence may be had upon device reliability if the device is installed or removed while $V_{PP} = 12.5 \text{ V}$.
 - Do not alter V_{PP} either V_{IL} to 12.5 V or 12.5 V to V_{IL} when $\overline{CE} = \text{low}$.
 - V_{IL} min = -0.6 V for pulse width $\leq 20 \text{ ns}$.
 - If V_{IH} is over the specified maximum value, programming operation cannot be guaranteed.

AC Characteristics ($V_{CC} = 6.25 \text{ V} \pm 0.25 \text{ V}$, $V_{PP} = 12.5 \text{ V} \pm 0.3 \text{ V}$, $T_a = 25^\circ\text{C} \pm 5^\circ\text{C}$)

Test Conditions

- Input pulse levels: 0.45 to 2.4 V
- Input rise and fall time: $\leq 20 \text{ ns}$
- Reference levels for measuring timings: 0.8 V, 2.0 V

Parameter	Symbol	Min	Typ	Max	Unit	Test Conditions
Address setup time	t_{AS}	2	—	—	μs	
\overline{OE} setup time	t_{OES}	2	—	—	μs	
Data setup time	t_{DS}	2	—	—	μs	
Address hold time	t_{AH}	0	—	—	μs	
Data hold time	t_{DH}	2	—	—	μs	
\overline{OE} to output float delay	t_{DF}^{*1}	0	—	130	ns	
V_{PP} setup time	t_{VPS}	2	—	—	μs	
V_{CC} setup time	t_{VCS}	2	—	—	μs	
\overline{CE} initial programming pulse width	t_{PW}	47.5	50.0	52.5	μs	
Data valid from \overline{OE}	t_{OE}	0	—	150	ns	

- Note: 1. t_{DF} is defined as the time at which the output achieves the open circuit condition and data is no longer driven.

Fast High-Reliability Programming Timing Waveform

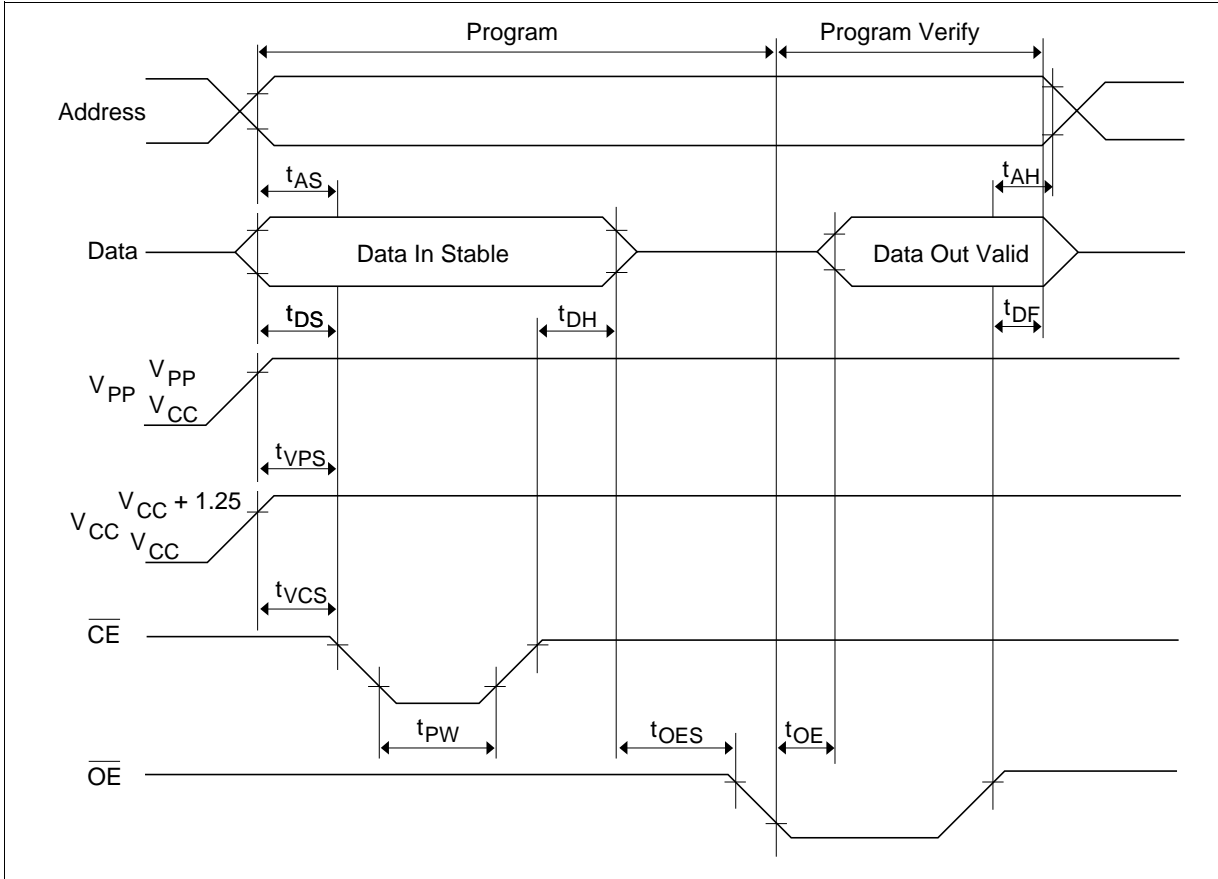

Optional Page Programming

This device can be applied the optional page programming algorithm shown in the following flowchart. This algorithm allows to obtain faster programming time without any voltage stress to the device nor deterioration in reliability of programmed data.

This programming algorithm is the combination of page programming and word verify. It can avoid the increase of programming verify time when a programmer with slow machine cycle is used, and shorten the total programming time.

Regarding the timing specifications for page programming and word verify, please refer to the specifications for fast high-reliability page programming and fast high-reliability programming.

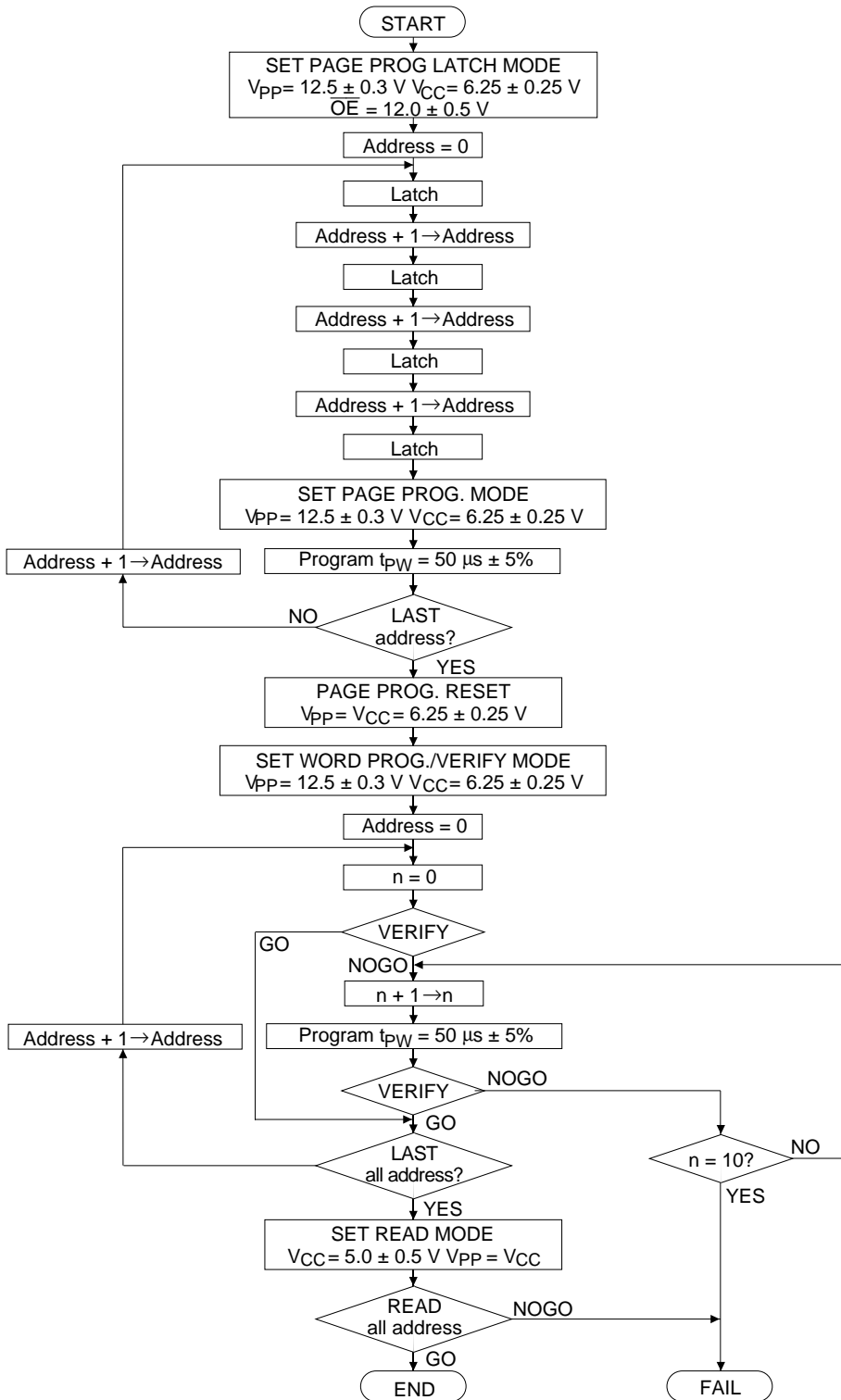

Optional Page Programming Flowchart

HN27C4096HG/HCC Series

DC Characteristics ($V_{CC} = 6.25 \text{ V} \pm 0.25 \text{ V}$, $V_{PP} = 12.5 \text{ V} \pm 0.3 \text{ V}$, $T_a = 25^\circ\text{C} \pm 5^\circ\text{C}$)

Parameter	Symbol	Min	Typ	Max	Unit	Test Conditions
Input leakage current	I_{LI}	—	—	2	μA	$V_{in} = 6.5 \text{ V}/0.45 \text{ V}$
Output voltage during verify	V_{OL}	—	—	0.45	V	$I_{OL} = 2.1 \text{ mA}$
	V_{OH}	2.4	—	—	V	$I_{OH} = -400 \mu\text{A}$
Operating V_{CC} current	I_{CC}	—	—	50	mA	
Input voltage	V_{IL}	-0.1^{*5}	—	0.8	V	
	V_{IH}	2.2	—	$V_{CC} + 0.5^{*6}$	V	
	V_H	11.5	12.0	12.5	V	
V_{PP} supply current	I_{PP}	—	—	70	mA	$\overline{CE} = V_{IL}$

- Notes:
- V_{CC} must be applied simultaneously or before V_{PP} and removed simultaneously or after V_{PP} .
 - V_{PP} must not exceed 13.5 V including overshoot.
 - An influence may be had upon device reliability if the device is installed or removed while $V_{PP} = 12.5 \text{ V}$.
 - Do not alter V_{PP} either V_{IL} to 12.5 V or 12.5 V to V_{IL} when $\overline{CE} = \text{low}$.
 - $V_{IL} \text{ min} = -0.6 \text{ V}$ for pulse width $\leq 20 \text{ ns}$.
 - If V_{IH} is over the specified maximum value, programming operation cannot be guaranteed.

AC Characteristics ($V_{CC} = 6.25 \text{ V} \pm 0.25 \text{ V}$, $V_{PP} = 12.5 \text{ V} \pm 0.3 \text{ V}$, $T_a = 25^\circ\text{C} \pm 5^\circ\text{C}$)

Test Conditions

- Input pulse levels: 0.45 to 2.4 V
- Input rise and fall time: $\leq 20 \text{ ns}$
- Reference levels for measuring timing: Inputs; 0.8 V, 2.0 V,
Outputs; 0.8 V, 2.0 V

Parameter	Symbol	Min	Typ	Max	Unit	Test Conditions
Address setup time	t_{AS}	2	—	—	μs	
\overline{OE} setup time	t_{OES}	2	—	—	μs	
Data setup time	t_{DS}	2	—	—	μs	
Address hold time	t_{AH}	0	—	—	μs	
Data hold time	t_{DH}	2	—	—	μs	
\overline{OE} high to output float delay	t_{DF}^{*1}	0	—	130	ns	
V_{PP} setup time	t_{VPS}	2	—	—	μs	
V_{CC} setup time	t_{VCS}	2	—	—	μs	
\overline{CE} initial programming pulse width	t_{PW}	47.5	50.0	52.5	μs	
\overline{CE} setup time	t_{CES}	2	—	—	μs	
Data valid from \overline{OE}	t_{OE}	0	—	150	ns	
\overline{CE} pulse width during data latch	t_{LW}	1	—	—	μs	
$\overline{OE} = V_H$ setup time	t_{OHS}	2	—	—	μs	
$\overline{OE} = V_H$ hold time	t_{OHH}	2	—	—	μs	
Page programming reset time ^{*2}	t_{VLW}	1	—	—	μs	
V_{PP} hold time ^{*2}	t_{VRS}	1	—	—	μs	

Notes: 1. t_{DF} is defined as the time at which the output achieves the open circuit condition and data is no longer driven.

2. Page program mode will be reset when V_{PP} is set to V_{CC} or less.

Option Page Programming Timing Waveform

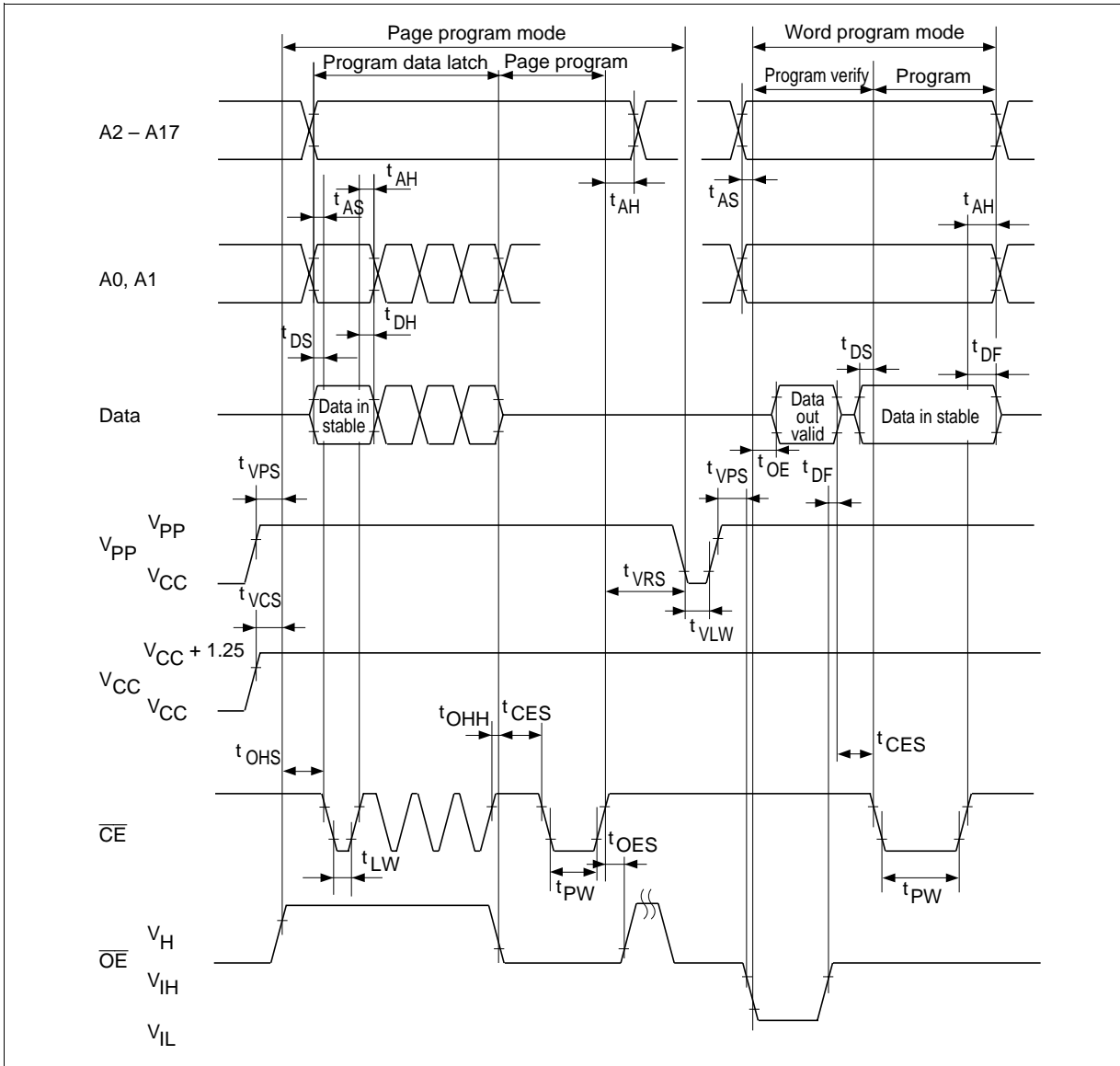

Erase

Erasure of HN27C4096HG/HCC is performed by exposure to ultraviolet light of 2537 Å and all the output data are changed to "1" after this erasure procedure. The minimum integrated dose (i.e. UV intensity × exposure time) for erasure is 15 W•sec/cm².

Mode Description

Device Identifier Mode

The device identifier mode allows the reading out of binary codes that identify manufacturer and type of device, from outputs of EPROM. By this mode, the device will be automatically matched its own corresponding programming algorithm, using programming equipment.

HN27C4096H Identifier Code

	A0	I/O8 – I/O15	I/O7	I/O6	I/O5	I/O4	I/O3	I/O2	I/O1	I/O0		
CC	(24)	(11) – (4)	(14)	(15)	(16)	(17)	(18)	(19)	(20)	(21)		
Identifier	DG-40A	(21)	(10) – (3)	(12)	(13)	(14)	(15)	(16)	(17)	(18)	(19)	Hex Data
Manufacturer code	V_{IL}	X	0	0	0	0	0	0	1	1	1	07
Device code	V_{IH}	X	1	0	1	0	0	0	0	1	0	A2

- Notes: 1. $V_{CC} = 5.0\text{ V} \pm 10\%$
 2. $A9 = 12.0\text{ V} \pm 0.5\text{ V}$
 3. $A1 - A8, A10 - A17, \overline{CE}, \overline{OE} = V_{IL}$
 4. X: Don't care.

HN27C4096HG/HCC Series

Package Dimensions

HN27C4096HG Series (DG-40A)

Unit: mm

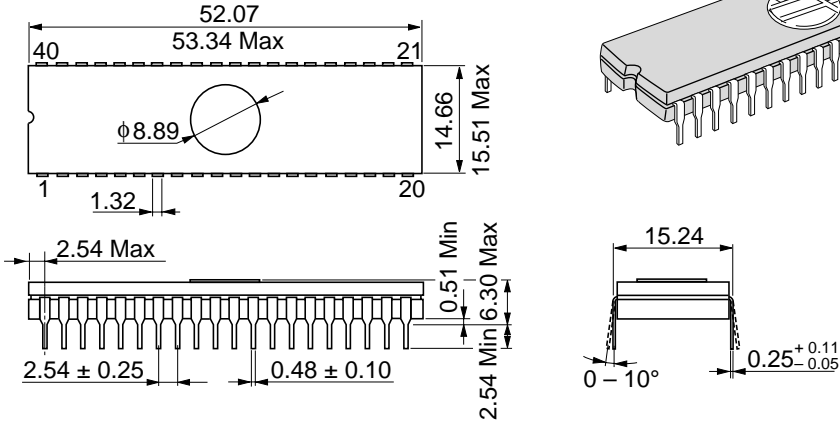

HN27C4096HCC Series (CC-44)

Unit: mm

