

ADVANCE INFORMATION

# VDP 313xY Video Processor Family

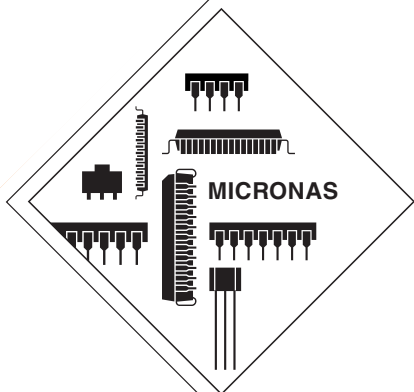

---

**Contents**

<b>Page</b>	<b>Section</b>	<b>Title</b>
<b>5</b>	<b>1.</b>	<b>Introduction</b>
5	1.1.	Features
5	1.2.	System Architecture
6	1.3.	Video Processor Family
<b>7</b>	<b>2.</b>	<b>Functional Description</b>
7	2.1.	Introduction
7	2.2.	Video Front End
7	2.2.1.	Input Selection
7	2.2.2.	Clamping
7	2.2.3.	Automatic Gain Control
7	2.2.4.	Analog-to-Digital Converters
7	2.2.5.	Digitally Controlled Clock Oscillator
8	2.3.	Adaptive Comb Filter
9	2.4.	Color Decoder
9	2.4.1.	IF-Compensation
10	2.4.2.	Demodulator
10	2.4.3.	Chrominance Filter
10	2.4.4.	Frequency Demodulator
10	2.4.5.	Burst Detection / Saturation Control
10	2.4.6.	Color Killer Operation
11	2.4.7.	Automatic standard recognition
11	2.4.8.	PAL Compensation/1-H Comb Filter
12	2.4.9.	Luminance Notch Filter
12	2.4.10.	Skew Filtering
13	2.5.	Horizontal Scaler
13	2.6.	Blackline Detector
13	2.7.	Test Pattern Generator
14	2.8.	Video Sync Processing
14	2.9.	Macrovision detection
15	2.10.	Display Part
15	2.10.1.	Luminance Contrast Adjustment
15	2.10.2.	Black Level Expander
16	2.10.3.	Dynamic Peaking
17	2.10.4.	Digital Brightness Adjustment
17	2.10.5.	Soft Limiter
17	2.10.6.	Chrominance Interpolation
18	2.10.7.	Chrominance Transient Improvement
18	2.10.8.	Inverse Matrix
18	2.10.9.	RGB Processing
18	2.10.10.	Picture Frame Generator
19	2.10.11.	Priority Decoder
19	2.10.12.	Scan Velocity Modulation
19	2.10.13.	Display Phase Shifter
21	2.11.	Video Back End
21	2.11.1.	CRT Measurement and Control
22	2.11.2.	SCART Output Signal

**Contents, continued**

<b>Page</b>	<b>Section</b>	<b>Title</b>
23	2.11.3.	Average Beam Current Limiter
23	2.11.4.	Analog RGB Insertion
24	2.11.5.	Fast Blank Monitor
24	2.11.6.	Half Contrast Control
24	2.11.7.	IO Port Expander
26	2.12.	Synchronization and Deflection
26	2.12.1.	Deflection Processing
27	2.12.2.	Angle & Bow Correction
27	2.12.3.	Horizontal Phase Adjustment
27	2.12.4.	Vertical and East/West Deflection
28	2.12.5.	EHT Compensation
28	2.12.6.	Protection Circuitry
28	2.13.	Reset and Power On
29	2.14.	Serial Interface
29	2.14.1.	I <sup>2</sup> C-Bus Interface
30	2.14.2.	Control and Status Registers
48	2.14.2.1.	Scaler Adjustment
51	2.14.2.2.	Calculation of Vertical and East-West Deflection Coefficients
<b>52</b>	<b>3.</b>	<b>Specifications</b>
52	3.1.	Outline Dimensions
52	3.2.	Pin Connections and Short Descriptions
55	3.3.	Pin Descriptions
56	3.4.	Pin Configuration
57	3.5.	Pin Circuits
59	3.6.	Electrical Characteristics
59	3.6.1.	Absolute Maximum Ratings
59	3.6.2.	Recommended Operating Conditions
60	3.6.2.1.	Analog Input and Output Recommendations
61	3.6.3.	Recommended Crystal Characteristics
62	3.6.4.	Characteristics
62	3.6.4.1.	General Characteristics
62	3.6.4.2.	I <sup>2</sup> C Bus Interface
62	3.6.4.3.	Reset Input
63	3.6.4.4.	Power-up Sequence
64	3.6.4.5.	Test Input
64	3.6.4.6.	Analog Video Front-End and A/D Converters
66	3.6.4.7.	Horizontal Flyback Input
66	3.6.4.8.	Horizontal Drive Output
66	3.6.4.9.	Vertical Protection Input
66	3.6.4.10.	Vertical Safety Input
67	3.6.4.11.	Vertical and East/West D/A Converter Output
67	3.6.4.12.	Combined Sync, Vertical Sync, Interlace and Front Sync Output
67	3.6.4.13.	CLK20 Output
67	3.6.4.14.	Sense A/D Converter Input
67	3.6.4.15.	Range Switch Output
68	3.6.4.16.	Scan Velocity Modulation Output

**Contents, continued**

<b>Page</b>	<b>Section</b>	<b>Title</b>
68	3.6.4.17.	D/A Converter Reference
69	3.6.4.18.	Analog RGB and FB Inputs
70	3.6.4.19.	Half Contrast Switch Input
70	3.6.4.20.	Analog RGB Outputs, D/A Converters
73	3.6.4.21.	IO Ports
<b>74</b>	<b>4.</b>	<b>Application Circuit</b>
<b>76</b>	<b>5.</b>	<b>Data Sheet History</b>

**Video Processor Family**

**1. Introduction**

The VDP 313xY is a video IC family of high-quality single-chip video processors. Modular design and a sub-micron technology allow the economic integration of features in all classes of TV sets. The VDP 313xY family is based on the VDP 31xxB including YC<sub>R</sub>C<sub>B</sub> inputs for DVD component signals.

The main features of the VDP 3130Y are

**1.1. Features**

**Video Decoding and Processing**

- four CVBS, one S-VHS input, one YC<sub>R</sub>C<sub>B</sub> component input
- integrated high-quality A/D converters and associated clamp and AGC circuits
- adaptive 2H comb filter Y/C separator
- multistandard color decoder PAL/NTSC/SECAM including all substandards
- multistandard sync decoder
- automatic standard recognition
- black-line detector
- linear horizontal scaling (0.25...4), as well as nonlinear horizontal scaling "Panoramavision"

- black-level expander
- dynamic peaking
- soft limiter (gamma correction)
- color transient improvement

**RGB Processing and Deflection**

- programmable RGB matrix
- two analog RGB / Fastblank inputs
- half-contrast switch
- picture frame generator
- scan velocity modulation output
- high-performance H/V deflection
- separate ADC for tube measurements
- EHT compensation
- angle and bow correction
- one 20.25 MHz crystal, few external components
- I<sup>2</sup>C-Bus Interface
- 64-pin PSDIP package

**1.2. System Architecture**

Fig. 1-1 shows the block diagram of the video processor

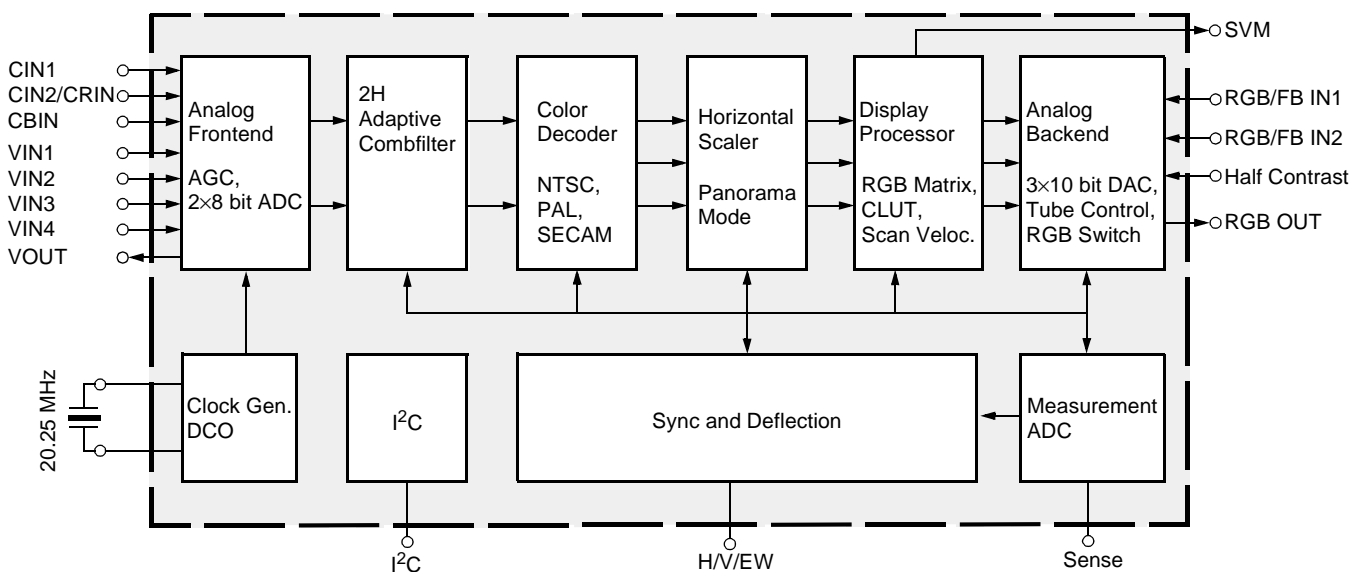

**Fig. 1-1:** Block diagram of the VDP 313xY

**1.3. Video Processor Family**

Each member of the family contains the entire video, display, and deflection processing for 4:3 and 16:9, 50/60 Hz TV sets. Its performance and flexibility allow the user to standardize his product development. Hardware and software applications can profit from the modularity, as well as manufacturing, systems support or maintenance. An overview of the VDP 313xY video processor family is shown in Fig. 1–2.

The new VDP 313xY family is the next generation of Video and Deflection Processors. The main differences towards the VDP 31xxB family are

- YC<sub>R</sub>C<sub>B</sub> component input
- angle and bow correction
- automatic standard recognition
- detection of Macrovision signals
- no dig. RGB interface for TPU 3050
- no stand-by input mode and CLK5 output
- minor changes of pinout

VDP 313xY Family	1H Combfilter	2H adapt. Comb	Horizontal Scaler	Color Trans. Impr.	Scan Vel. Mod.	Prog. RGB Matrix	RGB Insertion	Tube Control
VDP 3134Y	✓					✓	✓	✓
VDP 3133Y	✓			✓	✓	✓	✓	✓
VDP 3132Y	✓	✓		✓	✓	✓	✓	✓
VDP 3131Y	✓		✓	✓	✓	✓	✓	✓
VDP 3130Y	✓	✓	✓	✓	✓	✓	✓	✓

Fig. 1–2: VDP 313xY family overview

**2. Functional Description**

**2.1. Introduction**

The VDP 313xY includes complete video, display and deflection processing. All processing is done digitally, the video frontend and video backend are interfacing to the analog world. Most functions of the VDP can be controlled by software via I<sup>2</sup>C-Bus interface (see Section 2.14.1. on page 29).

**2.2. Video Front End**

This block provides the analog interfaces to all video inputs and mainly carries out analog-to-digital conversion for the following digital video processing. A block diagram is given in Fig. 2–1.

Most of the functional blocks in the front-end are digitally controlled (clamping, AGC, and clock-DCO). The control loops are closed by the Fast Processor (FP) embedded in the video decoder.

**2.2.1. Input Selection**

Up to seven analog inputs can be connected. Four inputs are for input of composite video or S-VHS luminance signal. These inputs are clamped to the sync back porch and are amplified by a variable gain amplifier. Two inputs are for connection of S-VHS carrier-chrominance signal. These inputs are internally biased and have a fixed gain amplifier. For analog YC<sub>R</sub>C<sub>B</sub> signals (e.g. from DVD players) the selected luminance input is used together with CBIN and CRIN.

**2.2.2. Clamping**

The composite video input signals are AC coupled to the IC. The clamping voltage is stored on the coupling capacitors and is generated by digitally controlled cur-

rent sources. The clamping level is the back porch of the video signal.

S-VHS chrominance is also AC coupled. The input pin is internally biased to the center of the ADC input range.

The chrominance inputs for YC<sub>R</sub>C<sub>B</sub> need to be AC coupled using clamping capacitors. It is strongly recommended to use 5 MHz anti-alias low-pass filters on each input. Each channel is sampled at 10.125 MHz with a resolution of 8 bit and a clamping level of 128.

**2.2.3. Automatic Gain Control**

A digitally working automatic gain control adjusts the magnitude of the selected baseband by +6/–4.5 dB in 64 logarithmic steps to the optimal range of the ADC. The gain of the video input stage including the ADC is 213 steps/V with the AGC set to 0 dB.

The gain of the chrominance path in the YC<sub>R</sub>C<sub>B</sub> mode is fix and adapted to a nominal amplitude of 0.7 V<sub>pp</sub>. However, if an overflow of the ADC occurs an extended signal range of 1 V<sub>pp</sub> can be selected.

**2.2.4. Analog-to-Digital Converters**

Two ADCs are provided to digitize the input signals. Each converter runs with 20.25 MHz and has 8 bit resolution. An integrated bandgap circuit generates the required reference voltages for the converters. The two ADCs are of a 2-stage subranging type.

**2.2.5. Digitally Controlled Clock Oscillator**

The clock generation is also a part of the analog front end. The crystal oscillator is controlled digitally by the control processor. The clock frequency can be adjusted within ±150 ppm.

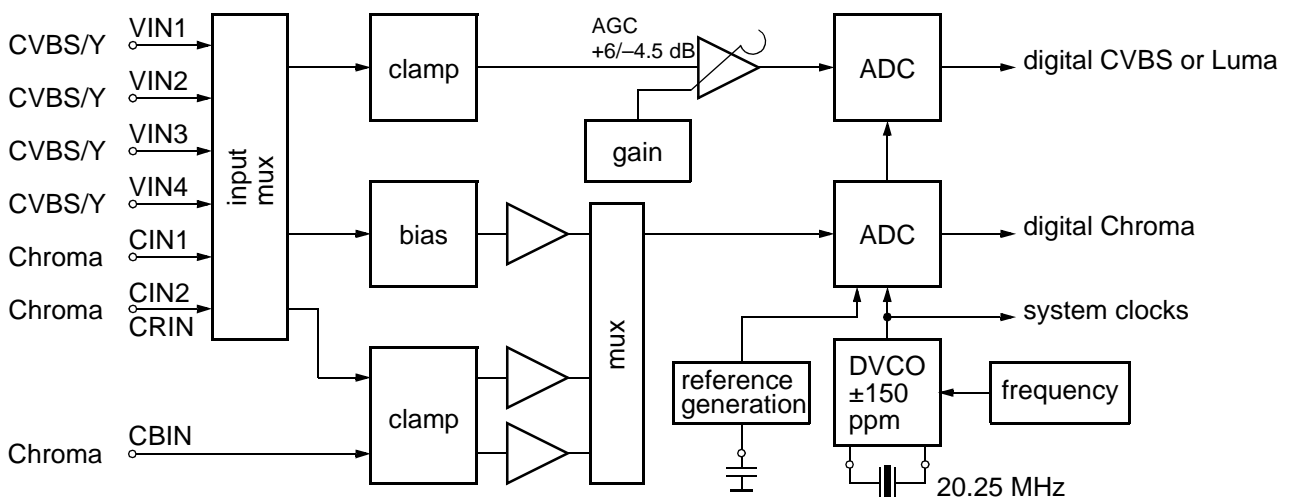

**Fig. 2–1:** Video front-end

### 2.3. Adaptive Comb Filter

The adaptive comb filter is used for high-quality luminance/chrominance separation for PAL or NTSC signals. The comb filter improves the luminance resolution (bandwidth) and reduces interferences like cross-luminance and cross-color artifacts. The adaptive algorithm can eliminate most of the mentioned errors without introducing new artifacts or noise.

A block diagram of the comb filter is shown in Fig. 2–1. The filter uses two line delays to process the information of three adjacent video lines. To have a fixed phase relationship of the color subcarrier in the three channels, the system clock (20.25 MHz) is fractionally locked to the color subcarrier. This allows the processing of all color standards and substandards using a single crystal frequency.

The CVBS signal in the three channels is filtered at the subcarrier frequency by a set of bandpass/notch filters. The output of the three channels is used by the adaption logic to select the weighting that is used to reconstruct the luminance/chrominance signal from the 4 bandpass/notch filter signals. By using soft mixing of the 4 signals switching artifacts of the adaption algorithm are completely suppressed.

The comb filter uses the middle line as reference, therefore, the comb filter delay is one line. If the comb filter is switched off, the delay lines are used to pass the luminance/ chrominance signals from the A/D converters to the luminance/ chrominance outputs. Thus, the comb filter delay is always one line.

Various parameters of the comb filter are adjustable, hence giving to the user the ability to adjust his own desired picture quality.

Two parameters (KY, KC) set the global gain of luminance and chrominance comb separately; these values directly weigh the adaption algorithm output. In this way, it is possible to obtain a luminance/chrominance separation ranging from standard notch/band-pass to full comb decoding.

The parameter KB allows to choose between the two proposed comb booster modes. This so-called feature widely improves vertical high to low frequency transitions areas, the typical example being a multiburst to dc change. For KB = 0, this improvement is kept moderate, whereas, in case of KB = 1, it is maximum, but the risk to increase the “hanging dots” amount for some given color transitions is higher.

Using the default setting, the comb filter has separate luminance and chrominance decision algorithms; it is however possible to switch the chrominance comb factor to the current luminance adaption output by setting CC to 1.

Another interesting feature is the programmable limitation of the luminance comb amount; proper limitation, associated to adequate luminance peaking, gives rise to an enhanced 2-D resolution homogeneity. This limitation is set by the parameter CLIM, ranging from 0 (no limitation) to 31 (max. limitation).

The DAA parameter (1:off, 0:on) is used to disable/enable a very efficient built-in “rain effect” suppressor; many comb filters show this side effect which gives some vertical correlation to a 2-D uniform random area, due to the vertical filtering. This unnatural-looking phenomenon is mostly visible on tuner images, since they are always corrupted by some noise; and this looks like rain.

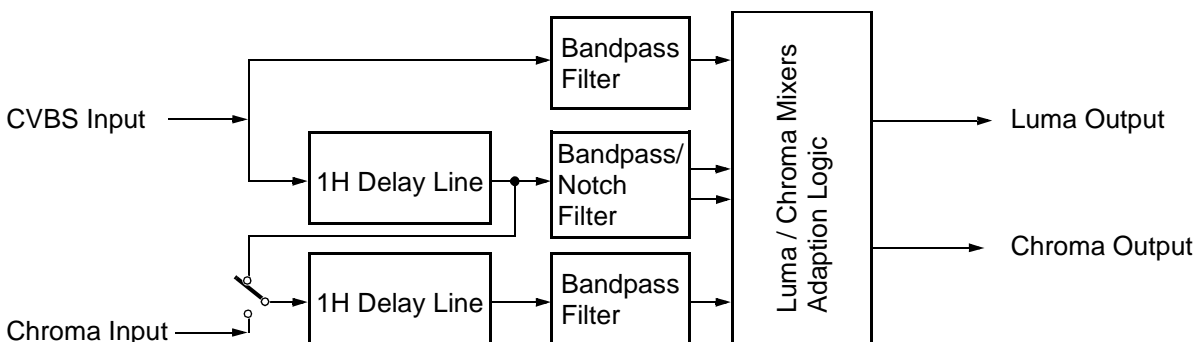

Fig. 2–1: Block diagram of the adaptive comb filter (PAL mode)



**2.4. Color Decoder**

In this block, the standard luminance/chrominance (luma/chroma) separation and multistandard color demodulation is carried out. The color demodulation uses an asynchronous clock, thus allowing a unified architecture for all color standards.

A block diagram of the color decoder is shown in Fig. 2-3. The luminance as well as the chrominance processing, is shown here. The color decoder provides also some special modes, e.g. wide band chrominance format which is intended for S-VHS wide bandwidth chrominance.

If the adaptive comb filter is used for luminance/chrominance separation, the color decoder uses the S-VHS mode processing. The output of the color decoder is  $Y C_R C_B$  in a 4:2:2 format.

**2.4.1. IF-Compensation**

With off-air or mistuned reception, any attenuation at higher frequencies or asymmetry around the color subcarrier is compensated. Four different settings of the IF-compensation are possible:

- flat (no compensation)
- 6 dB/octave
- 12 dB/octave
- 10 dB/MHz

The last setting gives a very large boost to high frequencies. It is provided for SECAM signals that are decoded using a SAW filter specified originally for the PAL standard.

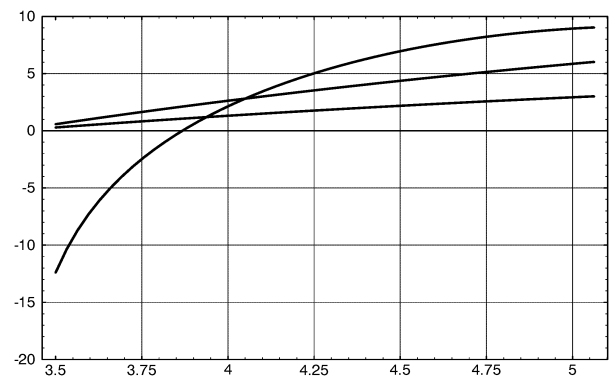

**Fig. 2-2:** Frequency response of chrominance IF-compensation

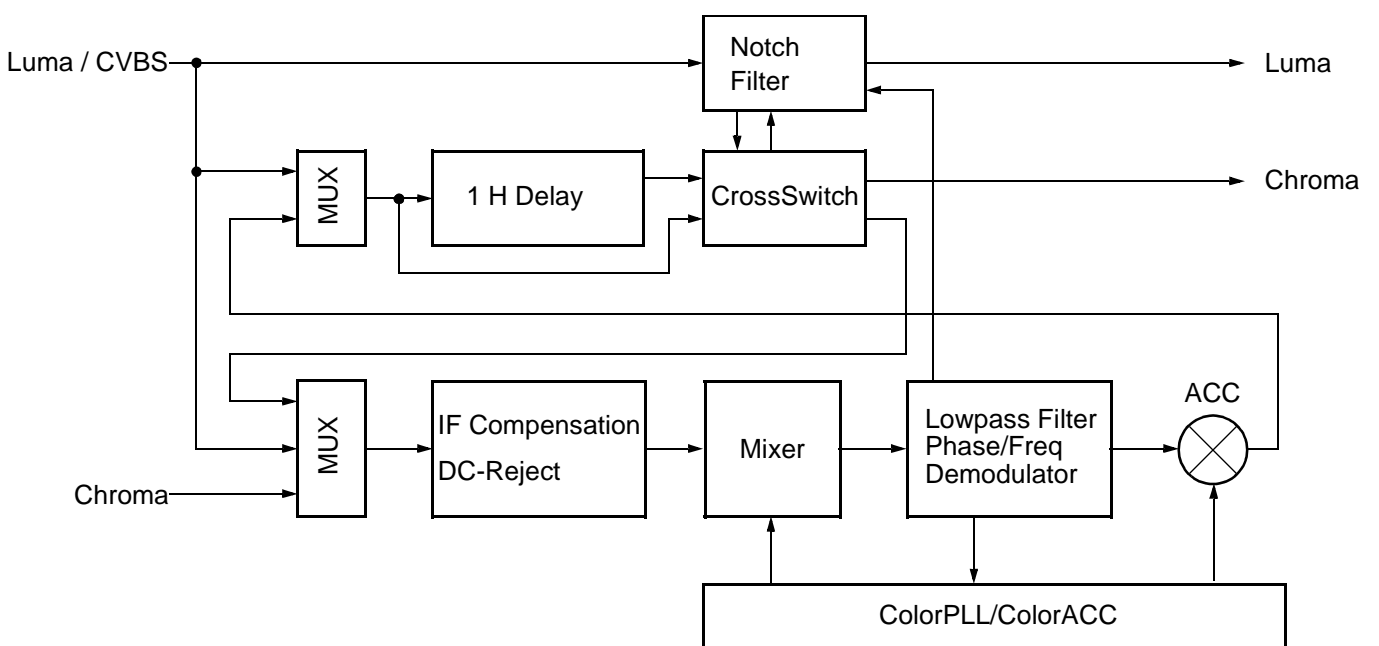

**Fig. 2-3:** Color decoder

### 2.4.2. Demodulator

The entire signal (which might still contain luminance) is now quadrature-mixed to the baseband. The mixing frequency is equal to the subcarrier for PAL and NTSC, thus achieving the chrominance demodulation. For SECAM, the mixing frequency is 4.286 MHz giving the quadrature baseband components of the FM modulated chrominance. After the mixer, a lowpass filter selects the chrominance components; a downsampling stage converts the color difference signals to a multiplexed half rate data stream.

The subcarrier frequency in the demodulator is generated by direct digital synthesis; therefore, substandards such as PAL 3.58 or NTSC 4.43 can also be demodulated.

### 2.4.3. Chrominance Filter

The demodulation is followed by a lowpass filter for the color difference signals for PAL/NTSC. SECAM requires a modified lowpass function with bell-filter characteristic. At the output of the lowpass filter, all luminance information is eliminated.

The lowpass filters are calculated in time multiplex for the two color signals. Three bandwidth settings (narrow, normal, broad) are available for each standard. For PAL/NTSC, a wide band chrominance filter can be selected. This filter is intended for high bandwidth chrominance signals, e.g. a nonstandard wide bandwidth S-VHS signal.

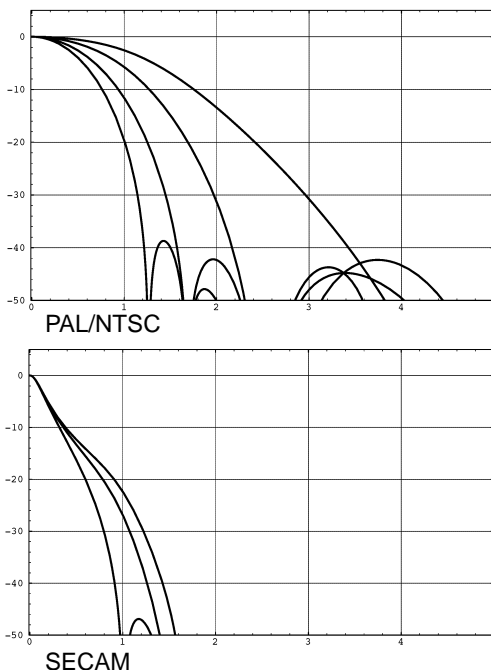

Fig. 2-4: Frequency response of chrominance filters

### 2.4.4. Frequency Demodulator

The frequency demodulator for demodulating the SECAM signal is implemented as a CORDIC-structure. It calculates the phase and magnitude of the quadrature components by coordinate rotation.

The phase output of the CORDIC processor is differentiated to obtain the demodulated frequency. After the deemphasis filter, the  $D_r$  and  $D_b$  signals are scaled to standard  $C_R C_B$  amplitudes and fed to the cross-over-switch.

### 2.4.5. Burst Detection / Saturation Control

In the PAL/NTSC-system the burst is the reference for the color signal. The phase and magnitude outputs of the CORDIC are gated with the color key and used for controlling the phase-lock-loop (APC) of the demodulator and the automatic color control (ACC) in PAL/NTSC.

The ACC has a control range of +30...-6 dB.

Color saturation can be selected once for all color standards. In PAL/NTSC it is used as reference for the ACC. In SECAM the necessary gains are calculated automatically.

For SECAM decoding, the frequency of the burst is measured. Thus, the current chrominance carrier frequency can be identified and is used to control the SECAM processing. The burst measurements also control the color killer operation; they are used for automatic standard detection as well.

### 2.4.6. Color Killer Operation

The color killer uses the burst-phase/burst-frequency measurement to identify a PAL/NTSC or SECAM color signal. For PAL/NTSC, the color is switched off (killed) as long as the color subcarrier PLL is not locked. For SECAM, the killer is controlled by the toggle of the burst frequency. The burst amplitude measurement is used to switch-off the color if the burst amplitude is below a programmable threshold. Thus, color will be killed for very noisy signals. The color amplitude killer has a programmable hysteresis.

**2.4.7. Automatic standard recognition**

The burst-frequency measurement is also used for automatic standard recognition (together with the status of horizontal and vertical locking) thus allowing a completely independent search of the line and color standard of the input signal. The following standards can be distinguished:

- PAL B,G,H,I
- NTSC M
- SECAM
- NTSC 44
- PAL M
- PAL N
- PAL 60

For a preselection of allowed standards, the recognition can be enabled/disabled via I<sup>2</sup>C bus for each standard separately.

If at least one standard is enabled, the VDP 313xY checks regularly the horizontal and vertical locking of the input signal and the state of the color killer. If an error exists for several adjacent fields a new standard search is started. Depending on the measured line number and burst frequency the current standard is selected.

For error handling the recognition algorithm delivers the following status information:

- search active (busy)
- search terminated, but failed
- found standard is disabled
- vertical standard invalid
- no color found
- standard switched

**2.4.8. PAL Compensation/1-H Comb Filter**

The color decoder uses one fully integrated delay line. Only active video is stored.

The delay line application depends on the color standard:

- NTSC: 1-H comb filter **or** color compensation
- PAL: color compensation
- SECAM: crossover-switch

In the NTSC compensated mode, Fig. 2-5 c), the color signal is averaged for two adjacent lines. Thus, cross-color distortion and chrominance noise is reduced. In the NTSC combfilter mode, Fig. 2-5 d), the delay line is in the composite signal path, thus allowing reduction of cross-color components, as well as cross-luminance. The loss of vertical resolution in the luminance channel is compensated by adding the vertical detail signal with removed color information. If the 2-H adaptive comb filter is used, then the 1-H NTSC comb filter should not be used.

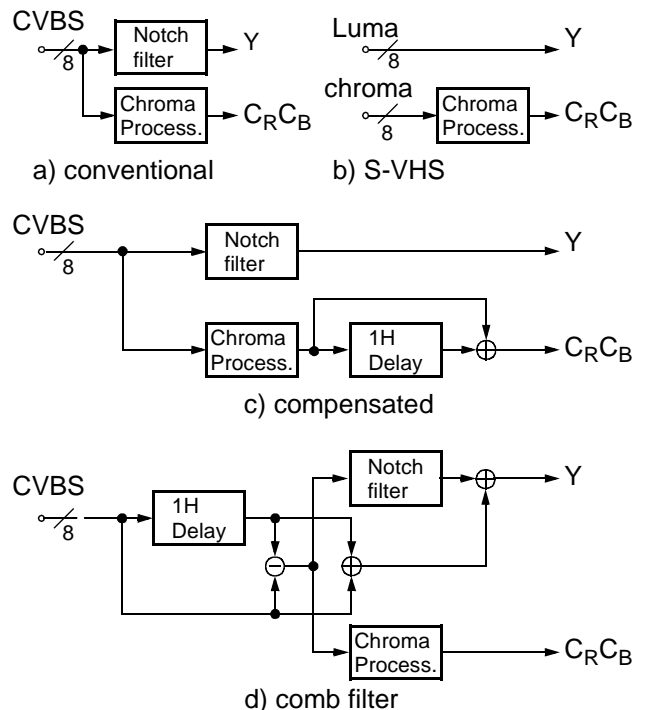

**Fig. 2-5:** NTSC color decoding options

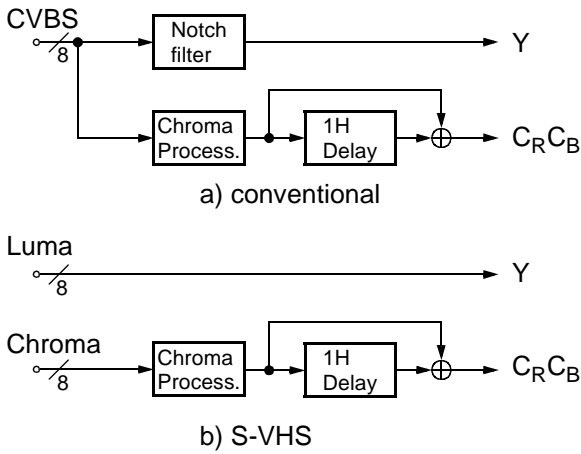

Fig. 2-6: PAL color decoding options

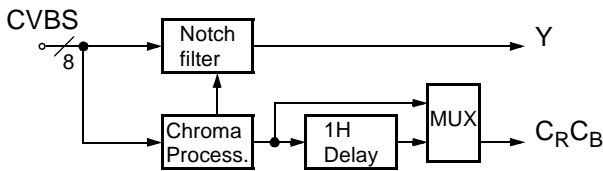
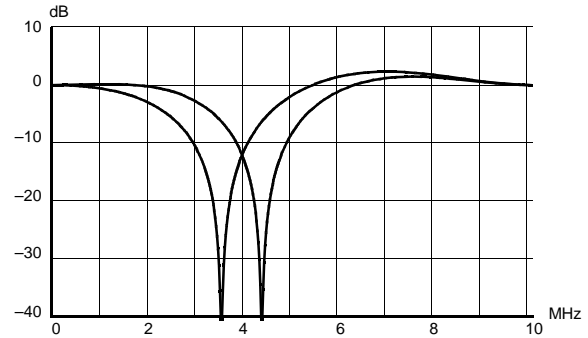

Fig. 2-7: SECAM color decoding

2.4.9. Luminance Notch Filter

If a composite video signal is applied, the color information is suppressed by a programmable notch filter. The position of the filter center frequency depends on the subcarrier frequency for PAL/NTSC. For SECAM, the notch is directly controlled by the chrominance carrier frequency. This considerably reduces the cross-luminance. The frequency responses for all three systems are shown in Fig. 2-8.



PAL/NTSC notch filter

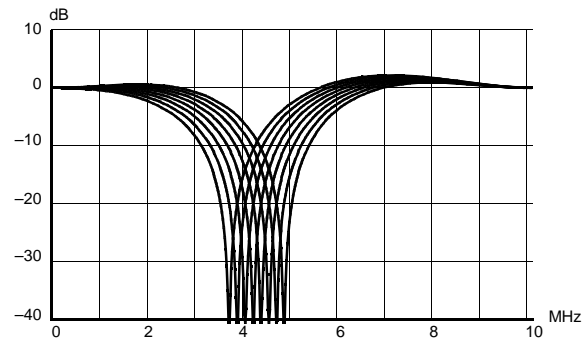

SECAM notch filter

Fig. 2-8: Frequency responses of the luminance notch filter for PAL, NTSC, SECAM

2.4.10. Skew Filtering

The system clock is free-running and not locked to the TV line frequency. Therefore, the ADC sampling pattern is not orthogonal. The decoded  $Y C_R C_B$  signals are converted to an orthogonal sampling raster by the skew filters, which are part of the scaler block.

The skew filters allow the application of a group delay to the input signals without introducing waveform or frequency response distortion.

The amount of phase shift of this filter is controlled by the horizontal PLL1. The accuracy of the filters is 1/32 clocks for luminance and 1/4 clocks for chrominance. Thus the 4:2:2  $Y C_R C_B$  data is in an orthogonal pixel format even in the case of nonstandard input signals such as VCR.

**2.5. Horizontal Scaler**

The 4:2:2 YC<sub>R</sub>C<sub>B</sub> signal from the color decoder is processed by the horizontal scaler. The scaler block allows a linear or nonlinear horizontal scaling of the input video signal in the range of 0.25 to 4. Nonlinear scaling, also called panorama vision, provides a geometrical distortion of the input picture. It is used to fit a picture with 4:3 format on a 16:9 screen by stretching the picture geometry at the borders. Also, the inverse effect can be produced by the scaler. A summary of scaler modes is given in Table 2–1.

The scaler contains a programmable decimation filter, a 1-line FIFO memory, and a programmable interpolation filter. The scaler input filter is also used for pixel skew correction (see Section 2.4.10. on page 12). The decimator/interpolator structure allows optimal use of the FIFO memory. The controlling of the scaler is done by the internal Fast Processor.

**Table 2–1:** Scaler modes

Mode	Scale Factor	Description
Compression 4:3 → 16:9	0.75 linear	4:3 source displayed on a 16:9 tube, with side panels
Panorama 4:3 → 16:9	non-linear compr	4:3 source displayed on a 16:9 tube, Borders distorted
Zoom 4:3 → 4:3	1.33 linear	Letterbox source (PAL+) displayed on a 4:3 tube, vertical overscan with cropping of side panels
Panorama 4:3 → 4:3	non-linear zoom	Letterbox source (PAL+) displayed on a 4:3 tube, vertical overscan, borders distorted, no cropping

**2.6. Blackline Detector**

In case of a letterbox format input video, e.g. Cinemascope, PAL+ etc., black areas at the upper and lower part of the picture are visible. It is suitable to remove or reduce these areas by a vertical zoom and/or shift operation.

The VDP 313xY supports this feature by a letterbox detector. The circuitry detects black video lines by measuring the signal amplitude during active video. For every field the number of black lines at the upper and lower part of the picture are measured, compared to the previous measurement and the minima are stored in the I<sup>2</sup>C-register BLKLIN. To adjust the picture amplitude, the external controller reads this register, calculates the vertical scaling coefficient and transfers the new settings, e.g. vertical sawtooth parameters, horizontal scaling coefficient etc., to the VDP 313xY.

Letterbox signals containing logos on the left or right side of the black areas are processed as black lines, while subtitles, inserted in the black areas, are processed as non-black lines. Therefore the subtitles are visible on the screen. To suppress the subtitles, the vertical zoom coefficient is calculated by selecting the larger number of black lines only. Dark video scenes with a low contrast level compared to the letterbox area are indicated by the BLKPIC bit.

**2.7. Test Pattern Generator**

The YC<sub>R</sub>C<sub>B</sub> outputs can be switched to a test mode where YC<sub>R</sub>C<sub>B</sub> data are generated digitally in the VDP 313xY. Test patterns include luminance/chrominance ramps and flat fields.

## 2.8. Video Sync Processing

Fig. 2–9 shows a block diagram of the front-end sync processing. To extract the sync information from the video signal, a linear phase lowpass filter eliminates all noise and video contents above 1 MHz. The sync is separated by a slicer; the sync phase is measured. A variable window can be selected to improve the noise immunity of the slicer. The phase comparator measures the falling edge of sync, as well as the integrated sync pulse.

The sync phase error is filtered by a phase-locked loop that is computed by the FP. All timing in the front-end is derived from a counter that is part of this PLL, and it thus counts synchronously to the video signal.

A separate hardware block measures the signal back porch and also allows gathering the maximum/minimum of the video signal. This information is processed by the FP and used for gain control and clamping.

For vertical sync separation, the sliced video signal is integrated. The FP uses the integrator value to derive vertical sync and field information.

The information extracted by the video sync processing is multiplexed onto the hardware front sync signal (FSY) and is distributed to the rest of the video processing system.

The data for the vertical deflection, the sawtooth, and the East-West correction signal is calculated by the VDP 313xY. The data is buffered in a FIFO and transferred to the back-end by a single wire interface.

Frequency and phase characteristics of the analog video signal are derived from PLL1. The results are fed to the scaler unit for data interpolation and orthogonalization and to the clock synthesizer for line-locked clock generation. Horizontal and vertical syncs are latched with the line-locked clock.

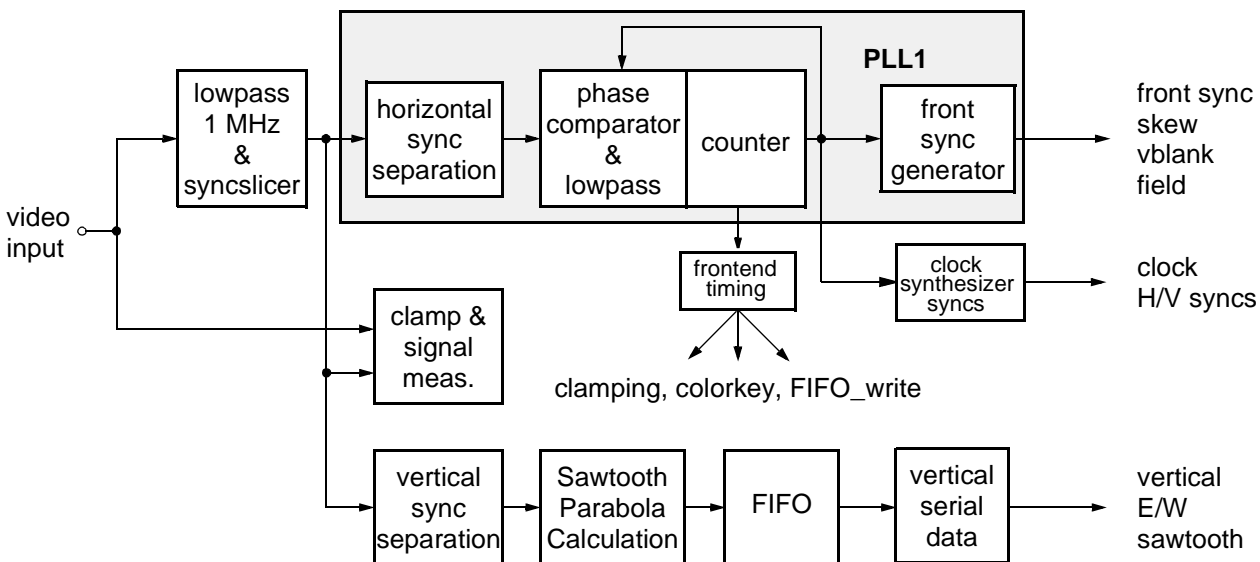

Fig. 2–9: Sync separation block diagram

## 2.9. Macrovision detection

Video signals from Macrovision encoded VCR tapes are decoded without loss of picture quality. However, it might be necessary in some applications to detect the presence of Macrovision encoded video signals. This is possible by reading the Macrovision status register (MCV\_STATUS).

Macrovision encoded video signals typically have AGC pulses and pseudo sync pulses added during VBI. The amplitude of the AGC pulses is modulated in time. The Macrovision detection logic measures the VBI lines and compares the signal against thresholds.

The window in which the video lines are checked for Macrovision pulses can be defined in terms of start and stop line (e.g. 6-15 for NTSC).

**2.10.Display Part**

In the display part the conversion from digital  $YC_R C_B$  to analog RGB is carried out (see Fig. 2-17 on page 20). In the luminance processing path, contrast and brightness adjustments and a variety of features, such as black level expansion, dynamic peaking and soft limiting, are provided. In the chrominance path, the  $C_R C_B$  signals are converted to 4:4:4 format and filtered by a color transient improvement circuit. The  $YC_R C_B$  signals are converted by a programmable matrix to RGB color space.

The display processor can switch between two separate control settings (main/side) for contrast, brightness and matrix coefficients.

**2.10.1.Luminance Contrast Adjustment**

The contrast of the luminance signal can be adjusted by multiplication with a 6-bit contrast value. The contrast value corresponds to a gain factor from 0 to 2, where the value 32 is equivalent to a gain of 1.

**2.10.2.Black Level Expander**

The black level expander enhances the contrast of the picture. Therefore the luminance signal is modified with an adjustable, non-linear function. Dark areas of

the picture are changed to black, while bright areas remain unchanged. The advantage of this black level expander is that the black expansion is performed only if it will be most noticeable to the viewer.

The black level expander works adaptively. Depending on the measured amplitudes  $L_{min}$  and  $L_{max}$  of the low-pass-filtered luminance (during a programmable vertical window) and an adjustable coefficient BTLT, a tilt point  $L_t$  is established by

$$L_t = L_{min} + BTLT \times (L_{max} - L_{min}).$$

Above this value there is no expansion, while all luminance values below this point are expanded according to:

$$L_{out} = L_{in} + BAM \times (L_{in} - L_t)$$

A second threshold,  $L_{tr}$ , can be programmed, above which there is no expansion. The characteristics of the black level expander are shown in Fig. 2-10 and Fig. 2-11.

The tilt point  $L_t$  is a function of the dynamic range of the video signal. Thus, the black level expansion is only performed when the video signal has a large dynamic range. Otherwise, the expansion to black is zero. This allows the correction of the characteristics of the picture tube.

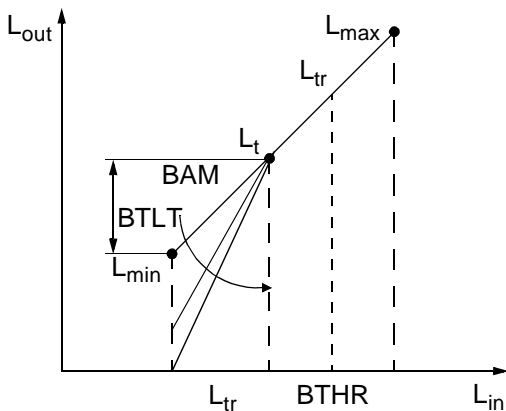

**Fig. 2-10:** Characteristics of the black level expander

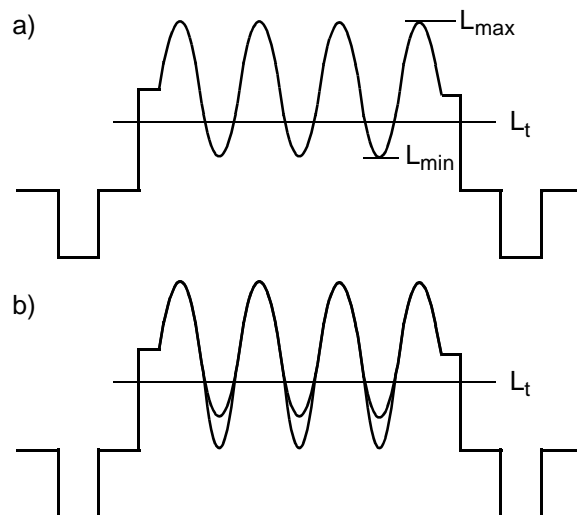

**Fig. 2-11:** Black-level-expansion  
 a) luminance input  
 b) luminance input and output

**2.10.3. Dynamic Peaking**

Especially with decoded composite signals and notch filter luminance separation, as input signals, it is necessary to improve the luminance frequency characteristics. With transparent, high-bandwidth signals, it is sometimes desirable to soften the image.

In the VDP 313xY, the luminance response is improved by dynamic peaking. The algorithm has been optimized regarding step and frequency response. It adapts to the amplitude of the high frequency part. Small AC amplitudes are processed, while large AC amplitudes stay nearly unmodified.

The dynamic range can be adjusted from -14 to +14 dB for small high frequency signals. There is separate adjustment for signal overshoot and for signal undershoot. For large signals, the dynamic range is limited by a non-linear function that does not create any visible alias components. The peaking can be switched over to "softening" by inverting the peaking term by software.

The center frequency of the peaking filter is switchable from 2.5 MHz to 3.2 MHz. For S-VHS and notch filter color decoding, the total system frequency responses for both PAL and NTSC are shown in Fig. 2-13.

Transients, produced by the dynamic peaking when switching to the picture frame can be suppressed optionally

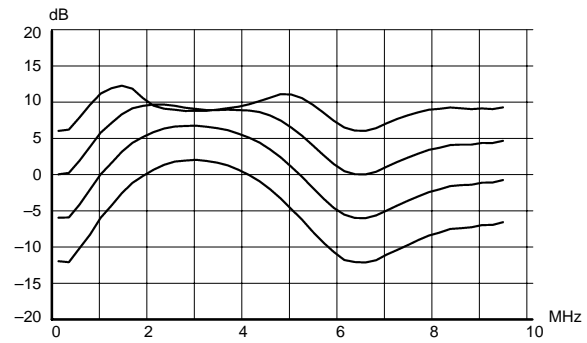

**Fig. 2-12:** Dynamic peaking frequency response

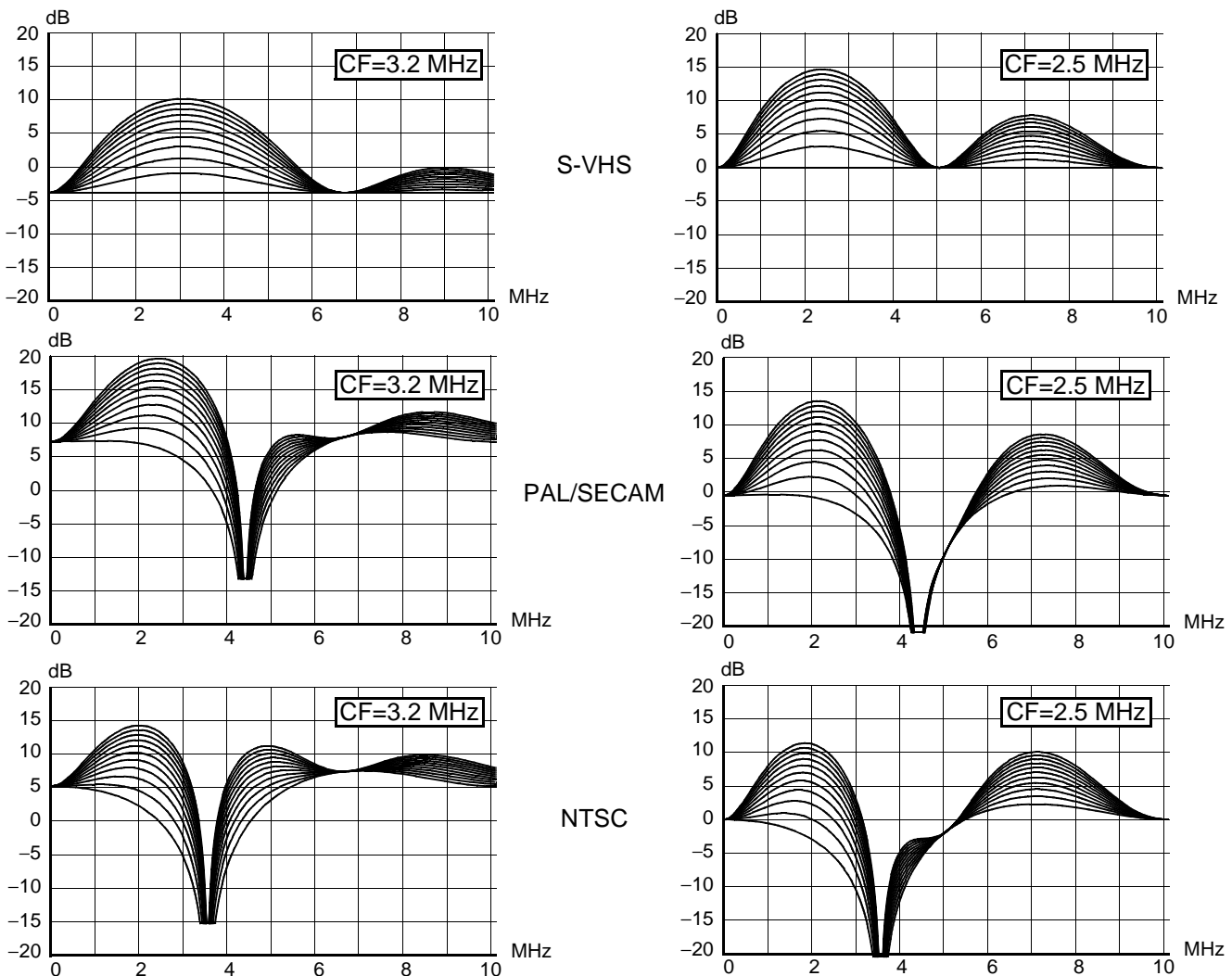

**Fig. 2-13:** Total frequency response for peaking filter and S-VHS, PAL, NTSC



**2.10.4.Digital Brightness Adjustment**

The DC-level of the luminance signal can be adjusted by adding/subtracting an 8-bit number in the luminance signal path in front of the softlimiter.

After the brightness addition, the negative going signals are limited to zero. It is desirable to keep a small positive offset with the signal to prevent undershoots produced by the peaking from being cut.

**2.10.5.Soft Limiter**

The dynamic range of the processed luminance signal must be limited to prevent the CRT from overload. An appropriate headroom for contrast, peaking and brightness can be adjusted by the TV manufacturer according to the CRT characteristics. All signals above this limit will be soft-clipped. A characteristic diagram of the soft limiter is shown in Fig. 2–14. The total limiter consists of three parts:

1. Part 1 includes adjustable tilt point and gain. The gain before the tilt value is 1. Above the tilt value, a part (0...15/16) of the input signal is subtracted from the input signal itself. Therefore the gain is adjustable from 16/16 to 1/16, when the slope value varies from 0 to 15. The tilt value can be adjusted from 0 to 511.
2. Part 2 has the same characteristics as part 1. The subtracting part is also relative to the input signal, so the total differential gain will become negative if the sum of slope 1 and slope 2 is greater than 16 and the input signal is above the both tilt values (see characteristics).
3. Finally, the output signal of the soft limiter will be clipped by a hard limiter adjustable from 256 to 511.

**2.10.6.Chrominance Interpolation**

A linear phase interpolator is used to convert the chrominance sampling rate from 10.125 MHz (4:2:2) to 20.25 MHz (4:4:4). All further processing is carried out at the full sampling rate.

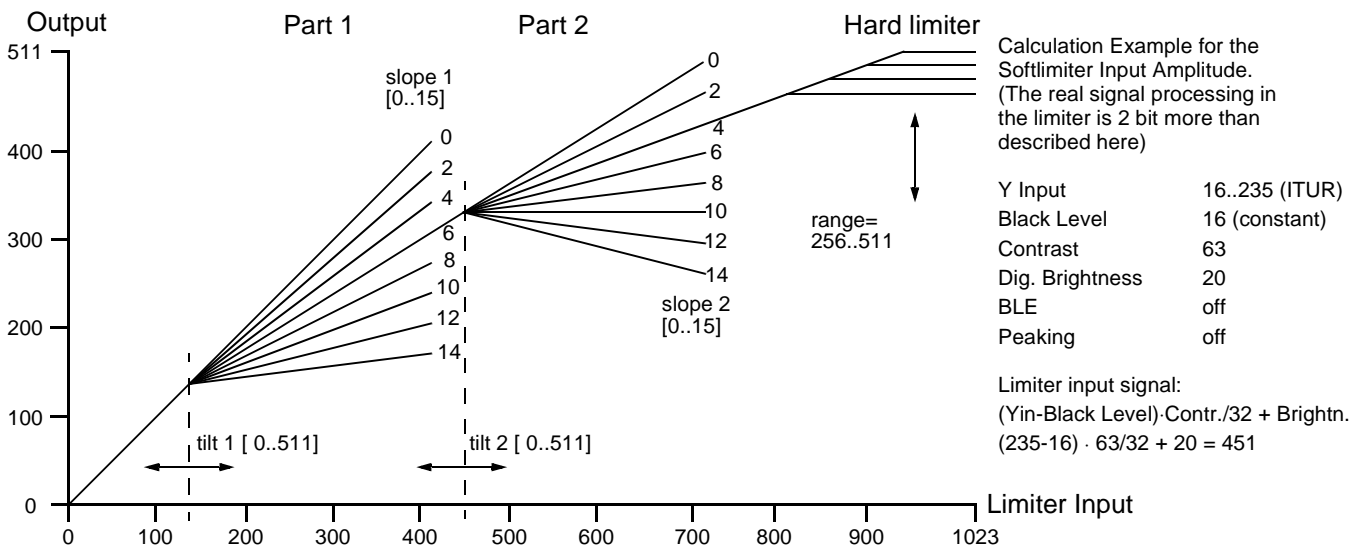

**Fig. 2–14:** Characteristic of soft limiter a and b and hard limiter

**2.10.7. Chrominance Transient Improvement**

The intention of this block is to enhance the chrominance resolution. A correction signal is calculated by differentiation of the color difference signals. The differentiation can be selected according to the signal bandwidth, e.g. for PAL/NTSC/SECAM or digital component signals, respectively. The amplitude of the correction signal is adjustable. Small noise amplitudes in the correction signal are suppressed by an adjustable coring circuit. To eliminate 'wrong colors', which are caused by over and undershoots at the chrominance transition, the sharpened chrominance signals are limited to a proper value automatically.

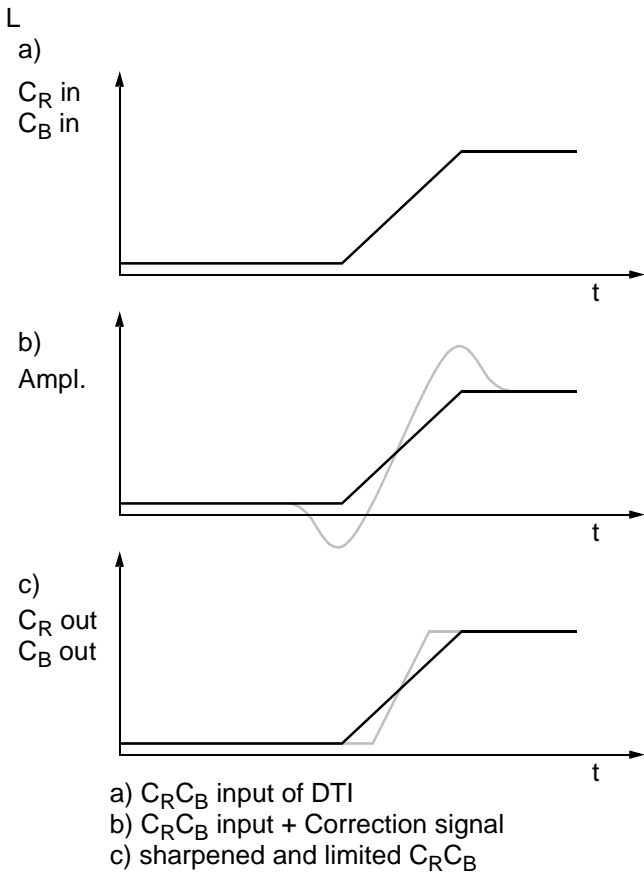

**Fig. 2–15:** Digital Color Transient Improvement

**2.10.8. Inverse Matrix**

A 6-multiplier matrix transcodes the  $C_R$  and  $C_B$  signals to R-Y, B-Y, and G-Y. The multipliers are also used to adjust color saturation in the range of 0 to 2. The coefficients are signed and have a resolution of 9 bits. The matrix computes:

$$\begin{aligned} R-Y &= MR1 \times C_B + MR2 \times C_R \\ G-Y &= MG1 \times C_B + MG2 \times C_R \\ B-Y &= MB1 \times C_B + MB2 \times C_R \end{aligned}$$

The initialization values for the matrix are computed from the standard ITUR (CCIR) matrix:

$$\begin{pmatrix} R \\ G \\ B \end{pmatrix} = \begin{pmatrix} 1 & 0 & 1.402 \\ 1 & -0.345 & -0.713 \\ 1 & 1.773 & 0 \end{pmatrix} \begin{pmatrix} Y \\ C_B \\ C_R \end{pmatrix}$$

For a contrast setting of CTM+32, the matrix values are scaled by a factor of 64 (see Table 2–5 on page 32).

**2.10.9. RGB Processing**

After adding the post-processed luminance, the digital RGB signals are limited to 10 bits. Three multipliers are used to digitally adjust the whitedrive. An average beam current limiter using the same multipliers is implemented (see Section 2.11.1. on page 21).

**2.10.10. Picture Frame Generator**

When the picture does not fill the total screen (height or width too small) it is surrounded with black areas. These areas (and more) can be colored with the picture frame generator. This is done by switching over the RGB signal from the matrix to the signal from the internal picture frame generator.

The width of each area (left, right, upper, lower) can be adjusted separately. The generator starts on the right, respectively lower side of the screen and stops on the left, respectively upper side of the screen. This means, it runs during horizontal, respectively vertical flyback. The color of the complete border can be programmed in the format  $3 \times 4$  bit RGB. The contrast can be adjusted separately.

**2.10.11. Priority Decoder**

The priority decoder selects between the sources video, picture frame and analog RGB (OSD). The picture frame and the OSD can be enabled independently. The priority between picture frame and OSD is selectable. The video source always has the lowest priority. At the transitions between video and the picture frame the peaking transients can be suppressed optionally.

For the video source the black level expander can be activated and a fast switch between 2 settings (main/ side) for contrast, brightness and matrix values is possible.

**2.10.12. Scan Velocity Modulation**

The RGB input signal of the SVM is converted to Y in a simple matrix. Then the Y signal is differentiated by a filter of the transfer function  $1-Z^{-N}$ , where N is programmable from 1 to 6. With a coring, some noise can be suppressed. This is followed by a gain adjustment and an adjustable limiter. The analog output signal is generated by an 8-bit D/A converter.

The signal delay can be adjusted by  $\pm 3.5$  clocks in half-clock steps. For the gain and filter adjustment there are two parameter sets. The switching between these two sets is done with the same RGB switch signal that is used for switching between video-RGB and OSD-RGB for the RGB outputs (see Fig. 2-16).

**2.10.13. Display Phase Shifter**

A phase shifter is used to partially compensate the phase differences between the video source and the flyback signal. By using the described clock system, this phase shifter works with an accuracy of approximately 1 ns. It has a range of 1 clock period which is equivalent to  $\pm 24.7$  ns at 20.25 MHz. The large amount of phase shift (full clock periods) is realized in the front-end circuit.

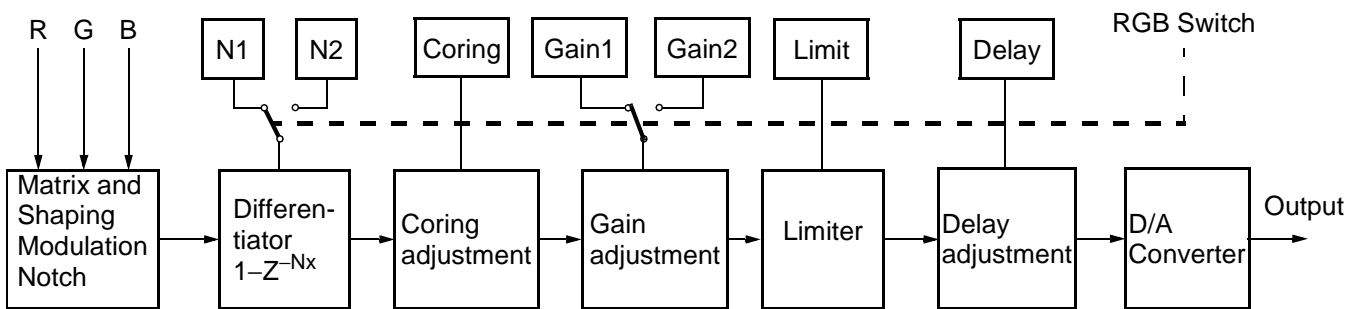

**Fig. 2-16:** SVM Block diagram

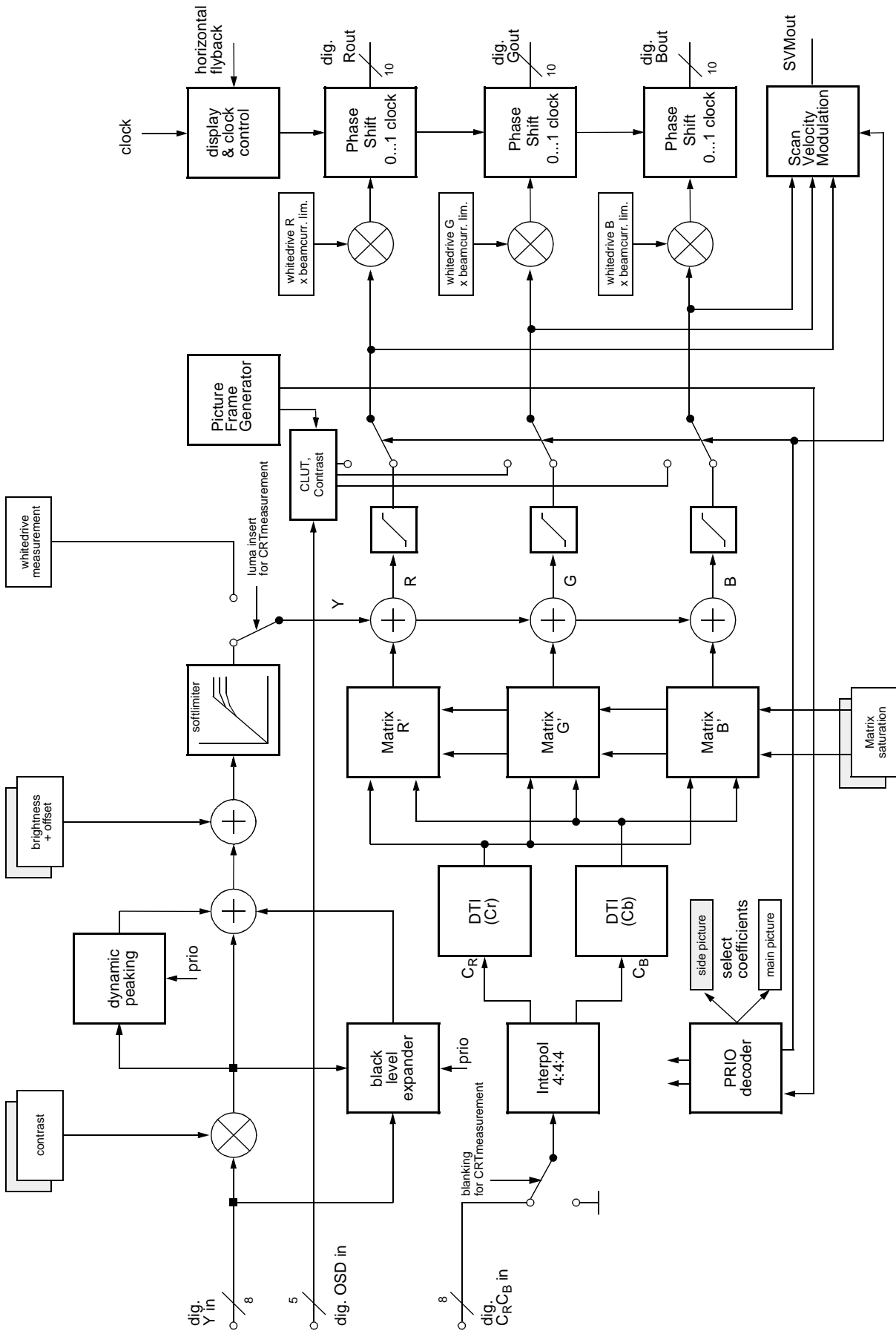

Fig. 2-17: Digital back-end

**2.11.Video Back End**

The digital RGB signals are converted to analog RGBs using three video digital to analog converters (DAC) with 10-bit resolution. An analog brightness value is provided by three additional DACs. The adjustment range is 40 % of the full RGB range.

Controlling the whitedrive/analog brightness and also the external contrast and brightness adjustments is done via the Fast Processor, located in the front-end. Control of the cutoff DACs is via I<sup>2</sup>C-bus registers.

Finally cutoff and blanking values are added to the RGB signals. Cutoff (dark current) is provided by three 9-bit DACs. The adjustment range is 60 % of full scale RGB range.

The analog RGB-outputs are current outputs with current-sink characteristics. The maximum current drawn by the output stage is obtained with peak white RGB. An external half contrast signal can be used to reduce the output current of the RGB outputs to 50 %.

**2.11.1.CRT Measurement and Control**

The display processor is equipped with an 8-bit PDM-ADC for all measuring purposes. The ADC is connected to the sense input pin, the input range is 0 to 1.5 V. The bandwidth of the PDM filter can be selected; it is 40/80 kHz for small/large bandwidth setting. The input impedance is more than 1 MΩ.

Cutoff and whitedrive current measurement are carried out during the vertical blanking interval. They always use the small bandwidth setting. The current range for the cutoff measurement is set by connecting a sense resistor to the MADC input. For the whitedrive measurement, the range is set by using another sense resistor and the range select switch 2 output pin (RSW2). During the active picture, the minimum and maximum beam current is measured. The measurement range can be set by using the range select switch 1 pin (RSW1) as shown in Fig. 2-1 and Fig. 2-18. The timing window of this measurement is programmable. The intention is to automatically detect letterbox transmission or to measure the actual beam current. All control loops are closed via the external control micro-processor.

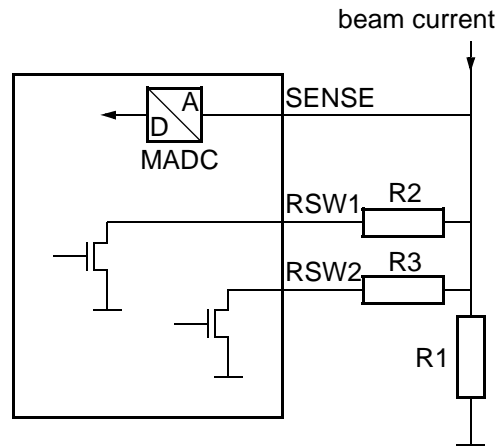

**Fig. 2-1: MADC Range Switches**

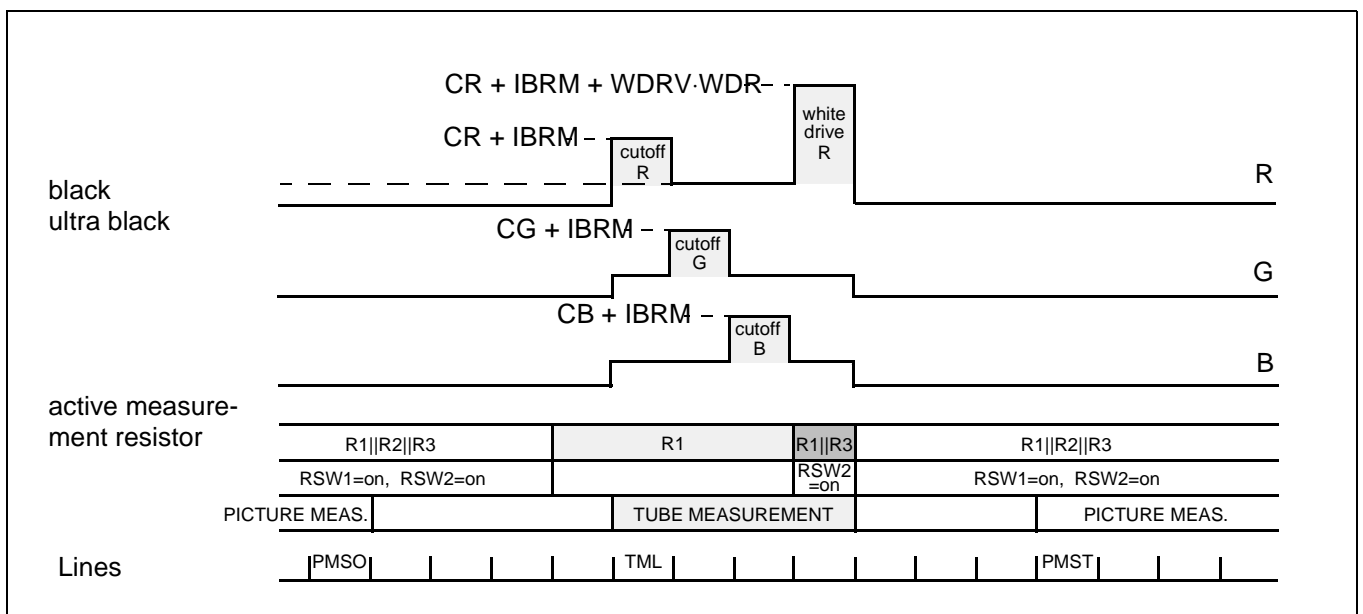

**Fig. 2-18: MADC Measurement Timing**

In each field two sets of measurements can be taken:

- a) The picture tube measurement returns results for
  - cutoff R
  - cutoff G
  - cutoff B
  - whitedrive R or G or B (sequentially)
- b) The picture measurement returns data on
  - active picture maximum current
  - active picture minimum current

The tube measurement is automatically started when the cutoff blue result register is read. Cutoff control for RGB requires one field only while a complete whitedrive control requires three fields. If the measurement mode is set to 'offset check', a measurement cycle is run with the cutoff/whitedrive signals set to zero. This allows to compensate the MADC offset as well as the input the leakage currents. During cutoff and whitedrive measurements, the average beam current limiter function (see Section 2.11.3. on page 23) is switched off and a programmable value is used for the brightness setting. The start line of the tube measurement can be programmed via I<sup>2</sup>C-bus, the first line used for the measurement, i.e. measurement of cutoff red, is 2 lines after the programmed start line.

The picture measurement must be enabled by the control microprocessor after reading the min./max. result registers. If a '1' is written into bit 2 in subaddress 25, the measurement runs for one field. For the next measurement a '1' has to be written again. The measurement is always started at the beginning of active video.

The vertical timing for the picture measurement is programmable, and may even be a single line. Also the signal bandwidth is switchable for the picture measurement.

Two horizontal windows are available for the picture measurement. The large window is active for the entire active line. Tube measurement is always carried out with the small window. Measurement windows for picture and tube measurement are shown in Fig. 2–19.

### 2.11.2. SCART Output Signal

The RGB output of the VDP 313xY can also be used to drive a SCART output. In the case of the SCART signal, the parameter CLMPR (clamping reference) has to be set to 1. Then, during blanking, the RGB outputs are automatically set to 50 % of the maximum brightness. The DC offset values can be adjusted with the cutoff parameters  $C_R$ ,  $C_G$ , and  $C_B$ . The amplitudes can be adjusted with the drive parameters WDR, WDG, and WDB.

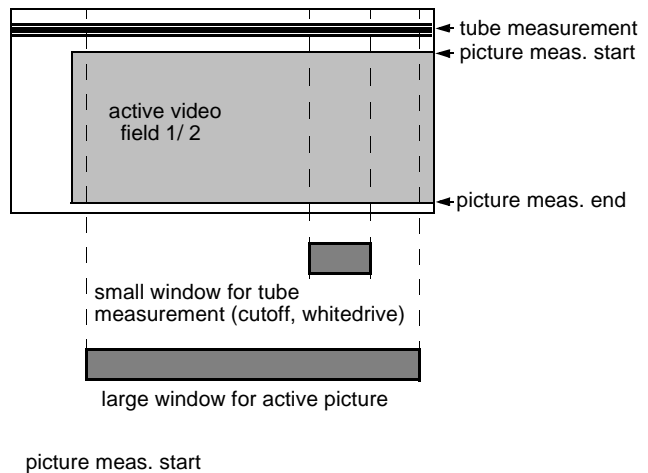

**Fig. 2–19:** Windows for tube and picture measurements

**2.11.3. Average Beam Current Limiter**

The average beam current limiter (BCL) uses the sense input for the beam current measurement. The BCL uses a different filter to average the beam current during the active picture. The filter bandwidth is approx. 2 kHz. The beam current limiter has an automatic offset adjustment that is active two lines before the first cutoff measurement line.

The beam current limiter function is located in the front-end. The data exchange between the front-end and the back-end is done via a single-wire serial interface.

The beam current limiter allows the setting of a threshold current. If the beam current is above the threshold, the excess current is lowpass filtered and used to attenuate the RGB outputs by adjusting the whitedrive multipliers for the internal (digital) RGB signals, and the analog contrast multipliers for the analog RGB inputs, respectively. The lower limit of the attenuator is programmable, thus a minimum contrast can always be set. During the tube measurement, the ABL attenuation is switched off. After the whitedrive measurement line it takes 3 lines to switch back to BCL limited drives and brightness.

Typical characteristics of the ABL for different loop gains are shown in Fig. 2–20; for this example the tube has been assumed to have square law characteristics.

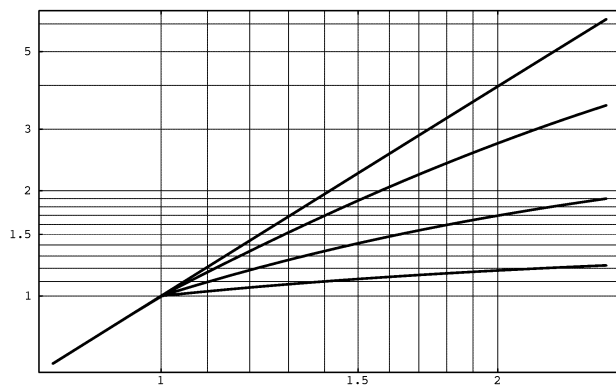

**Fig. 2–20:** Beam current limiter characteristics: beam current output vs. drive  
BCL threshold: 1

**2.11.4. Analog RGB Insertion**

The VDP 313xY allows insertion of 2 external analog RGB signals. Each RGB signal is key-clamped and inserted into the main RGB by the fast blank switch. The selected external RGB input is virtually handled as a priority bus signal. Thus, it can be overlaid or underlaid to the digital picture. The external RGB signals can be adjusted independently as regards DC-level (brightness) and magnitude (contrast).

Which analog RGB input is selected depends on the fast blank input signals and the programming of a number of I<sup>2</sup>C-bus register settings (see Table 2–2 and Fig. 2–21). Both fast blank inputs must be either active-low or active-high.

All signals for analog RGB insertion (RIN1/2, GIN1/2, BIN1/2, FBLIN1/2, HCS) must be synchronized to the horizontal flyback, otherwise a horizontal jitter will be visible. The VDP 313xY has no means for timing correction of the analog RGB input signals.

**Table 2–2:** RGB Input Selection  
FBFOH1=0, FBFOH2=0, FBFOL1=0, FBFOL2=0

FBLIN1	FBLIN2	FBPOL	FBPRIO	RGB output
0	0	0	x	Video
0	1	0	x	RGB input 2
1	0	0	x	RGB input 1
1	1	0	0	RGB input 1
1	1	0	1	RGB input 2
0	0	1	0	RGB input 1
0	0	1	1	RGB input 2
0	1	1	x	RGB input 1
1	0	1	x	RGB input 2
1	1	1	x	Video

**2.11.5. Fast Blank Monitor**

The presence of external analog RGB sources can be detected by means of a fast blank monitor. The status of the selected fast blank input can be monitored via an I<sup>2</sup>C bus register. There is a 2 bit information, giving static and dynamic indication of a fast blank signal. The static bit is directly reading the fast blank input line, whereas the dynamic bit is reading the status of a flip-flop triggered by the negative edge of the fast blank signal.

With this monitor logic it is possible to detect if there is an external RGB source active and if it is a full screen insertion or only a box. The monitor logic is connected directly to the FBLIN1 or FBLIN2 pin. Selection is done via I<sup>2</sup>C bus register.

**2.11.6. Half Contrast Control**

Insertion of transparent text pages or OSD onto the video picture is often difficult to read, especially if the video contrast is high. The VDP 313xY allows contrast reduction of the video background by means of a half contrast input (HCS pin). This input can be supplied with a fast switching signal (similar to the fast blank input), typically defining a rectangular box in which the video picture is displayed with reduced contrast. The analog RGB inputs are still displayed with full contrast.

**2.11.7. IO Port Expander**

The VDP 313xY provides a general purpose IO port to control and monitor up to seven external signals. The port direction is programmable for each bit individually. Via I<sup>2</sup>C bus register it is possible to write or read each port pin. Because of the relatively low I<sup>2</sup>C bus speed, only slow or static signals can be handled.

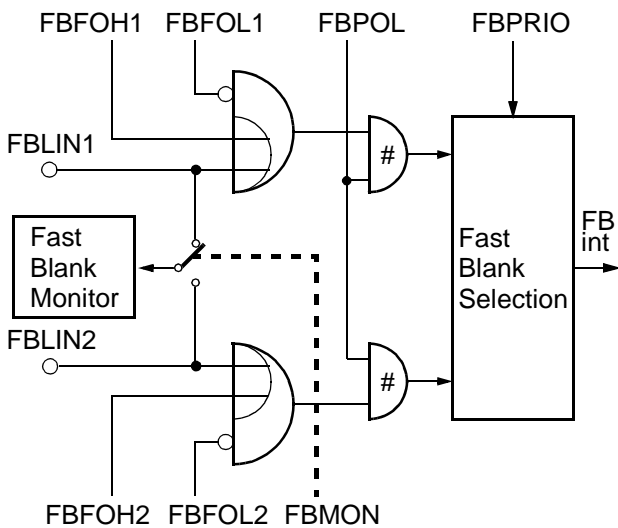

**Fig. 2-21:** Fast Blank Selection Logic

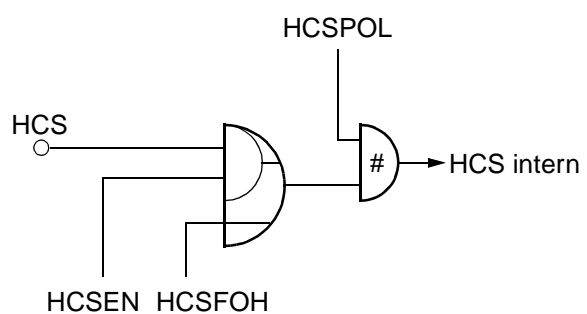

**Fig. 2-22:** Half Contrast Switch Logic



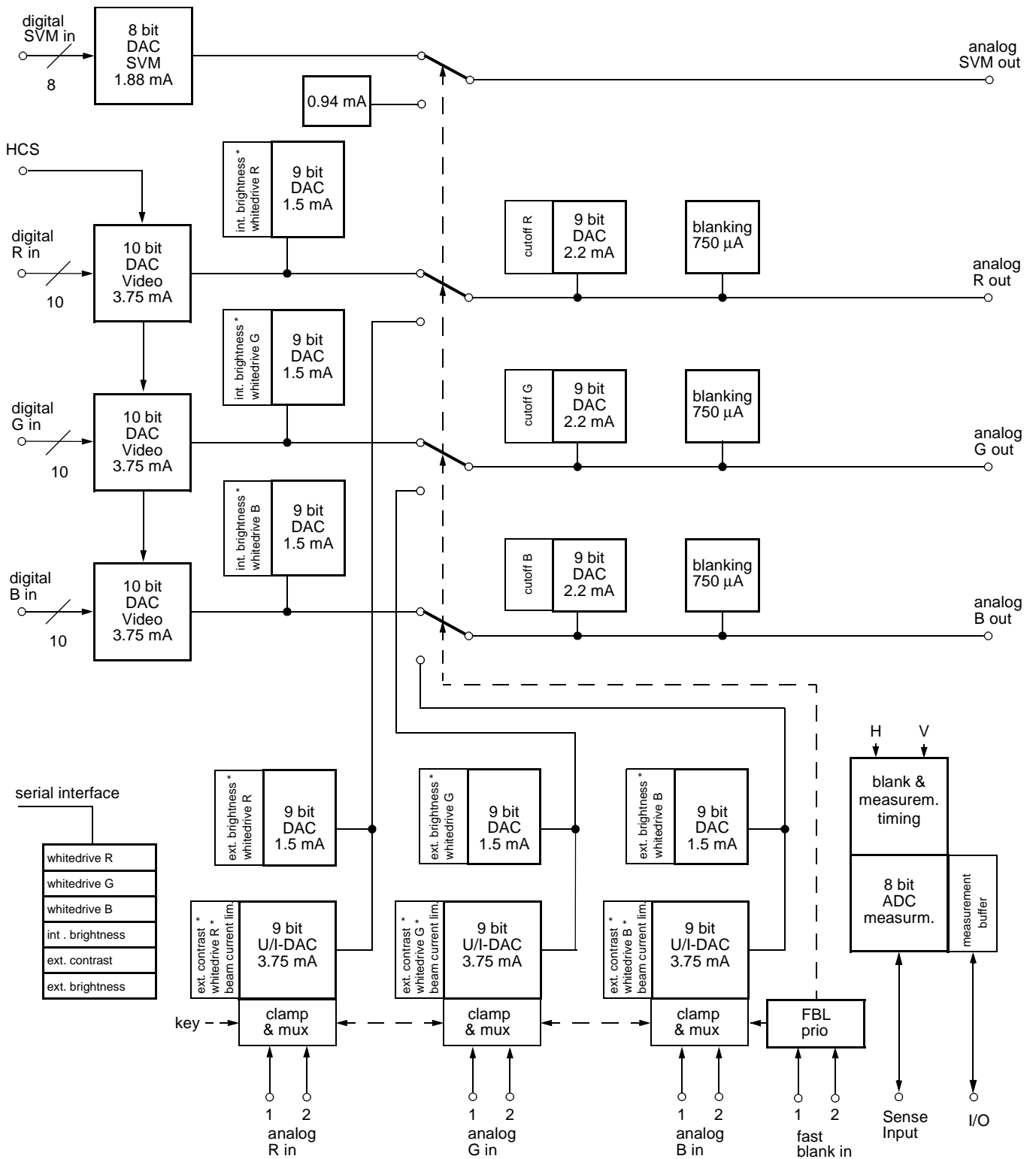

Fig. 2-23: Video back-end

**2.12. Synchronization and Deflection**

The synchronization and deflection processing is distributed over front-end and back-end. The video clamping, horizontal and vertical sync separation and all video related timing information are processed in the front-end. Most of the processing that runs at the horizontal frequency is programmed on the internal Fast Processor (FP). Also the values for vertical and East/West deflection are calculated by the FP software.

The information extracted by the video sync processing is multiplexed onto the hardware front sync signal (FSY) and distributed internally to the rest of the video processing system.

The data for the vertical deflection, the sawtooth and the East/West correction signal is calculated in the front end. The data is transferred to the back-end by a single wire interface.

The display related synchronization, i.e. generation of horizontal and vertical drive and synchronization of horizontal and vertical drive to the video timing

extracted in the front-end, are implemented in hardware in the back-end.

**2.12.1. Deflection Processing**

The deflection processing generates the signals for the horizontal and vertical drive (see Fig. 2–24). This block contains two phase-locked loops:

- PLL2 generates the horizontal and vertical timing, e.g. blanking, clamping and composite sync. Phase and frequency are synchronized by the front sync signal.
- PLL3 adjusts the phase of the horizontal drive pulse and compensates for the delay of the horizontal output stage. Phase and frequency are synchronized by the oscillator signal of PLL2.

The horizontal drive circuitry uses a digital sine wave generator to produce the exact (subclock) timing for the drive pulse. The generator runs at 1 MHz; in the output stage the frequency is divided down to give drive-pulse period and width. The horizontal drive uses an open drain output transistor.

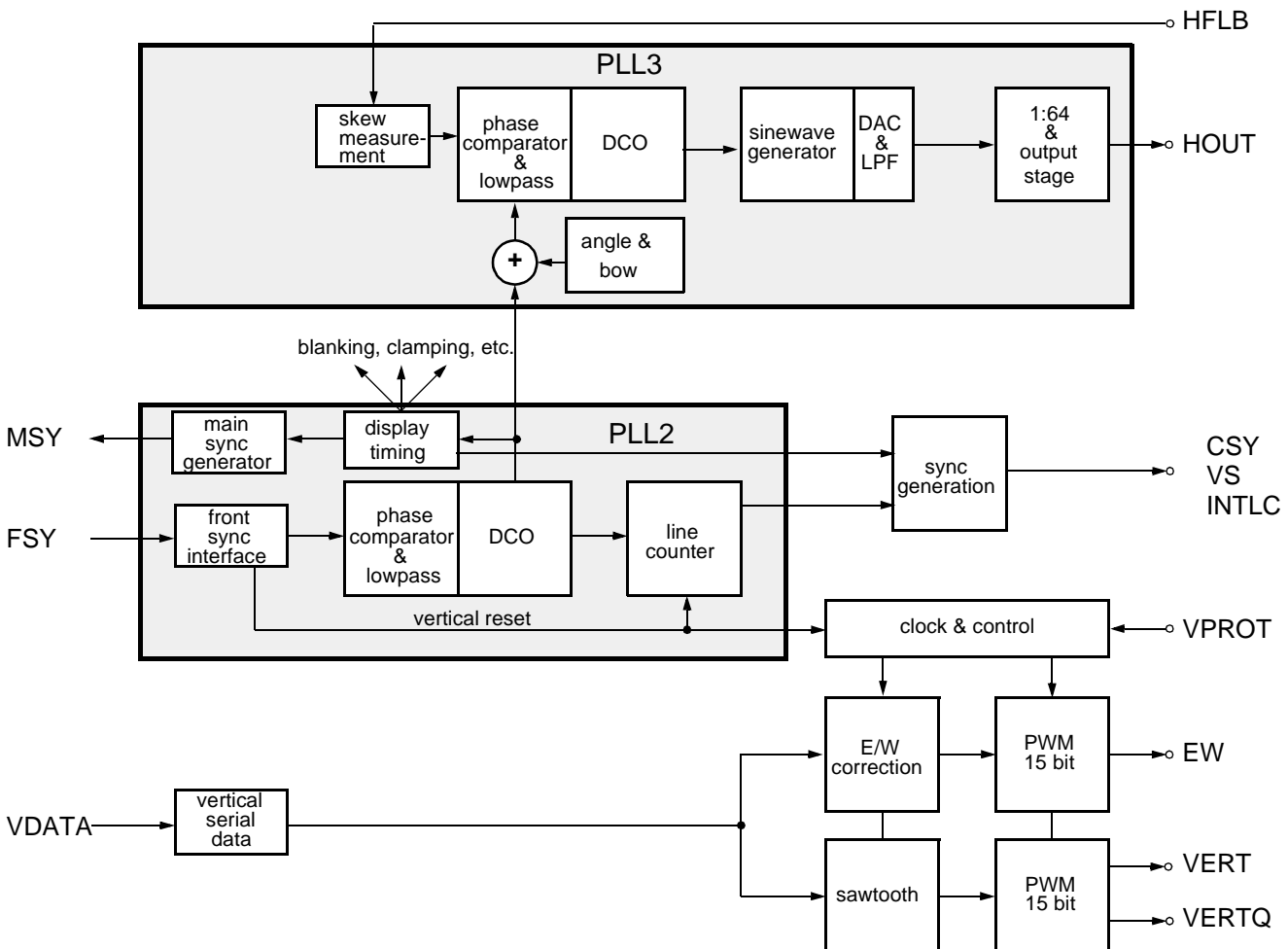

**Fig. 2–24:** Deflection processing block diagram

**2.12.2.Angle & Bow Correction**

The Angle & Bow correction is part of the horizontal drive PLL. This feature allows a shift of the horizontal drive pulse phase depending on the vertical position on the screen. The phase correction has a linear (angle) and a quadratic term (bow).

**2.12.3.Horizontal Phase Adjustment**

This section describes a simple way to align PLL phases and the horizontal frame position.

1. With HDRV the duration of the horizontal drive pulse has to be adjusted
2. With POFS2 the delay between input video and display timing (e.g. clamping pulse for analog RGB) has to be adjusted
3. With CSYDEL the delay between video and analog RGB (OSD) has to be adjusted.
4. With CSYDEL and HPOS the horizontal position of both, the digital and analog RGB signal (from SCART) relative to the clamping pulse has to be adjusted to the correct position, e.g. the pedestal of the generator signal.
5. With POFS3 the position of horizontal drive/flyback relative to RGB has to be adjusted
6. With NEWLIN the position of a scaled video picture can be adjusted (left, middle, center, etc; versions with panorama scaler only).
7. With HBST and HBSO, the start and stop values for the horizontal blanking have to be adjusted.

**Note:** The processing delay of the internal digital video path differs depending on the comb filter option of the VDP 313xY. The versions with comb filter have an additional delay of 34 clock cycles.

**2.12.4.Vertical and East/West Deflection**

The calculations of the vertical and East/West deflection waveforms is done by the internal Fast Processor (FP). The algorithm uses a chain of accumulators to generate the required polynomial waveforms. To produce the deflection waveforms, the accumulators are initialized at the beginning of each field. The initialization values must be computed by the TV control processor and are written to the front-end once. The waveforms are described as polynomials in x, where x varies from 0 to 1 for one field.

$$P: a + b(x-0.5) + c(x-0.5)^2 + d(x-0.5)^3 + e(x-0.5)^4$$

The initialization values for the accumulators a0..a3 for vertical deflection and a0..a4 for East/West deflection are 12-bit values.

Fig. 2–25 shows several vertical and East/West deflection waveforms. The polynomial coefficients are also stated.

In order to get a faster vertical retrace timing, the output impedance of the vertical D/A-converter is reduced during the retrace.

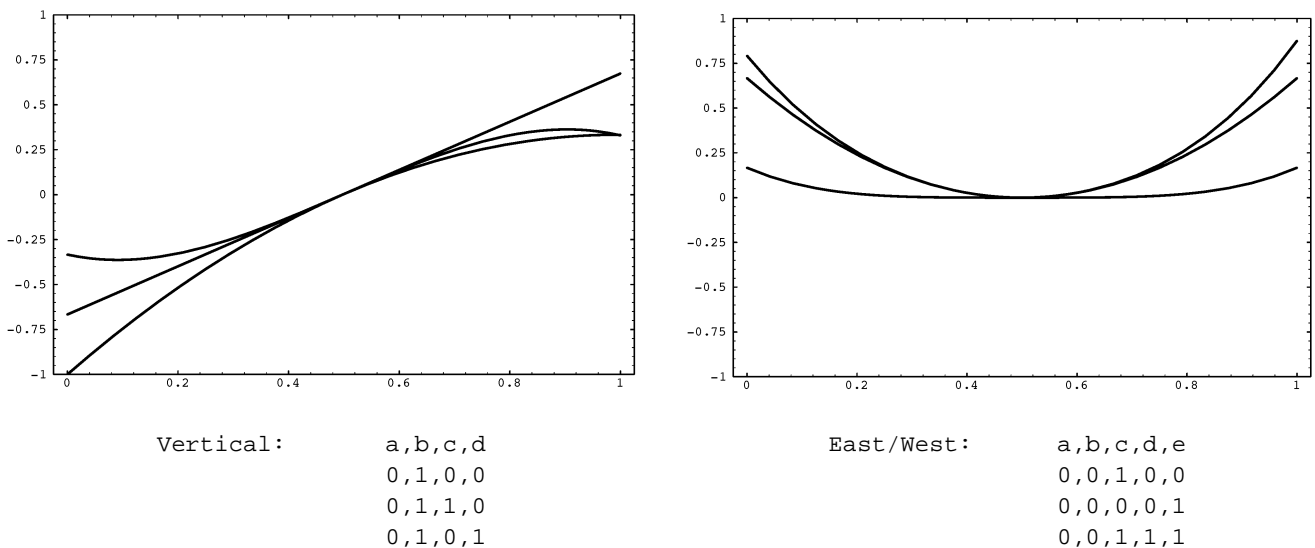

**Fig. 2–25:** Vertical and East/West Deflection Waveforms

### 2.12.5.EHT Compensation

The vertical waveform can be scaled according the average beam current. This is used to compensate the effects of electric high tension changes due to beam current variations. EHT compensation for East/West deflection is done with an offset corresponding to the average beam current.

### 2.12.6.Protection Circuitry

- Picture tube and drive stage protection is provided through the following measures:
- Vertical flyback protection input: this pin searches for a negative edge in every field, otherwise the RGB drive signals are blanked.
- Drive shutoff during flyback: this feature can be selected by software.
- Safety input pin: this input has two thresholds. Between zero and the lower threshold, normal functioning takes place. Between the lower and the higher threshold, the RGB signals are blanked. Above the higher threshold, the RGB signals are blanked and the horizontal drive is shut off. Both thresholds have a small hysteresis.
- The main oscillator and the horizontal drive circuitry are run from a separate (standby) power supply and are already active while the TV set is powering up.

### 2.13.Reset and Power On

Reset of most VDP 313xY functions is performed by the RESQ pin. When this pin becomes active all internal registers and counters are lost. When the RESQ pin is released, the internal reset is still active for 4  $\mu$ s. After that time, the initialization of all required registers is performed by the internal Fast Processor.

The VDP 313xY has clock and voltage supervision circuits to generate a stable HOUT signal. The voltage supervision activates an internal reset signal when the supply for the digital circuits ( $VSUP_D$ ) goes below  $\sim 2.5$  V for more than 50 ns. This reset signal is extended by 50  $\mu$ s after  $VSUP_D$  is back again.

After power on or reset the HOUT generation is switched to a freerunning mode with a fix duty cycle of 50 %. For normal operation the EHPLL bit has to be set first. During the switch the actual period of HOUT can vary by up to 1  $\mu$ s.

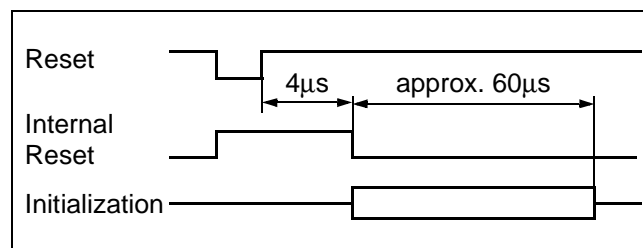

Fig. 2–26: External Reset

2.14. Serial Interface

2.14.1. I<sup>2</sup>C-Bus Interface

Communication between the VDP and the external controller is done via I<sup>2</sup>C-bus. The VDP has two I<sup>2</sup>C-bus slave interfaces (for compatibility with VPC/DDP applications) - one in the front-end and one in the back-end. Both I<sup>2</sup>C-bus interfaces use I<sup>2</sup>C clock synchronization to slow down the interface if required. Both I<sup>2</sup>C-bus interfaces use one level of subaddress: the I<sup>2</sup>C-bus chip address is used to address the IC and a subaddress selects one of the internal registers. The I<sup>2</sup>C-bus chip addresses are given below:

Table 2-3: I<sup>2</sup>C Chip Addresses

Chip Address	A6	A5	A4	A3	A2	A1	A0	R/W
front-end	1	0	0	0	1	1	1	1/0
back-end	1	0	0	0	1	0	1	1/0

The registers of the VDP have 8 or 16-bit data size; 16-bit registers are accessed by reading/writing two 8-bit data words.

Fig. 2-27 shows I<sup>2</sup>C-bus protocols for read and write operations of the interface; the read operation requires an extra start condition and repetition of the chip address with read command set.

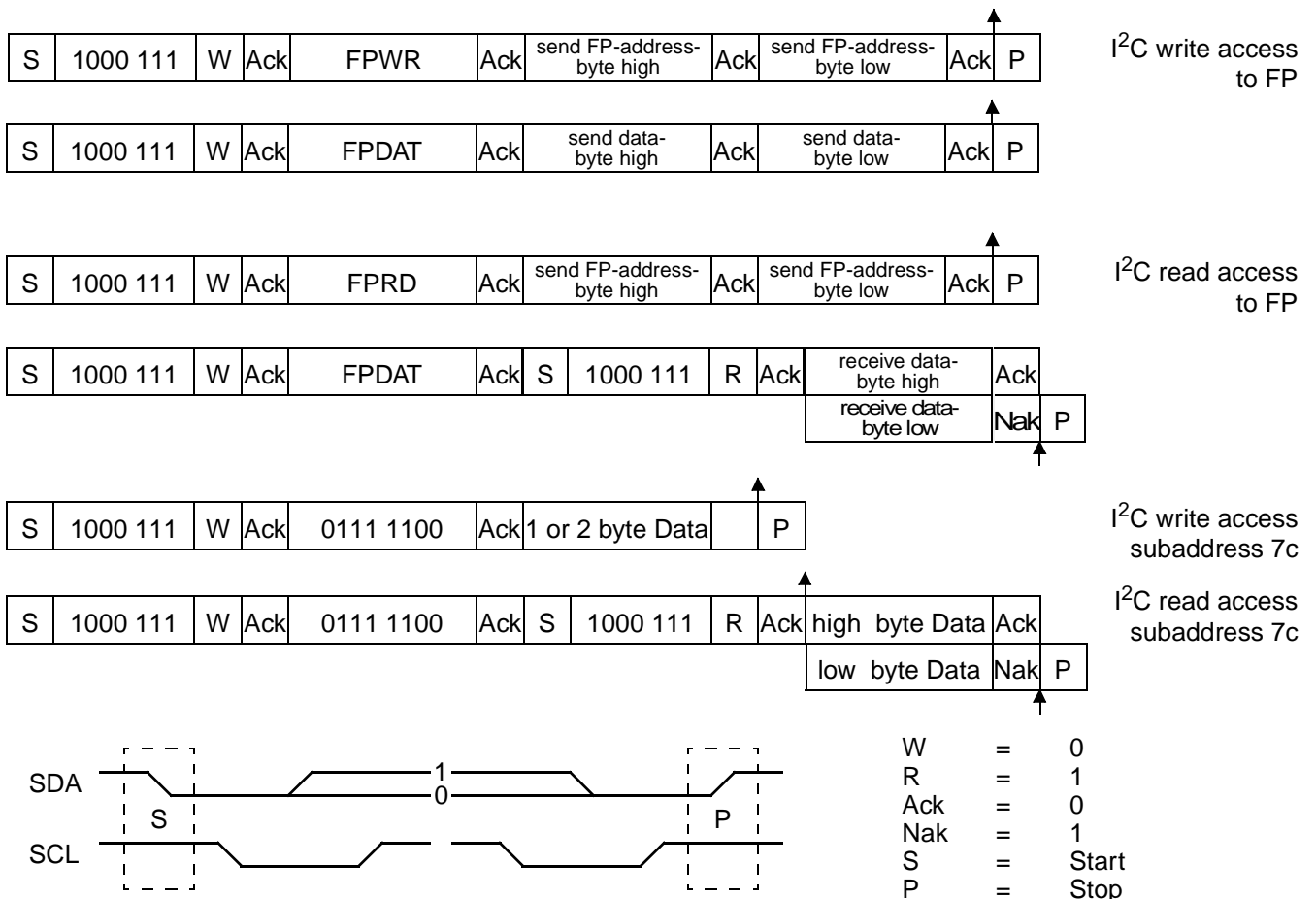

Fig. 2-27: I<sup>2</sup>C-bus protocols

### 2.14.2. Control and Status Registers

Table 2–4 gives definitions of the VDP control and status registers. The number of bits indicated for each register in the table is the number of bits implemented in hardware, i.e. a 9-bit register must always be accessed using two data bytes but the 7 MSB will be 'don't care' on write operations and '0' on read operations. Write registers that can be read back are indicated in Table 2–4.

Functions implemented by software in the on-chip control microprocessor (FP) are explained in Table 2–6.

A hardware reset initializes all control registers to 0. The automatic chip initialization loads a selected set of registers with the default values given in Table 2–4.

The register modes given in Table 2–4 are

- w: write only register
- w/r: write/read data register
- r: read data from VPC
- v: register is latched with vertical sync
- h: register is latched with horizontal sync

**Table 2–4:** I<sup>2</sup>C control and status registers of the video frontend

I <sup>2</sup> C Sub address (hex)	Number of bits	Mode	Function	Default (hex)	Name
<b>FP Interface</b>					
35	8	r	FP status bit[0] write request bit[1] read request bit[2] busy		FPSTA
36	16	w	bit[8:0] 9-bit FP read address bit[11:9] reserved, set to zero		FPRD
37	16	w	bit[8:0] 9-bit FP write address bit[11:9] reserved, set to zero		FPWR
38	16	w/r	bit[11:0] FP data register, reading/writing to this register will autoincrement the FP read/write address. Only 16 bit of data are transferred per I <sup>2</sup> C teleamm.		FPDAT
<b>Black Line Detector</b>					
12	16	r	read only register, do not write to this register! after reading, LOWLIN and UPLIN are reset to 127 to start a new measurement bit[6:0] number of lower black lines bit[7] always 0 bit[14:8] number of upper black lines bit[15] normal/black picture	–	BLKLIN LOWLIN UPLIN BLKPIC

**Table 2–4:** I<sup>2</sup>C control and status registers of the video frontend

I <sup>2</sup> C Sub address (hex)	Number of bits	Mode	Function	Default (hex)	Name
<b>Miscellaneous</b>					
29	16	w/r	Test pattern generator: bit[10:0] reserved (set to 0) bit[11] 0/1 disable/enable test pattern generator bit[13:12] output mode: 00 Y/C = ramp (240 ... 17) 01 Y/C = 16 10 Y/C = 90 11 Y/C = 240 bit[15:14] 0/1 reserved (set to 0)	0 0 0 0	TPG TPGEN TPGMODE
22	16	w/r	NEWLINE (available for versions with panorama scaler only): bit[10:0] NEWLINE register This register defines the readout start of the next line in respect to the value of the sync counter. Value of this register must be greater than 31 for correct operation. bit[15:11] reserved (set to 0)	50	NEWLIN

**Table 2–5:** I<sup>2</sup>C control and status registers of the video backend  
(Registers are set to '0' at reset, default values are recommendations)

I <sup>2</sup> C Sub address (hex)	Number of bits	Mode	Function	Default (hex)	Name
<b>Luminance Channel</b>					
61	9	w v	bit[5:0] 0..63/32 main contrast setting	32	CTM
65	9	w v	bit[5:0] 0..63/32 side contrast setting	32	CTS
51	9	w v	bit[8:0] –256..255 main brightness setting	0	BRM
55	9	w v	bit[8:0] –256..255 side brightness setting	0	BRS
7D	9	w v	bit[7] 0/1 enable/disable black level expander	0	BLE
59	9	w v	black level expander: bit[3:0] 0..15 tilt coefficient bit[8:4] 0...31 amount	8 12	BLE1 BTLT BAM
5D	9	w v	black level expander: bit[8:0] 0..511 disable expansion, threshold value	200	BLE2 BTHR
73	9	w v	black level expander measurement bit[7:0] 0..255 vstart bit[8] 0/1 50/60 Hz measurement windowlength  start line = vstart stop line = 336/283 – vstart (or vertical sync)	0 15	BLE3 BWL BVST
69	9	w v	luma peaking filter, the gain at high frequencies and small signal amplitudes is: $1 + (k1+k2)/8$ bit[3:0] 0..15 k1: peaking level undershoot bit[7:4] 0..15 k2: peaking level overshoot bit[8] 0/1 peaking value normal/inverted (peaking/softening)	4 4 0	PK1 PKUN PKOV PKINV
6D	9	w v	luma peaking filter, coring bit[4:0] 0..31 coring level bit[7:5] reserved bit[8] 0/1 peaking filter center frequency high/low	3 0	PK2 COR PFS
41	9	w v	luma soft limiter, slope A and B bit[3:0] slope segment A bit[7:4] slope segment B	0 0	LSL1 LSLSA LSLSB
45	9	w v	luma soft limiter, absolute limit bit[7:0] luma soft limiter absolute limit (unsigned) bit[8] 0/1 modulation off/on	255 1	LSL2 LSLAL LSLM
4D	9	w v	bit[8:0] luma soft limiter segment A tilt point (unsigned)	250	LSLTA
49	9	w v	bit[8:0] luma soft limiter segment B tilt point (unsigned)	300	LSLTB



**Table 2–5:** I<sup>2</sup>C control and status registers of the video backend  
(Registers are set to '0' at reset, default values are recommendations)

I <sup>2</sup> C Sub address (hex)	Number of bits	Mode	Function	Default (hex)	Name
<b>Chrominance Channel</b>					
14	8	w/r	luma/chroma matching delay bit[2:0] –3...3 variable chroma delay bit[7:3] reserved, set to 0	0	LCM CDEL
5E	9	w v	digital transient improvement bit[3:0] 0..15 coring value bit[7:4] 0..15 DTI gain bit[8] 0/1 narrow/wide bandwidth mode	1 5 1	DTI DTICO DTIGA DTIMO
<b>Inverse Matrix</b>					
7C	9	w v	main matrix coefficient R–Y = MR1M×C <sub>B</sub> +MR2M×C <sub>R</sub> bit[8:0] –256/128 ... 255/128	0	MR1M,
74	9	w v	bit[8:0] –256/128 ... 255/128	86	MR2M
6C	9	w v	main matrix coefficient G–Y = MG1M×C <sub>B</sub> +MG2M×C <sub>R</sub> bit[8:0] –256/128 ... 255/128	–22	MG1M,
64	9	w v	bit[8:0] –256/128 ... 255/128	–44	MG2M
5C	9	w v	main matrix coefficient B–Y = MB1M×C <sub>B</sub> + MB2M×C <sub>R</sub> bit[8:0] –256/128 ... 255/128	113	MB1M,
54	9	w v	bit[8:0] –256/128 ... 255/128	0	MB2M
78	9	w v	side matrix coefficient R–Y = MR1S×C <sub>B</sub> + MR2S×C <sub>R</sub> bit[8:0] –256/128 ... 255/128	0	MR1S,
70	9	w v	bit[8:0] –256/128 ... 255/128	73	MR2S
68	9	w v	side matrix coefficient G–Y = MG1S×C <sub>B</sub> + MG2S×C <sub>R</sub> bit[8:0] –256/128 ... 255/128	–19	MG1S,
60	9	w v	bit[8:0] –256/128 ... 255/128	–37	MG2S
58	9	w v	side matrix coefficient B–Y = MB1S×C <sub>B</sub> + MB2S×C <sub>R</sub> bit[8:0] –256/128 ... 255/128	97	MB1S,
50	9	w v	bit[8:0] –256/128 ... 255/128	0	MB2S

**Table 2-5:** I<sup>2</sup>C control and status registers of the video backend  
(Registers are set to '0' at reset, default values are recommendations)

I <sup>2</sup> C Sub address (hex)	Number of bits	Mode	Function	Default (hex)	Name
<b>Picture Frame Generator</b>					
47	9	w v	bit[7:0] reserved, set to zero bit[8] 1 enable picture frame generator	0	PFGEN
11	16	w h	picture frame color 12 bit wide, bit[3:0] 0..15 blue amplitude bit[7:4] 0..15 green amplitude bit[11:8] 0..15 red amplitude	0 0 0	PFC PFCB PFCG PFCR
4C	9	w v	picture frame insertion contrast for R (ampl. range: 0 to 255) bit[3:0] reserved, set to zero bit[7:4] 0..13 R amplitude = 14,15 PFCR × (PFRCT + 4) invalid	8	PFRCT
48	9	w v	picture frame insertion contrast for G (ampl. range: 0 to 255) bit[3:0] reserved, set to zero bit[7:4] 0..13 G amplitude = 14,15 PFCG × (PFGCT + 4) invalid	8	PFGCT
44	9	w v	picture frame insertion contrast for B (ampl. range: 0 to 255) bit[3:0] reserved, set to zero bit[7:4] 0..13 B amplitude = 14,15 PFCB × (PFBCT + 4) invalid	8	PFBCT
4F	9	w v	bit[8:0] horizontal picture frame begin code 0 = picture frame generator horizontally disabled code 1FF = full frame	0	PFGHB
53	9	w v	bit[8:0] horizontal picture frame end	0	PFGHE
63	9	w v	bit[8:0] vertical picture frame begin code 0 = picture frame generator vertically disabled	270	PFGVB
6F	9	w v	bit[8:0] vertical picture frame end	56	PFGVE
<b>Priority Decoder</b>					
75	9	w v	bit[7] 0/1 select main/side setting for contrast,brightness,matrix	0	SIDE
79	9	w v	bit[7] 0/1 disable/enable peaking transient suppression when signal is switched to the picture frame	0	PKTRNS

**Table 2–5:** I<sup>2</sup>C control and status registers of the video backend  
(Registers are set to '0' at reset, default values are recommendations)

I <sup>2</sup> C Sub address (hex)	Number of bits	Mode	Function	Default (hex)	Name
<b>Scan Velocity Modulation</b>					
5A	9	w v	video mode coefficients bit[5:0] gain1 bit[8:6] differentiator delay 1 (0= filter off, 1...6= delay)	60 4	SVM1 SVG1 SVD1
52	9	w v	limiter bit[6:0] limit value bit[8:5] not used, set to "0"	100 0	SVM3 SVLIM
4E	9	w v	delay and coring bit[3:0] adjustable delay, in 1/2 display clock steps, bit[7:4] coring value bit[8] not used, set to "0"	7 0	SVM4 SVDEL SVCOR
<b>Display Controls</b>					
4A	9	w v	cutoff Red	0	CR
46	9	w v	cutoff Green	0	CG
42	9	w v	cutoff Blue	0	CB

**Table 2–5:** I<sup>2</sup>C control and status registers of the video backend  
(Registers are set to '0' at reset, default values are recommendations)

I <sup>2</sup> C Sub address (hex)	Number of bits	Mode	Function	Default (hex)	Name
<b>Tube- and Picture-Measurements</b>					
7B	9	w v	picture measurement start line bit[8:0] (TML+9)..511 first line of picture measurement	23	PMST
6B	9	w v	picture measurement stop line bit[8:0] (PMST+1)..511 last line of picture measurement	308	PMSO
7F	9	w v	tube measurement line bit[8:0] 0..511 start line for tube measurement	15	TML
25	8	w/r	tube and picture measurement control bit[0] 0/1 disable/enable tube measurement bit[1] 0/1 80/40 kHz bandwidth for picture measurement bit[2] 0/1 disable/enable picture measurement (writing a '1' starts one measurement cycle) bit[3] 0/1 large/small picture measurement window, will be disabled from bit[3] in address h'32 bit[4] 0/1 measure / offset check for adc bit[7:5] reserved	0	PMC TMEN  PMBW  PMEN  PMWIN  OFSEN
13	16	w/r	white drive measurement control bit[9:0] 0..1023 RGB values for white drive beam current measurement bit[10] reserved bit[11] 0/1 RGB values for white drive beam current measurement disabled/enabled	512  0	WDM WDRV  EWDM
18 19 1A 1D 1C 1B	8	r	measurement result registers  minimum in active picture maximum in active picture white drive cutoff/leakage red cutoff/leakage green cutoff/leakage blue, read pulse starts tube measurement	–	MRMIN MRMAX MRWDR MRCR MRCG MRCB

**Table 2–5:** I<sup>2</sup>C control and status registers of the video backend  
(Registers are set to '0' at reset, default values are recommendations)

I <sup>2</sup> C Sub address (hex)	Number of bits	Mode	Function	Default (hex)	Name
1E	8	r	measurement adc status and fast blank input status  measurement status register bit[0] 0/1 tube measurement active / complete  bit[2:1] white drive measurement cycle 00 red 01 green 10 blue 11 reserved  bit[3] 0/1 picture measurement active / complete  bit[4] 0/1 fast blank input low / high (static) bit[5] 1 fast blank input negative transition since last read (bit reset at read)  bit[7:6] reserved	–	PMS
<b>Vertical Timing</b>					
67	9	w v	vertical blanking start bit[8:0] 0..511 first line of vertical blanking	305	VBST
77	9	w v	vertical blanking stop bit[8:0] 0..511 last line of vertical blanking	25	VBSO
5F	9	w v	free running field period bit[8:0] period = (value+4) lines	309	VPER
<b>Horizontal Deflection and Timing</b>					
76	9	w v	linear term of angle & bow correction bit[8:0] –256..+255 ± 500 ns	0	ANGLE
7A	9	w v	quadratic term of angle & bow correction bit[8:0] –256..+255 ± 500 ns	0	BOW
6E	9	w v	adjustable delay of PLL2, clamping, and blanking (relative to front sync) bit[8:0] –256..+255 ± 8 μs	–141	POFS2
72	9	w v	adjustable delay of horizontal drive & flyback (relative to PLL2) bit[8:0] –256..+255 ± 8 μs	0	POFS3
7E	9	w v	adjustable delay of main sync (relative to PLL2) adjust horizontal position for digital picture bit[8:0] 20 steps=1 μs	120	HPOS
5B	9	w v	start of horizontal blanking bit[8:0] 0..511	1	HBST
57	9	w v	end of horizontal blanking bit[8:0] 0..511	48	HBSO

**Table 2–5:** I<sup>2</sup>C control and status registers of the video backend  
(Registers are set to '0' at reset, default values are recommendations)

I <sup>2</sup> C Sub address (hex)	Number of bits	Mode	Function	Default (hex)	Name
62	9	w v	PLL2/3 filter coefficients, 1of5 bit code (n+ set bit number) bit[5:0] proportional coefficient PLL3, $2^{-n-1}$	2	PKP3
66	9	w v	bit[5:0] proportional coefficient PLL2, $2^{-n-1}$	1	PKP2
6A	9	w v	bit[5:0] integral coefficient PLL2, $2^{-n-5}$	2	PKI2
15	16	w/r	horizontal drive and vertical signal control register bit[5:0] 0..63 horizontal drive pulse duration in $\mu$ s (internally limited to 4..61) bit[6] 0/1 disable/enable horizontal PLL2 and PLL3 bit[7] 0/1 1: disable horizontal drive pulse during flyback bit[8] 0/1 reserved, set to '0' bit[9] 0/1 enable/disable ultra black blanking bit[10] 0/1 0: all outputs blanked 1: normal mode bit[11] 0/1 enable/disable clamping for analog RGB input bit[12] 0/1 disable/enable vertical free running mode (FIELD is set to field2, no interlace) bit[13] 0/1 enable/disable vertical protection bit[14] reserved (set to 0) bit[15] 0/1 disable/enable phase shift of display clock	32 0 0 0 0 1 0 0 0 0 1	HVC HDRV EHPLL EFLB DUBL EBL DCRGB SELFT DVPR DISKA
9D	8	w/r	sync output control bit[0] invert INTLC bit[1] disable INTLC (tristateINTLC output) bit[2] invert VS bit[3] disable VS bit[4] disable CSY bit[5] force INTLC to polarity defined in 'INTLCINV'	0	SYCTRL
9E	8	w/r	delay of CSY output (relative to PLL2) bit[7:0] $-128..127 \pm 8 \mu$ s	0	CSYDEL

**Table 2–5:** I<sup>2</sup>C control and status registers of the video backend  
(Registers are set to '0' at reset, default values are recommendations)

I <sup>2</sup> C Sub address (hex)	Number of bits	Mode	Function	Default (hex)	Name
<b>Analog RGB Insertion</b>					
4B	9	w v	bit[7] 0/1 disable/enable analog fast blank input for RGB inserion	0	ERGB
4B	9	w v	bit[0] 0 Picture frame overOSD 1 OSD over picture frame	0	OSDPRI0
32	8	w/r	fast blank interface mode bit[0] 0 internal fast blank 1 from FBLIN1 pin 1 force internal fast blank 1 signal to high bit[1] 0/1 internal fast blank active high/low bit[2] 0/1 disable/enable clamping reference for RGB outputs bit[3] 1 full line MADC measurement window, disables bit [3] in address 25 bit[4] 0/1 horizontal flyback input active high/low bit[6:5] reserved (set to 0) bit[7] 0 internal fast blank 1 from FBLIN1 pin 1 force internal fast blank 1 signal to low	0	FBMOD FBFOH1  FBPOL CLMPR FLMW FLPOL  FBFOL1
31	8	w/r	fast blank interface mode 2 bit[0] 0 internal fast blank 2 from FBLIN2 pin 1 force internal fast blank 2 signal to high bit[1] 0 internal fast blank 2 from FBLIN2 pin 1 force internal fast blank 2signal to low bit[2] fast blank input priority 0 FBLIN1>FBLIN2 1 FBLIN2>FBLIN1 bit[3] fast blank monitor input select 0 monitor connected to FBLIN1 pin 1 monitor connected to FBLIN2 pin bit[4] half contrast switch enable 0/1 HCS disable/enable bit[5] 0 half contrast from HCS pin 1 force half contrast signal to high bit[6] 0/1 half contrast active high/low at HCS pin bit[7] reserved (set to 0)	0	FBMOD2 FBFOH2  FBFOL2  FBPRIO FBMON  HCSEN HCSFOH HCSPOL

**Table 2–5:** I<sup>2</sup>C control and status registers of the video backend  
(Registers are set to '0' at reset, default values are recommendations)

I <sup>2</sup> C Sub address (hex)	Number of bits	Mode	Function	Default (hex)	Name
10	8	w/r	Sync Output bit[5:0] reserved (set to 0) bit[7:6] function of CSY pin 00 composite sync signal output 01 25 Hz output (field1/field2 signal) 10 horizontal sync signal output 11 1 MHz horizontal drive clock	0	CSYM
<b>Ports</b>					
34	16	w/r	IO Port bit[6:0] data to/from PORT[6:0] bit[7] reserved (set to 0) bit[14:8] port direction 0 switch PORT[bit–8] to input 1 switch PORT[bit–8] to output bit[15] reserved (set to 0)	0	IOPORT IODATA  IODIR
<b>Hardware ID</b>					
9F	16	r	Hardware version number bit[7:0] hardware id (A3 = 13, B1 = 21 a.s.o.) bit[15:8] product code VDP 31xx Y (e.g. 32 for VDP 3132 Y)	read only	HWID



**Table 2–6:** Control Registers of the Fast Processor for control of the video frontend functions  
 –default values are initialized at reset

FP Sub-address (hex)	Function	Default (hex)	Name
<b>Standard Selection</b>			
20	Standard select: bit[2:0]    standard 0    PAL B,G,H,I (50 Hz)    4.433618 1    NTSC M        (60 Hz)    3.579545 2    SECAM        (50 Hz)    4.286 3    NTSC44        (60 Hz)    4.433618 4    PAL M        (60 Hz)    3.575611 5    PAL N        (50 Hz)    3.582056 6    PAL 60        (60 Hz)    4.433618 7    NTSC COMB (60 Hz)    3.579545  bit[3]        0/1    standard modifier PAL modified to simple PAL NTSC modified to compensated NTSC SECAM modified to monochrome 625 NTSCC modified to monochrome 525  bit[4]        reserved (set to 0) bit[5]        0/1    2-H comb filter off/on bit[6]        0/1    S-VHS mode off/on (2-H comb is switched off)  Option bits allow to suppress parts of the initialization, this can be used for color standard search: bit[7]        no hpll setup bit[8]        no vertical setup bit[9]        no acc setup bit[10]       2-H comb filter set-up only bit[11]       status bit, normally write 0. After the FP has switched to a new standard, this bit is set to 1 to indicate operation complete. Standard is automatically initialized when the insel register is written.	0	STD  PAL NTSC SECAM NTSC44 PALM PALN PAL60 NTSCC  SDTMOD   COMB SVHS  SDTOPT

**Table 2–6:** Control Registers of the Fast Processor for control of the video frontend functions  
–default values are initialized at reset

FP Sub-address (hex)	Function	Default (hex)	Name
148	Enable automatic standard recognition (ASR) bit[0] 0/1 PAL B,G,H,I (50 Hz) 4.433618 bit[1] 0/1 NTSC M (60 Hz) 3.579545 bit[2] 0/1 SECAM (50 Hz) 4.286 bit[3] 0/1 NTSC44 (60 Hz) 4.433618 bit[4] 0/1 PAL M (60 Hz) 3.575611 bit[5] 0/1 PAL N (50 Hz) 3.582056 bit[6] 0/1 PAL 60 (60 Hz) 4.433618 bit[10:7] reserved set to 0 bit[11] 1 reset status information 'switch' in asr_status (cleared automatically)  0: disable recognition; 1: enable recognition  <b>Note:</b> For correct operation don't change FP reg. 20h and 21h, while ASR is enabled!	0	ASR_ENA
14E	Status of automatic standard recognition bit[0] 1 error of the vertical standard (neither 50 nor 60 Hz) bit[1] 1 detected standard is disabled bit[2] 1 search active bit[3] 1 search terminated, but failed bit[4] 1 no color found bit[5] 1 standard has been switched (since last reset of this flag with bit[11] of asr_enable)  bit[4:0] 00000 all ok 00001 search not started, because vwin error detected (no input or SECAM L) 00010 search not started, because detected vert. standard not enabled 0x1x0 search started and still active 01x00 search failed (found standard not correct) 01x10 search failed, (detected color standard not enabled) 1000 no color found (monochrome input or switch betw. CVBS/SVHS necessary)	0	ASR_STATUS VWINERR  DISABLED BUSY FAILED NOCOLOR SWITCH
22	picture start position, this register sets the start point of active video, this can be used e.g. for panning. The setting is updated when 'sdt' register is updated.	0	SFIF

**Table 2–6:** Control Registers of the Fast Processor for control of the video frontend functions  
–default values are initialized at reset

FP Sub-address (hex)	Function	Default (hex)	Name
23	luma/chroma delay adjust. The setting is updated when 'sdt' register is updated.  bit[5:0] reserved, set to zero bit[11:6] luma delay in clocks, allowed range is +1...–7	0	LDLY
21	Input select: writing to this register will also initialize the standard  bit[1:0] luma selector 00 VIN1 01 VIN2 10 VIN3 11 VIN4  bit[2] chroma selector 0 CIN1 1 CIN2  bit[4:3] IF compensation 00 off 01 6 dB/Okt 10 12 dB/Okt 11 10 dB/MHz only for SECAM  bit[6:5] chroma bandwidth selector 00 narrow 01 normal 10 broad 11 wide  bit[7] 0/1 adaptive/fixed SECAM notch filter bit[8] 0/1 enable luma lowpass filter bit[10:9] hpll speed 00 no change 01 terrestrial 10 vcr 11 mixed  bit[11] status bit, write 0, this bit is set to 1 to indicate operation complete.	00  0  00  01	INSEL  VIS  CIS  IFC  CBW  FNTCH LOWP HPLLMD

**Table 2–6:** Control Registers of the Fast Processor for control of the video frontend functions  
–default values are initialized at reset

FP Sub-address (hex)	Function	Default (hex)	Name
2F	<p>YC<sub>R</sub>C<sub>B</sub> mode control register</p> <p>bit[6:0] reserved (set to 0)</p> <p>bit[7] 1 ADC over-/underflow (has to be reset after read if used)</p> <p>bit[8] 0 disable YC<sub>R</sub>C<sub>B</sub> 1 enable YC<sub>R</sub>C<sub>B</sub></p> <p>bit[9] ADC range 0 nominal input amplitude (±350 mV) 1 extended input amplitude (±500 mV)</p> <p>bit[11:10] reserved (set to 0)</p> <p>Note: Activate the YC<sub>R</sub>C<sub>B</sub> mode by</p> <ul style="list-style-type: none"> <li>- enabling YC<sub>R</sub>C<sub>B</sub></li> <li>- selecting simple PAL or NTSC M, svhs=1, comb=0 in the std register</li> <li>- setting cbw=2 in the insel register</li> </ul>	0	YCRCB
<b>Comb Filter</b>			
27	<p>comb filter control register</p> <p>bit[0] 0 comb coefficients are calculated for luma/ chroma 1 comb coefficients for luma are used for luma and chroma</p> <p>bit[1] 0 luma comb strength depends on signal amplitude 1 luma comb strength is independent of amplitude</p> <p>bit[2] 0 max comb booster 1 reduced comb booster</p> <p>bit[4:3] 0..3 comb strength for chroma signal</p> <p>bit[6:5] 0..3 comb strength for luma signal</p> <p>bit[11:7] 0..31 overall limitation of the calculated comb coefficients 0 no limitation 31 max limitation (1/2)</p>	<p>0</p> <p>0</p> <p>1</p> <p>3</p> <p>2</p> <p>0</p>	<p>CMB_UC</p> <p>CC</p> <p>DAA</p> <p>KB</p> <p>KC</p> <p>KY</p> <p>CLIM</p>

**Table 2–6:** Control Registers of the Fast Processor for control of the video frontend functions  
–default values are initialized at reset

FP Sub-address (hex)	Function	Default (hex)	Name
<b>Color Processing</b>			
30	Saturation control bit[11:0] 0...4094 (2070 corresponds to 100% saturation) 4095 disabled (test mode only)	2070	ACC_SAT
17A	bit[10:0] 0...2047 CR-attenuation bit[11] 0/1 disable/enable CR-attenuation	1591 0	CR_ATT CR_ATT_ENA
39	bit[10:0] 0...2047 amplitude killer level (0: killer disabled) bit[11] 0/1 disable/enable chroma ADC	25 0	KILVL
3A	amplitude killer hysteresis	5	KILHY
DC	NTSC tint angle, $\pm 512 = \pm \pi/4$	0	TINT
<b>DVCO</b>			
F8	crystal oscillator center frequency adjust, –2048...2047	–720	DVCO
F9	crystal oscillator center frequency adjustment value for line lock mode, true adjust value is DVCO - ADJUST.  For factory crystal alignment, using standard video signal: set DVCO = 0, set lock mode, read crystal offset from ADJUST register and use negative value for initial center frequency adjustment via DVCO.	read only	ADJUST
F7	crystal oscillator line-locked mode, lock command/status  write: 100 enable lock 0 disable lock read: 0 unlocked >2047 locked	0	XLCK
B5	crystal oscillator line-locked mode, autolock feature. If autolock is enabled, crystal oscillator locking is started automatically. bit[11:0] threshold; 0: autolock off	400	AUTOLOCK

**Table 2–6:** Control Registers of the Fast Processor for control of the video frontend functions  
–default values are initialized at reset

FP Sub-address (hex)	Function	Default (hex)	Name
<b>FP Status Register</b>			
12	general purpose control bits bit[2:0] reserved, do not change bit[3] vertical standard force bit[8:4] reserved, do not change bit[9] disable flywheel interlace bit[11:10] reserved, do not change to enable vertical free run mode set vfrc to 1 and dflw to 0	0  1	GPC  VFRC  DFLW
13	standard recognition status (see also: 'automatic standard recognition') bit[0] 1 vertical lock bit[1] 1 horizontally locked bit[2] no signal detected bit[3] 1 color amplitude killer active bit[4] 1 disable amplitude killer bit[5] 1 color ident killer active bit[6] 1 disable ident killer bit[7] 1 interlace detected bit[8] 1 no vertical sync detection bit[9] 1 spurious vertical sync detection bit[11:10] reserved	–	ASR
14	input noise level	read only	NOISE
CB	number of lines per field, P/S: 312, N: 262	read only	NLPF
15	vertical field counter, incremented per field		VCNT
74	measured sync amplitude value, nominal: 768 (PAL), 732 (NTSC)	read only	SAMPL
36	measured burst amplitude	read only	BAMPL
F0	firmware version number bit[7:0] internal revision number bit[11:8] firmware release	read only	SW_VERSION
170	status of macrovision detection bit[0] AGC pulse detected bit[1] pseudo sync detected	read only	MCV_STATUS

**Table 2–6:** Control Registers of the Fast Processor for control of the video frontend functions  
–default values are initialized at reset

FP Sub-address (hex)	Function	Default (hex)	Name
171	bit[11:0] first line of macrovision detection window (relative to vsync)	6	MCV_START
172	bit[11:0] last line of macrovision detection window (relative to vsync)	15	MCV_STOP
<b>Scaler Control Register</b>			
40	<p>scaler mode register</p> <p>bit[1:0] scaler mode</p> <p>0 linear scaling mode</p> <p>1 nonlinear scaling mode, 'panorama'</p> <p>2 nonlinear scaling mode, 'waterglass'</p> <p>3 reserved</p> <p>bit[10:2] reserved, set to 0</p> <p>bit[11] scaler update</p> <p>0 start scaler update command, when the registers are updated the bit is set to 1</p>	0	SCMODE MODE  SCUP
41	<p>luma offset register</p> <p>bit[6:0] luma offset 0..127</p> <p>ITU-R output format: 57</p> <p>CVBS output format: 4</p> <p>this register is updated when the scaler mode register is written</p>	57	YOFFS
42	<p>active video length for 1-h FIFO</p> <p>bit[11:0] length in pixels</p> <p>this register is updated when the scaler mode register is written</p>	1080	FFLIM
43	<p>scaler1 coefficient, this scaler is compressing the signal.</p> <p>For compression by a factor c the value <math>c*1024</math> is required.</p> <p>bit[11:0] allowed values from 1024..4095</p> <p>this register is updated when the scaler mode register is written</p>	1024	SCINC1
44	<p>scaler2 coefficient, this scaler is expanding the signal.</p> <p>For expansion by a factor c the value <math>1/c*1024</math> is required.</p> <p>bit[11:0] allowed values from 256..1024</p> <p>this register is updated when the scaler mode register is written</p>	1024	SCINC2
45	<p>scaler1/2 nonlinear scaling coefficient</p> <p>this register is updated when the scaler mode register is written</p>	0	SCINC
47 - 4B	<p>scaler1 window controls, see table</p> <p>5 12-bit registers for control of the nonlinear scaling</p> <p>this register is updated when the scaler mode register is written</p>	0	SCW1_0 - 4

**Table 2–6:** Control Registers of the Fast Processor for control of the video frontend functions  
–default values are initialized at reset

FP Sub-address (hex)	Function	Default (hex)	Name
4C - 50	scaler2 window controls see table 5 12-bit registers for control of the nonlinear scaling this register is updated when the scaler mode register is written	0	SCW2_0 - 4

### 2.14.2.1. Scaler Adjustment

In case of linear scaling, most of the scaler registers need not be set. Only the scaler mode, active video length, and the fixed scaler increments (scinc1/scinc2) must be written.

The adjustment of the scaler for nonlinear scaling modes should use the parameters given in Table 2–7.

**Table 2–7:** Set-up values for nonlinear scaler modes

Register	Scaler Modes			
	'waterglass' border 35%		'panorama' border 30%	
	center compression			
	3/4	5/6	4/3	6/5
scinc1	1643	1427	1024	1024
scinc2	1024	1024	376	611
scinc	90	56	85	56
fflim	945	985	921	983
scw1 - 0	110	115	83	94
scw1 - 1	156	166	147	153
scw1 - 2	317	327	314	339
scw1 - 3	363	378	378	398
scw1 - 4	473	493	461	492
scw2 - 0	110	115	122	118
scw2 - 1	156	166	186	177
scw2 - 2	384	374	354	363
scw2 - 3	430	425	418	422
scw2 - 4	540	540	540	540



**Table 2–8:** Control Registers of the Fast Processor for control of the video backend functions—default values are initialized at reset

FP Sub-address (hex)	Function	Default (hex)	Name
<b>FP Display Control Register</b>			
130	White Drive Red (0...1023)	700	WDR <sup>1)</sup>
131	White Drive Green (0...1023)	700	WDG <sup>1)</sup>
132	White Drive Blue (0...1023)	700	WDB <sup>1)</sup>
139	Internal Brightness, Picture (0...511), the center value is 256, the range allows for both increase and reduction of brightness.	256	IBR
13C	Internal Brightness, Measurement (0...511), the center value is 256, the brightness for measurement can be set to measure at higher cutoff current. The measurement brightness is independent of the drive values.	256	IBRM
13A	Analog Brightness for external RGB (0...511), the center value is 256, the range allows for both increase and reduction of brightness.	256	ABR
13B	Analog Contrast for external RGB (0...511)	350	ACT
<sup>1)</sup> The white drive values will become active only after writing the blue value WDB, latching of new values is indicated by setting the MSB of WDB.			
<b>FP Display Control Register, BCL</b>			
144	BCL threshold current, 0...2047 (max ADC output ~1152)	1000	BCLTHR
142	BCL time constant 0...15 → 13 ... 1700 ms	15	BCLTM
143	BCL loop gain. 0..15	0	BCLG
145	BCL minimum contrast 0...1023	307	BCLMIN
105	Test register for BCL/EHT comp. function, register value: 0 normal operation 1 stop ADC offset compensation x>1 use x in place of input from Measurement ADC	0	BCLTST
60	Current BCL reduction (0...1023; read only)	1023	BCLREDUC
<b>FP Display Control Register, Deflection</b>			
103	interlace offset, -2048..2047 This value is added to the SAWTOOTH output during one field.	0	INTLC
102	discharge sample count for deflection retrace, SAWTOOTH DAC output impedance is reduced for DSCC lines after vertical retrace.	7	DSCC
11F	vertical discharge value, SAWTOOTH output value during discharge operation, typically same as A0 init value for sawtooth.	-1365	DSCV
10B	EHT compensation vertical gain coefficient, 0...511	0	EHTV

**Table 2–8:** Control Registers of the Fast Processor for control of the video backend functions—default values are initialized at reset

FP Sub-address (hex)	Function	Default (hex)	Name
10A	EHT compensation time constant, 0...15 → 3.2..410 ms	15	EHTTM
10F	EHT compensation east/west gain coefficient, –512...511	0	EHTEW
<b>FP Display Control Register, Vertical Sawtooth</b>			
110	DC offset of SAWTOOTH output This offset is independent of EHT compensation.	0	OFS
11B	accu0 init value	–1365	A0
11C	accu1 init value	900	A1
11D	accu2 init value	0	A2
11E	accu3 init value	0	A3
<b>FP Display Control Register, East-West Parabola</b>			
12B	accu0 init value	–1121	A0
12C	accu1 init value	219	A1
12D	accu2 init value	479	A2
12E	accu3 init value	–1416	A3
12F	accu4 init value	1052	A4

**2.14.2.2. Calculation of Vertical and East-West Deflection Coefficients**

In Table 2–9 and Table 2–10 the formula for the calculation of the deflection initialization parameters from the polynomial coefficients a,b,c,d,e is given for the vertical and East-West deflection. Let the polynomial be

$$P : a + b(x - 0.5) + c(x - 0.5)^2 + d(x - 0.5)^3 + e(x - 0.5)^4$$

The initialization values for the accumulators a0..a3 for vertical deflection and a0..a4 for East-West deflection are 12-bit values. The coefficients that should be used to calculate the initialization values for different field frequencies are given below, the values must be scaled by 128, i.e. the value for a0 of the 50 Hz vertical deflection is:

$$a0 = (a \cdot 128 - b \cdot 1365.3 + c \cdot 682.7 - d \cdot 682.7) / 128$$

**Table 2–9:** Calculation of Initialization values for Vertical Sawtooth

Vertical Deflection 50 Hz				
	a	b	c	d
a0	128	-1365.3	682.7	-682.7
a1		899.6	-904.3	1363.4
a2			296.4	-898.4
a3				585.9
Vertical Deflection 60 Hz				
	a	b	c	d
a0	128	-1365.3	682.7	-682.7
a1		1083.5	-1090.2	1645.5
a2			429.9	-1305.8
a3				1023.5

**Table 2–10:** Calculation of Initialization values for East-West Parabola

East-West Deflection 50 Hz					
	a	b	c	d	e
a0	128	-341.3	1365.3	-85.3	341.3
a1		111.9	-899.6	84.8	-454.5
a2			586.8	-111.1	898.3
a3				72.1	-1171.7
a4					756.5
East-West Deflection 60 Hz					
	a	b	c	d	e
a0	128	-341.3	1365.3	-85.3	341.3
a1		134.6	-1083.5	102.2	-548.4
a2			849.3	-161.2	1305.5
a3				125.6	-2046.6
a4					1584.8

### 3. Specifications

#### 3.1. Outline Dimensions

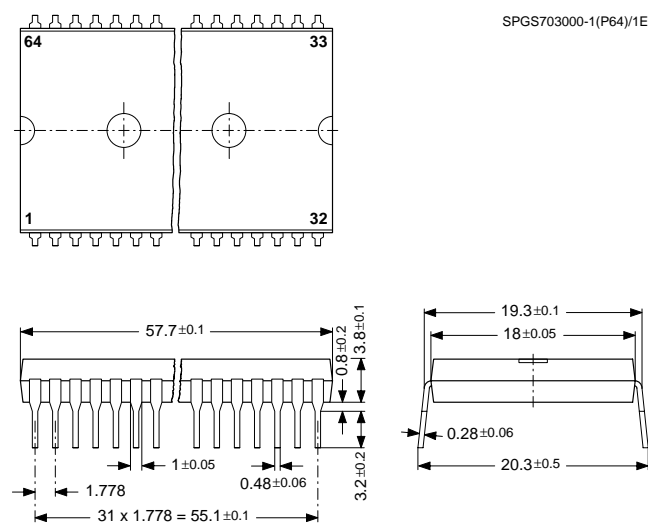

**Fig. 3-1:**  
64-Pin Plastic Shrink Dual-Inline Package  
(PSDIP64)  
Weight approximately 9.0 g  
Dimensions in mm

#### 3.2. Pin Connections and Short Descriptions

NC = not connected  
LV = if not used, leave vacant

X = obligatory; connect as described in circuit diagram

IN = Input  
OUT = Output  
SUPPLY = Supply Pin

Pin No. PSDIP 64-pin	Pin Name	Type	Connection (If not used)	Short Description
1	TEST	IN	GNDD	Test Input
2	RESQ	IN	X	Reset Input
3	SCL	IN/OUT	X	I <sup>2</sup> C Bus Clock
4	SDA	IN/OUT	X	I <sup>2</sup> C Bus Data
5	GNDD	SUPPLY	X	Digital Ground
6	HCS	IN	LV	Half Contrast Switch Input
7	FSY	OUT	LV	Front Sync Output
8	CSY	OUT	LV	Composite Sync Output
9	VS	OUT	LV	Vertical Sync Output (= VS Bit of MSY for TPU)
10	INTLC	OUT	LV	Interlace Control Output
11	VPROT	IN	GNDAB	Vertical Protection Input

Pin No. PSDIP 64-pin	Pin Name	Type	Connection (If not used)	Short Description
12	SAFETY	IN	GNDAB	Safety Input
13	HFLB	IN	HOUT	Horizontal Flyback Input
14	GNDD	SUPPLY	X	Digital Ground
15	VSUPD	SUPPLY	X	Digital Supply Voltage (3.3 V)
16	GNDD	SUPPLY	X	Digital Ground
17	VSUPD	SUPPLY	LV	Digital Supply Voltage (3.3 V)
18	P0	IN/OUT	LV	Port 1, Bit 0
19	P1	IN/OUT	LV	Port 1, Bit 1
20	P2	IN/OUT	GNDD	Port 1, Bit 2
21	P3	IN/OUT	GNDD	Port 1, Bit 3
22	P4	IN/OUT	GNDD	Port 1, Bit 4
23	P5	IN/OUT	GNDD	Port 1, Bit 5
24	P6	IN/OUT	GNDD	Port 1, Bit 6
25	GNDD	SUPPLY	X	Digital Ground
26	RSW2	OUT	GNDAB	Range Switch 2 for Measurement ADC
27	RSW1	OUT	GNDAB	Range Switch 1 for Measurement ADC
28	SENSE	IN	GNDAB	Sense ADC Input
29	GNDM	SUPPLY	X	Ground, MADC Input
30	VERTQ	OUT	LV	Inverted Vertical Sawtooth Output
31	VERT	OUT	LV	Vertical Sawtooth Output
32	E/W	OUT	LV	Vertical Parabola Output
33	XREF	IN	X	Reference Input for RGB DACs
34	SVMOUT	OUT	VSUPAB	Analog Scan Velocity Modulation Output
35	GNDAB	SUPPLY	X	Analog Ground Backend
36	VSUPAB	SUPPLY	X	Analog Supply Voltage (5.0 V) Backend
37	ROUT	OUT	VSUPAB	Analog Red Output
38	GOUT	OUT	VSUPAB	Analog Green Output
39	BOUT	OUT	VSUPAB	Analog Blue Output
40	VRD	IN	X	DAC Reference
41	RIN	IN	GNDAB	Analog Red Input
42	GIN	IN	GNDAB	Analog Green Input

Pin No. PSDIP 64-pin	Pin Name	Type	Connection (If not used)	Short Description
43	BIN	IN	GNDAB	Analog Blue Input
44	FBLIN	IN	GNDAB	Fast Blank Input
45	RIN2	IN	GNDAB	Analog Red Input2
46	GIN2	IN	GNDAB	Analog Green Input2
47	BIN2	IN	GNDAB	Analog Blue Input2
48	FBLIN2	IN	GNDAB	Fast Blank Input2
49	CLK20	OUT	LV	20.25 MHz System Clock Output
50	HOUT	OUT	X	Horizontal Drive Output
51	XTAL 1	IN	X	Analog Crystal Input
52	XTAL 2	OUT	X	Analog Crystal Output
53	CIN 2/CRIN	IN	LV	Analog Chroma 2/Component C <sub>R</sub> Input
54	CBIN	IN	LV	Component C <sub>B</sub> Input
55	GNDAF	SUPPLY	X	Analog Ground Frontend
56	SGND	IN	GNDAF	Signal Ground for Analog Input
57	VRT	IN	X	Reference Voltage Top, Video ADC
58	VSUPAF	SUPPLY	X	Analog Supply Voltage (5.0 V) Frontend
59	VOUT	OUT	LV	Analog Video Output
60	CIN1	IN	VRT	Analog Chroma 1 Input
61	VIN1	IN	VRT	Analog Video 1 Input
62	VIN2	IN	VRT	Analog Video 2 Input
63	VIN3	IN	VRT	Analog Video 3 Input
64	VIN4	IN	VRT	Analog Video 4 Input

### 3.3. Pin Descriptions

Pin 1 – Test Input, **TEST** (Fig. 3–3)

This pin enables factory test modes. For normal operation it must be connected to ground.

Pin 2 – Reset Input, **RESQ** (Fig. 3–4)

A low level on this pin resets the VDP31xxY.

Pin 3 – I<sup>2</sup>C Bus Clock, **SCL** (Fig. 3–4)

This pin connects to the I<sup>2</sup>C bus clock line.

Pin 4 – I<sup>2</sup>C Bus Data, **SDA** (Fig. 3–4)

This pin connects to the I<sup>2</sup>C bus data line.

Pin 5 – Ground (Digital Shield), **GNDD**

Pin 6 – Half Contrast Switch Input, **HCS** (Fig. 3–22)

Via this input pin the output level of the analog RGB output pins can be reduced by 6 dB.

Pin 7 – Front Sync Output, **FSY** (Fig. 3–21)

This pin supplies the front sync information

Pin 8 – Composite Sync Output, **CSY** (Fig. 3–21)

This output supplies a standard composite sync signal that is compatible to the analog RGB output signals.

Pin 9 – Vertical Sync Output, **VS** (Fig. 3–21)

This pin supplies the vertical sync information.

Pin 10 – Interlace Output, **INTLC** (Fig. 3–21)

This pin supplies the interlace information, with programmable polarity.

Pin 11 – Vertical Protection Input, **VPROT** (Fig. 3–14)

The vertical protection circuitry prevents the picture tube from burn-in in the event of a malfunction of the vertical deflection stage. During vertical blanking, a signal level of 2.5 V is sensed. If a negative edge cannot be detected, the RGB output signals are blanked.

Pin 12 – Safety Input, **SAFETY** (Fig. 3–14)

This is a three-level input. Low level means normal function. At the medium level RGB signals are blanked and at high level RGB signals are blanked and horizontal drive is shut off.

Pin 13 – Horizontal Flyback Input, **HFLB** (Fig. 3–14)

Via this pin the horizontal flyback pulse is supplied to the VDP 313xY.

Pin 14 – Ground (Digital Circuitry Front-end), **GNDD**

Pin 15, 17– Supply Voltage (Digital Circuitry), **VSUPD**

Pin 16 – Ground (Digital Circuitry Back-end), **GNDD**

Pin 18–24 – IO Port Expander, **PORT[6:0]** (Fig. 3–21, Fig. 3–22)

These pins provide an I<sup>2</sup>C programmable I/O port, which can be used to read and write slow external signals.

Pin 25 – Ground (Digital Shield), **GNDD**.

Pin 26, 27 – Range Switch for Measurement ADC, **RSW1, RSW2** (Fig. 3–18)

These pins are open drain pull-down outputs. RSW1 is switched off during cutoff and whitedrive measurement. RSW2 is switched off during cutoff measurement only.

Pin 28 – Measurement ADC Input, **SENSE** (Fig. 3–19)

This is the input of the analog digital converter for the picture and tube measurement.

Pin 29 – Ground (Measurement ADC Reference Input), **GNDM**

This is the ground reference for the measurement A/D converter.

Pin 30 – Vertical Sawtooth Output Q, **VERTQ** (Fig. 3–16)

This pin supplies the drive signal for the vertical output stage. The drive signal is generated with 15-bit precision by the Fast Processor in the front-end. The analog voltage is generated by a 4-bit current-DAC with external resistor and uses digital noise shaping.

Pin 31 – Vertical Sawtooth Output, **VERT** (Fig. 3–16)

This pin supplies the inverted signal of pin 30. Together with pin 30 it can be used to drive symmetrical deflection amplifiers.

Pin 32 – East–West Parabola Output, **EW** (Fig. 3–17)

This pin supplies the parabola signal for the East–West correction. The drive signal is generated with 15 bit precision by the Fast Processor in the front-end. The analog voltage is generated by a 4-bit current-DAC with external resistor and uses digital noise shaping.

Pin 33 – DAC Current Reference, **XREF** (Fig. 3–20)

External reference resistor for DAC output currents, typical 10 k $\Omega$  to adjust the output current of the D/A converters. (see recommended operating conditions). This resistor has to be connected to analog ground as closely as possible to the pin without any capacitor.

Pin 34 – Scan Velocity Modulation Output, **SVMOUT** (Fig. 3–12)

This output delivers the analog SVM signal. The D/A converter is a current sink like the RGB D/A converters. At zero signal the output current is 50 % of the maximum output current.

Pin 35 – Ground (Analog Back-end), **GNDA**

Pin 36 – Supply Voltage (Analog Back-end), **VSUPA**

Pin 37, 38, 39 – Analog RGB Outputs, **ROUT**, **GOUT**, **BOUT** (Fig. 3–12)

This are the analog Red/Green/Blue outputs of the backend. The outputs sink a current of max. 8 mA.

Pin 40 – DAC Reference Decoupling, **VRD** (Fig. 3–20)

Via this pin the DAC reference voltage is decoupled by an external capacitance. The DAC output currents depend on this voltage, therefore a pull-down transistor can be used to shut off all beam currents. A decoupling capacitor of 3.3  $\mu$ F/100 nF is required.

Pin 41, 42, 43, 45, 46, 47 – Analog RGB Inputs, **RIN1/2**, **GIN1/2**, **BIN1/2** (Fig. 3–11)

These pins are used to insert an external analog RGB signal, e.g. from a SCART connector which can be switched to the analog RGB outputs with the fast blank signal. The analog backend provides separate brightness and contrast settings for the external analog RGB signals.

Pin 44, 48 – Fast Blank Inputs, **FBLIN1/2** (Fig. 3–15)

These pins are used to switch the RGB outputs to the external analog RGB inputs.

Pin 49 – Main Clock Output, **CLK20** ( Fig. 3–6)

This is the 20.25 MHz main system clock, that is used by all circuits in a high-end VDP system. All external timing is derived from this clock.

Pin 50 – Horizontal Drive Output, **HOUT** (Fig. 3–13)

This open drain output supplies the the drive pulse for the horizontal output stage. The polarity and gating with the flyback pulse are selectable by software.

Pin 51, 52 – Crystal Input and Output, **XTAL1**, **XTAL2** (Fig. 3–5)

These pins are connected to an 20.25 MHz crystal oscillator is digitally tuned by integrated shunt capacitances. The Clk20 signal is derived from this oscillator.

Pin 53, 54, 60– Analog Chroma Inputs, **CIN1**, **CIN2/CRIN**, **CBIN** (Fig. 3–7, Fig. 3–8)

CIN1, CIN2 are the analog chroma inputs for S-VHS. A S-VHS chroma signal is converted using the chroma (Video2) AD converter. A resistive divider is used to BIAS the input signal to middle of converter range. The input signal must be AC coupled. Together with the CBIN pin CIN2 can alternatively be used as chroma component input for the analog YC<sub>R</sub>C<sub>B</sub> interface.

Pin 55 – Ground (Analog Front-end), **GNDAF**

Pin 56 – Ground (Analog Signal Input), **SGND** (Fig. 3–10)

This is the high quality ground reference for the video input signals.

Pin 57 – Reference Voltage Top, **VRT** (Fig. 3–10)

Via this pin, the reference voltage for the A/D converters is decoupled. The pin is connected with 10  $\mu$ F/47 nF to the Signal Ground Pin.

Pin 58 – Supply Voltage (Analog Front-end), **VSUPAF**

Pin 59 – Analog Video Output, **VOUT** (Fig. 3–9)

The analog video signal that is selected for the main (luma, cvbs) adc is output at this pin. An emitter follower is required at this pin.

Pin 61...64 – Analog Video Input 1–4, **VIN1–4** (Fig. 3–7)

These are the analog video inputs. A CVBS or S-VHS luma signal is converted using the luma (Video 1) AD converter. The input signal must be AC-coupled.

### 3.4. Pin Configuration

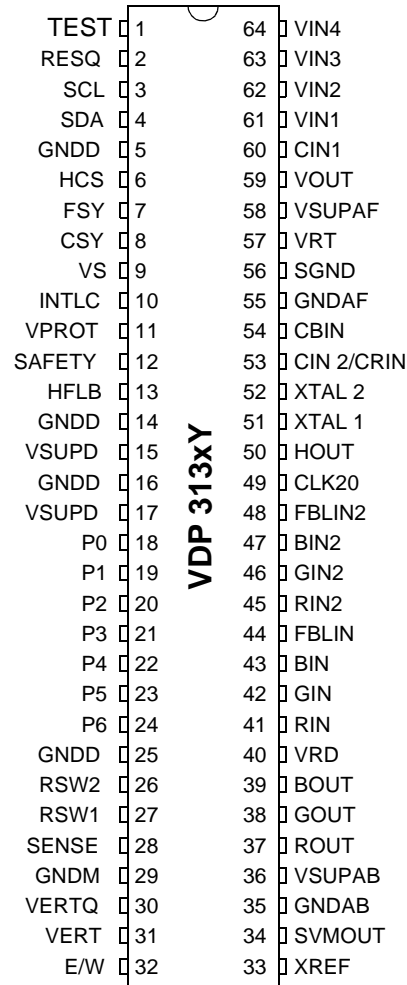

Fig. 3–2: 64-pin PSDIP package



3.5. Pin Circuits

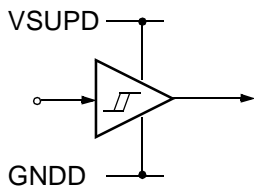

Fig. 3-3: Input pin TEST, RESQ

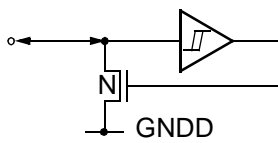

Fig. 3-4: Input/Output pins SDA, SCL

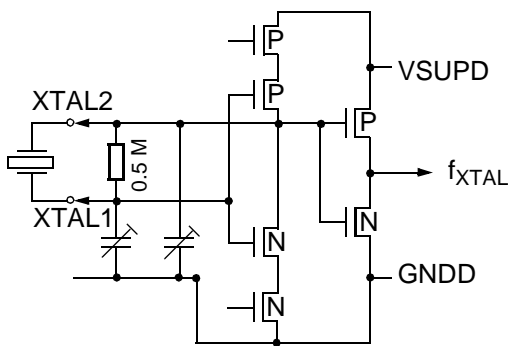

Fig. 3-5: Input/Output pins XTAL1, XTAL2

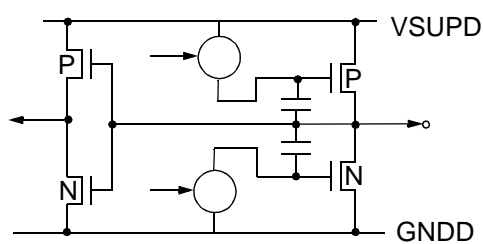

Fig. 3-6: Output pin CLK20

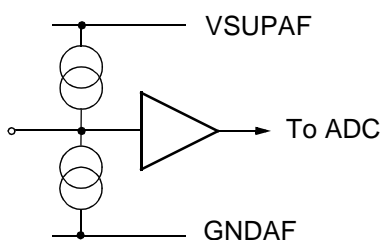

Fig. 3-7: Input pins VIN1-VIN4, CBIN, CRIN

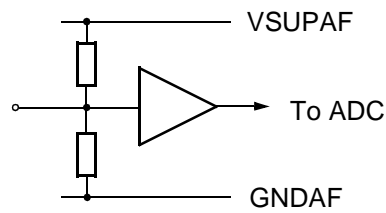

Fig. 3-8: Input pins CIN1, CIN2

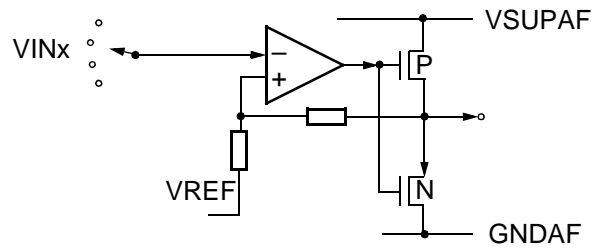

Fig. 3-9: Output pin VOUT

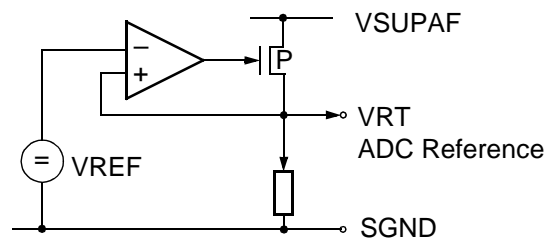

Fig. 3-10: Supply pins VRT, SGND

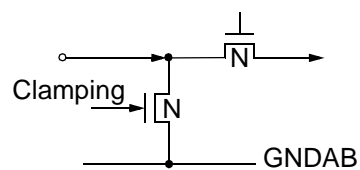

Fig. 3-11: Input pins RIN, GIN, BIN

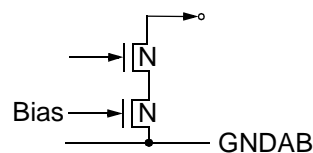

Fig. 3-12: Output pins ROUT, GOUT, BOUT, SVMOUT

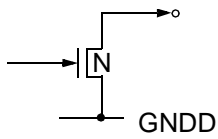

Fig. 3-13: Output pin HOUT

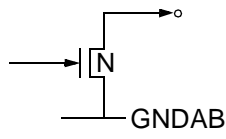

Fig. 3-18: Output pins RSW1, RSW2

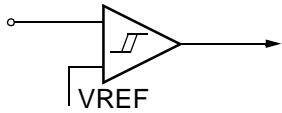

Fig. 3-14: Input pins SAFETY, HFLB, VPROT

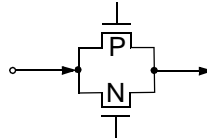

Fig. 3-19: Input pin SENSE

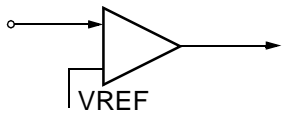

Fig. 3-15: Input pins FBLIN

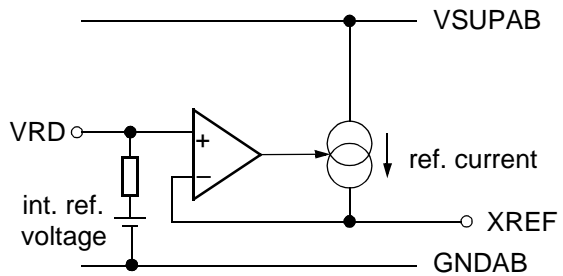

Fig. 3-20: Supply pins XREF, VRD

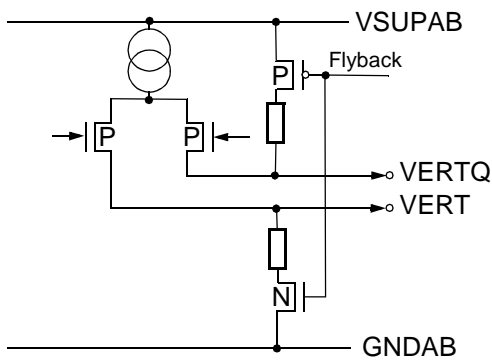

Fig. 3-16: Output pins VERT, VERTQ

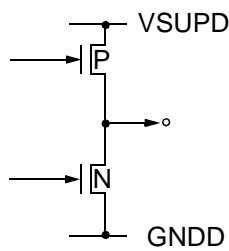

Fig. 3-21: Output pins FSY, VS, CSY, INTLC, PORT[6:0]

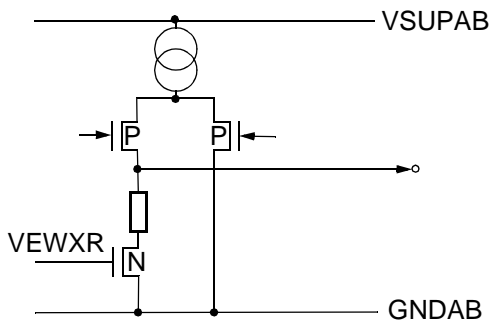

Fig. 3-17: Output pin EW

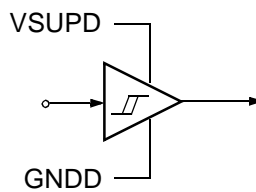

Fig. 3-22: Input pins HCS, PORT[6:0]

### 3.6. Electrical Characteristics

#### 3.6.1. Absolute Maximum Ratings

Symbol	Parameter	Pin Name	Min.	Max.	Unit
$T_J$	Junction Temperature		0	125	°C
$T_S$	Storage Temperature		-40	125	°C
$P_{TOT}$	Total Power Dissipation		-	1400	mW
$V_{SUP_x}$	Supply Voltage	$V_{SUP_x}$	-0.3	6	V
$V_I$	Input Voltage, all Inputs		-0.3	$V_{SUP_x}+0.3^{1)}$	V
$V_O$	Output Voltage, all Outputs		-0.3	$V_{SUP_x}+0.3^{1)}$	V
$V_{IO}$	Input/Output Voltage, all Open Drain Outputs		-0.3	6	V
$V_{ES}$	Electrostatic Handling, HBM <sup>2)</sup>		-2000	+2000	V

<sup>1)</sup> Refer to Pin Circuits (chapter 3.5. on page 57)  
<sup>2)</sup> Human Body Model (HBM): R=1.5 kΩ, C=100 pF

Stresses beyond those listed in the “Absolute Maximum Ratings” may cause permanent damage to the device. This is a stress rating only. Functional operation of the device at these or any other conditions beyond those indicated in the “Recommended Operat-

ing Conditions/Characteristics” of this specification is not implied. Exposure to absolute maximum ratings conditions for extended periods may affect device reliability.

#### 3.6.2. Recommended Operating Conditions

Symbol	Parameter	Pin Name	Min.	Typ.	Max.	Unit
$T_A$	Ambient Operating Temperature		0	-	65	°C
$f_{XTAL}$	Clock Frequency	XTAL1/2	-	20.25	-	MHz
$V_{SUP_A}$	Analog Supply Voltage	$V_{SUP_{AF}}$ $V_{SUP_{AB}}$	4.75	5.0	5.25	V
$V_{SUP_D}$	Digital Supply Voltage	$V_{SUP_D}$	3.15	3.3	3.45	V

## 3.6.2.1. Analog Input and Output Recommendations

Symbol	Parameter	Pin Name	Min.	Typ.	Max.	Unit
<b>Video</b>						
$V_{VIN}$	Video Input Level	VIN1-4, CIN1-2	0.5	1.0	3.5	$V_{PP}$
$V_{CIN}$	Chroma Input Level	CRIN, CBIN	–	700	–	mV
$C_{VIN}$	Input Coupling Capacitor Video Inputs	VIN1-4	–	680	–	nF
$C_{CIN}$	Input Coupling Capacitor Chroma Inputs	CIN1-2	–	1	–	nF
$C_{CCIN}$	Input Coupling Capacitor Component Inputs	CRIN, CBIN	–	220	–	nF
<b>RGB</b>						
$R_{xref}$	RGB-DAC Current defining Resistor	XREF	9.5	10	10.5	k $\Omega$
$C_{RGBIN}$	RGB Input Coupling Capacitor	RIN GIN BIN	–	15	–	nF
<b>Deflection</b>						
$R_{load}$	Deflection Load Resistance	EW, VERT, VERTQ	–	6.8	–	k $\Omega$
$C_{load}$	Deflection Load Capacitance		–	68	–	nF

## 3.6.3. Recommended Crystal Characteristics

Symbol	Parameter	Min.	Typ.	Max.	Unit
T <sub>A</sub>	Operating Ambient Temperature	0	–	65	°C
f <sub>P</sub>	Parallel Resonance Frequency with Load Capacitance <b>C<sub>L</sub> = 13 pF</b>	–	20.250000	–	MHz
Δf <sub>P</sub> /f <sub>P</sub>	Accuracy of Adjustment	–	–	±20	ppm
Δf <sub>P</sub> /f <sub>P</sub>	Frequency Temperature Drift	–	–	±30	ppm
R <sub>R</sub>	Series Resistance	–	–	25	Ω
C <sub>0</sub>	Shunt Capacitance	3	–	7	pF
C <sub>1</sub>	Motional Capacitance	20	–	30	fF
<b>Load Capacitance Recommendation</b>					
C <sub>Lext</sub>	External Load Capacitance <sup>1)</sup> from pins to Ground (pin names: Xtal1 Xtal2)	–	3.3	–	pF
<b>DCO Characteristics <sup>2,3)</sup></b>					
C <sub>ICLoadmin</sub>	Effective Load Capacitance @ min. DCO–Position, Code 0, package: 64PSDIP	3	4.3	5.5	pF
C <sub>ICLoadrng</sub>	Effective Load Capacitance Range, DCO Codes from 0..255	11	12.7	15	pF
<p><sup>1)</sup> Remarks on defining the External Load Capacitance:  External capacitors at each crystal pin to ground are required. They are necessary to tune the effective load capacitance of the PCBs to the required load capacitance C<sub>L</sub> of the crystal. The higher the capacitors, the lower the clock frequency results. The nominal free running frequency should match f<sub>0</sub> MHz. Due to different layouts of customer PCBs the matching capacitor size should be determined in the application. The suggested value is a figure based on experience with various PCB layouts.  Tuning condition: Code DVCO Register = –720</p> <p><sup>2)</sup> Remarks on Pulling Range of DCO:  The pulling range of the DCO is a function of the used crystal and effective load capacitance of the IC (C<sub>ICLoad</sub> + C<sub>LoadBoard</sub>). The resulting frequency f<sub>L</sub> with an effective load capacitance of C<sub>Leff</sub> = C<sub>ICLoad</sub> + C<sub>LoadBoard</sub> is:</p> $f_L = f_P \times \frac{1 + 0.5 \times [ C_1 / (C_0 + C_{Leff}) ]}{1 + 0.5 \times [ C_1 / (C_0 + C_L) ]}$ <p><sup>3)</sup> Remarks on DCO codes  The DCO hardware register has 8 bits, the fp control register uses a range of –2048...2047</p>					

### 3.6.4. Characteristics

If not otherwise designated under test conditions, all characteristics are specified for recommended operating conditions (see Section 3.6.2. on page 59).

#### 3.6.4.1. General Characteristics

Symbol	Parameter	Pin Name	Min.	Typ.	Max.	Unit	Test Conditions
$P_{TOT}$	Total Power Dissipation		–	900	1400	mW	
$I_{VSUPD}$	Current Consumption Digital Circuitry	$VSUP_D$	–	118	–	mA	
$I_{VSUPAF}$	Current Consumption Analog Frontend	$VSUP_{AF}$	–	35	–	mA	
$I_{VSUPAB}$	Current Consumption Analog Backend	$VSUP_{AB}$	–	58	–	mA	depends on contrast and brightness settings
$I_L$	Input and Output Leakage Current	All I/O Pins	–1	–	1	$\mu$ A	

#### 3.6.4.2. I<sup>2</sup>C Bus Interface

Symbol	Parameter	Pin Name	Min.	Typ.	Max.	Unit	Test Conditions
$V_{IL}$	Input Low Voltage	SDA, SCL	–	–	0.3	VSUPD	
$V_{IH}$	Input High Voltage		0.6	–	–	VSUPD	
$V_{OL}$	Output Low Voltage		–	–	0.4 0.6	V V	$I_I = 3$ mA $I_I = 6$ mA
$V_{IH}$	Input Capacitance		–	–	5	pF	
$t_F$	Signal Fall Time		–	–	300	ns	$C_L = 400$ pF
$t_R$	Signal Rise Time		–	–	300	ns	$C_L = 400$ pF
$f_{SCL}$	Clock Frequency	SCL	0	–	400	kHz	
$t_{LOW}$	Low Period of SCL		1.3	–	–	$\mu$ s	
$t_{HIGH}$	High Period of SCL		0.6	–	–	$\mu$ s	
$t_{SU\ Data}$	Data Set Up Time to SCL high	SDA	100	–	–	ns	
$t_{HD\ Data}$	DATA Hold Time to SCL low		0	–	0.9	$\mu$ s	

#### 3.6.4.3. Reset Input

Symbol	Parameter	Pin Name	Min.	Typ.	Max.	Unit	Test Conditions
$V_{IL}$	Input Low Voltage	RESQ	–	–	0.8	V	
$V_{IH}$	Input High Voltage	RESQ	2	–	–	V	

3.6.4.4. Power-up Sequence

Symbol	Parameter	Pin Name	Min.	Typ.	Max.	Unit	Test Conditions
$t_{Vdel}$	Ramp Up Difference of Supplies		0	–	$\pm 1$	s	
$t_{Vrmp}$	Transition Time of Supplies		–	–	50	ms	

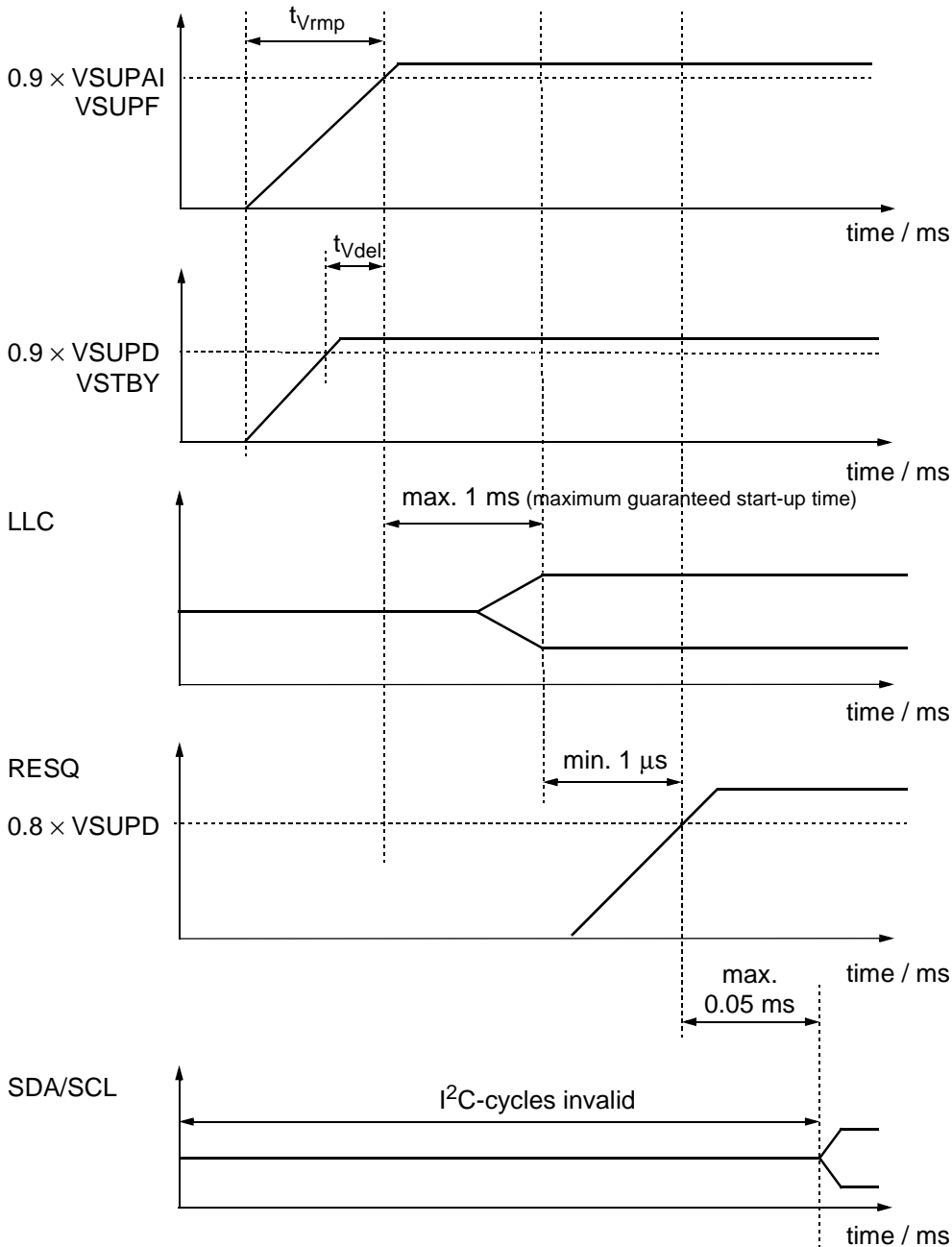

Fig. 3–23: Power-Up sequence

## 3.6.4.5. Test Input

Symbol	Parameter	Pin Name	Min.	Typ.	Max.	Unit	Test Conditions
V <sub>IL</sub>	Input Low Voltage	TEST	–	–	0.8	V	
V <sub>IH</sub>	Input High Voltage		2.0	–	–	V	
I <sub>pd</sub>	Input Pull-Down Current		25	80	170	μA	V <sub>i</sub> = V <sub>SUPD</sub>

## 3.6.4.6. Analog Video Front-End and A/D Converters

Symbol	Parameter	Pin Name	Min.	Typ.	Max.	Unit	Test Conditions
V <sub>VRT</sub>	Reference Voltage Top	VRT	2.5	2.6	2.8	V	10 μF/10 nF, 1 GΩ Probe
V <sub>VRTN</sub>	Reference Voltage Top Noise		–	–	100	mV <sub>PP</sub>	

**Luma – Path**

R <sub>VIN</sub>	Input Resistance	VIN1-4	1	–	–	MΩ	Code Clamp–DAC=0
C <sub>VIN</sub>	Input Capacitance		–	5	–	pF	
V <sub>VIN</sub>	Full Scale Input Voltage		1.8	2.0	2.2	V <sub>PP</sub>	min. AGC Gain
V <sub>VIN</sub>	Full Scale Input Voltage		0.5	0.6	0.7	V <sub>PP</sub>	max. AGC Gain
AGC	AGC step width		–	0.166	–	dB	6-Bit Resolution= 64 Steps f <sub>sig</sub> = 1 MHz, – 2 dBr of max. AGC–Gain
DNL <sub>AGC</sub>	AGC Differential Non-Linearity		–	–	±0.5	LSB	
V <sub>VINCL</sub>	Input Clamping Level, CVBS		–	1.0	–	V	Binary Level = 64 LSB min. AGC Gain
Q <sub>CL</sub>	Clamping DAC Resolution		–16	–	15	steps	5 Bit – I–DAC, bipolar V <sub>VIN</sub> =1.5 V
I <sub>CL–LSB</sub>	Input Clamping Current per step		0.7	1.0	1.3	mA	
DNL <sub>ICL</sub>	Clamping DAC Differential Non-Linearity		–	–	±0.5	LSB	

**Chroma – Path (composite)**

R <sub>CIN</sub>	Input Resistance SVHS Chroma	CIN1 CIN2	1.4	2.0	2.6	kΩ	
V <sub>CIN</sub>	Full Scale Input Voltage, Chroma		1.08	1.2	1.32	V <sub>PP</sub>	
V <sub>CINDC</sub>	Input Bias Level, SVHS Chroma		–	1.5	–	V	
	Binary Code for Open Chroma Input		–	128	–	–	

**Chroma – Path (component)**

R <sub>VIN</sub>	Input Resistance	CBIN, CRIN	1			MΩ	Code Clamp–DAC = 0
C <sub>VIN</sub>	Input Capacitance				4.5	pF	
V <sub>VIN</sub>	Full Scale Input Voltage		0.76	0.84	0.92	V <sub>PP</sub>	minimal range
V <sub>VIN</sub>	Full Scale Input Voltage		1.08	1.2	1.32	V <sub>PP</sub>	extended range



Symbol	Parameter	Pin Name	Min.	Typ.	Max.	Unit	Test Conditions
V <sub>INCL</sub>	Input Clamping Level C <sub>R</sub> , C <sub>B</sub>			1.5		V	Binary Level = 128 LSB
Q <sub>CL</sub>	Clamping DAC Resolution		-32		31	steps	6 Bit – I-DAC, bipolar V <sub>VIN</sub> = 1.5 V
I <sub>CL-LSB</sub>	Input Clamping Current per step		0.59	0.85	1.11	μA	
DNL <sub>ICL</sub>	Clamping DAC Differential Non-Linearity				±0.5	LSB	
<b>Dynamic Characteristics for all Video-Paths (Luma + Chroma)</b>							
BW	Bandwidth	VIN1-4 CIN1-2 CBIN	8	10	–	MHz	-2 dBr input signal level
XTALK	Crosstalk, any Two Video Inputs		–	-56	–	dB	1 MHz, -2 dBr signal level
THD	Total Harmonic Distortion		–	50	–	dB	1 MHz, 5 harmonics, -2 dBr signal level
SINAD	Signal to Noise and Distortion Ratio		–	45	–	dB	1 MHz, all outputs, -2 dBr signal level
INL	Integral Non-Linearity		–	–	±1	LSB	Code Density, DC-ramp
DNL	Differential Non-Linearity		–	–	±0.8	LSB	
DG	Differential Gain		–	–	±3	%	-12 dBr, 4.4 MHz signal on DC-ramp
DP	Differential Phase		–	–	1.5	deg	

**3.6.4.7. Horizontal Flyback Input**

Symbol	Parameter	Pin Name	Min.	Typ.	Max.	Unit	Test Conditions
$V_{IL}$	Input Low Voltage	HFLB	–	–	1.8	V	
$V_{IH}$	Input High Voltage		2.6	–	–	V	
$V_{IHST}$	Input Hysteresis		0.1	–	–	V	
$PSRR_{HF}$	Power Supply Rejection Ratio of Trigger Level		0	–	–	dB	$f = 20 \text{ MHz}$
$PSRR_{MF}$	Power Supply Rejection Ratio of Trigger Level		–20	–	–	dB	$f < 15 \text{ kHz}$
$PSRR_{LF}$	Power Supply Rejection Ratio of Trigger Level		–40	–	–	dB	$f < 100 \text{ Hz}$

**3.6.4.8. Horizontal Drive Output**

Symbol	Parameter	Pin Name	Min.	Typ.	Max.	Unit	Test Conditions
$V_{OL}$	Output Low Voltage	HOUT	–	–	0.4	V	$I_{OL} = 10 \text{ mA}$
$V_{OH}$	Output High Voltage (Open Drain Stage)		–	–	5	V	external pull-up resistor
$t_{OF}$	Output Fall Time		–	8	20	ns	$C_{LOAD} = 30 \text{ pF}$
$I_{OL}$	Output Low Current		–	–	10	mA	

**3.6.4.9. Vertical Protection Input**

Symbol	Parameter	Pin Name	Min.	Typ.	Max.	Unit	Test Conditions
$V_{IL}$	Input Low Voltage	VPROT	–	–	1.8	V	
$V_{IH}$	Input High Voltage		2.6	–	–	V	
$V_{IHST}$	Input Hysteresis		0.1	–	–	V	

**3.6.4.10. Vertical Safety Input**

Symbol	Parameter	Pin Name	Min.	Typ.	Max.	Unit	Test Conditions
$V_{ILA}$	Input Low Voltage A	SAFETY	–	–	1.8	V	
$V_{IHA}$	Input High Voltage A		2.6	–	–	V	
$V_{ILB}$	Input Low Voltage B		–	–	3.0	V	
$V_{IHB}$	Input High Voltage B		3.8	–	–	V	
$V_{IHST}$	Input Hysteresis A and B		0.1	–	–	V	
$t_{PID}$	Internal Delay		–	–	100	ns	

**3.6.4.11. Vertical and East/West D/A Converter Output**

Symbol	Parameter	Pin Name	Min.	Typ.	Max.	Unit	Test Conditions
V <sub>OMIN</sub>	Minimum Output Voltage	EW VERT VERTQ	–	0	–	V	R <sub>load</sub> = 6.8 kΩ R <sub>xref</sub> = 10 kΩ
V <sub>OMAX</sub>	Maximum Output Voltage		2.82	3	3.2	V	R <sub>load</sub> = 6.8 kΩ R <sub>xref</sub> = 10 kΩ
I <sub>DACN</sub>	Full scale DAC Output Current		415	440	465	μA	R <sub>xref</sub> = 10 kΩ
PSRR	Power Supply Rejection Ratio		–	20	–	dB	

**3.6.4.12. Combined Sync, Vertical Sync, Interlace and Front Sync Output**

Symbol	Parameter	Pin Name	Min.	Typ.	Max.	Unit	Test Conditions
V <sub>OL</sub>	Output Low Voltage	CSY VS INTLC FSY	–	0.2	0.4	V	I <sub>OL</sub> = 1.6 mA
V <sub>OH</sub>	Output High Voltage		V <sub>SUPD</sub> – 0.4	–	V <sub>SUPD</sub>	V	–I <sub>OL</sub> = 1.6 mA

**3.6.4.13. CLK20 Output**

Symbol	Parameter	Pin Name	Min.	Typ.	Max.	Unit	Test Conditions
V <sub>OL</sub>	Output Low Voltage	CLK20	–	0.2	0.4	V	I <sub>OL</sub> = TBD; strenght = TBD
V <sub>OH</sub>	Output High Voltage		V <sub>SUPD</sub> – 0.4	–	V <sub>SUPD</sub>	V	I <sub>OL</sub> = TBD; strenght = TBD

**3.6.4.14. Sense A/D Converter Input**

Symbol	Parameter	Pin Name	Min.	Typ.	Max.	Unit	Test Conditions
V <sub>I</sub>	Input Voltage Range	SENSE	0	–	V <sub>SUPAB</sub>	V	
V <sub>I255</sub>	Input Voltage for code 255		1.4	1.54	1.7	V	Read cutoff blue register
C <sub>0</sub>	Digital Output for zero Input		–	–	16	LSB	Offset check, read cutoff blue register
R <sub>I</sub>	Input Impedance		1	–	–	MΩ	

**3.6.4.15. Range Switch Output**

Symbol	Parameter	Pin Name	Min.	Typ.	Max.	Unit	Test Conditions
R <sub>ON</sub>	Output On Resistance	RSW1 RSW2	–	–	50	Ω	I <sub>OL</sub> = 10 mA
I <sub>Max</sub>	Maximum Current		–	–	15	mA	
I <sub>LEAK</sub>	Leakage Current		–	–	600	nA	RSW High Impedance

**3.6.4.16. Scan Velocity Modulation Output**

Symbol	Parameter	Pin Name	Min.	Typ.	Max.	Unit	Test Conditions
	Resolution	SVMOUT	–	8	–	bit	
$I_{OUT}$	Full Scale Output Current		1.55	1.875	2.25	mA	
$I_{OUT}$	Differential Nonlinearity		–	–	0.5	LSB	
$I_{OUT}$	Integral Nonlinearity		–	–	1	LSB	
$I_{OUT}$	Glitch Pulse Charge		–	0.5	–	pAs	Ramp, output line is terminated on both ends with 50 $\Omega$
$I_{OUT}$	Rise and Fall Time		–	3	–	ns	10 % to 90 %, 90 % to 10 %

**3.6.4.17. D/A Converter Reference**

Symbol	Parameter	Pin Name	Min.	Typ.	Max.	Unit	Test Conditions
$V_{DACREF}$	DAC-Ref. Voltage	VRD	2.38	2.50	2.63	V	
$V_{DACR}$	DAC-Ref. Output resistance		18	25	32	k $\Omega$	
$V_{XREF}$	DAC-Ref. Voltage Bias Current Generation	XREF	2.38	2.5	2.63	V	$R_{xref} = 10 \text{ k}\Omega$

## 3.6.4.18. Analog RGB and FB Inputs

Symbol	Parameter	Pin Name	Min.	Typ.	Max.	Unit	Test Conditions
<b>RGB Input Characteristics</b>							
$V_{RGBIN}$	External RGB Inputs Voltage Range	RIN1/2 GIN1/2 BIN1/2	-0.3	-	1.1	V	
$V_{RGBIN}$	nominal RGB Input Voltage peak-to-peak		0.5	0.7	1.0	V <sub>PP</sub>	SCART Spec: 0.7 V ±3 dB
$V_{RGBIN}$	RGB Inputs Voltage for Maximum Output Current		-	0.44	-	V	Contrast setting: 511
			-	0.7	-	V	Contrast setting: 323
			-	1.1	-	V	Contrast setting: 204
$t_{CLP}$	Clamp Pulse Width		1.6	-	-	μs	
$C_{IN}$	Input Capacitance		-	-	13	pF	
$I_{IL}$	Input Leakage Current		-0.5	-	0.5	μA	Clamping OFF, $V_{IN} = -0.3...3$ V
$V_{CLIP}$	RGB Input Voltage for Clipping Current		-	2	-	V	
$V_{CLAMP}$	Clamp Level at Input		40	60	80	mV	Clamping ON
$V_{INOFF}$	Offset Level at Input		-10	-	10	mV	Extrapolated from $V_{IN} = 100$ and 200 mV
$V_{INOFF}$	Offset Level Match at Input		-10	-	10	mV	Extrapolated from $V_{IN} = 100$ and 200 mV
$R_{CLAMP}$	Clamping-ON-Resistance	-	140	-	Ω		
<b>Fast Blank Input Characteristics</b>							
$V_{FBLOFF}$	FBLIN Low Level	FBLIN1/2	-	-	0.5	V	
$V_{FBLON}$	FBLIN High Level		0.9	-	-	V	
$V_{FBLTRIG}$	Fast Blanking Trigger Level typical		-	0.7	-	V	
$t_{PID}$	Delay Fast Blanking to RGB <sub>OUT</sub> from midst of FBLIN-transition to 90 % of RGB <sub>OUT</sub> transition		-	8	15	ns	Internal RGB = 3.75 mA Full Scale Int. Brightness = 0 External Brightness = 1.5 mA (Full Scale) RGBin = 0 $V_{FBLOFF} = 0.4$ V $V_{FBLON} = 1.0$ V Rise and fall time = 2 ns
	Difference of Internal Delay to External RGBin Delay		-5	-	+5	ns	
	Switch-Over-Glitch	-	0.5	-	pAs	Switch from 3.75 mA (int) to 1.5 mA (ext)	

## 3.6.4.19. Half Contrast Switch Input

Symbol	Parameter	Pin Name	Min.	Typ.	Max.	Unit	Test Conditions
$V_{IL}$	Input Low Voltage	HCS	–	–	0.8	V	
$V_{IH}$	Input High Voltage		1.5	–	–	V	
$t_{HCS}$	Delay HCS to $RGB_{OUT}$ from 50 % of HCS-transition to 90 % of $RGB_{OUT}$ -transition			80	120	ns	Internal GRB = 3.75 mA $V_{HCSL} = 0.4$ V $V_{HCSH} = 1.0$ V Rise and fall time = 2 ns

## 3.6.4.20. Analog RGB Outputs, D/A Converters

Symbol	Parameter	Pin Name	Min.	Typ.	Max.	Unit	Test Conditions
<b>Internal RGB Signal D/A Converter Characteristics</b>							
	Resolution	ROUT GOUT BOUT	–	10	–	bit	
$I_{OUT}$	Full Scale Output Current		3.6	3.75	3.9	mA	$R_{ref} = 10$ k $\Omega$
$I_{OUT}$	Differential Nonlinearity		–	–	0.5	LSB	
$I_{OUT}$	Integral Nonlinearity		–	–	1	LSB	
$I_{OUT}$	Glitch Pulse Charge		–	0.5	–	pAs	Ramp signal, 25 $\Omega$ output termination
$I_{OUT}$	Rise and Fall Time		–	3	–	ns	10 % to 90 %, 90 % to 10 %
$I_{OUT}$	Intermodulation		–	–	–50	dB	2/2.5 MHz full scale
$I_{OUT}$	Signal to Noise		+50	–	–	dB	Signal: 1 MHz full scale Bandwidth: 10 MHz
$I_{OUT}$	Matching R-G, R-B, G-B		–2	–	2	%	
	R/B/G Crosstalk one channel talks two channels talk		–	–	–46	dB	Passive channel: $I_{OUT} = 1.88$ mA Crosstalk-Signal: 1.25 MHz, 3.75 mA <sub>PP</sub>
	RGB Input Crosstalk from external RGB one channel talks two channels talk three channels talk	–	–	–50	dB		
		–	–	–50	dB		
<b>Internal RGB Brightness D/A Converter Characteristics</b>							
	Resolution	ROUT GOUT BOUT	–	9	–	bit	
$I_{BR}$	Full Scale Output Current relative		39.2	40	40.8	%	Ref to max. digital RGB
$I_{BR}$	Full Scale Output Current absolute		–	1.5	–	mA	
$I_{BR}$	Differential Nonlinearity		–	–	1	LSB	
$I_{BR}$	Integral Nonlinearity		–	–	2	LSB	
$I_{BR}$	Match R-G, R-B, G-B		–2	–	2	%	
$I_{BR}$	Match to digital RGB R-R, G-G, B-B		–2	–	2	%	

Symbol	Parameter	Pin Name	Min.	Typ.	Max.	Unit	Test Conditions
<b>External RGB Voltage/Current Converter Characteristics</b>							
	Resolution	ROUT GOUT BOUT	–	9	–	bit	
I <sub>EXOUT</sub>	Full Scale Output Current relative		96	100	104	%	Ref. to max. Digital RGB V <sub>IN</sub> = 0.7 V <sub>PP</sub> contrast = 323
	Full Scale Output Current absolute		–	3.75	–	mA	Same as Digital RGB
CR	Contrast Adjust Range		–	16:511	–		
	Gain Match R-G, R-B, G-B		–2	–	2	%	Measured at RGB Outputs V <sub>IN</sub> = 0.7 V, contrast = 323
	Gain Match to RGB-DACs R-R, G-G, B-B		–3	–	3	%	Measured at RGB Outputs V <sub>IN</sub> = 0.7 V, contrast = 323
	R/B/G Input Crosstalk one channel talks two channels talk		–	–	–46	dB	Passive channel: V <sub>IN</sub> = 0.7 V, contrast = 323 Crosstalk signal: 1.25 MHz, 3.75 mA <sub>PP</sub>
	RGB Input Crosstalk from Internal RGB one channel talks two channels talk tree channels talk		–	–	–50	dB	
	RGB Input Noise and Distortion		–	–	–50	dB	V <sub>IN</sub> =0.7 V <sub>PP</sub> at 1 MHz contrast = 323 Bandwidth: 10 MHz
	RGB Input Bandwidth –3dB			15	–	MHz	V <sub>IN</sub> = 0.7 V <sub>PP</sub> contrast =323
	RGB Input THD		– –	–50 –40	– –	dB dB	Input signal 1 MHz Input signal 6 MHz V <sub>IN</sub> = 0.7 V <sub>PP</sub> contrast =323
	Differential Nonlinearity of Contrast Adjust		–	–	1	LSB	V <sub>IN</sub> = 0.44 V
	Integral Nonlinearity of Contrast Adjust		–	–	2	LSB	
V <sub>RGBO</sub>	R,G,B Output Voltage		–1.0	–	0.3	V	Referred to V <sub>SUPO</sub>
	R,G,B Output Load Resistance		–	–	100	Ω	Ref. to V <sub>SUPO</sub>
V <sub>OUTC</sub>	RGB Output Compliance		–1.5	–1.3	–1.2	V	Ref. to V <sub>SUPO</sub> Sum of max. Current of RGB- DACs and max. Current of Int. Brightness DACs is 2 % degraded

Symbol	Parameter	Pin Name	Min.	Typ.	Max.	Unit	Test Conditions
<b>External RGB Brightness D/A Converter Characteristics</b>							
	Resolution	ROUT GOUT BOUT	–	9	–	bit	
I <sub>EXBR</sub>	Full Scale Output Current relative		39.2	40	40.8	%	Ref to max. digital RGB
	Full Scale Output Current absolute		–	1.5	–	mA	
	Differential Nonlinearity		–	–	1	LSB	
	Integral Nonlinearity		–	–	2	LSB	
	Matching R-G, R-B, G-B		–2	–	2	%	
	Matching to digital RGB R-R, G-G, B-B		–2	–	2	%	
<b>RGB Output Cutoff D/A Converter Characteristics</b>							
	Resolution	ROUT GOUT BOUT	–	9	–	bit	
I <sub>CUT</sub>	Full Scale Output Current relative		58.8	60	61.2	%	Ref to max. digital RGB
	Full Scale Output Current absolute		–	2.25	–	mA	
	Differential nonlinearity		–	–	1	LSB	
	Integral nonlinearity		–	–	2	LSB	
	Matching to digital RGB R-R, G-G, B-B		–2	–	2	%	
<b>RGB Output Ultrablack D/A Converter Characteristics</b>							
	Resolution	ROUT GOUT BOUT	–	1	–	bit	
I <sub>UB</sub>	Full Scale Output Current relative		19.6	20	20.4	%	Ref to max. digital RGB
	Full Scale Output Current absolute		–	0.75	–	mA	
	Match to digital RGB R-R, G-G, B-B	–2	–	2	%		



## 3.6.4.21. IO Ports

Symbol	Parameter	Pin Name	Min.	Typ.	Max.	Unit	Test Conditions
$V_{ol}$	Output Low Voltage	PORT[6:0]	–	–	0.4	V	$I_o = 3 \text{ mA}$
$V_{oh}$	Output High Voltage		$V_{SUPD} - 0.4$	–	–	V	$I_o = -3 \text{ mA}$
$V_{ol}$	Output Low Voltage				1	V	$I_o = 10 \text{ mA}$
$V_{oh}$	Output High Voltage		$V_{SUPD} - 1 \text{ V}$				$I_o = -10 \text{ mA}$
$V_{IL}$	Input Low Voltage		–	–	0.8	V	
$V_{IH}$	Input High Voltage		2.0	–	–	V	
$I_i$	Input Leakage Current		–0.1	–	0.1	$\mu\text{A}$	$0 < V_i < V_{SUPP}$

4. Application Circuit

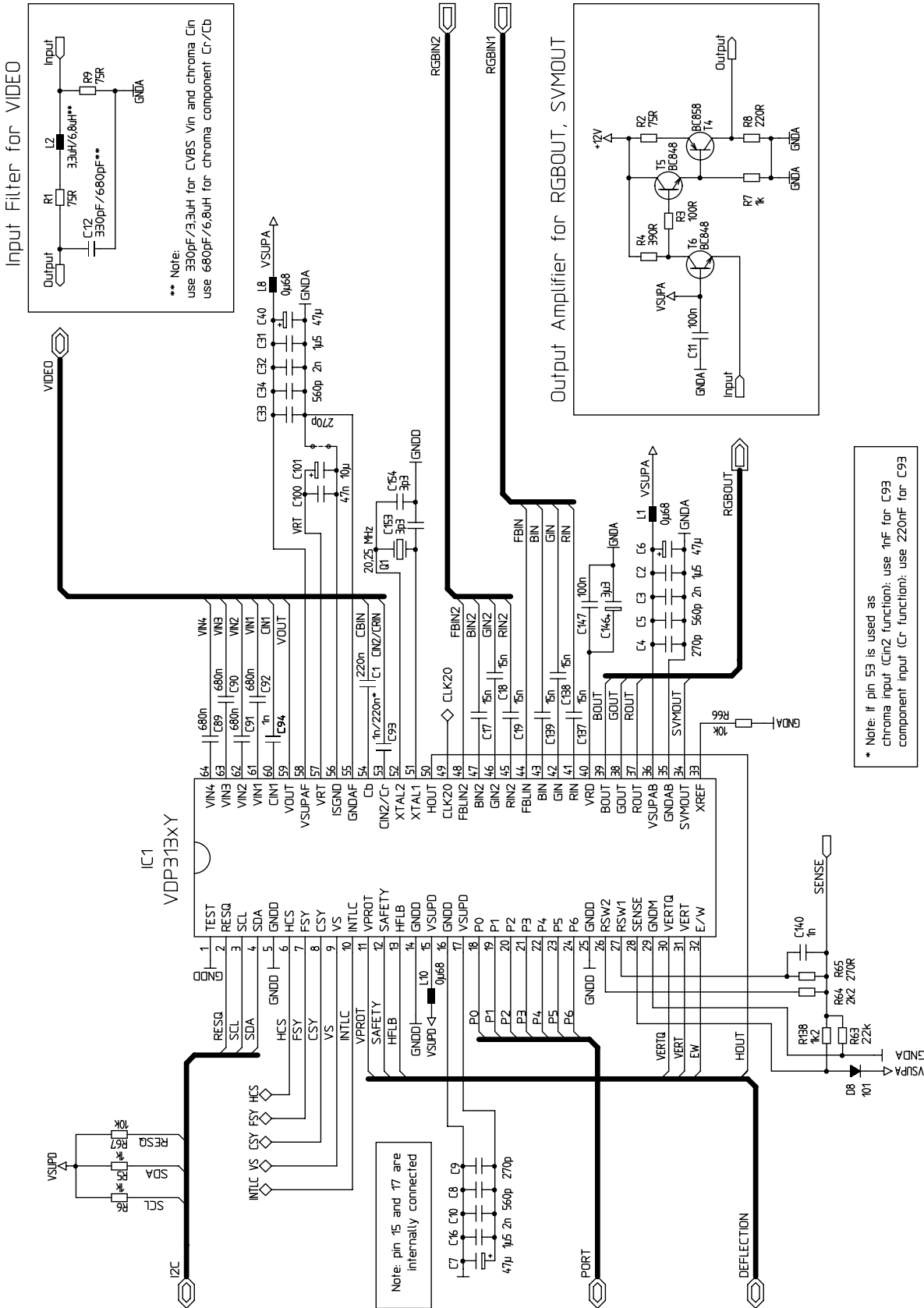

Fig. 4-1: VDP 313xY Application Circuit



## 5. Data Sheet History

1. Advance Information: "VDP 313xY Video Processor Family", August 15, 2000, 6251-519-1AI. First release of the advance information.

Micronas GmbH  
Hans-Bunte-Strasse 19  
D-79108 Freiburg (Germany)  
P.O. Box 840  
D-79008 Freiburg (Germany)  
Tel. +49-761-517-0  
Fax +49-761-517-2174  
E-mail: [docservice@micronas.com](mailto:docservice@micronas.com)  
Internet: [www.micronas.com](http://www.micronas.com)

Printed in Germany  
Order No. 6251-519-1AI

All information and data contained in this data sheet are without any commitment, are not to be considered as an offer for conclusion of a contract, nor shall they be construed as to create any liability. Any new issue of this data sheet invalidates previous issues. Product availability and delivery are exclusively subject to our respective order confirmation form; the same applies to orders based on development samples delivered. By this publication, Micronas GmbH does not assume responsibility for patent infringements or other rights of third parties which may result from its use.

Further, Micronas GmbH reserves the right to revise this publication and to make changes to its content, at any time, without obligation to notify any person or entity of such revisions or changes.

No part of this publication may be reproduced, photocopied, stored on a retrieval system, or transmitted without the express written consent of Micronas GmbH.