

TENTATIVE TOSHIBA BIPOLAR LINEAR INTEGRATED CIRCUIT SILICON MONOLITHIC

TA1274F

PIF / SIF SYNCHRONOUS DEMODULATOR IC

FEATURES

- Compatible pin assignment to TA1267AF

PIF CIRCUIT

- True synchronous PIF demodulator
- 3-stages gain controlled PIF amplifier
- High speed response PIF AGC detector
- Buzz reducer
- Equalizer for video output
- AFT detector without extra reference circuit

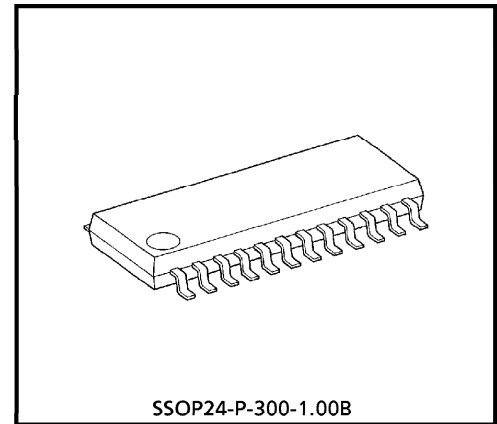

SSOP24-P-300-1.00B

Weight : 0.27 g (Typ.)

SIF CIRCUIT

- Wide range gain controlled SIF amplifier (control range : 70 dB Typ.)
- Alignment-free PLL-FM demodulator

980910EBA1

- TOSHIBA is continually working to improve the quality and the reliability of its products. Nevertheless, semiconductor devices in general can malfunction or fail due to their inherent electrical sensitivity and vulnerability to physical stress. It is the responsibility of the buyer, when utilizing TOSHIBA products, to observe standards of safety, and to avoid situations in which a malfunction or failure of a TOSHIBA product could cause loss of human life, bodily injury or damage to property. In developing your designs, please ensure that TOSHIBA products are used within specified operating ranges as set forth in the most recent products specifications. Also, please keep in mind the precautions and conditions set forth in the TOSHIBA Semiconductor Reliability Handbook.
- The products described in this document are subject to the foreign exchange and foreign trade laws.
- The information contained herein is presented only as a guide for the applications of our products. No responsibility is assumed by TOSHIBA CORPORATION for any infringements of intellectual property or other rights of the third parties which may result from its use. No license is granted by implication or otherwise under any intellectual property or other rights of TOSHIBA CORPORATION or others.
- The information contained herein is subject to change without notice.

BLOCK DIAGRAM

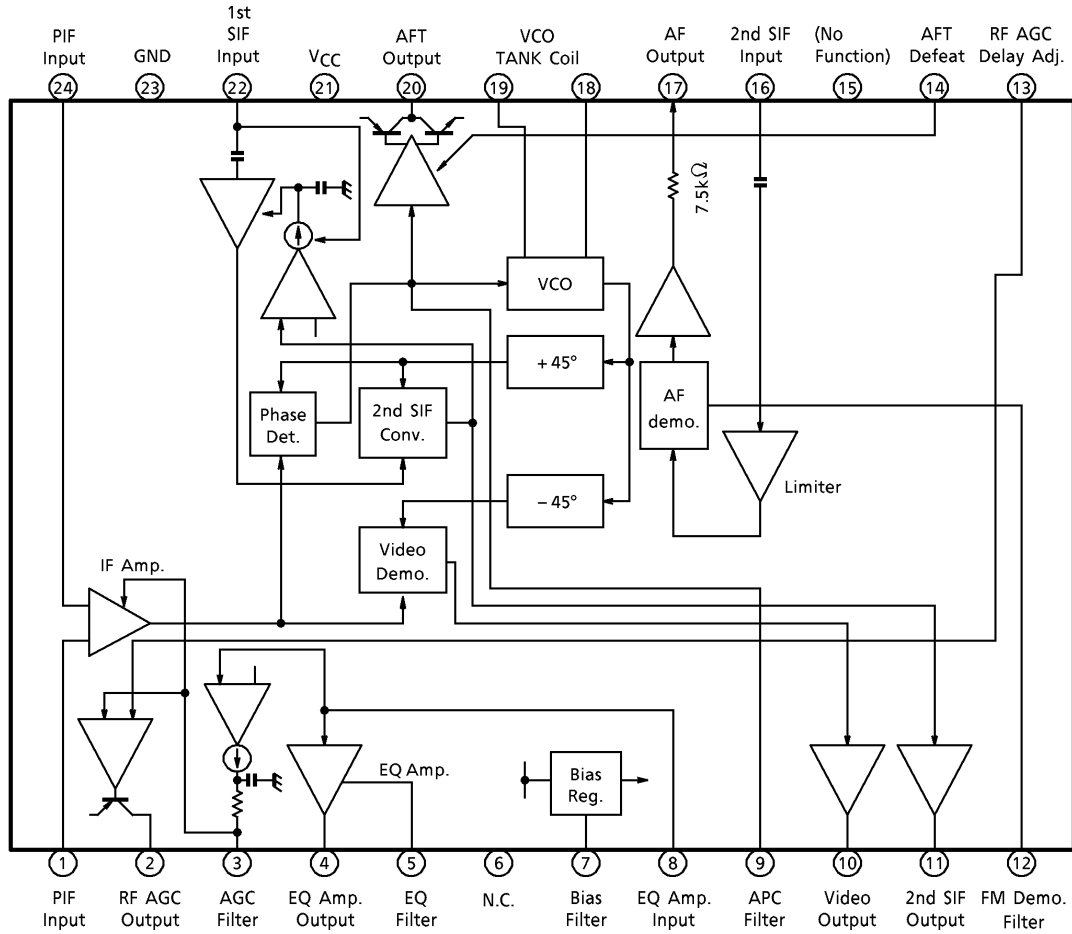

TERMINAL FUNCTION

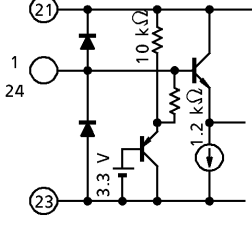
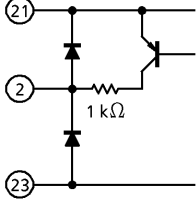
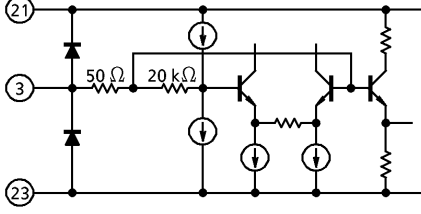
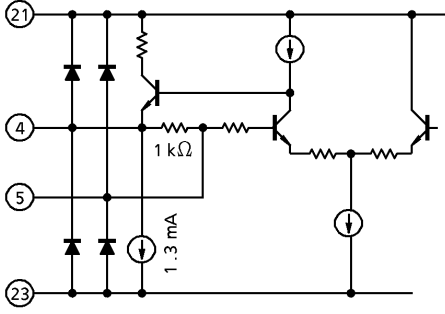
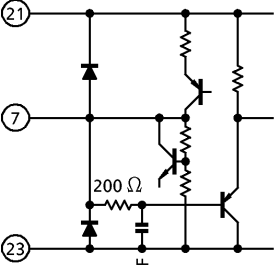
PIN No.	NAME	FUNCTION	INTERFACE CIRCUIT
1 24	PIF input	Differential type inputs Typical input level is 85 dB μ V.	
2	RF AGC output	Open collector (PNP) type output. Maximum output current is 0.5 mA.	
3	AGC filter	Connect a capacitor (0.47 μ F) between GND.	
4 5	EQ amplifier output EQ filter	No.4 terminal is EQ amplifier output. Maximum output current of this terminal is 5 mA. No.5 terminal is for EQ filter.	
6	N.C.		—
7	Bias filter	Connect a capacitor (10 μ F) between GND.	

10

PIN No.	NAME	FUNCTION	INTERFACE CIRCUIT
8	EQ amplifier input	EQ amplifier inputs.	
9	APC filter	Connect a resistor (330 Ω) and a capacitor (0.47 μF) between GND in series. And connect a capacitor (1000 pF) between this terminal and GND. Sensitivity of phase detector is 400 μA/rad (Typ.), and sensitivity of VCO is 1.8 MHz/V (Typ.).	
10	Video output	Connect a resistor (1 kΩ) between GND. Maximum output current is 10 mA.	
11	2 nd SIF output	2 nd SIF signal is outputted from this terminal.	
12	FM demodulating filter	Connect a capacitor (2.2 μF) between GND.	

PIN No.	NAME	FUNCTION	INTERFACE CIRCUIT
13	RF AGC delay adj.	This terminal is for RF AGC delay point adjustment. 100 μ A current is outputted from this terminal. Connect a resistor (5.6 k Ω) and a volume (10 k Ω) between GND in series.	
14	AFT Defeat SW	This terminal is AFT defeat switch. To open this terminal, AFT function is activate. To connect GND this terminal, AFT function is not activate. And terminal No.20 goes to 1/2 V _{CC} .	
15	(No function)	This terminal must be connected to V _{CC} .	—
16	2 nd SIF input	This terminal 2 nd SIF input. This terminal must be decoupled outer circuit on D.C.	
17	AF output	Output resistance of this terminal is 7.5 k Ω .	
18 19	VCO tank	Connect tank for VCO between these terminals. Capacitance of the VCO tank is 27 pF.	

PIN No.	NAME	FUNCTION	INTERFACE CIRCUIT
20	AFT output	Push-pull type current output. Reverse type AFT.	
21	V _{CC}	Recommended voltage range is 9.0 V ± 10%.	—
22	SIF input	In use inter-carrier application, connect this terminal to GND. In this condition, the SIF amplifier sets gain minimum.	
23	GND	—	—

MAXIMUM RATINGS (Ta = 25°C)

CHARACTERISTIC	SYMBOL	RATING	UNIT
Supply Voltage	V _{CC}	13	V
Power Dissipation	P _{D max}	1040 (Note 1)	mW
Operating Temperature	T _{opr}	-20~75	°C
Storage Temperature	T _{stg}	-55~150	°C

(Note 1) : This value is on condition that the IC is mounted on PCB (50 mm x 50 mm). When using the device at Ta = 25°C, decrease the power dissipation by 8.3 mW for each increase of 1°C.

RECOMMENDED SUPPLY VOLTAGE

PIN No.	PIN NAME	MIN.	TYP.	MAX.	UNIT
21	V _{CC}	8.1	9.0	9.9	V

ELECTRICAL CHARACTERISTICS

DC current characteristics (V_{CC} = 9.0 V, Ta = 25°C)

PIN No.	PIN NAME	SYMBOL	MIN.	TYP.	MAX.	UNIT
21	V _{CC}	I _{CC}	36	45	60	mA

DC voltage characteristics (V_{CC} = 9.0 V, Ta = 25°C)

PIN No.	SYMBOL	TEST CIR-CUIT	TEST CONDITION	MIN.	TYP.	MAX.	UNIT
1	V ₁	—	—	3.5	4.0	4.5	V
4	V ₄	—	No signal input	4.7	5.2	5.7	
5	V ₅	—	—	4.7	5.2	5.7	
7	V ₇	—	—	6.3	7.0	7.7	
10	V ₁₀	—	No signal input	4.7	5.2	5.7	
11	V ₁₁	—	—	3.1	3.5	3.9	
14	V ₁₄	—	—	2.5	3.1	3.7	
15	V ₁₅	—	—	2.5	3.1	3.7	
16	V ₁₆	—	—	2.5	3.1	3.7	
17	V ₁₇	—	2nd SIF 4.5 MHz	3.2	3.7	4.2	
18	V ₁₈	—	—	7.2	7.6	7.9	
19	V ₁₉	—	—	7.2	7.6	7.9	
20	V ₂₀	—	In AFT defeat	4.3	4.5	4.7	
22	V ₂₂	—	—	4.9	5.3	5.7	
24	V ₂₄	—	—	3.5	4.0	4.5	

AC CHARACTERISTICS ($V_{CC} = 9.0\text{ V}$, $T_a = 25^\circ\text{C}$)

PIF section

CHARACTERISTIC	SYMBOL	TEST CIR-CUIT	TEST CONDITION	MIN.	TYP.	MAX.	UNIT
PIF Input Sensitivity	$v_{in\ min(p)}$	—	(Note 1)	—	40	45	$\text{dB}\mu\text{V}$
PIF Maximum Input Signal	$v_{in\ max(p)}$	—		105	113	—	
PIF Gain Control Range	$R_{AGC(p)}$	—		68	73	—	
RF AGC Maximum Output Voltage	$V_{AGC\ max}$	—	(Note 2)	8.5	8.9	—	V
RF AGC Minimum Output Voltage	$V_{AGC\ min}$	—		—	0.0	0.1	V
PIF Input Resistance (*)	$Z_{in\ R(p)}$	—	(Note 3)	—	1.2	—	$\text{k}\Omega$
PIF Input Capacitance (*)	$Z_{in\ C(p)}$	—		—	3.6	—	pF
Differential Gain	DG	—	(Note 4)	—	1.0	3.0	%
Differential Phase	DP	—		—	3.0	5.0	deg
Intermodulation	I_M	—	(Note 5)	50	55	—	dB
Video Output Signal Amplitude	$v_{Det(p)}$	—	(Note 6)	2.0	2.2	2.4	V
Video Output S/N	S/N (p)	—	(Note 7)	55	60	—	dB
Synchronous Signal Level	V_{sync}	—	(Note 8)	2.4	2.7	3.0	V
Threshold Level of the Black Noise Inverter	V_{thB}	—	(Note 9)	1.7	2.0	2.3	
Clamp Level of the Black Noise Inverter	V_{cpB}	—		3.3	3.6	3.9	
Video Bandwidth (–3 dB)	$f_{Det(p)}$	—	(Note 10)	6	8	10	MHz
Capture Range of the PLL (Upper)	$f_{p(p)H}$	—	(Note 11)	1.8	2.3	—	MHz
Capture Range of the PLL (Lower)	$f_{p(p)L}$	—		—	–2.0	–1.5	
Hold Range of the PLL (Upper)	$f_{h(p)H}$	—		1.8	2.3	—	
Hold Range of the PLL (Lower)	$f_{h(p)L}$	—		—	–2.0	–1.5	
Control Steepness of the VCO	β	—	(Note 12)	—	1.8	—	MHz/V
Steepness of the AFT Detection	S_{AFT}	—	(Note 13)	15	20	25	kHz/V
AFT Maximum Output Voltage	$V_{AFT\ max}$	—		8.5	8.8	—	V
AFT Minimum Output Voltage	$V_{AFT\ min}$	—		—	0.4	0.6	
AFT Output Voltage On Defeating	$V_{AFT\ Def}$	—	(Note 14)	4.3	4.5	4.7	

(*) : Not tested

SIF section

CHARACTERISTIC	SYMBOL	TEST CIR-CUIT	TEST CONDITION	MIN.	TYP.	MAX.	UNIT
SIF Maximum Input Signal	$v_{in \max}$ (s)	—	(Note 15)	105	118	—	$\text{dB}\mu\text{V}$
SIF Gain Control Range	R_{AGC} (s)	—		55	75	—	dB
SIF Input Resistance (*)	$Z_{in R}$ (s)	—	(Note 16)	—	10	—	$\text{k}\Omega$
SIF Input Capacitance (*)	$Z_{in C}$ (s)	—		—	2.8	—	pF
Limiting Sensitivity	$v_{in \text{ lim}}$	—	(Note 17)	—	40	45	$\text{dB}\mu\text{V}$
AM Reduction Ratio	AMR	—	(Note 18)	55	68	—	dB
AF Output Signal Amplitude	V_{Det} (s)	—	(Note 19)	350	500	710	mV_{rms}
AF Output S/N	S/N (s)	—		55	63	—	dB
Total Harmonics Distortion	THD	—		—	0.2	1.0	%
Hold Range of the FM Demodulator (Lower)	f_h (s) L	—	(Note 20)	—	—	3.9	MHz
Hold Range of the FM Demodulator (Upper)	f_h (s) H	—		5.3	—	—	
Capture Range of the FM Demodulator (Upper)	f_p (s) H	—	(Note 21)	—	—	4.0	MHz
Capture Range of the FM Demodulator (Lower)	f_p (s) L	—		5.2	—	—	
Ripple Rejection	RR	—	(Note 22)	—	—	-22	dB

(*) : Not tested

MEASUREMENTS
PIF section

		TEST CONDITION									
NOTE	INPUT MEAS. POINT	SW3	SW8	VR13	SW14 b	SW17	SW22				
Note 1	J1 TP10	OFF	ON	—	OFF	ON	ON				<p>Input the signal (Frequency : 45.75 MHz, Amplitude : 85 dBμV, 15 kHz sine wave/30% AM) to J1.</p> <p>Change amplitude of the input signal, and measure amplitude of the output signal at TP10.</p> <p>Calculate RAGC (p) show as below.</p>
Note 2	J1 TP2	OFF	ON	Min. Max.	OFF	ON	ON				<p>Input the signal (Frequency : 45.75 MHz, Amplitude : 85 dBμV, 15 kHz sine wave/30% AM) to J1.</p> <p>Set VR13 to the minimum.</p> <p>Measure voltage at TP 2 (VAGC max V.)</p> <p>Set VR13 to the maximum.</p> <p>Measure voltage at TP 2 (VAGC min V.)</p>
Note 3	— TP1 TP24	OFF	ON	—	OFF	ON	ON				<p>Remove all connections from terminal 1 and terminal 24.</p> <p>Measure resistance (Zin R (p) kΩ) and capacitance (Zin C (p) pF) of TP1 and TP24 by the impedance meter.</p>

NOTE	TEST CONDITION										
	INPUT POINT	MEAS. POINT	SW3	SW8	VR13	SW14 _b			SW17	SW22	
Note 4	J1	TP4	OFF	ON	—	OFF			ON	ON	<ul style="list-style-type: none"> Input the signal (Frequency : 45.75 MHz, Amplitude : 85 dBμV, amplitude modulated by 10 step signal) to J1. Measure DG and DP at TP4.
Note 5	J1	TP4	OFF	ON	—	OFF			ON	ON	<ul style="list-style-type: none"> Input the signal (Frequency : 45.75 MHz, Amplitude : 85 dBμV, 15 kHz sine wave / 30% AM) from J1. Measure the minimum voltage of the output signal at TP4 (Vmin). Input the mixture of 3 signals (signal 1 Frequency : 45.75 MHz, Amplitude : 85 dBμV, signal 2 Frequency : 42.17 MHz, Amplitude : 75 dBμV, and signal 3 Frequency : 41.25 MHz, Amplitude : 75 dBμV) to J1. Apply DC voltage to TP3 and adjust it so that the bottom of the output signal at TP4 is equal to Vmin. Measure frequency spectrum of the output signal at TP4.

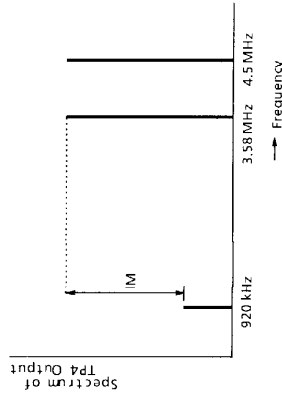

NOTE	TEST CONDITION									
	INPUT POINT	MEAS. POINT	SW3	SW8	VR13	SW14 _b	SW17	SW22		
Note 6	J1	TP4	OFF	ON	—	OFF	ON	ON	<ul style="list-style-type: none"> Input the signal (Frequency : 45.75 MHz, Amplitude : 85 dBμV, amplitude modulated by 100 IRE white picture) to J1. Measure amplitude of the output signal at TP4 (V_{Det} (p) V). 	
Note 7	J1	TP4	OFF	ON	—	OFF	ON	ON	<ul style="list-style-type: none"> Input the signal (Frequency : 45.75 MHz, Amplitude : 85 dBμV, amplitude modulated by black picture) to J1. Measure video S/N at TP4 (HPF : 100 kHz, LPF : 4.2 MHz, CCIR Weighted) (S/N (p) dB). 	
Note 8	J1	TP4	OFF	ON	—	OFF	ON	ON	<ul style="list-style-type: none"> Input the signal (Frequency : 45.75 MHz, Amplitude : 85 dBμV, amplitude modulated by 100 IRE white picture) to J1. Measure voltage of the sync. tip at TP4 (vsync V) 	
Note 9	J1	TP4	OFF	ON	—	OFF	ON	ON	<ul style="list-style-type: none"> Input the signal (Frequency : 45.75 MHz, Amplitude : 85 dBμV, 15 kHz triangle wave / 50% AM) to J1. Apply DC voltage to TP3 and adjust it to get the waveform shown as below at TP4. Measure V_{thB} V and V_{cpB} V at TP4. 	

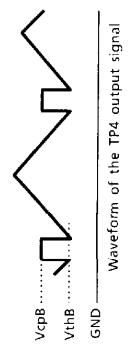

TEST CONDITION									
NOTE	INPUT POINT	MEAS. POINT	SW3	SW8	V _{R13}	SW _{14b}	SW17	SW22	
Note 10	J1	TP4	OFF	ON	—	OFF	ON	ON	<p>● Input the mixture of 2 signals (signal 1 Frequency : 45.75 MHz, Amplitude : 82 dBμV, signal 2 Frequency : 45.65 MHz, Amplitude : 69 dBμV to J1.</p> <p>● Measure the minimum voltage of the output signal at TP4 (VoTP4).</p> <p>● Apply DC voltage to TP3 and adjust it so that the minimum voltage of the output signal at TP4 is equal to VoTP4.</p> <p>● Decrease frequency of the input signal at J1, and measure amplitude of the output signal at TP4.</p> <p>● Measure f Det (p) show as below.</p>

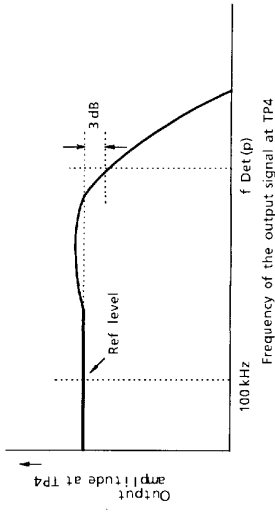

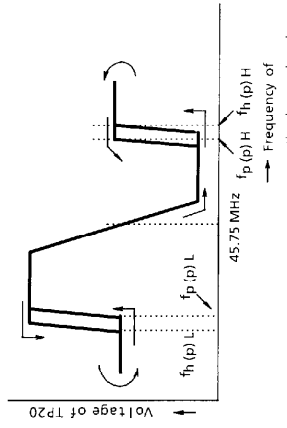
TEST CONDITION									
NOTE	INPUT POINT	MEAS. POINT	SW3	SW8	V _{R13}	SW _{14b}	SW17	SW22	
Note 11	J1	TP20	OFF	ON	—	OFF	ON	ON	<ul style="list-style-type: none"> Input the signal (Frequency : 45.75 MHz, Amplitude : 85 dBμV) to J1. Sweep down the input signal frequency to 41.75 MHz, and sweep up to 49.75 MHz. Sweep down the input signal frequency to 45.75 MHz. Measure the voltage at TP20. 
Note 12	TP9	Pin 18 Pin 19	OFF	ON	—	OFF	ON	ON	<ul style="list-style-type: none"> Set the FET probe which connected to the spectrum analyzer near by pin 18 or pin 19 (Don't touch the probe directly to pin 18 or to pin 19). Apply 4.3 V to TP9, and measure frequency of the VCO oscillation by the spectrum analyzer (f_{LVCO} MHz). Apply 4.7 V to TP9, and measure frequency of the VCO oscillation by the spectrum analyzer (f_{HVCO} MHz). β MHz/V = (f_{HVCO} - f_{LVCO}) / 0.4

NOTE	TEST CONDITION									
	INPUT POINT	MEAS. POINT	SW3	SW8	VR13	SW14 _b	SW17	SW22		
Note 13	J1	TP20	OFF	ON	—	OFF	ON	ON	<ul style="list-style-type: none"> ● Input the signal (Frequency : 45.75 MHz — 20 kHz, Amplitude : 85 dBμV) to J1. ● Measure voltage at TP20 (V_HTP20 V). ● Input the signal (Frequency : 45.75 MHz + 20 kHz, Amplitude : 85 dBμV) to J1. ● Measure voltage at TP20 (V_LTP20 V). ● S AFT kHz/V = 40 / (V_HTP20 — V_LTP20) ● Input the signal (Frequency : 45.75 MHz — 500 kHz, Amplitude : 85 dBμV) to J1. ● Measure voltage at TP20 (VAFT max V). ● Input the signal (Frequency : 45.75 MHz + 500 kHz, Amplitude : 85 dBμV) to J1. ● Measure voltage at TP20 (VAFT min V). 	
Note 14	—	TP20	OFF	ON	—	ON	ON	ON	<ul style="list-style-type: none"> ● Measure voltage at TP20 (VAFT Def V). 	

SIF section

NOTE		INPUT POINT	MEAS. POINT	SW3	SW8	VR13	SW14 _b	TEST CONDITION			SW17	SW22
Note 15	J1 J2	TP11	OFF	ON	—	OFF					ON	OFF
Note 16	—	TP22	ON	ON	—	OFF					ON	—
Note 17	J3	TP17	ON	ON	—	OFF					ON	ON

- Input the signal (Frequency : 45.75 MHz, Amplitude : 85 dB μ V) to J1, and input the signal (Frequency : 41.25 MHz, Amplitude : 75 dB μ V) to J2.
- Change the amplitude of the signal at J2, and measure amplitude of the output signal at TP11.

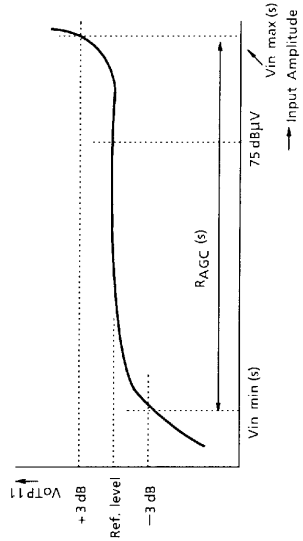

- Remove all connections from terminal 22.
- Measure resistance (Zin R (s) k Ω and capacitance (Zin C (s) pF) of TP1 and TP24 by the impedance meter.
- Input the signal (Frequency : 4.5 MHz, Amplitude : 100 dB μ V, 400 Hz sine wave / 25 kHz Devi FM) to J3.
- Measure amplitude of the output signal at TP17 (voTP17).
- Measure the input signal amplitude when the output amplitude from TP17 becomes -3 dB of voTP17, by decreasing the input signal amplitude to J3 (vin lim dB μ V).

TA1274F—16

TEST CONDITION									
NOTE	INPUT MEAS. POINT	SW3	SW8	VR13	SW14 _b	SW17	SW22		
Note 18	J3 TP17	ON	ON	—	OFF	ON	ON	<ul style="list-style-type: none"> Input the signal (Frequency : 4.5 MHz, Amplitude : 100 dBμV, 400 Hz sine wave / 25 kHz Devi FM) to J3. Measure amplitude of the output signal at TP17 (VFM TP17 mVrms). Input the signal (Frequency : 4.5 MHz, Amplitude : 100 dBμV, 400 Hz sine wave / 30% AM) to J3. Measure amplitude of the output signal at TP17 (VAM TP17 mVrms). AMR4.5 dB = 20 \log (VFM TP17 / VAM TP17) Input the signal (Frequency : 4.5 MHz, Amplitude : 100 dBμV, 400 Hz sine wave / 25 kHz Devi FM) to J3. Measure amplitude of the output signal at TP17 (vDet (s) 4.5L mVrms). Measure distortion of the TP17 output (THD4.5L %). Input the signal (Frequency : 4.5 MHz, Amplitude : 100 dBμV to J3. Measure amplitude of the output signal at TP17 (vN TP17 mVrms). S / N4.5 = 20 \log (vDet (s) 4.5 / vN TP17) Input the signal (Frequency : 4.5 MHz, Amplitude : 100 dBμV to J3. Change the frequency of the input signal, and measure voltage at TP12. 	
Note 19	J3 TP17	ON	ON	—	OFF	ON	ON		
Note 20	J3 TP12	ON	ON	—	OFF	ON	ON		

TA1274F—17

		TEST CONDITION									
NOTE	INPUT POINT	MEAS. POINT	SW3	SW8	V _{R13}	SW _{14b}	SW17	SW22			
Note 21	J3	TP12	ON	ON	—	OFF	ON	ON	<ul style="list-style-type: none"> • Input the signal (Frequency : 1 MHz, Amplitude : 100 dBμV) to J3. • Increase frequency of the input signal. • Measure voltage of TP12 (VTP120 V). • Apply 5 V to TP12. • Stop applying 5 V to TP12. • Measure voltage of TP12 (VTP121 V). • Measure frequency of the input signal when VTP120 = VTP121 (f_{p(s)L} MHz). • Input the signal (Frequency : 10 MHz, Amplitude : 100 dBμV) to J3. • Decrease frequency of the input signal. • Measure voltage of TP12 (VTP122 V). • Connect TP12 to GND. • Open TP12. • Measure voltage of TP12 (VTP123 V). • Measure frequency of the input signal when VTP122 = VTP123 (f_{p(s)H} MHz). 		
Note 22	J3	TP17	ON	ON	—	OFF	ON	ON	<ul style="list-style-type: none"> • Input the signal (DC 9 V + AC Frequency : 60 Hz, Amplitude : 100 mV_{p-p}) to V_{CC} terminal. • Input the signal (Frequency : 1 MHz, Amplitude : 100 dBμV) to J3. • Measure amplitude of TP17 (VTP17 mV_{p-p}). • RR dB = 20 log (VTP17 / 100) 		

APPLICATION CIRCUIT

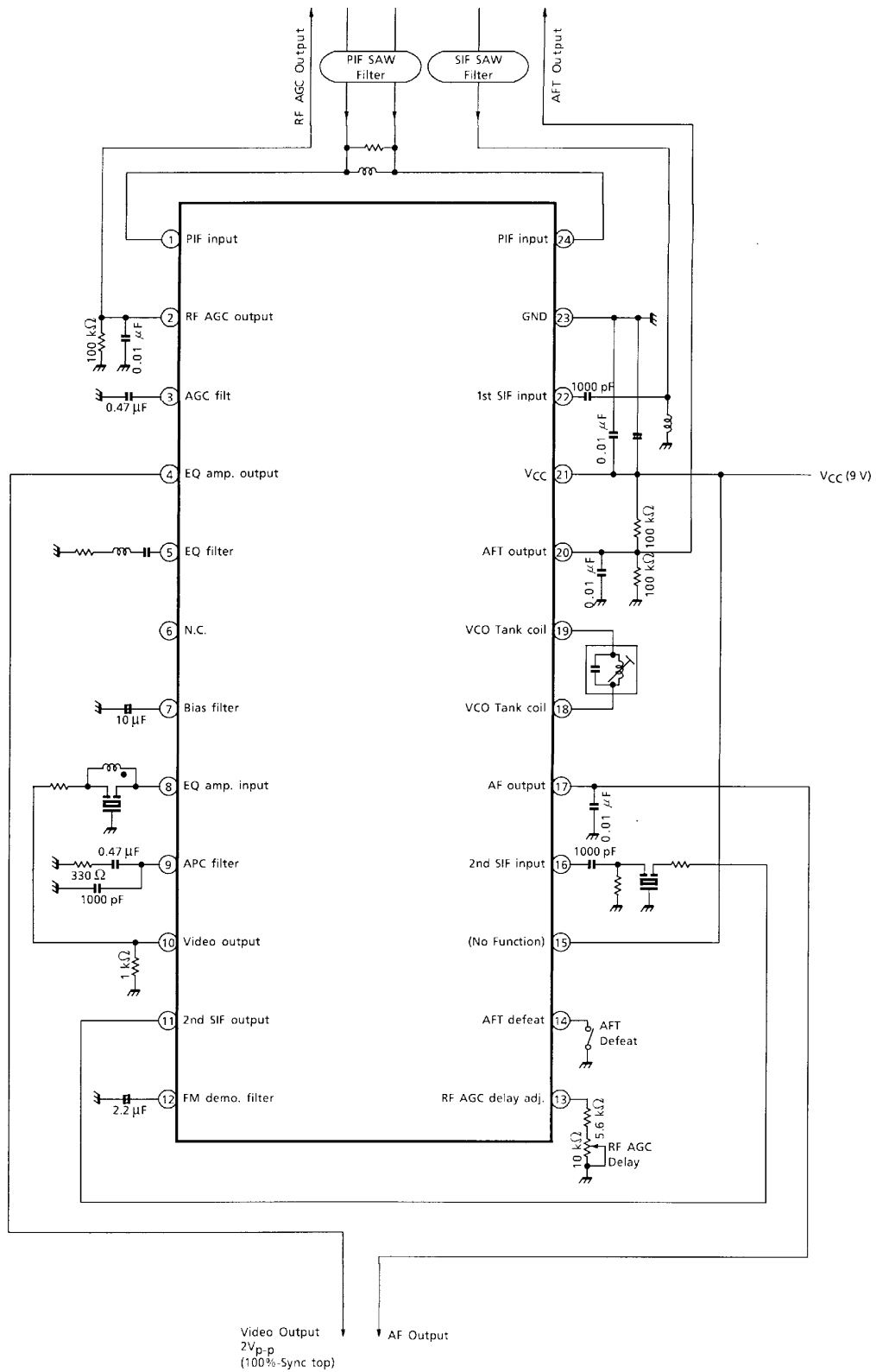

PACKAGE DIMENSIONS
SSOP24-P-300-1.00B

Unit : mm

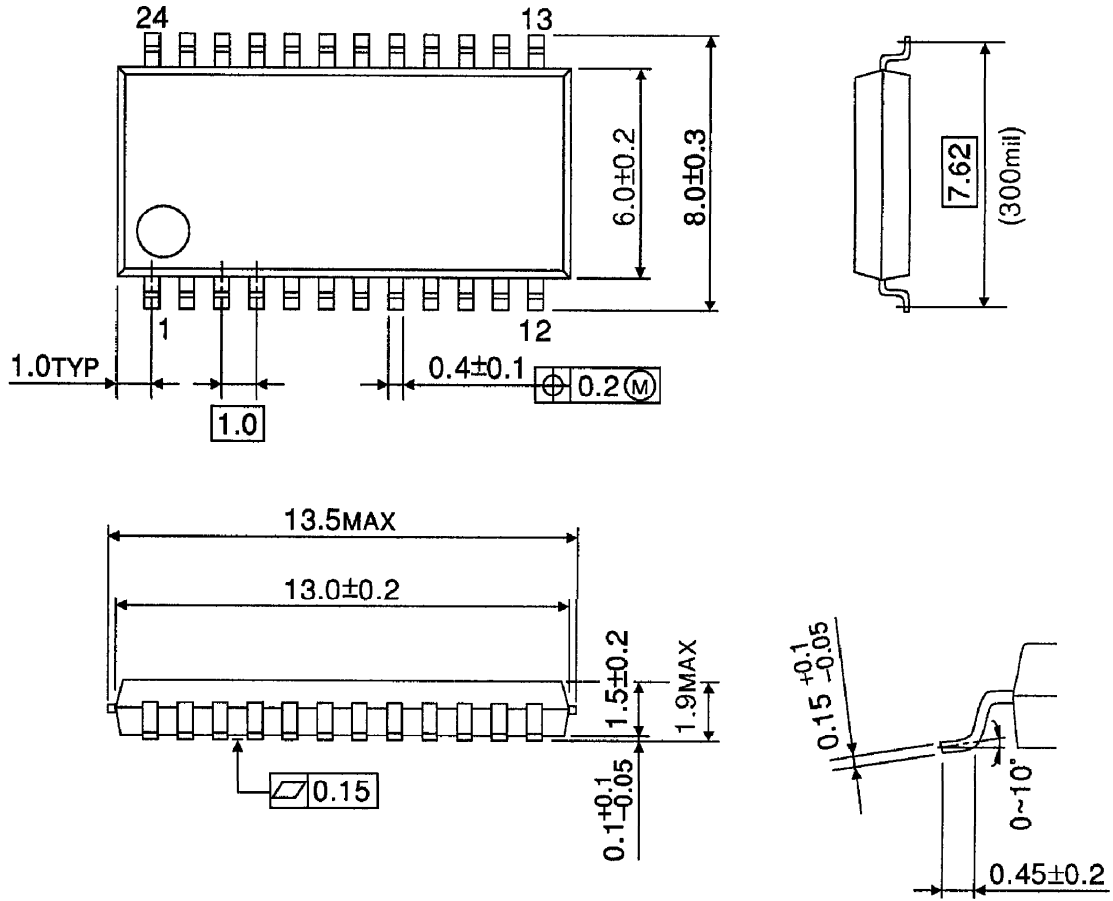

Weight : 0.27 g (Typ.)