

Document Title

1Mx36 & 2Mx18-Bit Synchronous Pipelined Burst SRAM

Revision History

<u>Rev. No.</u>	<u>History</u>	<u>Draft Date</u>	<u>Remark</u>
0.0	1. Initial draft	May. 10. 2001	Advance
0.1	1. Add 165FBGA package	Aug. 29. 2001	Preliminary
0.2	1. Update JTAG scan order 2. Speed bin merge. From K7A3236(18)09M to K7A3236(18)00M. 3. AC parameter change. tOH(min)/tHZC(min) from 0.8 to 1.5 at -25 tOH(min)/tHZC(min) from 1.0 to 1.5 at -22 tOH(min)/tHZC(min) from 1.0 to 1.5 at -20	Dec. 31. 2001	Preliminary
0.3	1. Change pin out for 165FBGA - x18/x36 ; 11B => from A to NC , 2R ==> from NC to A .	Feb. 14. 2002	Preliminary
0.4	1. Insert pin at JTAG scan order of 165FBGA in connection with pin out change - x18/x36 ; insert Pin ID of 2R to BIT number of 69	Apr. 20. 2002	Preliminary
0.5	1. Add lcc, lsb, lsb1 and lsb2 values	May.10. 2002	Preliminary
1.0	1. Correct the pin name of 100TQFP.	Oct. 15. 2002	Final
1.1	1. Add the Industrial temperature range.	Mar. 19, 2003	Final
1.2	1. Change the Stand-by current (lsb) Before After lsb - 25 : 120 170 - 22 : 110 160 - 20 : 100 150 - 16 : 90 140 - 15 : 90 140 - 14 : 90 140 lsb1 : 90 110 lsb2 : 80 100	Oct. 17, 2003	Final
2.0	1. Delete the 119BGA and 165FBGA package. 2. Delete the 225MHz, 167MHz and 150MHz speed bin	Nov. 18, 2003	Final

The attached data sheets are prepared and approved by SAMSUNG Electronics. SAMSUNG Electronics CO., LTD. reserve the right to change the specifications. SAMSUNG Electronics will evaluate and reply to your requests and questions on the parameters of this device. If you have any questions, please contact the SAMSUNG branch office near your office, call or contact Headquarters.

**K7A323600M
K7A321800M**

1Mx36 & 2Mx18 Synchronous SRAM

32Mb SB/SPB Synchronous SRAM Ordering Information

Org.	Part Number	Mode	VDD	Speed SB ; Access Time(ns) SPB ; Cycle Time(MHz)	PKG	Temp
2Mx18	K7B321825M-QC65/75	SB	3.3	6.5/7.5ns	Q: 100TQFP	C ; Commercial Temp.Range I ; Industrial Temp.Range
	K7A321800M-QC(I)25/20/14	SPB(2E1D)	3.3	250/200/138MHz		
1Mx36	K7B323625M-Q)C65/75	SB	3.3	6.5/7.5ns		
	K7A323600M-QC(I)25/20/14	SPB(2E1D)	3.3	250/200/138MHz		

1Mx36 & 2Mx18-Bit Synchronous Pipelined Burst SRAM

FEATURES

- Synchronous Operation.
- 2 Stage Pipelined operation with 4 Burst.
- On-Chip Address Counter.
- Self-Timed Write Cycle.
- On-Chip Address and Control Registers.
- $V_{DD} = 3.3V \pm 0.165V / -0.165V$ Power Supply.
- I/O Supply Voltage $3.3V \pm 0.165V / -0.165V$ for 3.3V I/O or $2.5V \pm 0.4V / -0.125V$ for 2.5V I/O.
- 5V Tolerant Inputs Except I/O Pins.
- Byte Writable Function.
- Global Write Enable Controls a full bus-width write.
- Power Down State via ZZ Signal.
- \overline{LBO} Pin allows a choice of either a interleaved burst or a linear burst.
- Three Chip Enables for simple depth expansion with No Data Contention only for TQFP ; 2cycle Enable, 1cycle Disable.
- Asynchronous Output Enable Control.
- \overline{ADSP} , \overline{ADSC} , \overline{ADV} Burst Control Pins.
- TTL-Level Three-State Output.
- 100-TQFP-1420A Package
- Operating in commercial and industrial temperature range.

GENERAL DESCRIPTION

The K7A323600M and K7A321800M are 37,748,736-bit Synchronous Static Random Access Memory designed for high performance second level cache of Pentium and Power PC based System.

It is organized as 1M(2M) words of 36(18) bits and integrates address and control registers, a 2-bit burst address counter and added some new functions for high performance cache RAM applications; \overline{GW} , \overline{BW} , \overline{LBO} , \overline{ZZ} . Write cycles are internally self-timed and synchronous.

Full bus-width write is done by \overline{GW} , and each byte write is performed by the combination of \overline{WEx} and \overline{BW} when \overline{GW} is high. And with $\overline{CS1}$ high, \overline{ADSP} is blocked to control signals.

Burst cycle can be initiated with either the address status processor (\overline{ADSP}) or address status cache controller (\overline{ADSC}) inputs. Subsequent burst addresses are generated internally in the system's burst sequence and are controlled by the burst address advance (\overline{ADV}) input. \overline{LBO} pin is DC operated and determines burst sequence (linear or interleaved).

\overline{ZZ} pin controls Power Down State and reduces Stand-by current regardless of CLK.

The K7A323600M and K7A321800M are fabricated using SAMSUNG's high performance CMOS technology and is available in a 100pin TQFP package. Multiple power and ground pins are utilized to minimize ground bounce.

FAST ACCESS TIMES

PARAMETER	Symbol	-25	-20	-14	Unit
Cycle Time	tCYC	4.0	5.0	7.2	ns
Clock Access Time	tCD	2.6	3.1	4.0	ns
Output Enable Access Time	tOE	2.6	3.1	4.0	ns

LOGIC BLOCK DIAGRAM

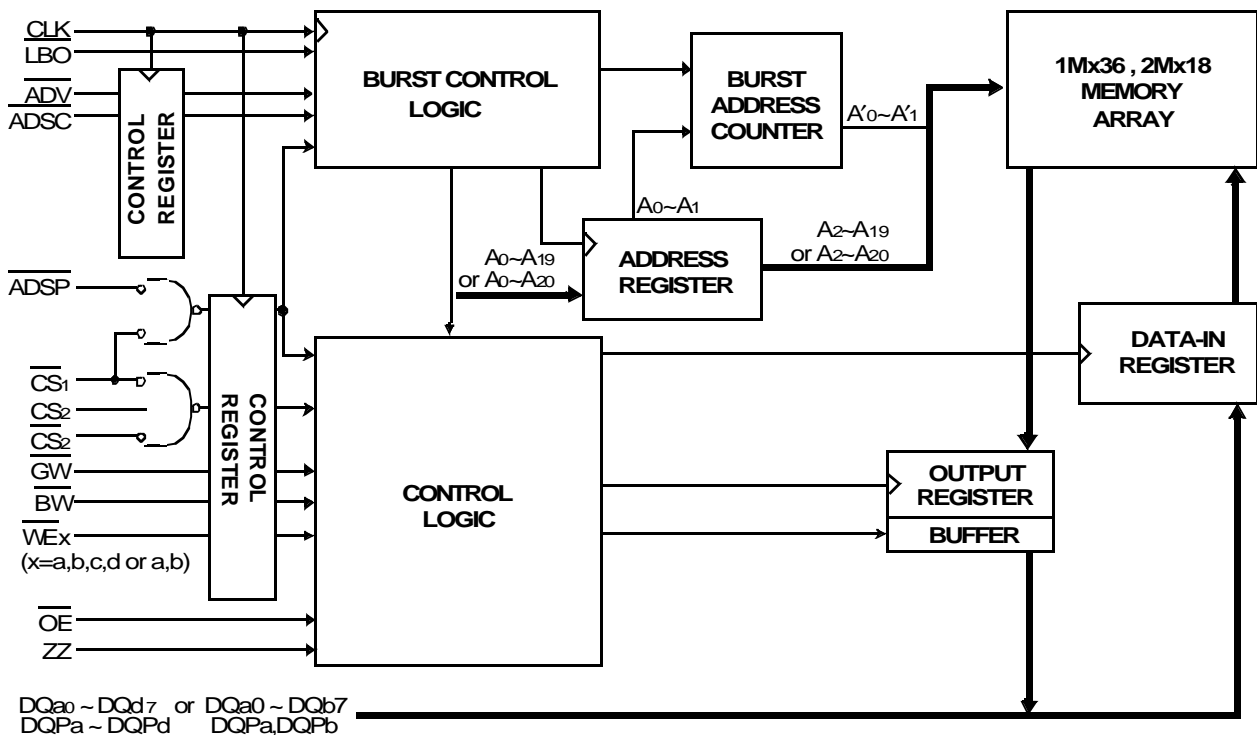

DQa0 ~ DQd7 or DQa0 ~ DQb7
DQPa ~ DQPd DQPa, DQPb

**K7A323600M
K7A321800M**

1Mx36 & 2Mx18 Synchronous SRAM

PIN CONFIGURATION(TOP VIEW)

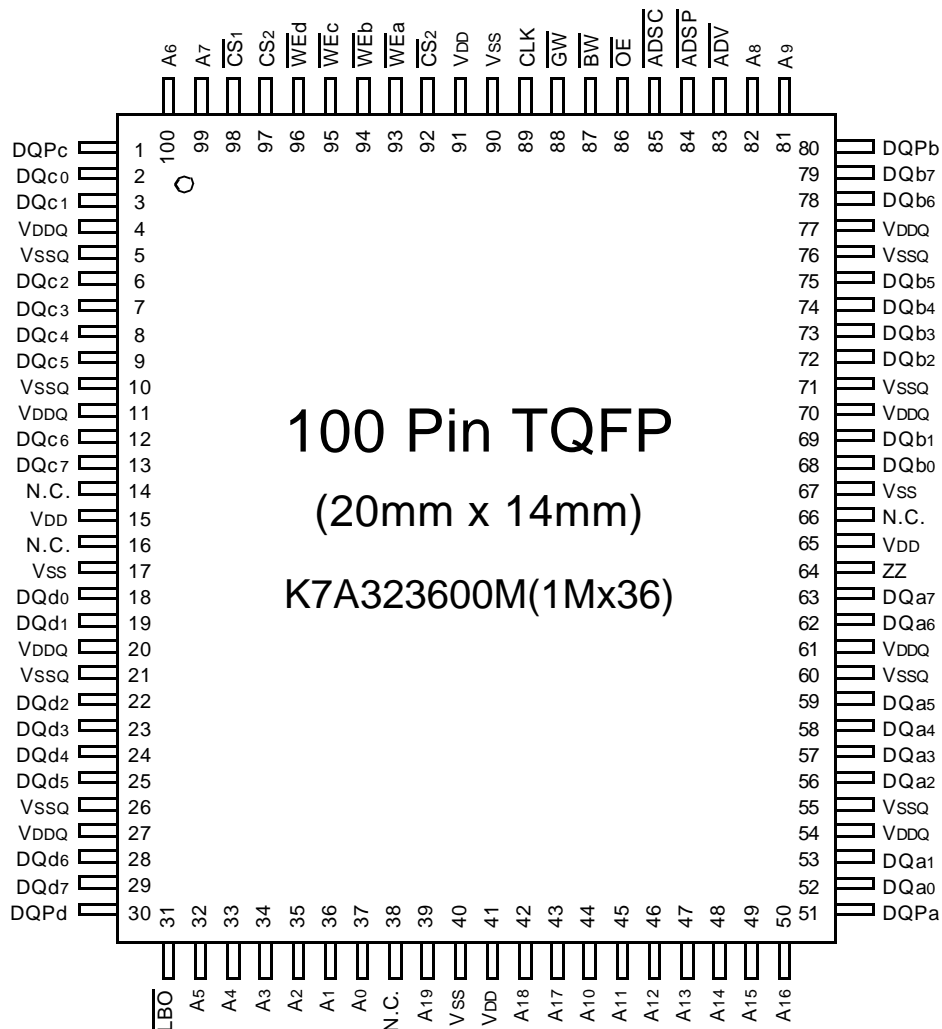

PIN NAME

SYMBOL	PIN NAME	TQFP PIN NO.	SYMBOL	PIN NAME	TQFP PIN NO.
A0 - A19	Address Inputs	32,33,34,35,36,37,39 42,43,44,45,46,47,48, 49,50,81,82,99,100	VDD	Power Supply(+3.3V)	15,41,65,91
			Vss	Ground	17,40,67,90
ADV	Burst Address Advance	83	N.C.	No Connect	14,16,38,66
ADSP	Address Status Processor	84			
ADSC	Address Status Controller	85	DQa0~a7	Data Inputs/Outputs	52,53,56,57,58,59,62,63
CLK	Clock	89	DQb0~b7		68,69,72,73,74,75,78,79
CS1	Chip Select	98	DQc0~c7		2,3,6,7,8,9,12,13
CS2	Chip Select	97	DQd0~d7		18,19,22,23,24,25,28,29
CS2	Chip Select	92	DQPa~Pd		51,80,1,30
WE _x (x=a,b,c,d)	Byte Write Inputs	93,94,95,96	VDDQ	Output Power Supply (3.3V or 2.5V)	4,11,20,27,54,61,70,77
OE	Output Enable	86	VSSQ	Output Ground	5,10,21,26,55,60,71,76
GW	Global Write Enable	88			
BW	Byte Write Enable	87			
ZZ	Power Down Input	64			
LBO	Burst Mode Control	31			

Note : 1. A0 and A1 are the two least significant bits(LSB) of the address field and set the internal burst counter if burst is desired.

**K7A323600M
K7A321800M**

1Mx36 & 2Mx18 Synchronous SRAM

PIN CONFIGURATION(TOP VIEW)

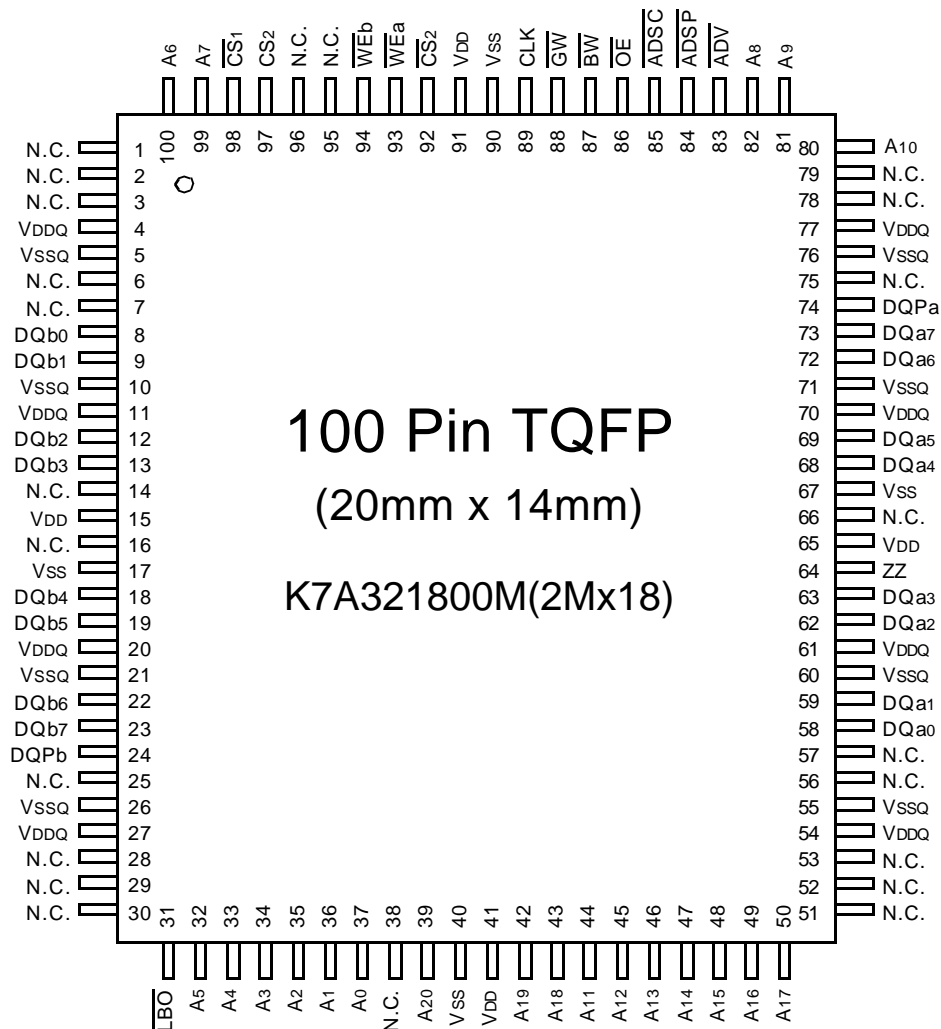

PIN NAME

SYMBOL	PIN NAME	TQFP PIN NO.	SYMBOL	PIN NAME	TQFP PIN NO.
A0 - A20	Address Inputs	32,33,34,35,36,37,39 42,43,44,45,46,47,48, 49,50,80,81,82,99,100	VDD	Power Supply(+3.3V)	15,41,65,91
			VSS	Ground	17,40,67,90
<u>ADV</u>	Burst Address Advance	83	N.C.	No Connect	1,2,3,6,7,14,16,25,28,29 30,38,51,52,53,56,57 66,75,78,79,95,96
<u>ADSP</u>	Address Status Processor	84			
<u>ADSC</u>	Address Status Controller	85			
CLK	Clock	89			
<u>CS1</u>	Chip Select	98	DQa0 ~ a7	Data Inputs/Outputs	58,59,62,63,68,69,72,73
<u>CS2</u>	Chip Select	97	DQb0 ~ b7		8,9,12,13,18,19,22,23
<u>CS2</u>	Chip Select	92	DQPa, Pb		74,24
<u>WE</u> (x=a,b)	Byte Write Inputs	93,94	VDDQ	Output Power Supply (3.3V or 2.5V)	4,11,20,27,54,61,70,77
<u>OE</u>	Output Enable	86	VSSQ	Output Ground	5,10,21,26,55,60,71,76
<u>GW</u>	Global Write Enable	88			
<u>BW</u>	Byte Write Enable	87			
<u>ZZ</u>	Power Down Input	64			
<u>LBO</u>	Burst Mode Control	31			

Note : 1. A₀ and A₁ are the two least significant bits(LSB) of the address field and set the internal burst counter if burst is desired.

FUNCTION DESCRIPTION

The K7A323600M and K7A321800M are synchronous SRAM designed to support the burst address accessing sequence of the Power PC based microprocessor. All inputs (with the exception of \overline{OE} , \overline{LBO} and \overline{ZZ}) are sampled on rising clock edges. The start and duration of the burst access is controlled by \overline{ADSC} , \overline{ADSP} and \overline{ADV} and chip select pins.

The accesses are enabled with the chip select signals and output enabled signals. Wait states are inserted into the access with \overline{ADV} .

When \overline{ZZ} is pulled high, the SRAM will enter a Power Down State. At this time, internal state of the SRAM is preserved. When \overline{ZZ} returns to low, the SRAM normally operates after 2cycles of wake up time. \overline{ZZ} pin is pulled down internally.

Read cycles are initiated with \overline{ADSP} (regardless of \overline{WEx} and \overline{ADSC})using the new external address clocked into the on-chip address register whenever \overline{ADSP} is sampled low, the chip selects are sampled active, and the output buffer is enabled with \overline{OE} . In read operation the data of cell array accessed by the current address, registered in the Data-out registers by the positive edge of \overline{CLK} , are carried to the Data-out buffer by the next positive edge of \overline{CLK} . The data, registered in the Data-out buffer, are projected to the output pins. \overline{ADV} is ignored on the clock edge that samples \overline{ADSP} asserted, but is sampled on the subsequent clock edges. The address increases internally for the next access of the burst when \overline{WEx} are sampled High and \overline{ADV} is sampled low. And \overline{ADSP} is blocked to control signals by disabling $\overline{CS1}$.

All byte write is done by \overline{GW} (regardless of \overline{BW} and \overline{WEx}), and each byte write is performed by the combination of \overline{BW} and \overline{WEx} when \overline{GW} is high.

Write cycles are performed by disabling the output buffers with \overline{OE} and asserting \overline{WEx} . \overline{WEx} are ignored on the clock edge that samples \overline{ADSP} low, but are sampled on the subsequent clock edges. The output buffers are disabled when \overline{WEx} are sampled Low(regardless of \overline{OE}). Data is clocked into the data input register when \overline{WEx} sampled Low. The address increases internally to the next address of burst, if both \overline{WEx} and \overline{ADV} are sampled Low. Individual byte write cycles are performed by any one or more byte write enable signals(\overline{WEa} , \overline{WEb} , \overline{WEc} or \overline{WEd}) sampled low. The \overline{WEa} control $\overline{DQa0} \sim \overline{DQa7}$ and \overline{DQPa} , \overline{WEb} controls $\overline{DQb0} \sim \overline{DQb7}$ and \overline{DQPb} , \overline{WEc} controls $\overline{DQc0} \sim \overline{DQc7}$ and \overline{DQPC} , and \overline{WEd} control $\overline{DQd0} \sim \overline{DQd7}$ and \overline{DQPd} . Read or write cycle may also be initiated with \overline{ADSC} , instead of \overline{ADSP} . The differences between cycles initiated with \overline{ADSC} and \overline{ADSP} as are follows;

\overline{ADSP} must be sampled high when \overline{ADSC} is sampled low to initiate a cycle with \overline{ADSC} .

\overline{WEx} are sampled on the same clock edge that sampled \overline{ADSC} low (and \overline{ADSP} high).

Addresses are generated for the burst access as shown below. The starting point of the burst sequence is provided by the external address. The burst address counter wraps around to its initial state upon completion. The burst sequence is determined by the state of the \overline{LBO} pin. When this pin is Low, linear burst sequence is selected. When this pin is High, Interleaved burst sequence is selected.

BURST SEQUENCE TABLE

(Interleaved Burst)

\overline{LBO} PIN	HIGH	Case 1		Case 2		Case 3		Case 4	
		A1	A0	A1	A0	A1	A0	A1	A0
	First Address	0	0	0	1	1	0	1	0
	↓	0	1	0	0	1	1	1	1
	↓	1	0	1	1	0	0	0	1
	Fourth Address	1	1	1	0	0	1	0	0

(Linear Burst)

\overline{LBO} PIN	LOW	Case 1		Case 2		Case 3		Case 4	
		A1	A0	A1	A0	A1	A0	A1	A0
	First Address	0	0	0	1	1	0	1	1
	↓	0	1	1	0	1	1	0	0
	↓	1	0	1	1	0	0	0	1
	Fourth Address	1	1	0	0	0	1	1	0

Note : 1. \overline{LBO} pin must be tied to High or Low, and Floating State must not be allowed.

ASYNCHRONOUS TRUTH TABLE

Operation	\overline{ZZ}	\overline{OE}	I/O STATUS
Sleep Mode	H	X	High-Z
Read	L	L	DQ
	L	H	High-Z
Write	L	X	Din, High-Z
Deselected	L	X	High-Z

Notes

1. X means "Don't Care".
2. \overline{ZZ} pin is pulled down internally
3. For write cycles that following read cycles, the output buffers must be disabled with \overline{OE} , otherwise data bus contention will occur.
4. Sleep Mode means power down state of which stand-by current does not depend on cycle time.
5. Deselected means power down state of which stand-by current depends on cycle time.

TRUTH TABLES

SYNCHRONOUS TRUTH TABLE

CS ₁	CS ₂	CS ₂	ADSP	ADSC	ADV	WRITE	CLK	ADDRESS ACCESSED	OPERATION
H	X	X	X	L	X	X	↑	N/A	Not Selected
L	L	X	L	X	X	X	↑	N/A	Not Selected
L	X	H	L	X	X	X	↑	N/A	Not Selected
L	L	X	X	L	X	X	↑	N/A	Not Selected
L	X	H	X	L	X	X	↑	N/A	Not Selected
L	H	L	L	X	X	X	↑	External Address	Begin Burst Read Cycle
L	H	L	H	L	X	L	↑	External Address	Begin Burst Write Cycle
L	H	L	H	L	X	H	↑	External Address	Begin Burst Read Cycle
X	X	X	H	H	L	H	↑	Next Address	Continue Burst Read Cycle
H	X	X	X	H	L	H	↑	Next Address	Continue Burst Read Cycle
X	X	X	H	H	L	L	↑	Next Address	Continue Burst Write Cycle
H	X	X	X	H	L	L	↑	Next Address	Continue Burst Write Cycle
X	X	X	H	H	H	H	↑	Current Address	Suspend Burst Read Cycle
H	X	X	X	H	H	H	↑	Current Address	Suspend Burst Read Cycle
X	X	X	H	H	H	L	↑	Current Address	Suspend Burst Write Cycle
H	X	X	X	H	H	L	↑	Current Address	Suspend Burst Write Cycle

- Notes :** 1. X means "Don't Care". 2. The rising edge of clock is symbolized by ↑.
 3. $\overline{\text{WRITE}} = \text{L}$ means Write operation in WRITE TRUTH TABLE.
 $\overline{\text{WRITE}} = \text{H}$ means Read operation in WRITE TRUTH TABLE.
 4. Operation finally depends on status of asynchronous input pins(ZZ and $\overline{\text{OE}}$).

WRITE TRUTH TABLE_(x36)

$\overline{\text{GW}}$	$\overline{\text{BW}}$	$\overline{\text{WEa}}$	$\overline{\text{WEb}}$	$\overline{\text{WEc}}$	$\overline{\text{WEd}}$	OPERATION
H	H	X	X	X	X	READ
H	L	H	H	H	H	READ
H	L	L	H	H	H	WRITE BYTE a
H	L	H	L	H	H	WRITE BYTE b
H	L	H	H	L	L	WRITE BYTE c and d
H	L	L	L	L	L	WRITE ALL BYTES
L	X	X	X	X	X	WRITE ALL BYTES

- Notes :** 1. X means "Don't Care".
 2. All inputs in this table must meet setup and hold time around the rising edge of CLK(↑).

WRITE TRUTH TABLE_(x18)

$\overline{\text{GW}}$	$\overline{\text{BW}}$	$\overline{\text{WEa}}$	$\overline{\text{WEb}}$	OPERATION
H	H	X	X	READ
H	L	H	H	READ
H	L	L	H	WRITE BYTE a
H	L	H	L	WRITE BYTE b
H	L	L	L	WRITE ALL BYTES
L	X	X	X	WRITE ALL BYTES

- Notes :** 1. X means "Don't Care".
 2. All inputs in this table must meet setup and hold time around the rising edge of CLK(↑).

ABSOLUTE MAXIMUM RATINGS*

PARAMETER		SYMBOL	RATING	UNIT
Voltage on V _{DD} Supply Relative to V _{SS}		V _{DD}	-0.3 to 4.6	V
Voltage on V _{DDQ} Supply Relative to V _{SS}		V _{DDQ}	V _{DD}	V
Voltage on Input Pin Relative to V _{SS}		V _{IN}	-0.3 to V _{DD} +0.3	V
Voltage on I/O Pin Relative to V _{SS}		V _{IO}	-0.3 to V _{DDQ} +0.3	V
Power Dissipation		P _D	1.6	W
Storage Temperature		T _{STG}	-65 to 150	°C
Operating Temperature	Commercial	T _{OPR}	0 to 70	°C
	Industrial	T _{OPR}	-40 to 85	°C
Storage Temperature Range Under Bias		T _{BIAS}	-10 to 85	°C

*Note : Stresses greater than those listed under "Absolute Maximum Ratings" may cause permanent damage to the device. This is a stress rating only and functional operation of the device at these or any other conditions above those indicated in the operating sections of this specification is not implied. Exposure to absolute maximum rating conditions for extended periods may affect reliability.

OPERATING CONDITIONS at 3.3V I/O (0°C ≤ T_A ≤ 70°C)

PARAMETER	SYMBOL	MIN	Typ.	MAX	UNIT
Supply Voltage	V _{DD}	3.135	3.3	3.465	V
	V _{DDQ}	3.135	3.3	3.465	V
Ground	V _{SS}	0	0	0	V

OPERATING CONDITIONS at 2.5V I/O (0°C ≤ T_A ≤ 70°C)

PARAMETER	SYMBOL	MIN	Typ.	MAX	UNIT
Supply Voltage	V _{DD}	3.135	3.3	3.465	V
	V _{DDQ}	2.375	2.5	2.9	V
Ground	V _{SS}	0	0	0	V

CAPACITANCE* (T_A=25°C, f=1MHz)

PARAMETER	SYMBOL	TEST CONDITION	MIN	MAX	UNIT
Input Capacitance	C _{IN}	V _{IN} =0V	-	5	pF
Output Capacitance	C _{OUT}	V _{OUT} =0V	-	7	pF

*Note : Sampled not 100% tested.

DC ELECTRICAL CHARACTERISTICS ($V_{DD}=3.3V+0.165V/-0.165V$, $T_A=0^{\circ}C$ to $+70^{\circ}C$)

PARAMETER	SYMBOL	TEST CONDITIONS	MIN	MAX	UNIT	NOTES	
Input Leakage Current(except ZZ)	IIL	$V_{DD} = \text{Max}$; $V_{IN}=V_{SS}$ to V_{DD}	-2	+2	μA		
Output Leakage Current	IOL	Output Disabled, $V_{OUT}=V_{SS}$ to V_{DDQ}	-2	+2	μA		
Operating Current	ICC	Device Selected, $I_{OUT}=0mA$, $ZZ \leq V_{IL}$, Cycle Time $\geq t_{CYC}$ Min	-25	-	460	mA	1,2
			-20	-	410		
			-14	-	310		
Standby Current	ISB	Device deselected, $I_{OUT}=0mA$, $ZZ \leq V_{IL}$, $f = \text{Max}$, All Inputs $\leq 0.2V$ or $\geq V_{DD}-0.2V$	-25	-	170	mA	
			-20	-	150		
			-14	-	140		
	ISB1	Device deselected, $I_{OUT}=0mA$, $ZZ \leq 0.2V$, $f = 0$, All Inputs=fixed ($V_{DD}-0.2V$ or $0.2V$)	-	-	110	mA	
ISB2	Device deselected, $I_{OUT}=0mA$, $ZZ \geq V_{DD}-0.2V$, $f = \text{Max}$, All Inputs $\leq V_{IL}$ or $\geq V_{IH}$	-	-	100	mA		
Output Low Voltage(3.3V I/O)	VOL	$I_{OL}=8.0mA$	-	0.4	V		
Output High Voltage(3.3V I/O)	VOH	$I_{OH}=-4.0mA$	2.4	-	V		
Output Low Voltage(2.5V I/O)	VOL	$I_{OL}=1.0mA$	-	0.4	V		
Output High Voltage(2.5V I/O)	VOH	$I_{OH}=-1.0mA$	2.0	-	V		
Input Low Voltage(3.3V I/O)	VIL		-0.3*	0.8	V		
Input High Voltage(3.3V I/O)	VIH		2.0	$V_{DD}+0.3^{**}$	V	3	
Input Low Voltage(2.5V I/O)	VIL		-0.3*	0.7	V		
Input High Voltage(2.5V I/O)	VIH		1.7	$V_{DD}+0.3^{**}$	V	3	

- Notes** : 1. Reference AC Operating Conditions and Characteristics for input and timing.
2. Data states are all zero.
3. In Case of I/O Pins, the Max. $V_{IH}=V_{DDQ}+0.3V$.

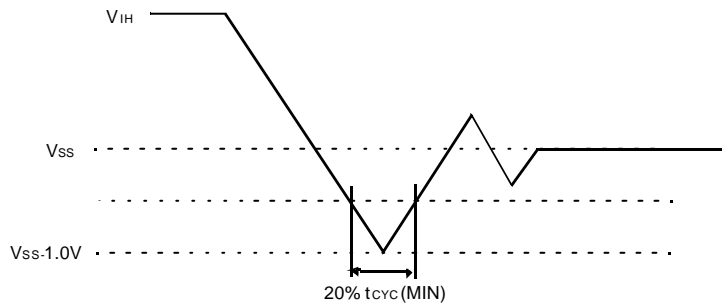

TEST CONDITIONS

($V_{DD}=3.3V+0.165V/-0.165V$, $V_{DDQ}=3.3V+0.165V/-0.165V$ or $V_{DD}=3.3V+0.165V/-0.165V$, $V_{DDQ}=2.5V+0.4V/-0.125V$, $T_A=0$ to $70^{\circ}C$)

PARAMETER	VALUE
Input Pulse Level(for 3.3V I/O)	0 to 3.0V
Input Pulse Level(for 2.5V I/O)	0 to 2.5V
Input Rise and Fall Time(Measured at 20% to 80% for 3.3V I/O)	1.0V/ns
Input Rise and Fall Time(Measured at 20% to 80% for 2.5V I/O)	1.0V/ns
Input and Output Timing Reference Levels for 3.3V I/O	1.5V
Input and Output Timing Reference Levels for 2.5V I/O	$V_{DDQ}/2$
Output Load	See Fig. 1

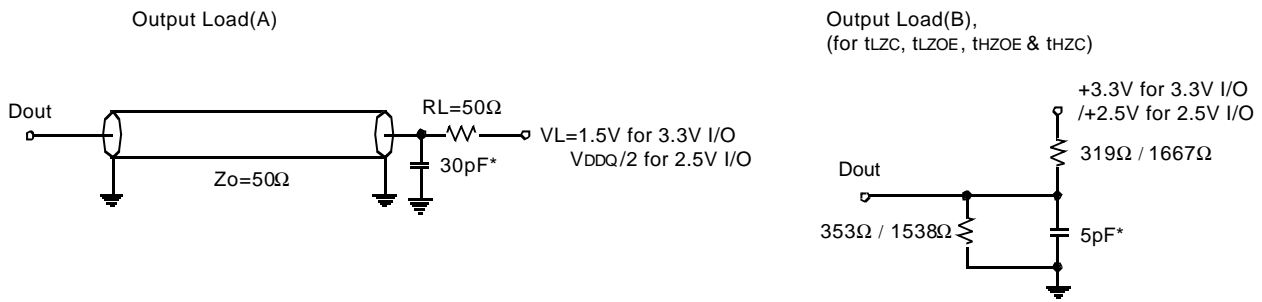

* Including Scope and Jig Capacitance

Fig. 1

AC TIMING CHARACTERISTICS(VDD=3.3V+0.165V/-0.165V, TA=0°C to +70°C)

Parameter	Symbol	-25		-20		-14		Unit
		Min	MAX	MIN	MAX	Min	Max	
Cycle Time	tCYC	4.0	-	5.0	-	7.2	-	ns
Clock Access Time	tCD	-	2.6	-	3.1	-	4.0	ns
Output Enable to Data Valid	tOE	-	2.6	-	3.1	-	4.0	ns
Clock High to Output Low-Z	tLZC	0	-	0	-	0	-	ns
Output Hold from Clock High	tOH	1.5	-	1.5	-	1.5	-	ns
Output Enable Low to Output Low-Z	tLZOE	0	-	0	-	0	-	ns
Output Enable High to Output High-Z	tHZOE	-	2.6	-	3.0	-	3.5	ns
Clock High to Output High-Z	tHZC	1.5	2.6	1.5	3.0	1.5	3.5	ns
Clock High Pulse Width	tCH	1.7	-	2.0	-	2.5	-	ns
Clock Low Pulse Width	tCL	1.7	-	2.0	-	2.5	-	ns
Address Setup to Clock High	tAS	1.2	-	1.4	-	1.5	-	ns
Address Status Setup to Clock High	tSS	1.2	-	1.4	-	1.5	-	ns
Data Setup to Clock High	tDS	1.2	-	1.4	-	1.5	-	ns
Write Setup to Clock High (\overline{GW} , \overline{BW} , \overline{WE})	tWS	1.2	-	1.4	-	1.5	-	ns
Address Advance Setup to Clock High	tADVS	1.2	-	1.4	-	1.5	-	ns
Chip Select Setup to Clock High	tCSS	1.2	-	1.4	-	1.5	-	ns
Address Hold from Clock High	tAH	0.3	-	0.4	-	0.5	-	ns
Address Status Hold from Clock High	tSH	0.3	-	0.4	-	0.5	-	ns
Data Hold from Clock High	tDH	0.3	-	0.4	-	0.5	-	ns
Write Hold from Clock High (\overline{GW} , \overline{BW} ,	tWH	0.3	-	0.4	-	0.5	-	ns
Address Advance Hold from Clock High	tADVH	0.3	-	0.4	-	0.5	-	ns
Chip Select Hold from Clock High	tCSH	0.3	-	0.4	-	0.5	-	ns
ZZ High to Power Down	tPDS	2	-	2	-	2	-	cycle
ZZ Low to Power Up	tPUS	2	-	2	-	2	-	cycle

Notes : 1. All address inputs must meet the specified setup and hold times for all rising clock edges whenever \overline{ADSC} and/or \overline{ADSP} is sampled low and CS is sampled low. All other synchronous inputs must meet the specified setup and hold times whenever this device is chip selected.
2. Both chip selects must be active whenever \overline{ADSC} or \overline{ADSP} is sampled low in order for the this device to remain enabled.
3. \overline{ADSC} or \overline{ADSP} must not be asserted for at least 2 Clock after leaving ZZ state.

TIMING WAVEFORM OF READ CYCLE

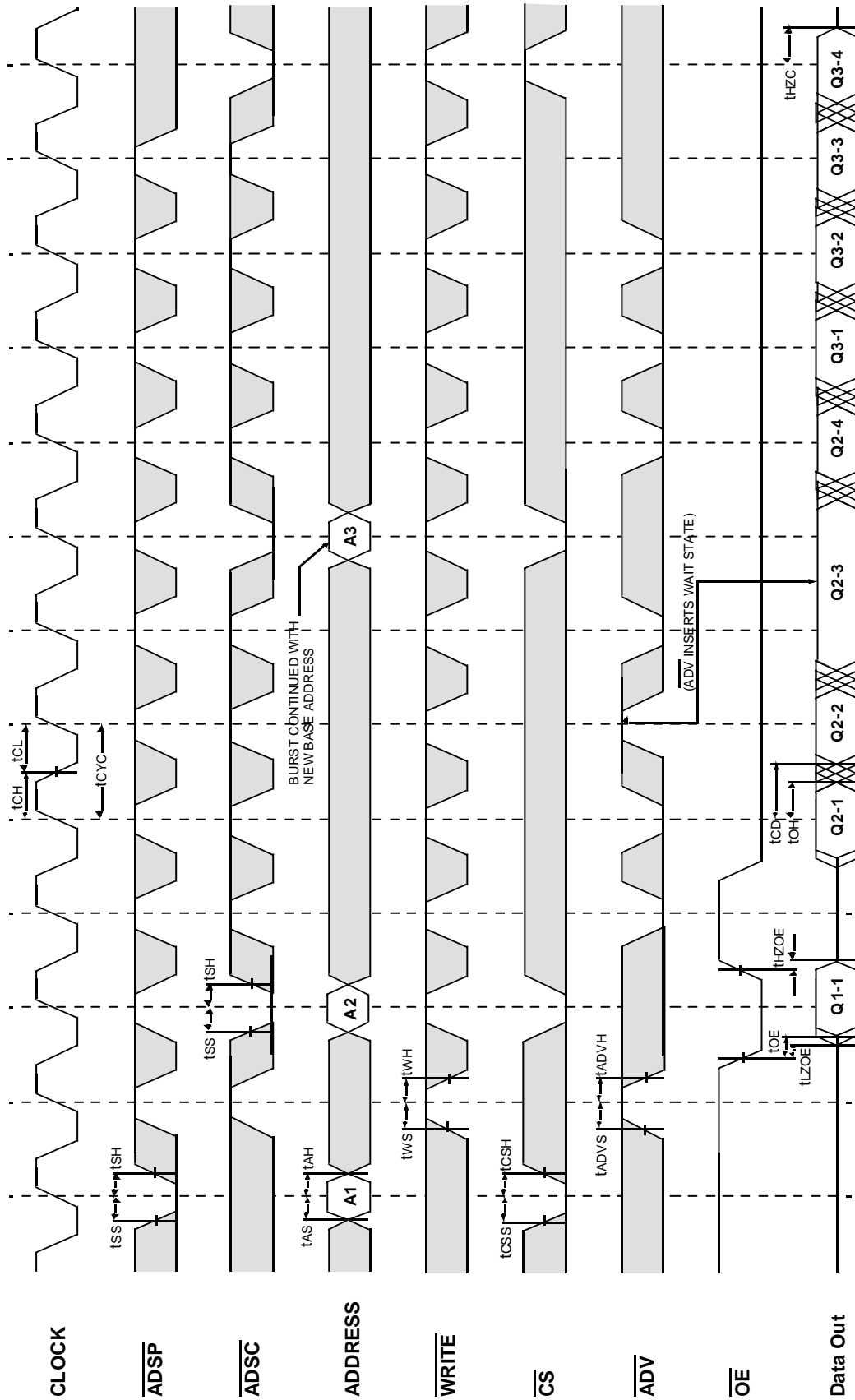

□ Don't Care
▨ Undefined

NOTES : $\overline{WRITE} = L$ means $\overline{GW} = L$, or $\overline{GW} = H, \overline{BW} = L, \overline{WEX} = L$
 $\overline{CS} = L$ means $\overline{CS}_1 = L, \overline{CS}_2 = H$ and $\overline{CS}_2 = L$
 $\overline{CS} = H$ means $\overline{CS}_1 = H$, or $\overline{CS}_1 = L$ and $\overline{CS}_2 = H$, or $\overline{CS}_1 = L$, and $\overline{CS}_2 = L$

TIMING WAVEFORM OF WRTE CYCLE

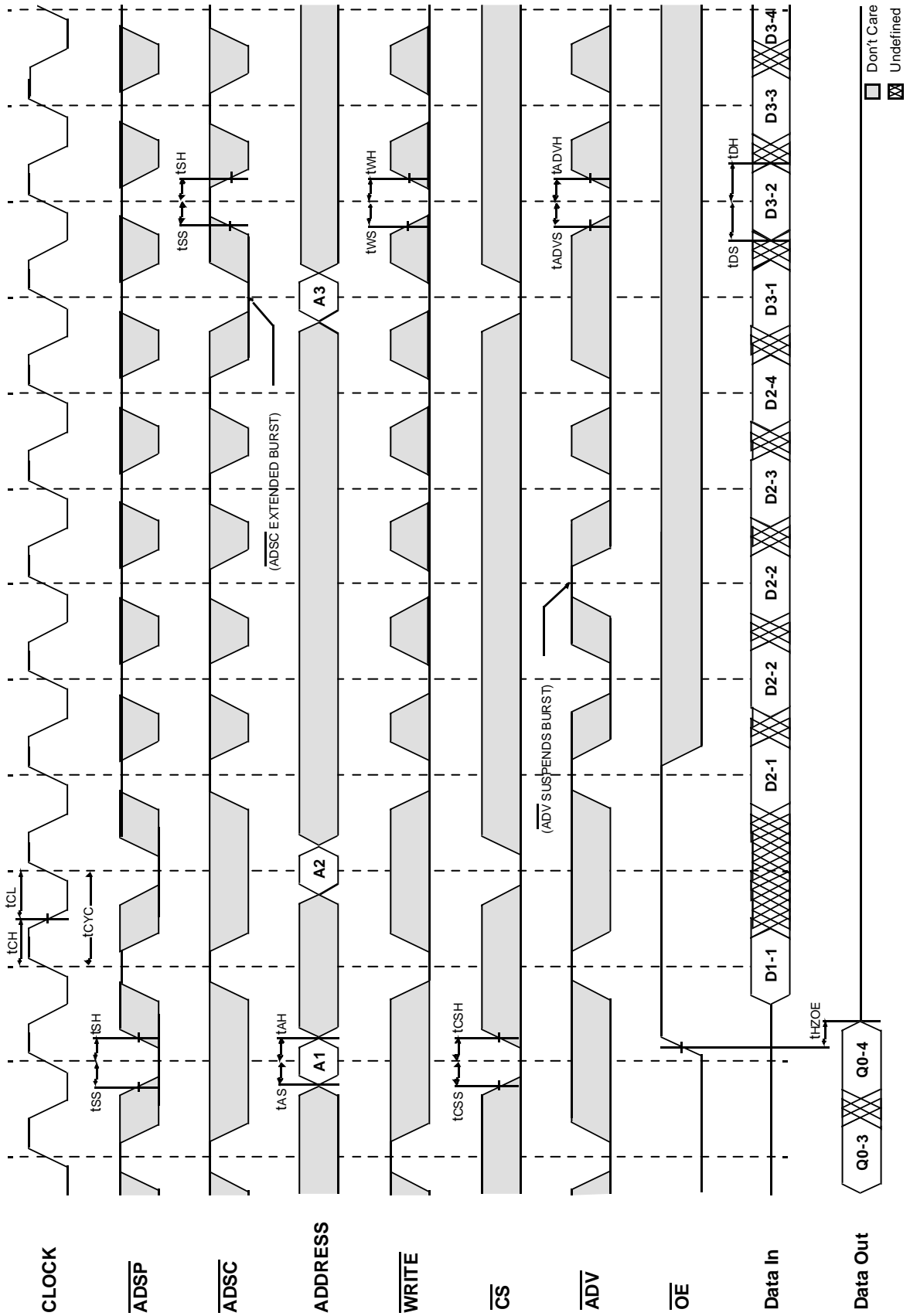

TIMING WAVEFORM OF COMBINATION READ/WRITE CYCLE(ADSP CONTROLLED, $\overline{\text{ADSC}}=\text{HIGH}$)

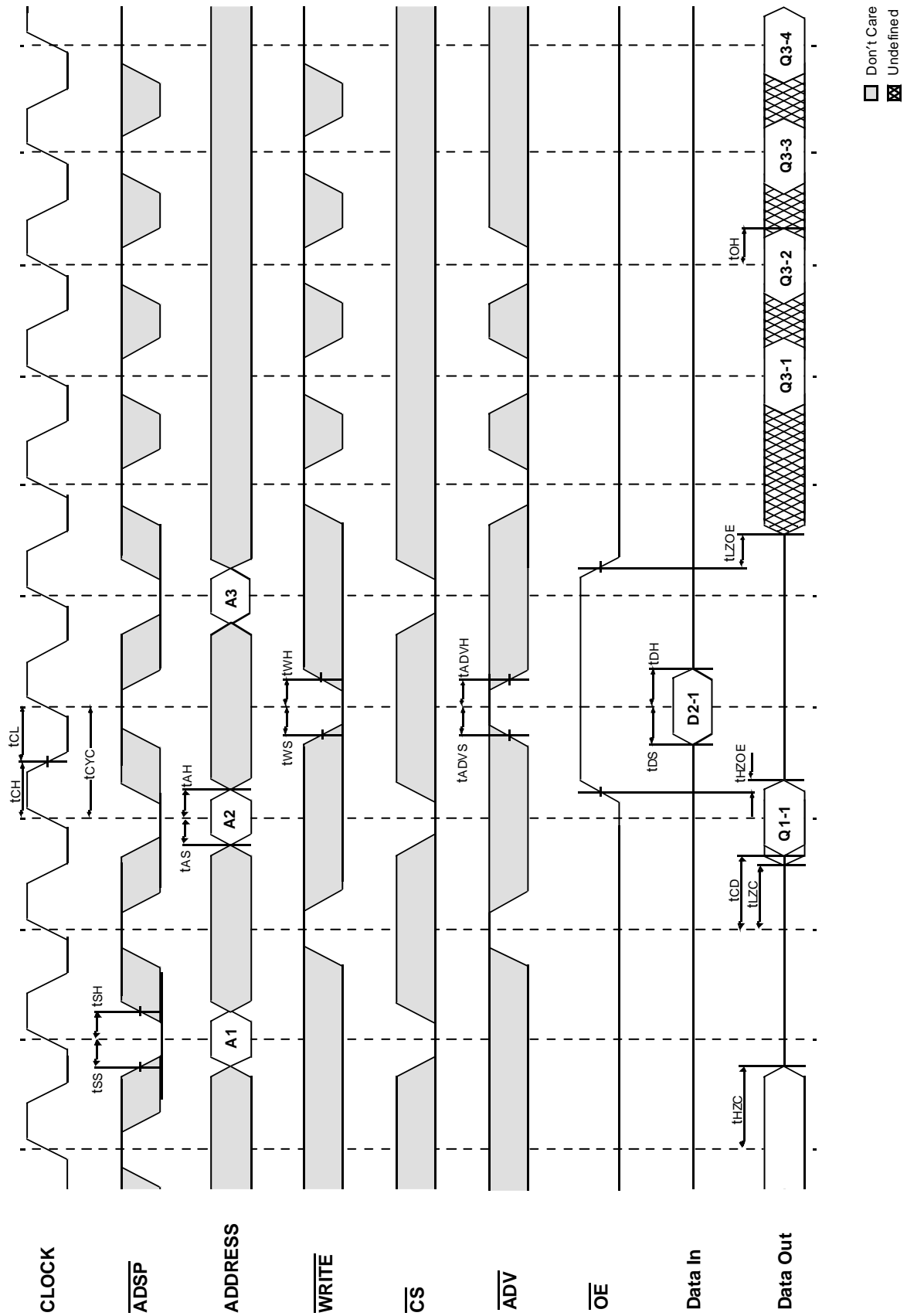

TIMING WAVEFORM OF SINGLE READ/WRITE CYCLE(ADSC CONTROLLED, $\overline{\text{ADSP}}=\text{HIGH}$)

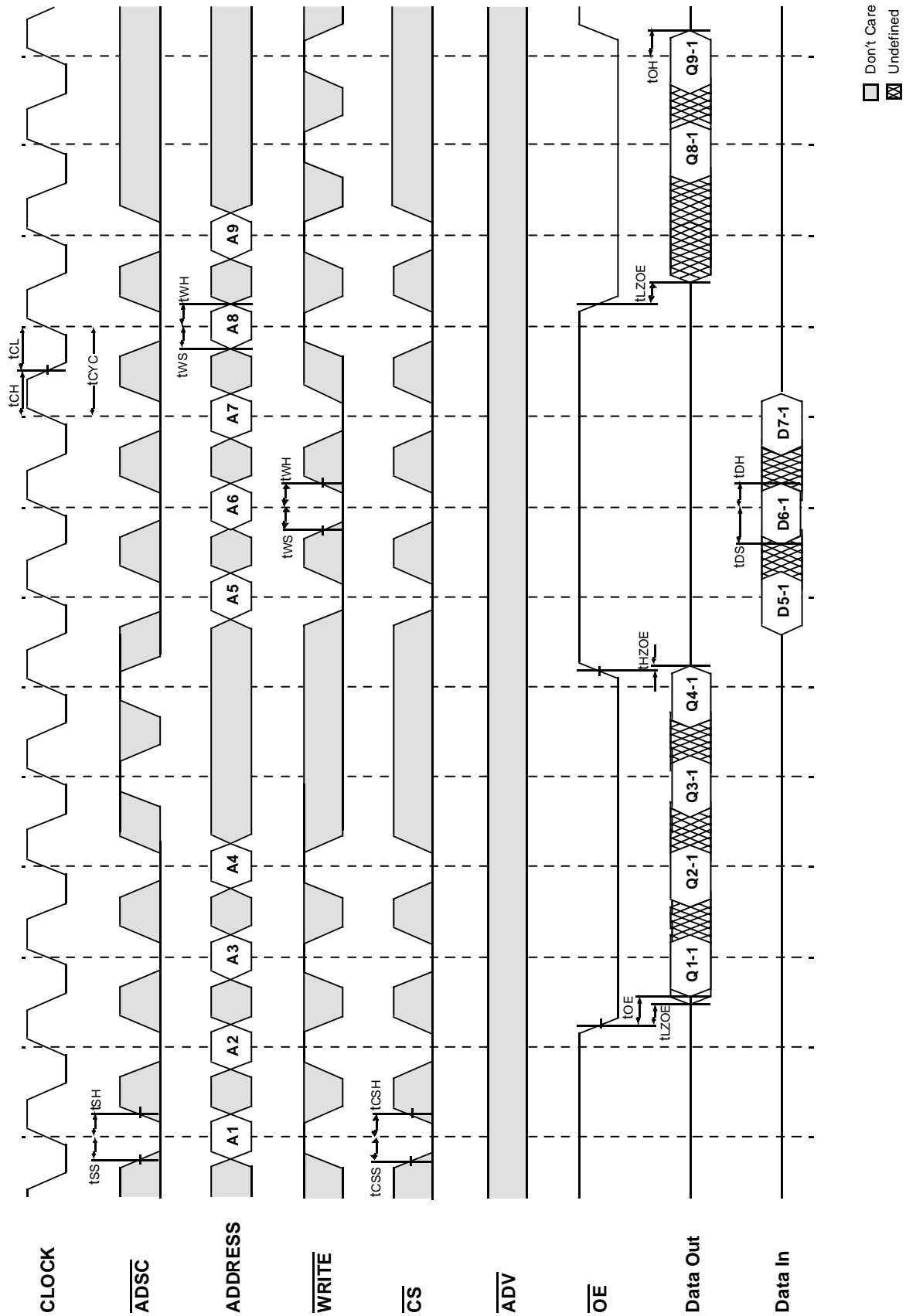

TIMING WAVEFORM OF POWER DOWN CYCLE

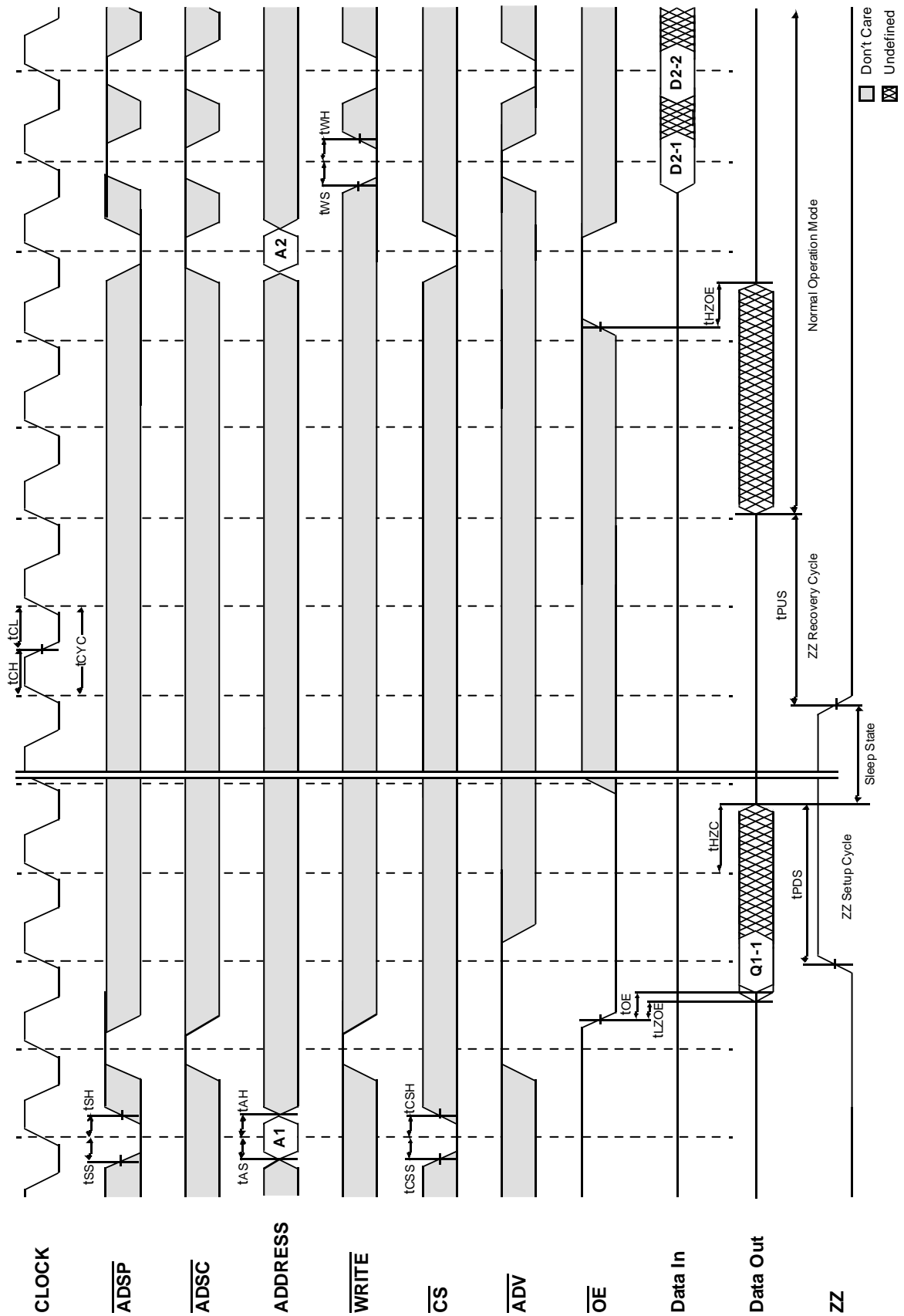

APPLICATION INFORMATION

DEPTH EXPANSION

The Samsung 512Kx36 Synchronous Pipelined Burst SRAM has two additional chip selects for simple depth expansion. This permits easy secondary cache upgrades from 512K depth to 1M depth without extra logic.

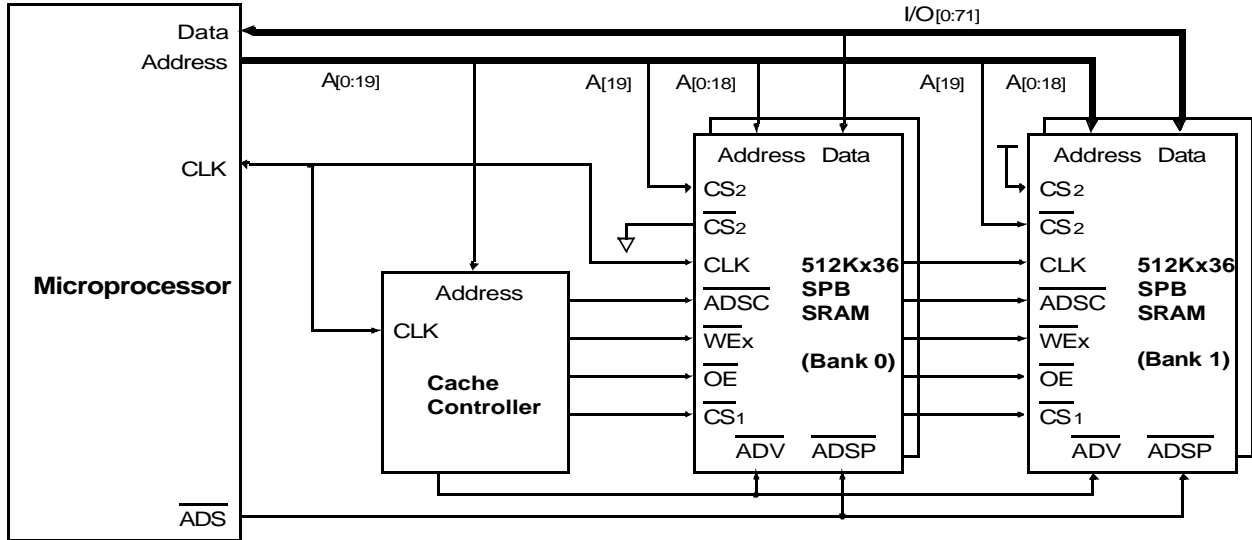

INTERLEAVE READ TIMING (Refer to non-interleave write timing for interleave write timing)

(ADSP CONTROLLED, ADSC=HIGH)

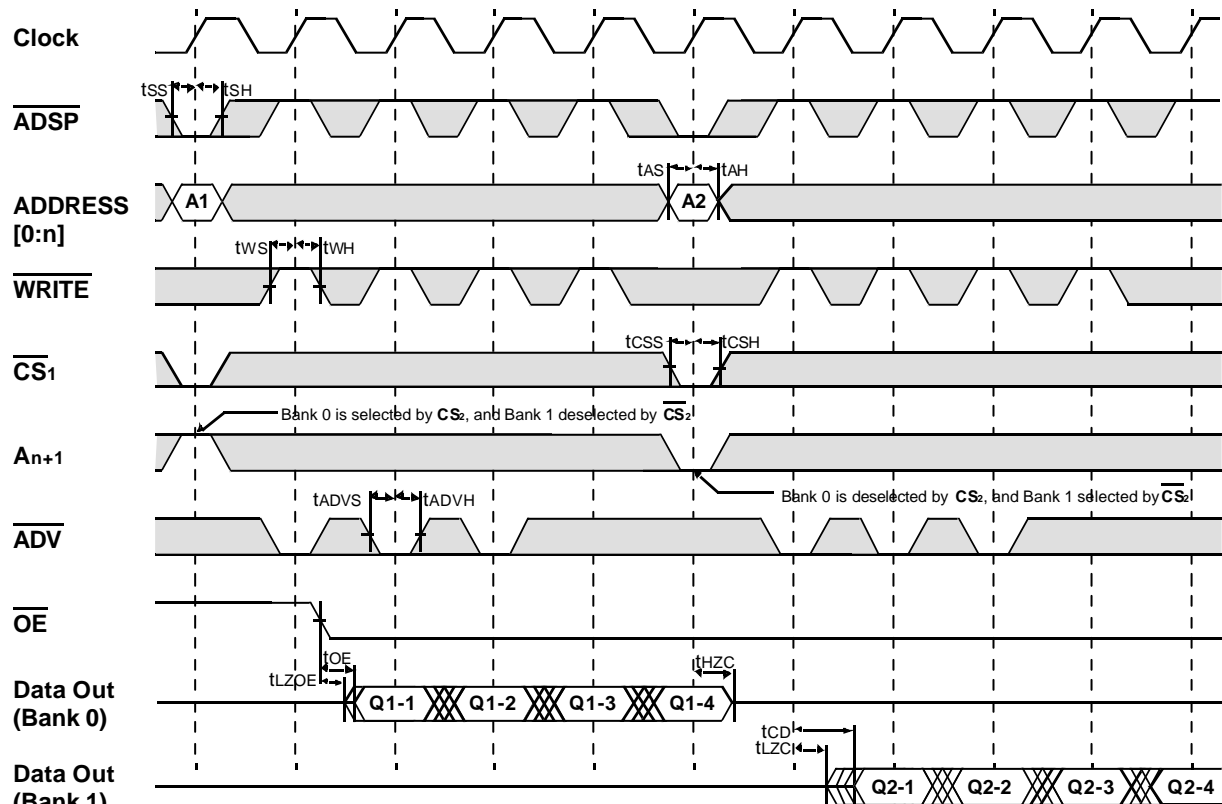

*Notes : n = 14 32K depth , 15 64K depth
16 128K depth , 17 256K depth
18 512K depth , 19 1M depth

□ Don't Care ⊗ Undefined

**APPLICATION INFORMATION
DEPTH EXPANSION**

The Samsung 1Mx18 Synchronous Pipelined Burst SRAM has two additional chip selects for simple depth expansion. This permits easy secondary cache upgrades from 1M depth to 2M depth without extra logic.

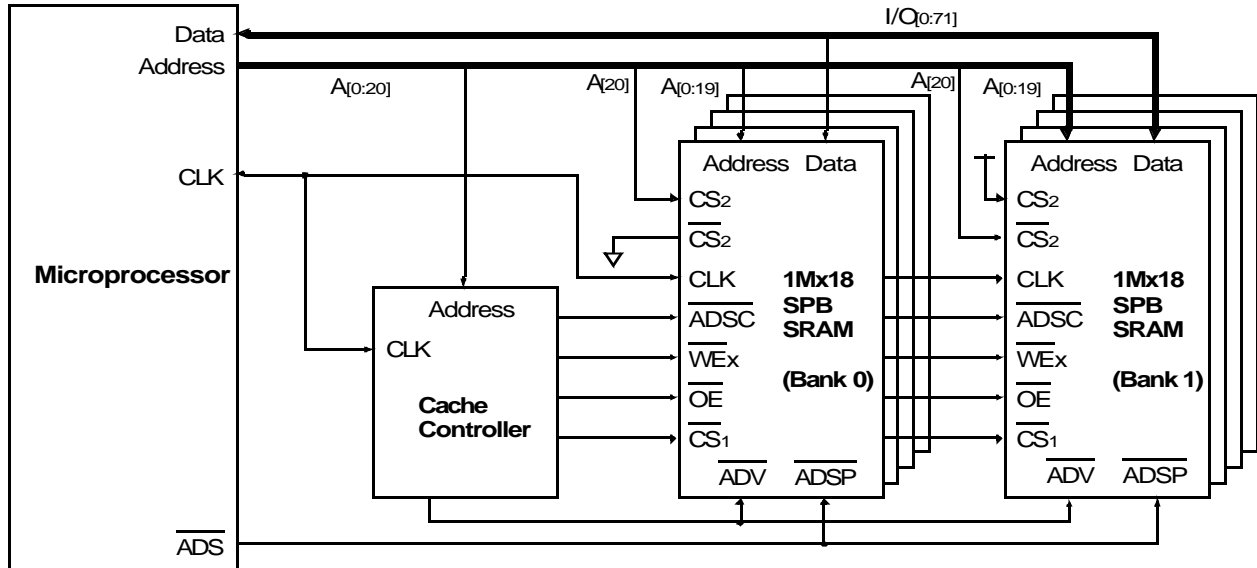

**INTERLEAVE READ TIMING (Refer to non-interleave write timing for interleave write timing)
(ADSP CONTROLLED , ADSC=HIGH)**

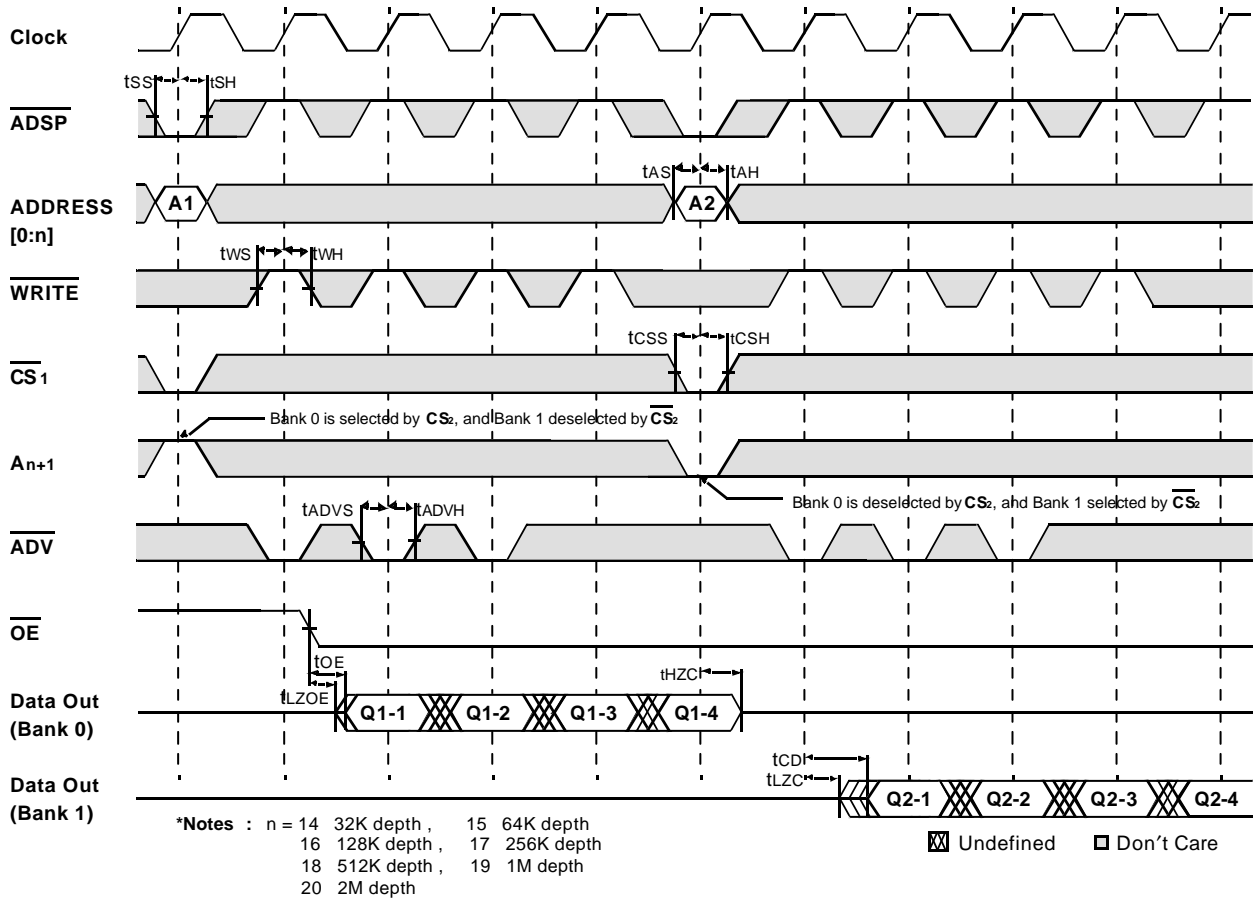

PACKAGE DIMENSIONS

