

PRELIMINARY DATA SHEET

NEC

**NPN SILICON EPITAXIAL
TWIN TRANSISTOR**

UPA837TF

FEATURES

- **SMALL PACKAGE OUTLINE:**
SOT-363 package measures just 2.0 mm x 1.25 mm
- **LOW HEIGHT PROFILE:**
Just 0.60 mm high
- **TWO DIFFERENT DIE TYPES:**
Q1 - Ideal oscillator transistor
Q2 - Ideal buffer amplifier transistor

DESCRIPTION

The UPA837TF contains one NE686 and one NE688 NPN high frequency silicon bipolar chip. NEC's new low profile TF package is ideal for all portable wireless applications where reducing component height is a prime consideration. Each transistor chip is independently mounted and easily configured for oscillator/buffer amplifier and other applications.

OUTLINE DIMENSIONS (Units in mm)

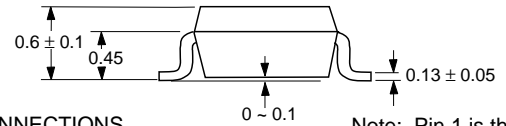
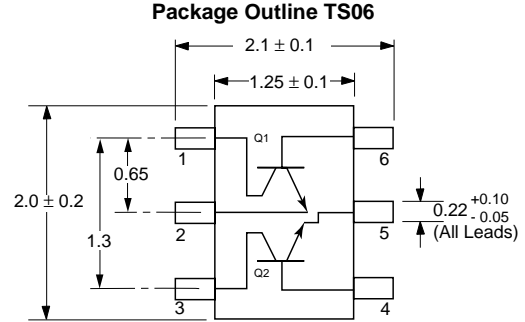

PIN CONNECTIONS

- | | |
|-------------------|-----------------|
| 1. Collector (Q1) | 4. Base (Q2) |
| 2. Emitter (Q1) | 5. Emitter (Q2) |
| 3. Collector (Q2) | 6. Base (Q1) |

Note: Pin 1 is the lower left most pin as the package lettering is oriented and read left to right.

ELECTRICAL CHARACTERISTICS (TA = 25°C)

PART NUMBER PACKAGE OUTLINE				UPA837TF TS06		
	SYMBOLS	PARAMETERS AND CONDITIONS	UNITS	MIN	TYP	MAX
Q1	ICBO	Collector Cutoff Current at VCB = 5 V, IE = 0	μA			0.1
	IEBO	Emitter Cutoff Current at VEB = 1 V, IC = 0	μA			0.1
	hFE	DC Current Gain ¹ at VCE = 2 V, IC = 7 mA		70		140
	f _t	Gain Bandwidth (1) at VCE = 2 V, IC = 7 mA, f = 2 GHz	GHz	10	13	
	f _t	Gain Bandwidth (2) at VCE = 1 V, IC = 5 mA, f = 2 GHz	GHz	8.5	12	
	Cre	Feedback Capacitance ² at VCB = 2 V, IE = 0, f = 1 MHz	pF		0.4	0.6
	S _{21E} ²	Insertion Power Gain (1) at VCE = 2 V, IC = 7 mA, f = 2 GHz	dB	7.5	9	
	S _{21E} ²	Insertion Power Gain (2) at VCE = 1 V, IC = 5 mA, f = 2 GHz	dB	7	8.5	
	NF	Noise Figure (1) at VCE = 2 V, IC = 3 mA, f = 2 GHz	dB		1.5	2
NF	Noise Figure (2) at VCE = 1 V, IC = 3 mA, f = 2 GHz	dB		1.5	2	
Q2	ICBO	Collector Cutoff Current at VCB = 5 V, IE = 0	μA			0.1
	IEBO	Emitter Cutoff Current at VEB = 1 V, IC = 0	μA			0.1
	hFE	DC Current Gain ¹ at VCE = 1 V, IC = 3 mA		100		145
	f _t	Gain Bandwidth (1) at VCE = 1 V, IC = 3 mA, f = 2 GHz	GHz	4.0	4.5	
	f _t	Gain Bandwidth (2) at VCE = 3 V, IC = 20 mA, f = 2 GHz	GHz		9.0	
	Cre	Feedback Capacitance ² at VCB = 1 V, IE = 0, f = 1 MHz	pF		0.75	0.85
	S _{21E} ²	Insertion Power Gain (1) at VCE = 1 V, IC = 3 mA, f = 2 GHz	dB	2.5	3.5	
	S _{21E} ²	Insertion Power Gain (2) at VCE = 3 V, IC = 20 mA, f = 2 GHz	dB		6.5	
	NF	Noise Figure (1) at VCE = 1 V, IC = 3 mA, f = 2 GHz	dB		1.7	2.5
NF	Noise Figure (2) at VCE = 3 V, IC = 7 mA, f = 2 GHz	dB		1.5		

- Notes: 1. Pulsed measurement, pulse width ≤ 350 μs, duty cycle ≤ 2 %.
2. Collector to base capacitance when measured with capacitance meter (automatic balanced bridge method), with emitter connected to guard pin of capacitances meter.

ABSOLUTE MAXIMUM RATINGS¹ ($T_A = 25^\circ\text{C}$)

SYMBOLS	PARAMETERS	UNITS	RATINGS	
			Q1	Q2
V _{CB0}	Collector to Base Voltage	V	5	9
V _{CE0}	Collector to Emitter Voltage	V	3	6
V _{EB0}	Emitter to Base Voltage	V	2	2
I _c	Collector Current	mA	10	100
P _T	Total Power Dissipation	mW	110	110
			200	
T _J	Junction Temperature	°C	150	150
T _{STG}	Storage Temperature	°C	-65 to +150	

Note: 1. Operation in excess of any one of these parameters may result in permanent damage.

ORDERING INFORMATION

PART NUMBER	QUANTITY	PACKAGING
UPA837TF-T1	3000	Tape & Reel

EXCLUSIVE NORTH AMERICAN AGENT FOR **NEC** RF, MICROWAVE & OPTOELECTRONIC SEMICONDUCTORS

CEL CALIFORNIA EASTERN LABORATORIES • Headquarters • 4590 Patrick Henry Drive • Santa Clara, CA 95054-1817 • (408) 988-3500 • Telex 34-6393 • FAX (408) 988-0279
24-Hour Fax-On-Demand: 800-390-3232 (U.S. and Canada only) • Internet: <http://WWW.CEL.COM>

DATA SUBJECT TO CHANGE WITHOUT NOTICE