

HETERO JUNCTION FIELD EFFECT TRANSISTOR
NE33284A

L to X BAND SUPER LOW NOISE AMPLIFIER
 N-CHANNEL HJ-FET

DESCRIPTION

The NE33284A is a Hetero Junction FET that utilizes the hetero junction to create high mobility electrons. Its excellent low noise and high associated gain make it suitable for GPS, TVRO and another commercial systems.

FEATURES

- Super Low Noise Figure & High Associated Gain
 NF = 0.35 dB TYP., $G_a = 15.0$ dB TYP. at $f = 4$ GHz
- Gate Width: $W_g = 280 \mu\text{m}$

ORDERING INFORMATION

PART NUMBER	SUPPLYING FORM	LEAD LENGTH
NE33284A-SL	STICK	L = 1.7 mm MIN.
NE33284A-T1 NE33284A-T1A	Tape & reel	L = 1.0 ±0.2 mm

ABSOLUTE MAXIMUM RATINGS (T_A = 25 °C)

Drain to Source Voltage	V _{DS}	4.0	V
Gate to Source Voltage	V _{GS}	-3.0	V
Drain Current	I _D	I _{DSS}	mA
Total Power Dissipation	P _{tot}	165	mW
Channel Temperature	T _{ch}	150	° C
Storage Temperature	T _{stg}	-65 to +150	° C

RECOMMENDED OPERATING CONDITION (T_A = 25 °C)

CHARACTERISTIC	SYMBOL	MIN.	TYP.	MAX.	Unit
Drain to Source Voltage	V _{bs}		2	3	V
Drain Current	I _D		10	20	mA
Input Power	P _{in}			0	dBm

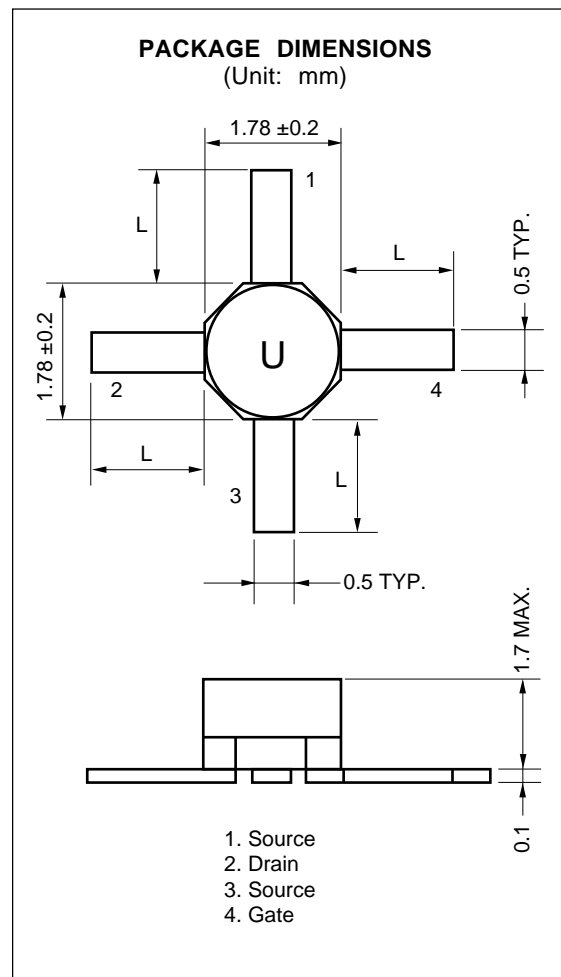

ELECTRICAL CHARACTERISTICS (T_A = 25 °C)

PARAMETER	SYMBOL	MIN.	TYP.	MAX.	UNIT	TEST CONDITIONS	
Gate to Source Leak Current	I _{GSO}		0.5	10	μA	V _{GS} = -3 V	
Saturated Drain Current	I _{DSS}	15	40	80	mA	V _{DS} = 2 V, V _{GS} = 0	
Gate to Source Cutoff Voltage	V _{GS(off)}	-0.2	-0.8	-2.0	V	V _{DS} = 2 V, I _D = 100 μA	
Transconductance	g _m	45	70		mS	V _{DS} = 2 V, I _D = 10 mA	
Noise Figure	NF		0.75	1.0	dB	f = 12 GHz	V _{DS} = 2 V I _D = 10 mA
			0.35	0.45		f = 4 GHz	
Associated Gain	G _a	9.5	10.5		dB	f = 12 GHz	
		13.0	15.0			f = 4 GHz	

PRECAUTION: Avoid high static voltage and electric fields, because this device is Hetero Junction field effect transistor with AlGaAs shottky barrier gate.

TYPICAL CHARACTERISTICS (T_A = 25 °C)

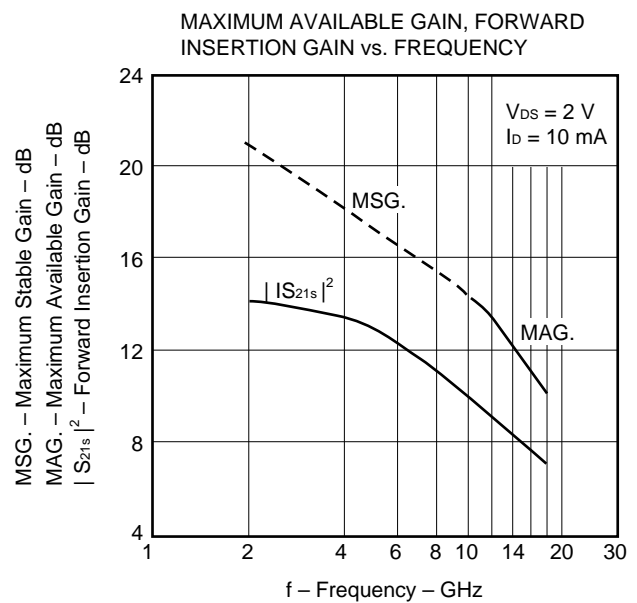
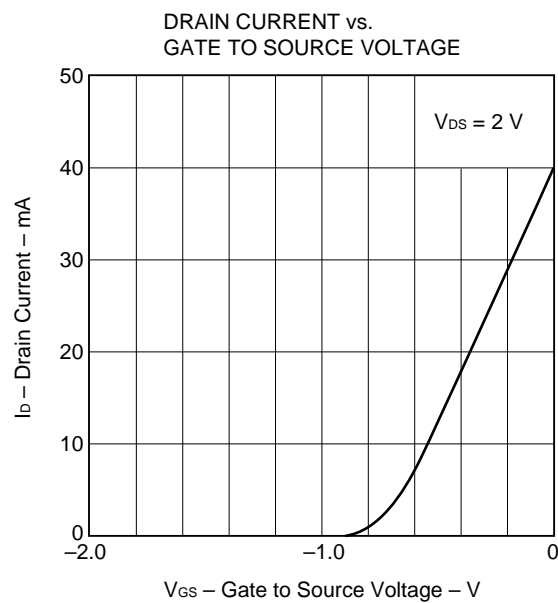
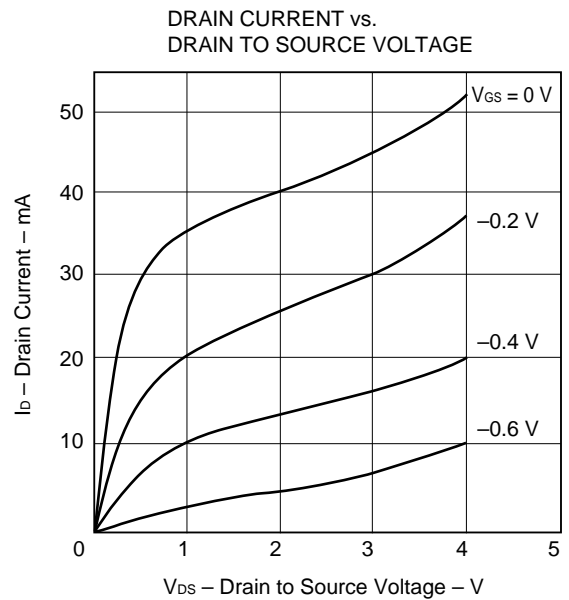
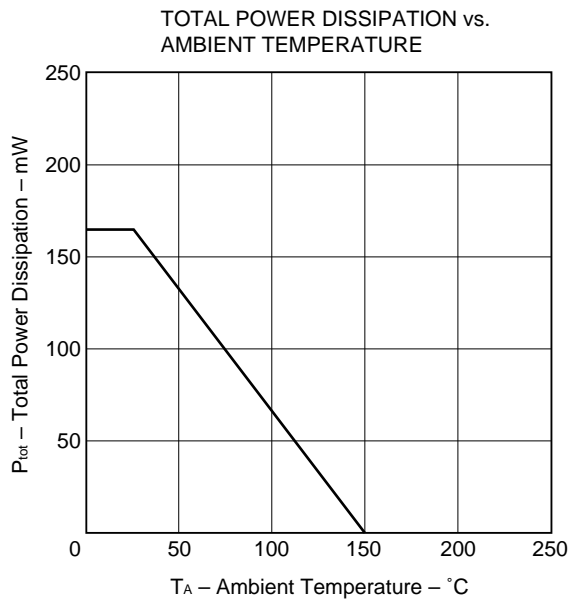

Gain Calculations

$$MSG. = \frac{|S_{21}|}{|S_{12}|} \quad K = \frac{1 + |\Delta|^2 - |S_{11}|^2 - |S_{22}|^2}{2|S_{12}||S_{21}|}$$

$$MAG. = \frac{|S_{21}|}{|S_{12}|} (K \pm \sqrt{K^2 - 1}) \quad \Delta = S_{11} \cdot S_{22} - S_{21} \cdot S_{12}$$

S-Parameters

$V_{DS} = 2\text{ V}$, $I_D = 10\text{ mA}$

START 500 MHz, STOP 18 GHz, STEP 500 MHz

Marker
 1: 4 GHz
 2: 8 GHz
 3: 12 GHz
 4: 16 GHz
 5: 18 GHz

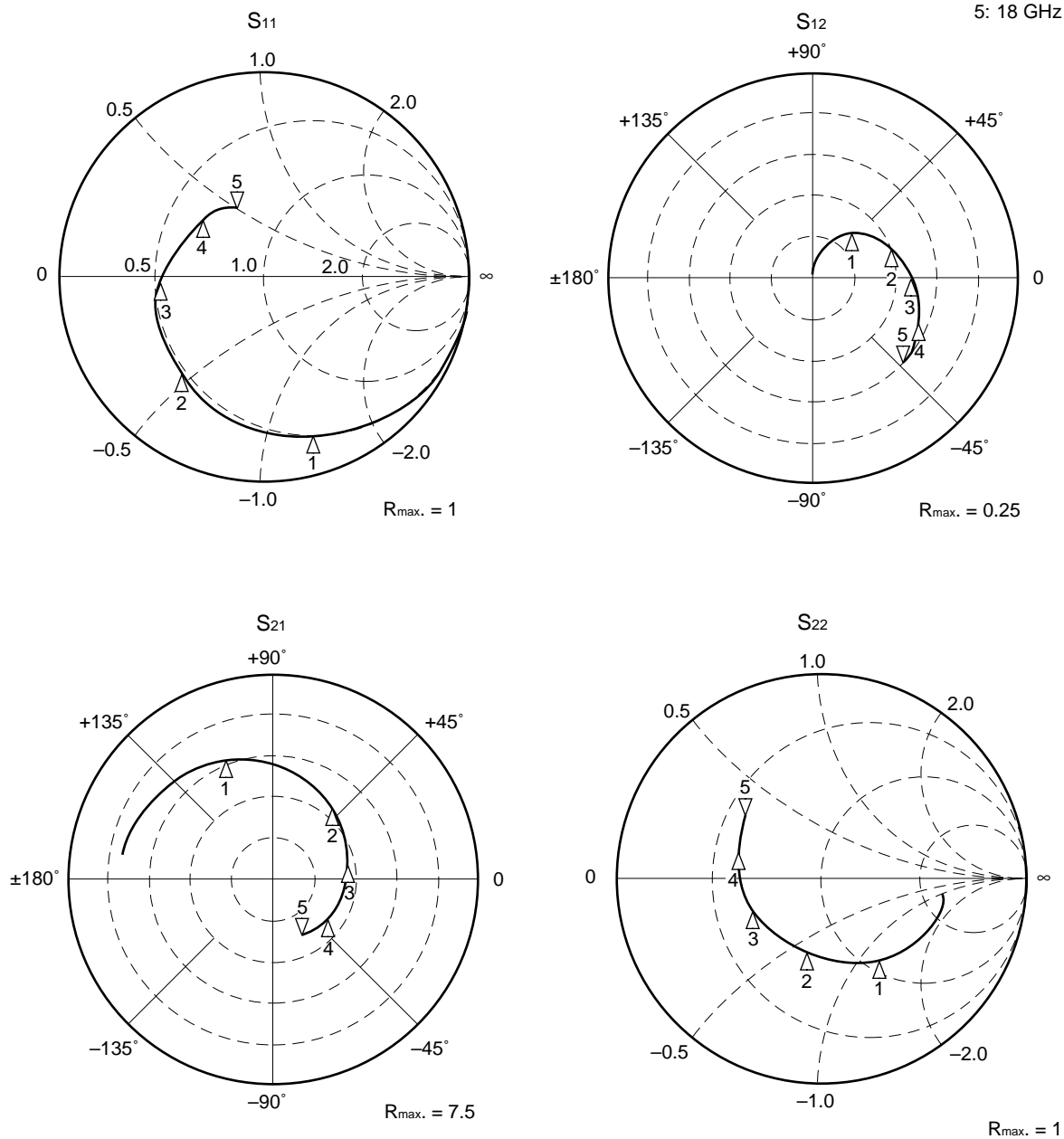

MAG. AND ANG.

$V_{DS} = 2\text{ V}$, $I_D = 10\text{ mA}$

FREQUENCY MHz	S ₁₁		S ₂₁		S ₁₂		S ₂₂	
	MAG.	ANG. (deg.)	MAG.	ANG. (deg.)	MAG.	ANG. (deg.)	MAG.	ANG. (deg.)
500.0000	.916	-9.3	5.239	170.8	.011	83.5	.618	-7.0
1000.0000	.903	-17.2	5.144	162.6	.021	76.8	.609	-13.8
1500.0000	.912	-26.2	5.206	154.0	.032	71.7	.598	-20.5
2000.0000	.903	-34.3	5.147	146.4	.041	66.1	.580	-27.6
2500.0000	.900	-44.2	5.125	136.7	.050	60.3	.563	-34.0
3000.0000	.876	-53.4	5.012	127.3	.059	55.0	.541	-40.4
3500.0000	.845	-62.4	4.862	118.4	.065	49.9	.517	-46.2
4000.0000	.811	-70.6	4.683	110.7	.071	45.6	.493	-52.4
4500.0000	.778	-78.8	4.533	102.7	.076	41.7	.469	-58.6
5000.0000	.754	-86.7	4.378	95.2	.082	37.8	.447	-65.1
5500.0000	.732	-94.8	4.251	87.5	.086	33.7	.425	-71.6
6000.0000	.707	-102.7	4.093	80.0	.091	29.9	.405	-78.3
6500.0000	.681	-109.7	3.933	73.0	.092	26.6	.387	-83.9
7000.0000	.652	-116.3	3.760	66.1	.095	24.2	.372	-89.3
7500.0000	.626	-122.5	3.609	59.7	.098	21.2	.358	-95.0
8000.0000	.599	-128.1	3.480	53.6	.100	18.3	.344	-101.1
8500.0000	.579	-134.0	3.363	47.5	.103	16.3	.333	-107.9
9000.0000	.558	-139.9	3.250	41.7	.105	13.2	.322	-115.2
9500.0000	.542	-146.1	3.151	35.9	.108	10.8	.313	-123.4
10000.0000	.533	-152.1	3.068	30.5	.111	9.1	.311	-130.5
10500.0000	.523	-158.8	3.006	24.8	.114	6.7	.317	-136.6
11000.0000	.511	-164.7	2.942	18.6	.116	3.6	.330	-144.7
11500.0000	.497	-170.2	2.870	12.6	.119	.7	.338	-151.0
12000.0000	.483	-175.7	2.809	7.0	.119	-1.4	.344	-156.5
12500.0000	.466	179.0	2.742	.9	.123	-3.1	.350	-161.0
13000.0000	.444	173.7	2.678	-4.8	.124	-6.2	.356	-166.5
13500.0000	.424	167.8	2.633	-10.4	.129	-9.1	.358	-171.1
14000.0000	.406	162.0	2.562	-16.1	.130	-12.0	.363	-177.3
14500.0000	.397	155.4	2.537	-21.1	.134	-14.4	.375	177.6
15000.0000	.389	148.8	2.502	-26.7	.141	-17.9	.384	170.9
15500.0000	.391	141.2	2.479	-32.3	.140	-21.7	.408	164.3
16000.0000	.392	133.9	2.448	-38.0	.142	-24.6	.421	158.1
16500.0000	.390	127.2	2.426	-44.7	.145	-29.2	.437	153.6
17000.0000	.382	119.9	2.395	-51.3	.145	-32.6	.448	148.2
17500.0000	.367	113.0	2.330	-58.0	.149	-36.6	.462	144.1
18000.0000	.345	106.0	2.273	-64.6	.152	-42.1	.471	139.4

AMP. PARAMETERS

FREQUENCY MHz	GUmax. dB	GAmax. dB	S ₂₁ ² dB	S ₁₂ ² dB	K	Delay nsec	Mason's U dB	G1 dB	G2 dB
500.0000	24.43		14.39	-39.32	.89	.045	24.564	7.96	2.09
1000.0000	23.59		14.23	-33.35	.58	.045	23.761	7.35	2.01
1500.0000	23.98		14.33	-29.82	.38	.048	25.082	7.72	1.93
2000.0000	23.36		14.23	-27.79	.36	.042	25.247	7.35	1.78
2500.0000	23.08		14.19	-26.11	.33	.054	27.129	7.23	1.66
3000.0000	21.84		14.00	-24.62	.38	.053	27.788	6.33	1.50
3500.0000	20.54		13.74	-23.80	.44	.049	27.293	5.45	1.35
4000.0000	19.29		13.41	-22.92	.49	.043	26.733	4.67	1.21
4500.0000	18.25		13.13	-22.38	.54	.044	26.904	4.04	1.08
5000.0000	17.44		12.83	-21.74	.58	.042	28.524	3.65	.97
5500.0000	16.77		12.57	-21.26	.61	.042	31.604	3.33	.86
6000.0000	16.02		12.24	-20.86	.65	.042	35.307	3.00	.78
6500.0000	15.30		11.89	-20.75	.71	.039	30.255	2.70	.70
7000.0000	14.55		11.50	-20.46	.77	.039	29.316	2.40	.65
7500.0000	13.90		11.15	-20.18	.82	.035	26.733	2.16	.59
8000.0000	13.31		10.83	-20.01	.88	.034	24.067	1.93	.55
8500.0000	12.82		10.54	-19.73	.91	.034	24.242	1.77	.51
9000.0000	12.33		10.24	-19.59	.96	.033	22.480	1.62	.48
9500.0000	11.93		9.97	-19.36	.99	.032	22.389	1.51	.45
10000.0000	11.63		9.74	-19.09	.99	.030	23.563	1.45	.44
10500.0000	11.41		9.56	-18.85	.98	.032	25.469	1.39	.46
11000.0000	11.18		9.37	-18.73	.99	.035	26.884	1.31	.50
11500.0000	10.91		9.16	-18.49	1.00	.033	27.948	1.23	.53
12000.0000	10.67	12.82	8.97	-18.47	1.02	.031	25.233	1.16	.55
12500.0000	10.39	12.32	8.76	-18.24	1.04	.034	24.117	1.06	.57
13000.0000	10.10	11.73	8.56	-18.11	1.07	.032	21.495	.96	.59
13500.0000	9.87	11.41	8.41	-17.79	1.08	.031	20.813	.86	.60
14000.0000	9.57	10.92	8.17	-17.71	1.11	.032	18.944	.78	.61
14500.0000	9.49	10.95	8.09	-17.48	1.09	.028	19.425	.74	.66
15000.0000	9.37	11.06	7.96	-17.04	1.06	.031	20.693	.71	.69
15500.0000	9.40	11.35	7.89	-17.11	1.03	.031	21.818	.72	.79
16000.0000	9.35	11.77	7.78	-16.94	1.01	.032	23.233	.73	.85
16500.0000	9.34		7.70	-16.77	.98	.037	26.251	.72	.92
17000.0000	9.25		7.59	-16.77	.99	.036	22.793	.69	.98
17500.0000	9.01		7.35	-16.53	.99	.037	20.955	.63	1.04
18000.0000	8.77	11.32	7.13	-16.37	1.00	.037	19.097	.55	1.09

Noise Parameters

<TYPICAL CONSTANT NOISE FIGURE CIRCLE>

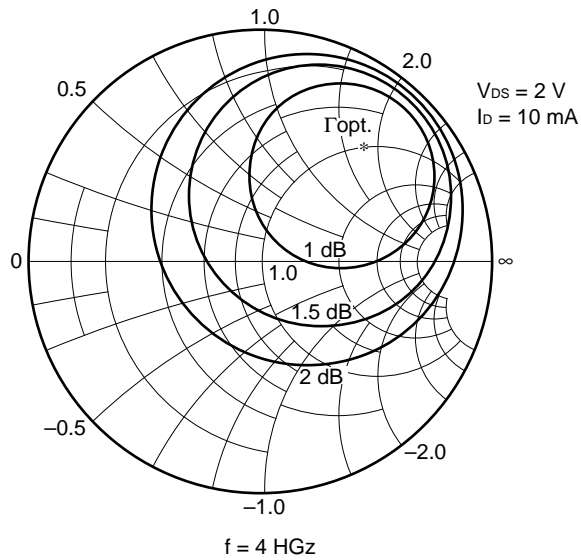

< Γ_{opt} vs. frequency>

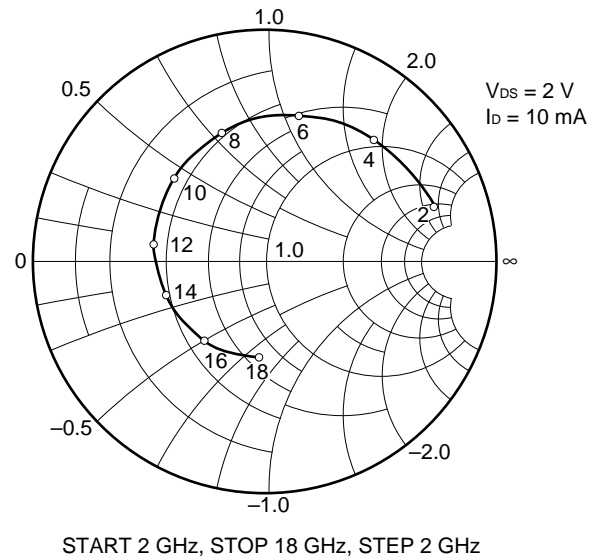

<Noise Parameters>

$V_{DS} = 2\text{ V}, I_D = 10\text{ mA}$

Freq (GHz)	NF_{min} (dB)	G_a (dB)	Γ_{opt} .		$R_n/50$
			Mag.	Ang. (deg.)	
2.0	0.32	16.0	0.76	18	0.23
4.0	0.35	15.0	0.69	49	0.19
6.0	0.41	13.7	0.63	79	0.14
8.0	0.50	12.6	0.58	110	0.08
10.0	0.62	11.5	0.53	140	0.05
12.0	0.75	10.5	0.49	171	0.03
14.0	0.88	9.6	0.46	-158	0.07
16.0	1.02	8.8	0.43	-127	0.09
18.0	1.15	8.0	0.41	-97	0.16

RECOMMENDED SOLDERING CONDITIONS

The following conditions (see table below) must be met when soldering this product.

Please consult with our sales offices in case other soldering process is used, or in case soldering is done under different conditions.

<TYPES OF SURFACE MOUNT DEVICE>

For more details, refer to our document “SEMICONDUCTOR DEVICE MOUNTING TECHNOLOGY MANUAL” (IEI-1207)

[NE33284A]

Soldering process	Soldering conditions	Symbol
Infrared ray reflow	Peak package’s surface temperature: 230 °C or below, Reflow time: 30 seconds or below (210 °C or higher), Number of reflow process: 1, Exposure limit*: None	IR30-00
Partial heating method	Terminal temperature: 230 °C or below, Flow time: 10 seconds or below, Exposure limit*: None	

*: Exposure limit before soldering after dry-pack package is opened.

Storage conditions: 25 °C and relative humidity at 65 % or less.

Note: Do not apply more than a single process at once, except for “Partial heating method”.

PRECAUTION: Avoid high static voltage and electric fields, because this device is Hetero Junction field effect transistor with shottky barrier gate.

Caution

The Great Care must be taken in dealing with the devices in this guide.

The reason is that the material of the devices is GaAs (Gallium Arsenide), which is designated as harmful substance according to the law concerned.

Keep the Japanese law concerned and so on, especially in case of removal.

[MEMO]

No part of this document may be copied or reproduced in any form or by any means without the prior written consent of NEC Corporation. NEC Corporation assumes no responsibility for any errors which may appear in this document.

NEC Corporation does not assume any liability for infringement of patents, copyrights or other intellectual property rights of third parties by or arising from use of a device described herein or any other liability arising from use of such device. No license, either express, implied or otherwise, is granted under any patents, copyrights or other intellectual property rights of NEC Corporation or others.

While NEC Corporation has been making continuous effort to enhance the reliability of its semiconductor devices, the possibility of defects cannot be eliminated entirely. To minimize risks of damage or injury to persons or property arising from a defect in an NEC semiconductor device, customer must incorporate sufficient safety measures in its design, such as redundancy, fire-containment, and anti-failure features.

NEC devices are classified into the following three quality grades:

"Standard", "Special", and "Specific". The Specific quality grade applies only to devices developed based on a customer designated "quality assurance program" for a specific application. The recommended applications of a device depend on its quality grade, as indicated below. Customers must check the quality grade of each device before using it in a particular application.

Standard: Computers, office equipment, communications equipment, test and measurement equipment, audio and visual equipment, home electronic appliances, machine tools, personal electronic equipment and industrial robots

Special: Transportation equipment (automobiles, trains, ships, etc.), traffic control systems, anti-disaster systems, anti-crime systems, safety equipment and medical equipment (not specifically designed for life support)

Specific: Aircrafts, aerospace equipment, submersible repeaters, nuclear reactor control systems, life support systems or medical equipment for life support, etc.

The quality grade of NEC devices in "Standard" unless otherwise specified in NEC's Data Sheets or Data Books. If customers intend to use NEC devices for applications other than those specified for Standard quality grade, they should contact NEC Sales Representative in advance.

Anti-radioactive design is not implemented in this product.