MR27V402D

262,144-Word x 16-Bit or 524,288-Word x 8-Bit One Time PROM

DESCRIPTION

The MR27V402D is a 4Mbit electrically Programmable Read-Only Memory whose configuration can be electrically switched between 262,144 word x 16bit and 524,288 word x 8bit. The MR27V402D operates on a single +3V-3.3V power supply and is TTL compatible. Since the MR27V402D operates asynchronously, external clocks are not required, making this device easy-to-use. The MR27V402D is suitable as large-capacity fixed memory for microcomputers and data terminals. It is manufactured using a CMOS double silicon gate technology and is offered in 40-pin DIP, 40-pin SOP or 44-pin TSOP packages.

FEATURES

- 262,144 word x 16bit / 524,288 word x 8bit electrically switchable configuration
- Single +3V-3.3V power supply
- Access time
 - 90ns access time (Vcc=+3V)
 - 70ns access time (Vcc=+3.3V)
- Input / Output TTL compatible
- Three-state output
- Packages
 - 40-pin plastic DIP (DIP40-P-600-2.54)
 - 40-pin plastic SOP (SOP40-P-525-1.27-K)
 - 44-pin plastic TSOP (TSOP II 44-P-400-0.80-K)

PIN CONFIGURATION (TOP VIEW)

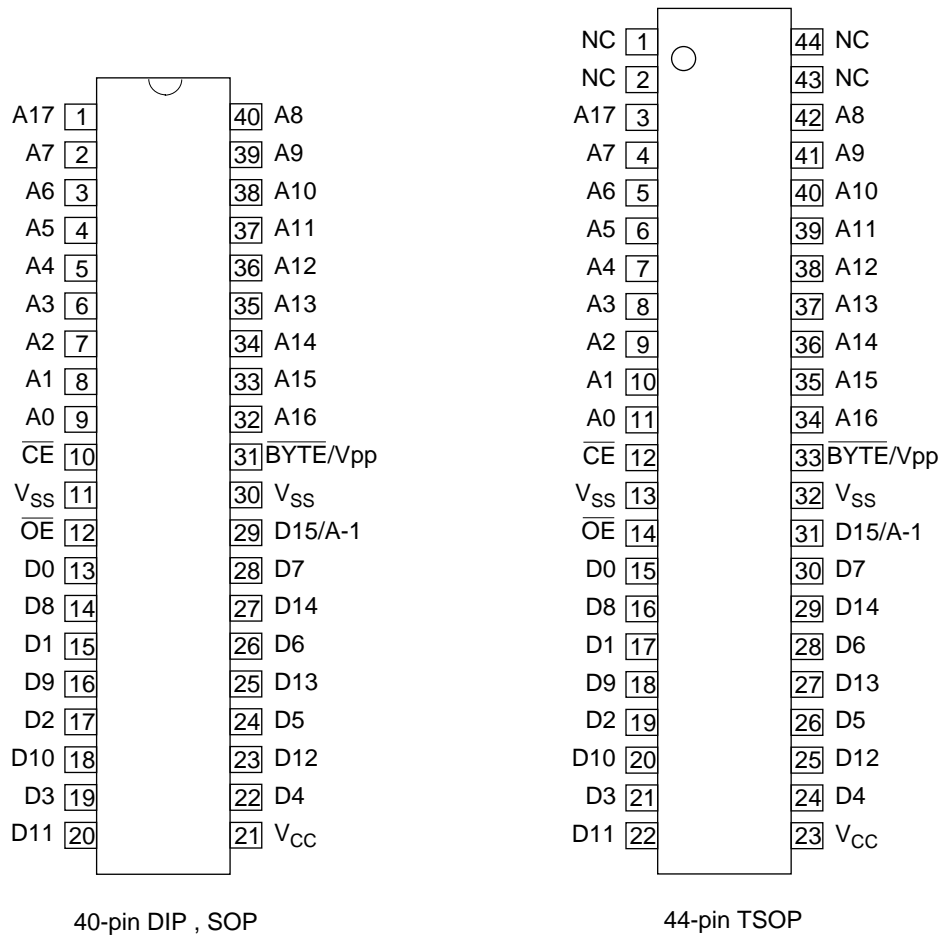

PIN NAMES	FUNCTIONS
D15/A-1	Data output / Address input
A0-A17	Address input
D0-D14	Data output
\overline{CE}	Chip enable
\overline{OE}	Output enable
V_{CC}	Power supply voltage
V_{SS}	GND
\overline{BYTE}/V_{PP}	Mode switch / Program power supply voltage
NC	Non connection

BLOCK DIAGRAM

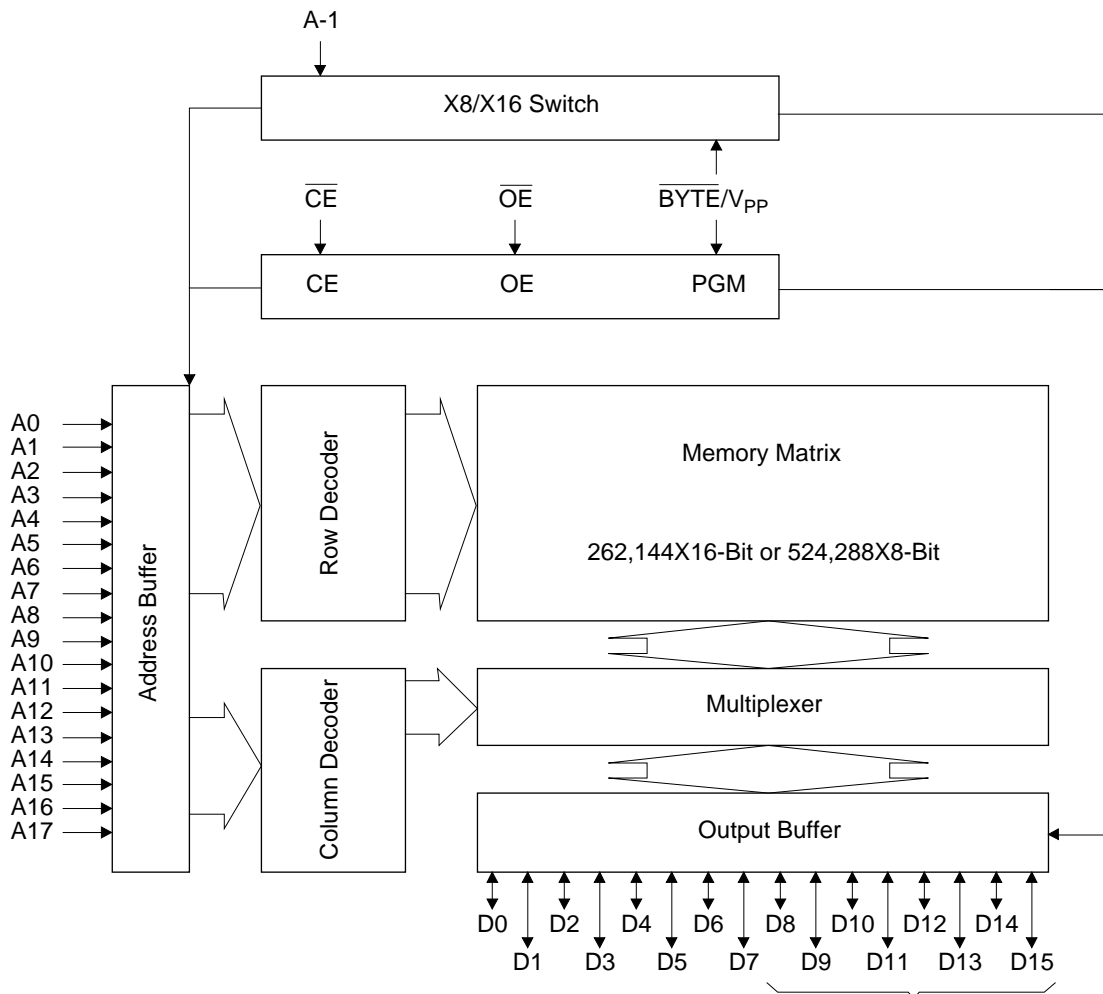

In 8-bit output mode, these pins are three-stated and pin D15 functions as the A-1 address pin.

FUNCTION TABLE

MODE	\overline{CE}	\overline{OE}	BYTE/ V_{PP}	V_{CC}	D0 - D7	D8 - D14	D15/A-1
READ (16-Bit)	L	L	H	3.0V to 3.3V	D_{OUT}		
READ (8-Bit)	L	L	L		D_{OUT}	Hi-Z	L/H
OUTPUT DISABLE	L	H	H		Hi-Z		*
			L		Hi-Z		*
STAND-BY	H	*	H	Hi-Z		*	
			L	Hi-Z		*	
PROGRAM	L	H	9.75V	D_{IN}			
PROGRAM INHIBIT	H	H		Hi-Z			
PROGRAM VERIFY	H	L		D_{OUT}			

*: Don't Care

ABSOLUTE MAXIMUM RATINGS

Parameter	Symbol	Condition	Value	Unit
Operating temperature under bias	T_{opr}	-	0 to 70	°C
Storage temperature	T_{stg}		-55 to 125	°C
Input voltage	V_I	relative to V_{SS}	-0.5 to $V_{CC} + 0.5$	V
Output voltage	V_O		-0.5 to $V_{CC} + 0.5$	V
Power supply voltage	V_{CC}		-0.5 to 5	V
Program power supply voltage	V_{PP}		-0.5 to 11.5	V
Power dissipation per package	P_D	-	1.0	W

RECOMMENDED OPERATING CONDITIONS

(Ta=0 to 70°C)

Parameter	Symbol	Condition	Min.	Typ.	Max.	Unit
V_{CC} power supply voltage	V_{CC}	$V_{CC}=2.7V-3.6V$	2.7	-	3.6	V
V_{PP} power supply voltage	V_{PP}		-0.5	-	$V_{CC}+0.5$	V
Input "H" level	V_{IH}		2.2	-	$V_{CC}+0.5$	V
Input "L" level	V_{IL}		-0.5	-	0.6	V

Voltage is relative to V_{SS}

ELECTRICAL CHARACTERISTICS (Read operation)**DC Characteristics 1** $(V_{CC}=3V\pm 0.3V, T_a=0 \text{ to } 70^\circ\text{C})$

Parameter	Symbol	Condition	Min.	Typ.	Max.	Unit
Input leakage current	I_{LI}	$V_I=0 \text{ to } V_{CC}$	-	-	10	μA
Output leakage current	I_{LO}	$V_O=0 \text{ to } V_{CC}$	-	-	10	μA
V_{CC} power supply current (Standby)	I_{CCSC}	$\overline{CE}=V_{CC}$	-	-	50	μA
	I_{CCST}	$\overline{CE}=V_{IH}$	-	-	1	mA
V_{CC} power supply current (Read)	I_{CCA}	$\overline{CE}=V_{IL}, \overline{OE}=V_{IH} \text{ } t_c=90\text{ns}$	-	-	25	mA
V_{PP} power supply current	I_{PP}	$V_{PP}=V_{CC}$	-	-	10	μA
Input "H" level	V_{IH}	-	2.2	-	$V_{CC}+0.5$	V
Input "L" level	V_{IL}	-	-0.5	-	0.6	V
Output "H" level	V_{OH2}	$I_{OH}=-200\mu\text{A}$	$V_{CC}-0.4$	-	-	V
Output "L" level	V_{OL2}	$I_{OL}=1\text{mA}$	-	-	0.4	V

Voltage is relative to Vss

DC Characteristics 2 $(V_{CC}=3.3V\pm 0.3V, T_a=0 \text{ to } 70^\circ\text{C})$

Parameter	Symbol	Condition	Min.	Typ.	Max.	Unit
Input leakage current	I_{LI}	$V_I=0 \text{ to } V_{CC}$	-	-	10	μA
Output leakage current	I_{LO}	$V_O=0 \text{ to } V_{CC}$	-	-	10	μA
V_{CC} power supply current (Standby)	I_{CCSC}	$\overline{CE}=V_{CC}$	-	-	50	μA
	I_{CCST}	$\overline{CE}=V_{IH}$	-	-	1	mA
V_{CC} power supply current (Read)	I_{CCA}	$\overline{CE}=V_{IL}, \overline{OE}=V_{IH} \text{ } t_c=70\text{ns}$	-	-	30	mA
V_{PP} power supply current	I_{PP}	$V_{PP}=V_{CC}$	-	-	10	μA
Input "H" level	V_{IH}	-	2.2	-	$V_{CC}+0.5$	V
Input "L" level	V_{IL}	-	-0.5	-	0.6	V
Output "H" level	V_{OH2}	$I_{OH}=-200\mu\text{A}$	$V_{CC}-0.4$	-	-	V
Output "L" level	V_{OL2}	$I_{OL}=1\text{mA}$	-	-	0.4	V

Voltage is relative to Vss

AC Characteristics 1(V_{CC}=3V±0.3V, Ta=0 to 70°C)

Parameter	Symbol	Condition	Min.	Max.	Unit
Address cycle time	T _C	-	90	-	ns
Address access time	T _{ACC}	$\overline{CE}=\overline{OE}=V_{IL}$	-	90	ns
\overline{CE} access time	T _{CE}	$\overline{OE}=V_{IL}$	-	90	ns
\overline{OE} access time	T _{OE}	$\overline{CE}=V_{IL}$	-	30	ns
Output disable time	T _{CHZ}	$\overline{OE}=V_{IL}$	0	30	ns
	T _{OHZ}	$\overline{CE}=V_{IL}$	0	20	ns
Output hold time	T _{OH}	$\overline{CE}=\overline{OE}=V_{IL}$	0	-	ns

Measurement conditions

Input signal level	-----	0V/3V
Input timing reference level	-----	0.8V/2.0V
Output load	-----	50pF
Output timing reference level	-----	0.8V/2.0V

AC Characteristics 2(V_{CC}=3.3V±0.3V, Ta=0 to 70°C)

Parameter	Symbol	Condition	Min.	Max.	Unit
Address cycle time	T _C	-	70	-	ns
Address access time	T _{ACC}	$\overline{CE}=\overline{OE}=V_{IL}$	-	70	ns
\overline{CE} access time	T _{CE}	$\overline{OE}=V_{IL}$	-	70	ns
\overline{OE} access time	T _{OE}	$\overline{CE}=V_{IL}$	-	30	ns
Output disable time	T _{CHZ}	$\overline{OE}=V_{IL}$	0	30	ns
	T _{OHZ}	$\overline{CE}=V_{IL}$	0	20	ns
Output hold time	T _{OH}	$\overline{CE}=\overline{OE}=V_{IL}$	0	-	ns

Measurement conditions

Input signal level	-----	0V/3V
Input timing reference level	-----	0.8V/2.0V
Output load	-----	50pF
Output timing reference level	-----	0.8V/2.0V

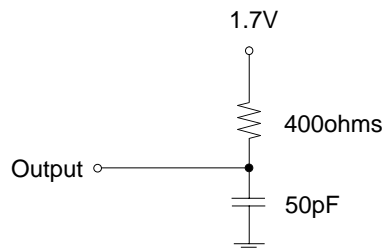

TIMING CHART (READ CYCLE)

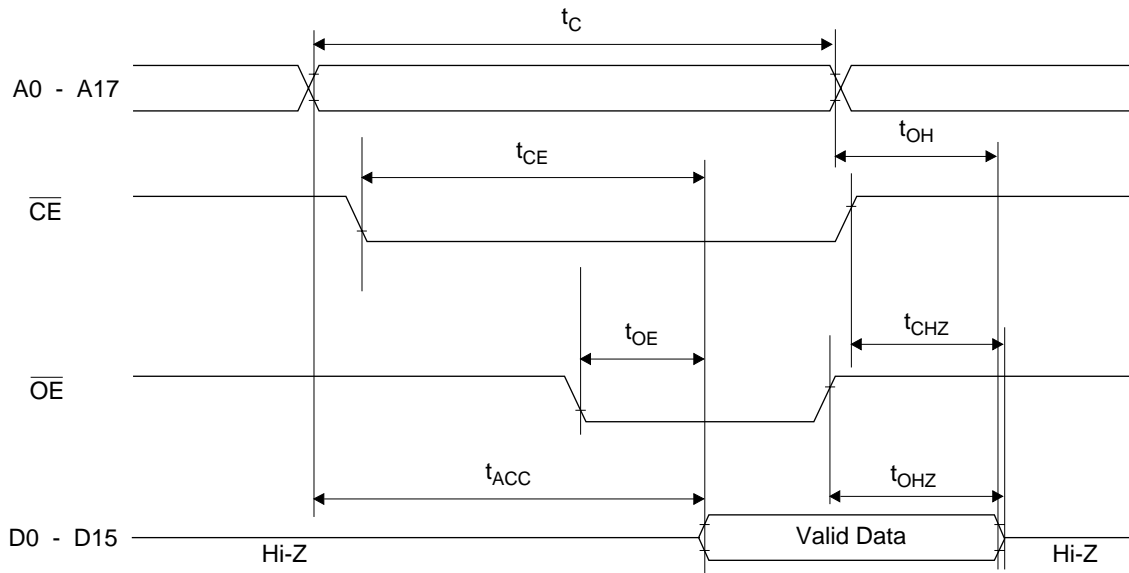
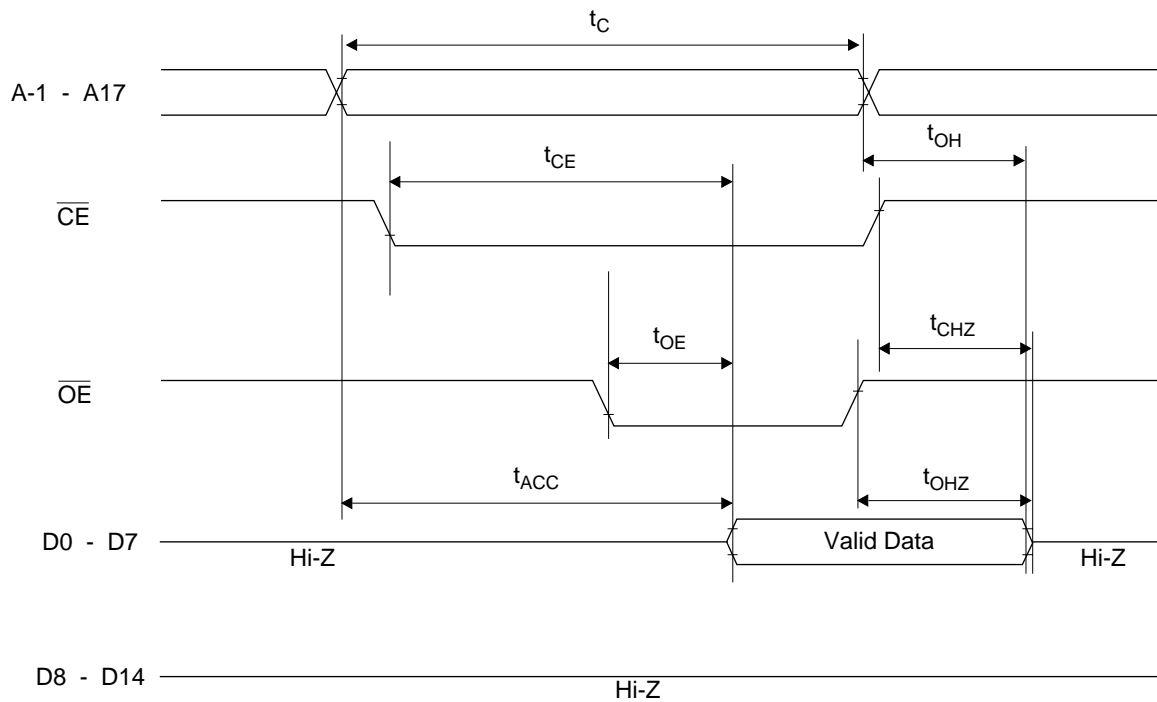
16-Bit Read Mode ($\overline{\text{BYTE}}=\text{V}_{\text{IH}}$)8-Bit Read Mode ($\overline{\text{BYTE}}=\text{V}_{\text{IL}}$)

ELECTRICAL CHARACTERISTICS (Programming operation)

DC Characteristics

(Ta=25°C±5°C)

Parameter	Symbol	Condition	Min.	Typ.	Max.	Unit
Input leakage current	I _{LI}	V _I =V _{CC} +0.5V	-	-	10	μA
V _{PP} power supply current (Program)	I _{PP2}	$\overline{CE}=V_{IL}$	-	-	50	mA
V _{CC} power supply current	I _{CC}	-	-	-	50	mA
Input "H" level	V _{IH}	-	3.0	-	V _{CC} +0.5	V
Input "L" level	V _{IL}	-	-0.5	-	0.8	V
Output "H" level	V _{OH}	I _{OH} =-400μA	2.4	-	-	V
Output "L" level	V _{OL}	I _{OL} =2.1mA	-	-	0.45	V
Program voltage	V _{PP}	-	9.5	9.75	10.0	V
V _{CC} power supply voltage	V _{CC}	-	3.9	4.0	4.1	V

Voltage is relative to V_{SS}

AC Characteristics

(V_{CC}=4.0V±0.1V, V_{pp}=9.75V±0.25V, Ta=25°C±5°C)

Parameter	Symbol	Condition	Min.	Typ.	Max.	Unit
Address set-up time	T _{AS}	-	100	-	-	ns
\overline{OE} set-up time	T _{OES}	-	2	-	-	μs
Data set-up time	T _{DS}	-	100	-	-	ns
Address hold time	T _{AH}	-	2	-	-	μs
Data hold time	T _{DH}	-	100	-	-	ns
Output float delay from \overline{OE}	T _{OHZ}	-	0	-	100	ns
V _{PP} voltage set-up time	T _{VS}	-	2	-	-	μs
Program pulse width	T _{PW}	-	9	10	11	μs
Data valid from \overline{OE}	T _{OE}	-	-	-	100	ns
Address hold from \overline{OE} high	T _{AHO}	-	0	-	-	ns

Pin Check Function

Pin Check Function is to check contact between each device-pin and each socket-lead with EPROM programmer.

Setting up address as the following condition call the preprogrammed codes on device outputs.

(V_{CC}=3.3V±0.3V, $\overline{CE}=\overline{OE}=V_{IL}$, $\overline{BYTE}/V_{pp}=V_{IH}$, Ta=25°C±5°C)

A0	A1	A2	A3	A4	A5	A6	A7	A8	A9	A10	A11	A12	A13	A14	A15	A16	A17	DATA
0	1	0	1	0	1	0	1	0	VH*	0	1	0	1	0	1	0	0	FF00
1	0	1	0	1	0	1	0	1	VH*	1	0	1	0	1	0	1	1	00FF
Other conditions																		FFFF

* :VH=8V±0.25V

Consecutive Programming Waveforms

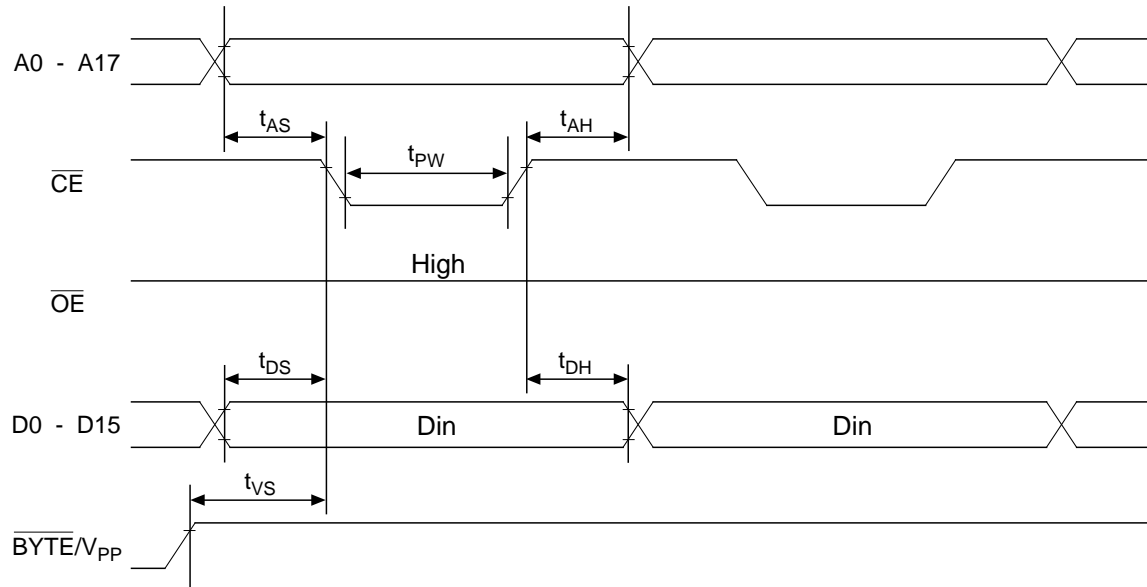

Consecutive Program Verify Waveforms

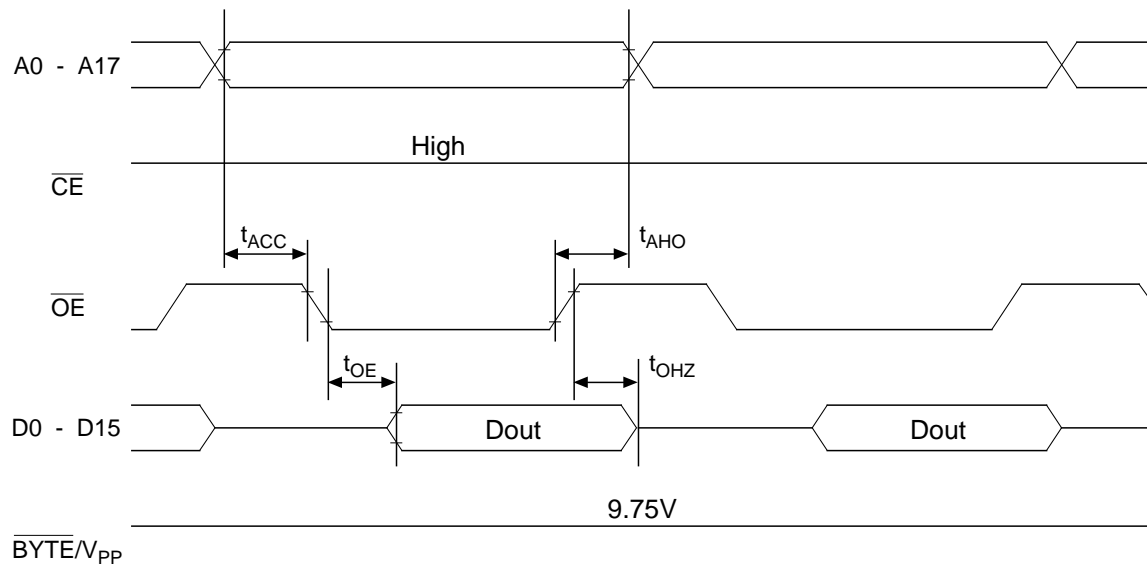

Program and Program Verify Cycle Waveforms

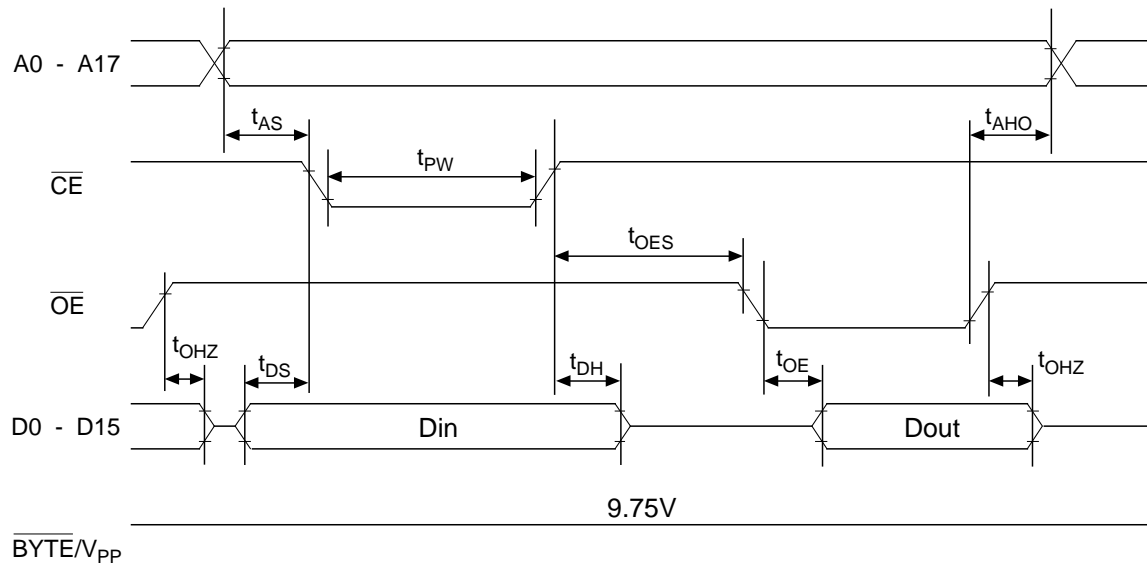

PIN Capacitance

($V_{CC}=3.3V$, $T_a=25^\circ C$, $f=1MHz$)

Parameter	Symbol	Condition	Min.	Typ.	Max.	Unit
Input	C_{IN1}	$V_I=0V$	-	-	12	pF
$\overline{BYTE/V_{PP}}$	C_{IN2}		-	-	60	
Output	C_{OUT}	$V_O=0V$	-	-	15	

Programming / Verify Flow Chart

Programming

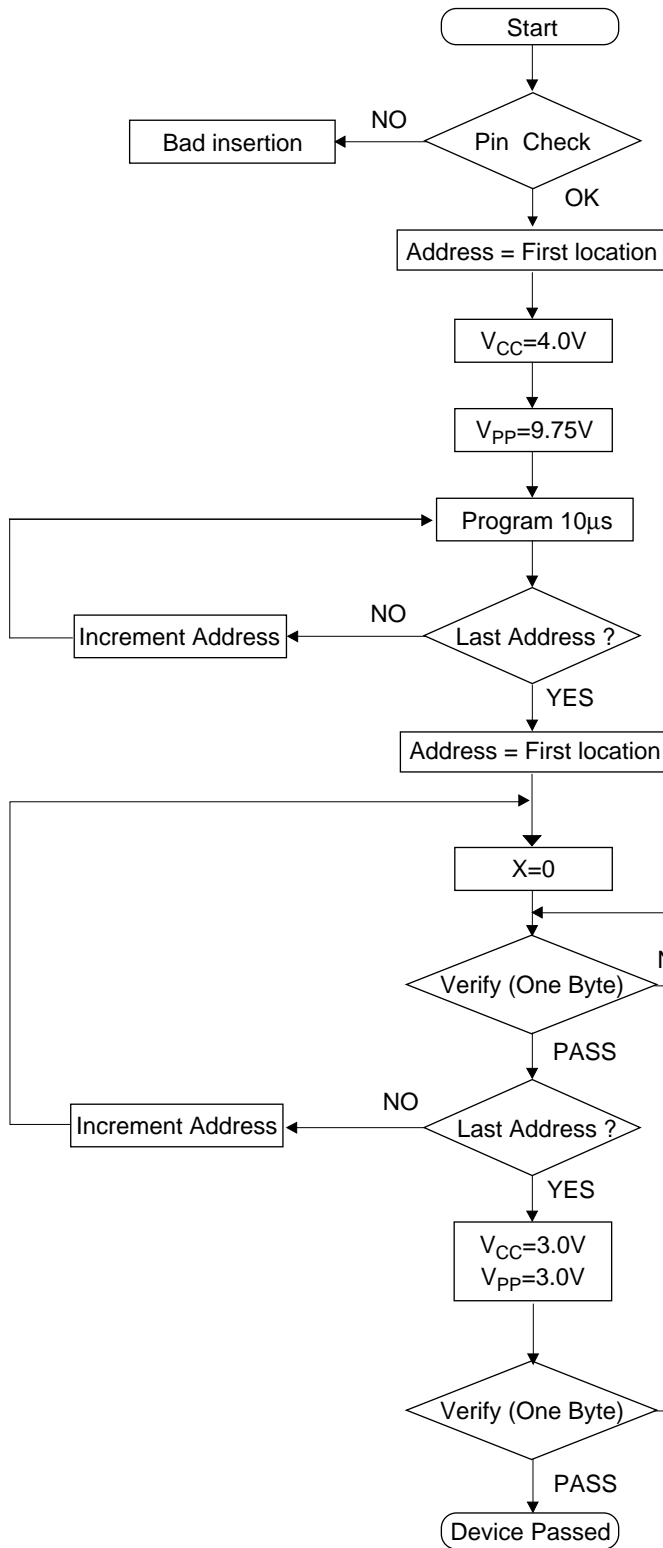

Verify

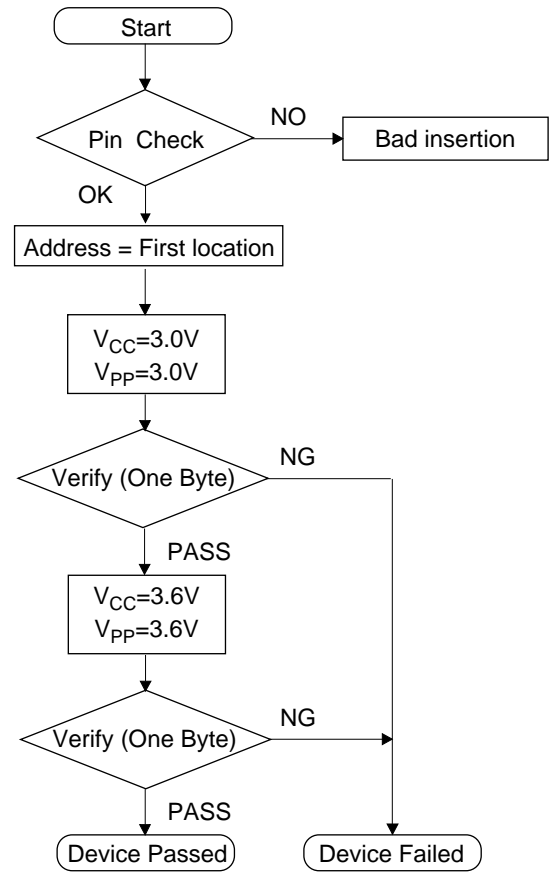

NOTICE

The information contained herein can change without notice owing to product and/or technical improvements. Before using the product, please make sure that the information being referred to is up-to-date.

The outline of action and examples for application circuits described herein have been chosen as an explanation for the standard action and performance of the product. When planning to use the product, please ensure that the external conditions are reflected in the actual circuit, assembly, and program designs.

When designing your product, please use our product below the specified maximum ratings and within the specified operating ranges including, but not limited to, operating voltage, power dissipation, and operating temperature.

Oki assumes no responsibility or liability whatsoever for any failure or unusual or unexpected operation resulting from misuse, neglect, improper installation, repair, alteration or accident, improper handling, or unusual physical or electrical stress including, but not limited to, exposure to parameters beyond the specified maximum ratings or operation outside the specified operating range.

Neither indemnity against nor license of a third party's industrial and intellectual property right, etc. is granted by us in connection with the use of the product and/or the information and drawings contained herein. No responsibility is assumed by us for any infringement of a third party's right which may result from the use thereof.

The products listed in this document are intended for use in general electronics equipment for commercial applications (e.g., office automation, communication equipment, measurement equipment, consumer electronics, etc.). These products are not authorized for use in any system or application that requires special or enhanced quality and reliability characteristics nor in any system or application where the failure of such system or application may result in the loss or damage of property, or death or injury to humans. Such applications include, but are not limited to, traffic and automotive equipment, safety devices, aerospace equipment, nuclear power control, medical equipment, and life-support systems.

Certain products in this document may need government approval before they can be exported to particular countries. The purchaser assumes the responsibility of determining the legality of export of these products and will take appropriate and necessary steps at their own expense for these.

No part of the contents contained herein may be reprinted or reproduced without our prior permission.

All brand, company and product names are the trademarks or registered trademarks of their respective owners.

Copyright 1998 Oki Electric Industry Co., Ltd.
Marketing Communications Team (RB)

OKI

People To People Technology

ADDRESSES & SEMICONDUCTOR WEB SITES

OKI Electric Industry Co., Ltd.,

Device Business Group,
10-3, Shibaura, 4-chome,
Minato-ku, Tokyo 108, Japan,
Tel.: +81-(0)3-5445-6327,
Fax.: +81-(0)3-5445-6328,
<http://www.oki.co.jp/semi/>

OKI Semiconductor Group,

785 North Mary Avenue,
Sunnyvale, CA 94086, U.S.A.,
Tel.: +1-408-720-1900,
Fax.: +1-408-720-1918,
<http://www.okisemi.com/>

OKI Electric Europe GmbH,

Head Office Europe,
Hellersbergstrasse 2,
D-41460 Neuss, Germany,
Tel: +49-2131-15960,
Fax: +49-2131-103539,
<http://www.oki-europe.de/>

OKI Electronics (Hong Kong) Ltd.,

Suite 1901-1&19, Tower 3,
China Hong Kong City,
33 Canton Road, Tsimshatsui,
Kowloon, Hong Kong,
Tel.: +852-2-736-2336,
Fax.: +852-2-736-2395

OKI Semiconductor (Asia) Pte. Ltd.,

78 Shenton Way 09-01,
Singapore 0207,
Tel.: +65-221-3722,
Fax.: +65-323-5376

OKI Semiconductor (Asia) Pte. Ltd.,

Taipei Branch,
7th Fl. No.260, Tun Hwa North Road,
Taipei, Taiwan, R.O.C.,
Sumitomo-Flysun Building,
Tel.: +886-2-2719-2561,
Fax.: +886-2-2715-2892
<http://www.oki.net.tw/>

For further information, please contact: