

INFRARED REMOTE CONTROL TRANSMITTER

DESCRIPTION

The SC50462 is a remote control transmitter utilizing CMOS technology specially designed for use on infrared applications. It has 64 functions and a total of 76 commands can be transmitted. Housed in 24 pins DIP package, SC50462 has 2 address bits.

FEATURES

- * High performance CMOS technology
- * Low power consumption
- * Least external components.
- * Up to 76 instructions
- * Double key operation is possible.

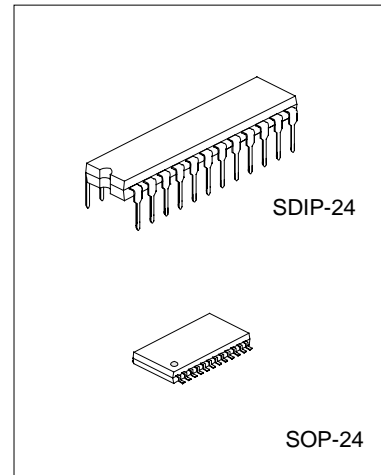

APPLICATIONS

- * Television remote control transmitter
- * Video cassette recorder(VCR) remote control transmitter

ORDERING INFORMATION

SC50462	SDIP-24 Package
SC50462S	SOP-24 Package

BLOCK DIAGRAM

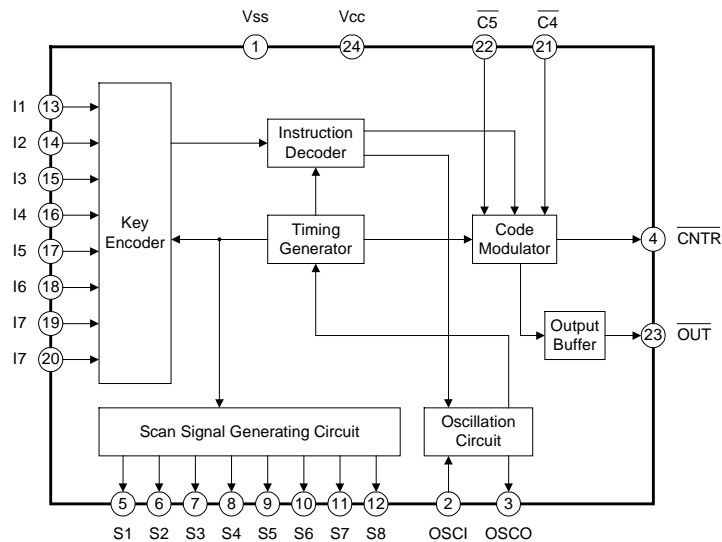

PIN CONFIGURATION

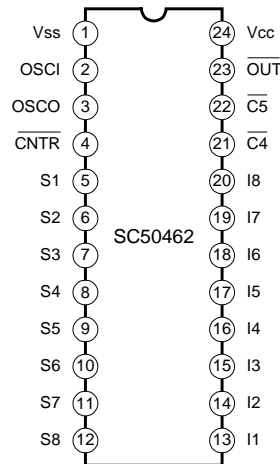

ABSOLUTE MAXIMUM RATINGS (Ta=25°C)

Characteristic	Symbol	Value	Unit
Supply Voltage	V _{CC}	-0.3 ~ 5.5	V
Input Voltage	V _{IN}	V _{SS} -0.3V ~ V _{CC} +0.3V	V
Output Voltage	V _{OUT}	V _{SS} ~ V _{CC}	V
Power Dissipation	P _D	300	mW
Operating Temperature	T _{opr}	-10 ~ +70	°C
Storage Temperature	T _{stg}	-40 ~ +125	°C

ELECTRICAL CHARACTERISTICS (T_{amb}=25°C, V_{CC}=3.0V, V_{SS}=0, Unless otherwise specified)

Parameter	Symbol	Test Conditions	Min	Typ	Max	Unit
Operating Supply Voltage	V _{CC}	T _a =20 ~ 70°C	1.5	3	5	V
Operating Supply Current	I _{CC1}	F _{osc} =455kHz			0.3	mA
Stand-by Current	I _{CC2}				1	μA
Pull-Up Resistor(I1~I8)	R _{up}		100	250	400	kΩ
Pull-Up Resistor(C4 , C5)	R _{up}		200	350	500	kΩ
Output Current(S1~S8)	I _{OL}	V _{OL} =1.2V	-0.2			mA
High level Output Current($\overline{\text{OUT}}$)	I _{OH}	V _{OH} =2V	5			mA
Low level Output Current($\overline{\text{OUT}}$)	I _{OL}	V _{OL} =1V	-3			mA
High level Output Current($\overline{\text{CNTR}}$)	I _{OH}	V _{OH} =2V	1			mA
Low level Output Current($\overline{\text{CNTR}}$)	I _{OL}	V _{OL} =1V	-3			mA

— HANGZHOU SILAN MICROELECTRONICS JOINT-STOCK CO.,LTD —

Rev. 2.1 2002-02-28

PIN DESCRIPTION

Pin No.	Pin Name	Input/output	Description
1,24	Vss,Vcc	Power	Power Supply: Vcc=3.0V,Vss=0V
2,3	OSCI,OSCO	I/O	Oscillator Input/Output Pin, 455 or 480kHz Crystal is connected between these pins.
4	$\overline{\text{CNTR}}$	O	Transmitting Indicator. An LED and resistor are connected from this pin to Vcc.
5~12	S1~S8	O	Key Scan Signal Output pins.
13~20	I1~I8	I	Key Scan Signal Input pins.
21,22	$\overline{\text{C4}}$, $\overline{\text{C5}}$	I	Custom Code
23	$\overline{\text{OUT}}$	O	Modulation Pin

FUNCTIONAL DESCRIPTION

SC50462 is a sending signal IC on infrared remote control. Consisting of timing generating circuit, scan signal generating circuit, key input encoder, instruction decoder, custom code circuit, code encoder, and output buffer. It has 8*8 key matrix input and custom code with 16 bit PCM which shows 76 instructions. 76 Instructions are divided in 64 one shot signal and 12 2-shot signal.

When Input Signal(I1~I8) and/or in combination with the Scan Signals(S1~S8) are activated, SC50462 checks the ID and the Custom Code Bits-- $\overline{\text{C4}}$ and $\overline{\text{C5}}$ --setting before finally sending out the remote control signal.

1. $\overline{\text{CNTR}}$ OUTPUT

The $\overline{\text{CNTR}}$ Pin is the LED transmission Indicator. This means that Whenever a valid transmission is sent, the LED lights up. The $\overline{\text{CNTR}}$ output becomes "L" in the 7th pulse-rising and "H" in the 17th pulse-rising.

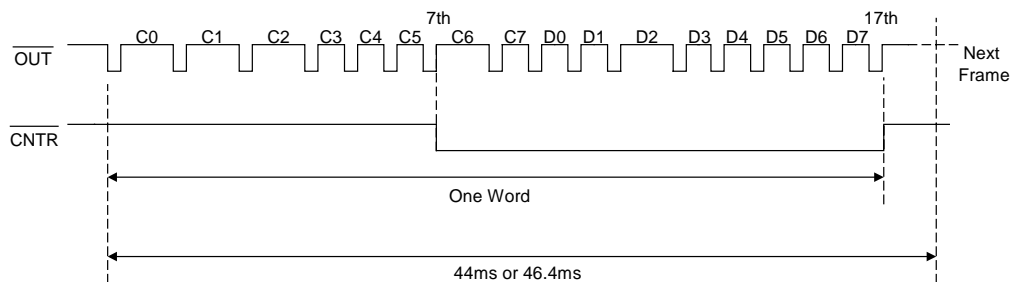

Note: Oscillator Frequency=480 or 455kHz

2. OSCILLATING CIRCUIT

An oscillator circuit may be constructed by using a 480kHz or 455kHz Crystal Resonator and two capacitors. Please refer to the following diagram. The carrier frequency transmitted is 40kHz or 37.9kHz. Unless any legal key input is activated, the oscillation is automatically stopped. Thus, power consumption is considerably reduced.

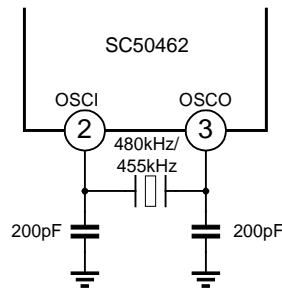

3. KEY INPUT

A total of 64 keys may be connected by Input Pins(I1~I8) and Output Pins(S1~S8) to form an 8x8 Key Matrix. Double key operation is possible for only one of the keys—SW25~SW28 in combination with any one of the keys – SW11~SW13. Any other key combination are regards as illegal and will not generate any activity. Thus, only the following key combinations may be used for the doubled key operation:

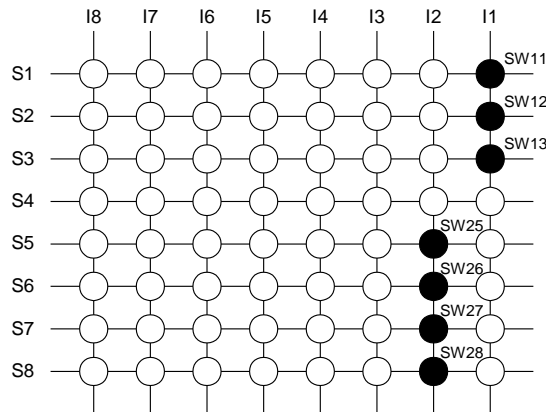

- | | |
|---------------|---------------|
| SW25 and SW11 | SW26 and SW11 |
| SW25 and SW12 | SW26 and SW12 |
| SW25 and SW13 | SW26 and SW13 |
| SW27 and SW11 | SW28 and SW11 |
| SW27 and SW12 | SW28 and SW12 |
| SW27 and SW13 | SW28 and SW13 |

Note:

SC50462 permits two keys function but only “●” key are allowed.

When you push one key of SW11/12/13, you can push with another key of SW25/26/27/28. Otherwise, other conditions are illegal.

4. TRANSMISSION CODE

The transmission Code consists of 16 bits, namely: 8 bits custom code(C0-C7) and 8 bits data code (D0-D7). Please refer to the table below:

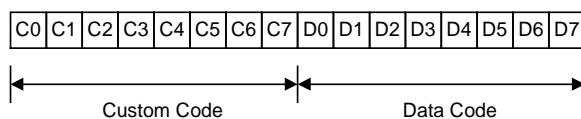

One frame of the Transmission Code

If a Single Shot Key is depressed, data Codes—D6 and d7 will be given the value of (0,0).Please refer to the table1.If a valid double key operation is performed, the data codes will receive the values described in Table 2.

Scan Output	Data			Octal display
	D0	D1	D2	
S1	0	0	0	0
S2	1	0	0	1
S3	0	1	0	2
S4	1	1	0	3
S5	0	0	1	4
S6	1	0	1	5
S7	0	1	1	6
S8	1	1	1	7
Key Input	Data			Octal display
	D3	D4	D5	
I1	0	0	0	0
I2	1	0	0	1
I3	0	1	0	2
I4	1	1	0	3
I5	0	0	1	4
I6	1	0	1	5
I7	0	1	1	6
I8	1	1	1	7

Table 1: Key Matrix/Code

Scan Output		Data Code								Octal Display		
		D0	D1	D2	D3	D4	D5	D6	D7	D0~D2	D3~D5	D6~D7
S1/I1 (SW11)	S5/I2 (SW25)	0	0	1	1	0	0	1	0	4	1	1
	S6/I2 (SW26)	1	0	1	1	0	0	1	0	5	1	1
	S7/I2 (SW27)	0	1	1	1	0	0	1	0	6	1	1
	S8/I2 (SW28)	1	1	1	1	0	0	1	0	7	1	1
S2/I1 (SW12)	S5/I2 (SW25)	0	0	1	1	0	0	0	1	4	1	2
	S6/I2 (SW26)	1	0	1	1	0	0	0	1	5	1	2
	S7/I2 (SW27)	0	1	1	1	0	0	0	1	6	1	2
	S8/I2 (SW28)	1	1	1	1	0	0	0	1	7	1	2
S3/I1 (SW13)	S5/I2 (SW25)	0	0	1	1	0	0	1	1	4	1	3
	S6/I2 (SW26)	1	0	1	1	0	0	1	1	5	1	3
	S7/I2 (SW27)	0	1	1	1	0	0	1	1	6	1	3
	S8/I2 (SW28)	1	1	1	1	0	0	1	1	7	1	3

Table 2: Double Key Signal/Code

5. CUSTOM CODE

SC50462 has a total of 8 bits custom code (C0~C7). Custom Code Bits –C4 and C5 can be externally selected using the $\overline{C4}$ and $\overline{C5}$ Terminals. The $\overline{C4}$ and $\overline{C5}$ pins are inversed; therefore, if the $\overline{C4}$ and $\overline{C5}$ terminals are pulled HIGH, then the Custom Code Bits—C4 and C5 would have the Value(0,0). Likewise, when pulled LOW, then C4 and C5 bits will be (1,1),The other Customs Code Bits,namely:C0~C3 and C6,C7 are fixed at (1,1,1,0) and (1,0):

The waveform of bits are given below:

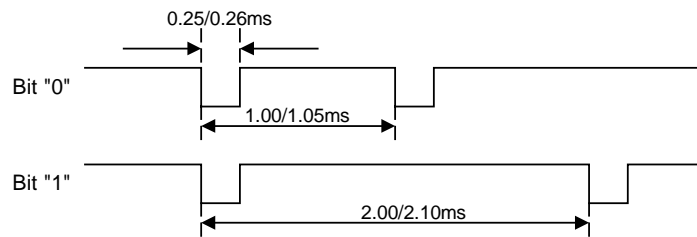

Note: Oscillator Frequency=480 or 455kHz

6. KEY ON TIMING

When any key is pressed, the output pin-- $\overline{\text{OUT}}$ continuously generates the waveform described below until the key is released.

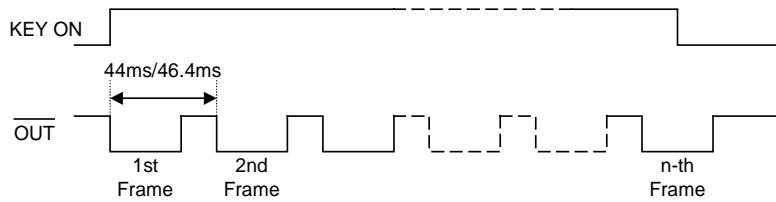

Note: Oscillator Frequency=480 or 455kHz

7. CARRIER WAVEFORM

The following is the carrier waveform diagram. A bit modulates 10 carrier waveforms.

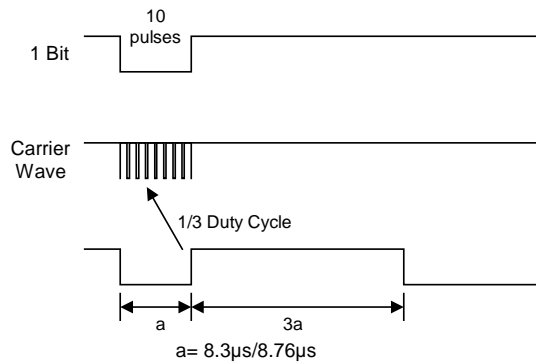

Note: Oscillator Frequency=480 or 455kHz

TYPICAL APPLICATION CIRCUIT

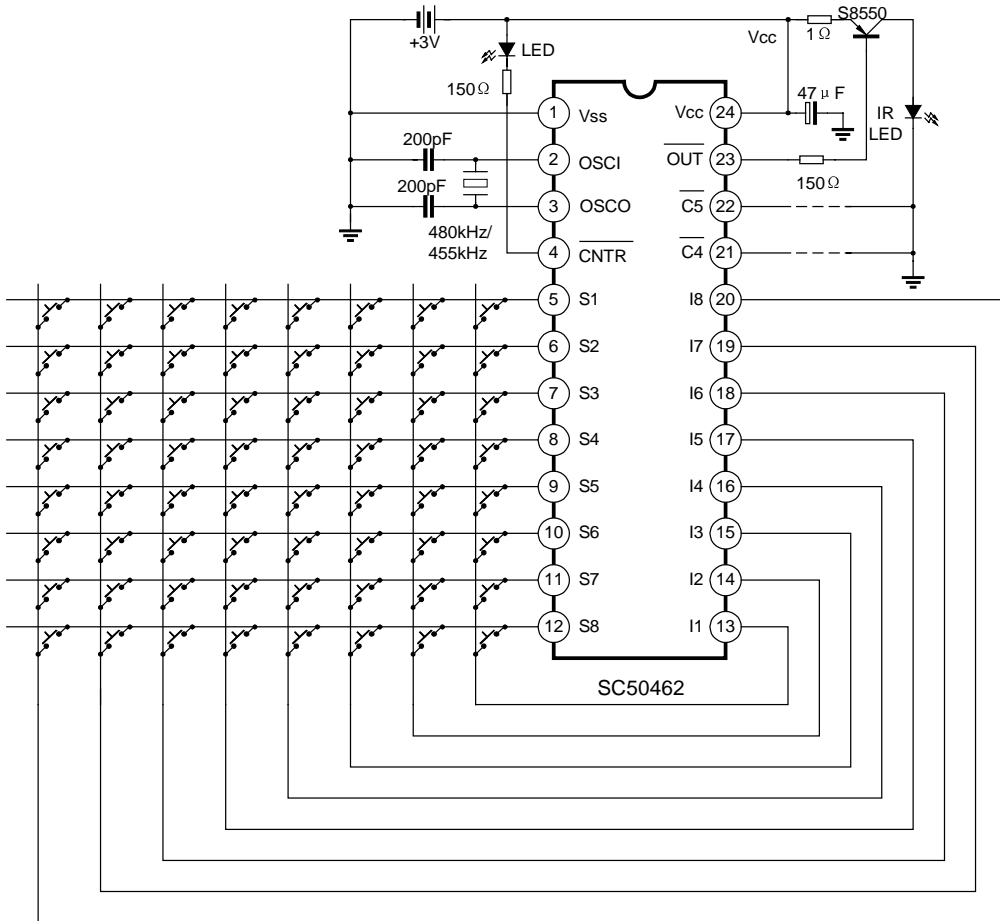

CHIP TOPOGRAPHY

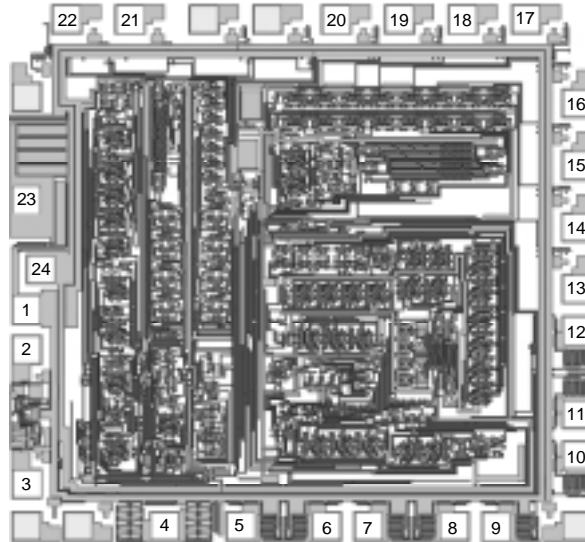

size: 1.96 x 2.07mm²

PAD COORDINATES (Unit: μm)

No.	Symbol	X	Y	No.	Symbol	X	Y
1	P1	-904.75	-122.00	13	P13	906.00	54.50
2	P2	-904.75	-258.25	14	P14	906.00	154.00
3	P3	-904.75	-709.00	15	P15	906.00	362.50
4	P4	-450.25	-851.25	16	P16	906.00	571.00
5	P5	-200.25	-851.25	17	P17	739.00	854.75
6	P6	80.75	-851.25	18	P18	530.50	854.75
7	P7	220.75	-851.25	19	P19	322.00	854.75
8	P8	501.75	-851.25	20	P20	113.50	854.75
9	P9	641.75	-851.25	21	P21	-564.75	854.75
10	P10	906.00	-615.50	22	P22	-773.25	854.75
11	P11	906.00	-475.50	23	P23	-904.75	248.00
12	P12	906.00	-194.50	24	P24	-857.00	12.00

Note: The original point of the coordinate is the die center.

PCB WIRE LAYOUT SCHEMATIC:

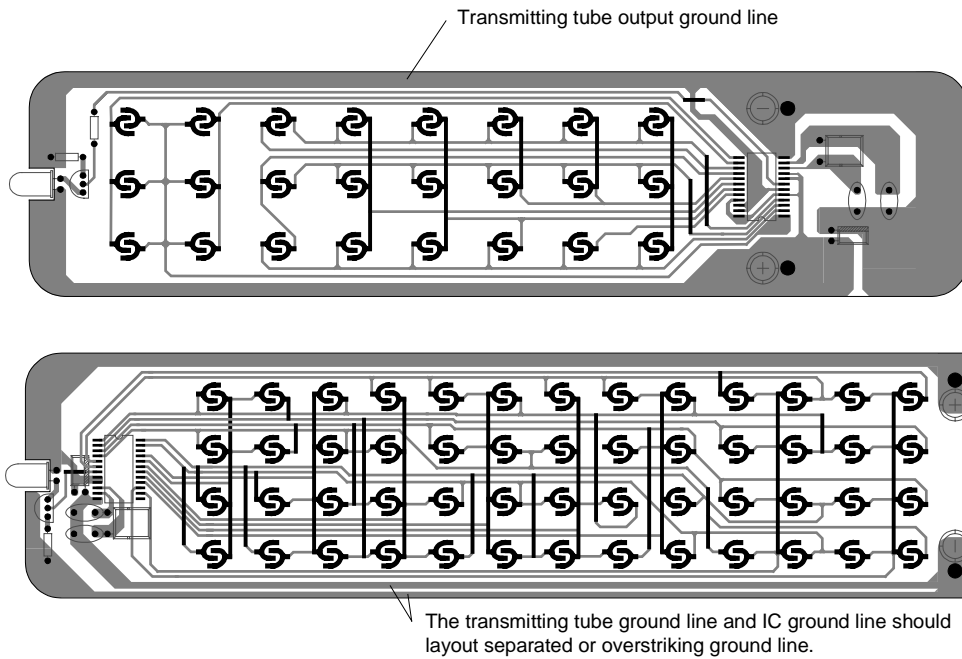

The above IC only use to hint, not to specified.

Note: :

- * In wire layout, the power filter capacitor should near to IC.
- * In wire layout, should avoid power line and ground line too long.
- * Recommended infrared transmit unit and IC ground line should layout separated, or overstriking lines.
- * The emitter of triode connect $1\ \Omega$ resistor at least.

PACKAGE OUTLINE

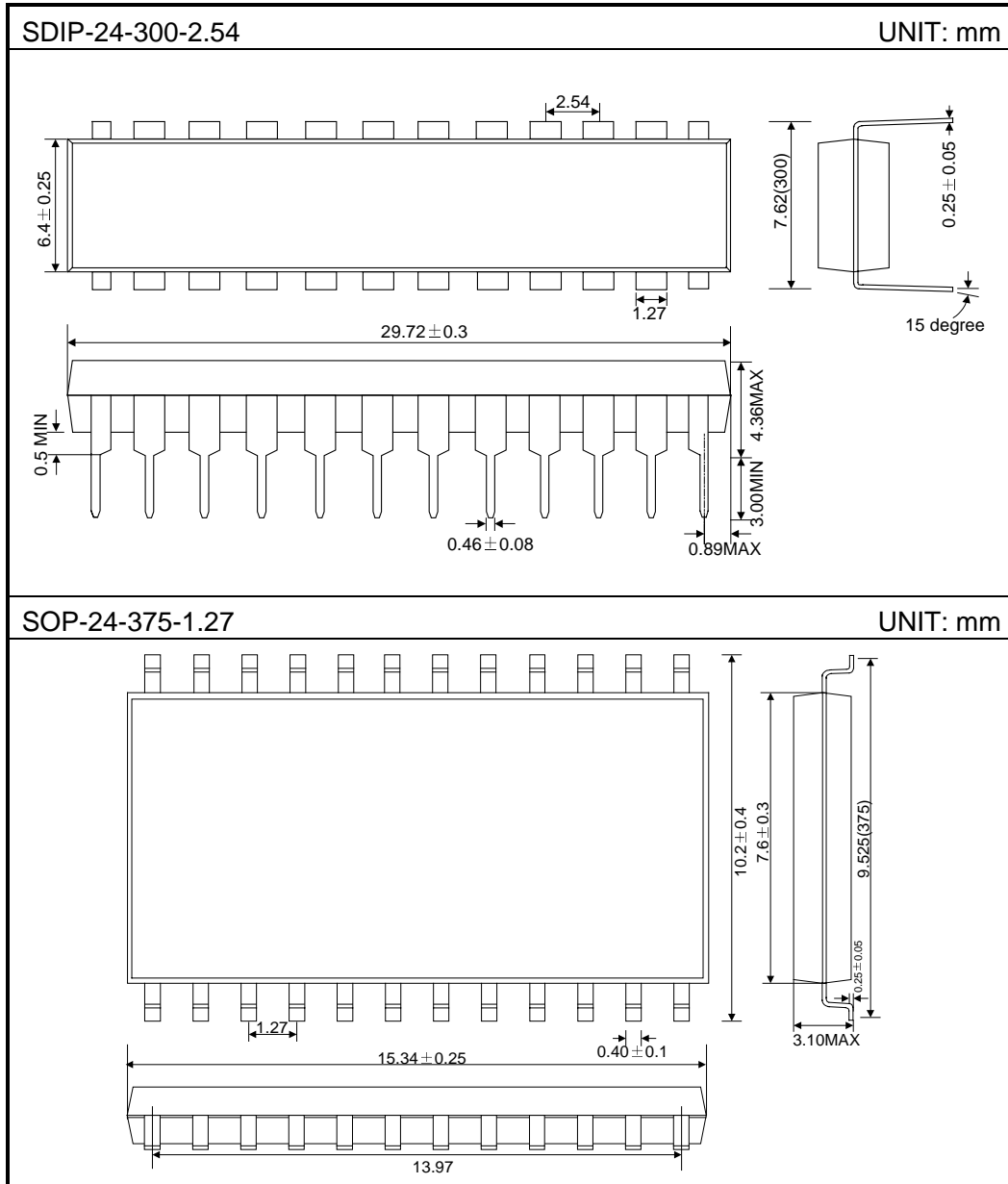

Attach

Revision History

Data	REV	Description	Page
2001.11.08	2.0		
2002.02.28	2.1	Modify the "Absolute maximum rating "	2
		Modify the "Typical application circuit "	8
		Add the "PCB wire layout schematic"	10
		Modify the "Package outline"	11