



Integrated Device Technology, Inc.

256K x 32 CMOS STATIC RAM MODULE

IDT7MP4045
IDT7MP4145

- High density 1 megabyte static RAM module (IDT7MP4145 upgradeable to 4 megabyte, IDT7MP4120)
- Low profile 64 pin ZIP (Zig-zag In-line vertical Package) or 64 pin SIMM (Single In-line Memory Module) for IDT7MP4045 and 72 pin SIMM (Single In-line Memory Module) for IDT7MP4145
- Very fast access time: 15ns (max.)
- Surface mounted plastic components on an epoxy laminate (FR-4) substrate
- Single 5V ($\pm 10\%$) power supply
- Multiple GND pins and decoupling capacitors for maximum noise immunity
- Inputs/outputs directly TTL-compatible

PIN CONFIGURATION – 7MP4045⁽¹⁾

| | | | | |
|-------------------|----|-------------------------------|----|--|
| | 1 | GND | | |
| PD ₀ | 2 | | 3 | PD ₁ PD ₀ – GND |
| I/O ₀ | 4 | | 5 | I/O ₈ PD ₁ – GND |
| I/O ₁ | 6 | | 7 | I/O ₉ |
| I/O ₂ | 8 | | 9 | I/O ₁₀ |
| I/O ₃ | 10 | | 11 | I/O ₁₁ |
| VCC | 12 | | 13 | A ₀ |
| A ₇ | 14 | | 15 | A ₁ |
| A ₈ | 16 | | 17 | A ₂ |
| A ₉ | 18 | | 19 | I/O ₁₂ |
| I/O ₄ | 20 | | 21 | I/O ₁₃ |
| I/O ₅ | 22 | | 23 | I/O ₁₄ |
| I/O ₆ | 24 | | 25 | I/O ₁₅ |
| I/O ₇ | 26 | | 27 | GND |
| \overline{WE} | 28 | | 29 | A ₁₅ |
| A ₁₄ | 30 | | 31 | \overline{CS}_2 |
| \overline{CS}_1 | 32 | ZIP, SIMM TOP VIEW | | |
| \overline{CS}_3 | 34 | | 33 | \overline{CS}_4 |
| A ₁₆ | 36 | | 35 | A ₁₇ |
| GND | 38 | | 37 | \overline{OE} |
| I/O ₁₆ | 40 | | 39 | I/O ₂₄ |
| I/O ₁₇ | 42 | | 41 | I/O ₂₅ |
| I/O ₁₈ | 44 | | 43 | I/O ₂₆ |
| I/O ₁₉ | 46 | | 45 | I/O ₂₇ |
| A ₁₀ | 48 | | 47 | A ₃ |
| A ₁₁ | 50 | | 49 | A ₄ |
| A ₁₂ | 52 | | 51 | A ₅ |
| A ₁₃ | 54 | | 53 | VCC |
| I/O ₂₀ | 56 | | 55 | A ₆ |
| I/O ₂₁ | 58 | | 57 | I/O ₂₈ |
| I/O ₂₂ | 60 | | 59 | I/O ₂₉ |
| I/O ₂₃ | 62 | | 61 | I/O ₃₀ |
| GND | 64 | | 63 | I/O ₃₁ |

2703 drw 01

NOTE:

1. Pins 2 and 3 (PD₀ and PD₁) are read by the user to determine the density of the module. If PD₀ reads GND and PD₁ reads GND, then the module has a 256K depth.

DESCRIPTION:

The IDT7MP4045/4145 is a 256K x 32 static RAM module constructed on an epoxy laminate (FR-4) substrate using 8 256K x 4 static RAMs in plastic SOJ packages. Availability of four chip select lines (one for each group of two RAMs) provides byte access. The IDT7MP4045 is available with access time as fast as 10ns with minimal power consumption.

The IDT7MP4045 is packaged in a 64 pin FR-4 ZIP (Zig-zag In-line vertical Package) or a 64 pin SIMM (Single In-line Memory Module) where as the 7MP4145 is packaged in a 72 pin SIMM (Single In-line Memory Module). The 4045 ZIP configuration allows 64 pins to be placed on a package 3.65 inches long and 0.365 inches wide. The 7MP4045 ZIP is only 0.585 inches high, this low profile package is ideal for systems with minimum board spacing while the SIMM configuration allows use of edge mounted sockets to secure the module.

All inputs and outputs of the IDT7MP4045/4145 are TTL-compatible and operate from a single 5V supply. Full asynchronous circuitry requires no clocks or refresh for operation and provides equal access and cycle times for ease of use.

Identification pins are provided for applications in which different density versions of the module are used. In this way, the target system can read the respective levels of PD pins to determine a 256K depth.

The contact pins are plated with 100 micro-inches of nickel covered by 30 micro-inches minimum of selective gold.

FUNCTIONAL BLOCK DIAGRAM

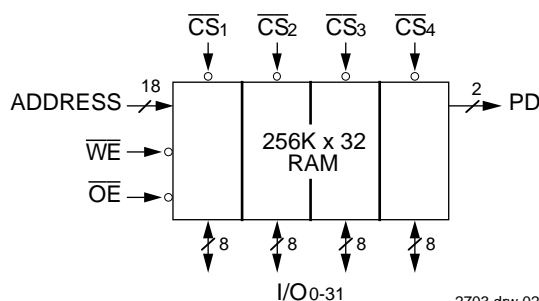

2703 drw 02

PIN NAMES

| | |
|---------------------|----------------------|
| I/O ₀₋₃₁ | Data Inputs/Outputs |
| A ₀₋₁₇ | Addresses |
| \overline{CS}_1-4 | Chip Selects |
| \overline{WE} | Write Enable |
| \overline{OE} | Output Enable |
| PD ₀₋₁ | Depth Identification |
| VCC | Power |
| GND | Ground |
| NC | No Connect |

2703 tbl 01

The IDT logo is a registered trademark of Integrated Device Technology Inc.

COMMERCIAL TEMPERATURE RANGE

SEPTEMBER 1996

CAPACITANCE (TA = +25°C, F = 1.0MHz)

| Symbol | Parameter ⁽¹⁾ | Conditions | Max. | Unit |
|--------|---------------------------------------|-------------|------|------|
| CIN(C) | Input Capacitance (CS) | V(IN) = 0V | 20 | pF |
| CIN(A) | Input Capacitance (Address & Control) | V(IN) = 0V | 70 | pF |
| CI/O | I/O Capacitance | V(OUT) = 0V | 12 | pF |

NOTE: 2703 tbl 02
1. This parameter is guaranteed by design but not tested.

RECOMMENDED DC OPERATING CONDITIONS

| Symbol | Parameter | Min. | Typ. | Max. | Unit |
|--------|--------------------|---------------------|------|------|------|
| VCC | Supply Voltage | 4.5 | 5.0 | 5.5 | V |
| GND | Supply Voltage | 0 | 0 | 0 | V |
| VIH | Input High Voltage | 2.2 | — | 6.0 | V |
| VIL | Input Low Voltage | -0.5 ⁽¹⁾ | — | 0.8 | V |

NOTE: 2703 tbl 03
1. VIL (min) = -1.5V for pulse width less than 10ns.

RECOMMENDED OPERATING TEMPERATURE AND SUPPLY VOLTAGE

| Grade | Ambient Temperature | GND | Vcc |
|------------|---------------------|-----|------------|
| Commercial | 0°C to +70°C | 0V | 5.0V ± 10% |

2703 tbl 04

TRUTH TABLE

| Mode | CS | OE | WE | Output | Power |
|---------|----|----|----|---------|---------|
| Standby | H | X | X | High-Z | Standby |
| Read | L | L | H | DATAOUT | Active |
| Write | L | X | L | DATAIN | Active |
| Read | L | H | H | High-Z | Active |

2703 tbl 05

ABSOLUTE MAXIMUM RATINGS⁽¹⁾

| Symbol | Rating | Value | Unit |
|--------|--------------------------------------|--------------|------|
| VTERM | Terminal Voltage with Respect to GND | -0.5 to +7.0 | V |
| TA | Operating Temperature | 0 to +70 | °C |
| TBIAS | Temperature Under Bias | -10 to +85 | °C |
| TSTG | Storage Temperature | -55 to +125 | °C |
| IOUT | DC Output Current | 50 | mA |

NOTE: 2703 tbl 06
1. Stresses greater than those listed under ABSOLUTE MAXIMUM RATINGS may cause permanent damage to the device. This is a stress rating only and functional operation of the device at these or any other conditions above those indicated in the operational sections of this specification is not implied. Exposure to absolute maximum rating conditions for extended periods may affect reliability.

PIN CONFIGURATION – 7MP4145⁽¹⁾

| | | | | |
|-------|----|----|-------|------------|
| NC | 2 | 1 | NC | PD0 - GND |
| PD3 | 4 | 3 | PD2 | PD1 - GND |
| PD0 | 6 | 5 | GND | PD2 - OPEN |
| I/O0 | 8 | 7 | PD1 | PD3 - OPEN |
| I/O1 | 10 | 9 | I/O8 | |
| I/O2 | 12 | 11 | I/O9 | |
| I/O3 | 14 | 13 | I/O10 | |
| VCC | 16 | 15 | I/O11 | |
| A7 | 18 | 17 | A0 | |
| A8 | 20 | 19 | A1 | |
| A9 | 22 | 21 | A2 | |
| I/O4 | 24 | 23 | I/O12 | |
| I/O5 | 26 | 25 | I/O13 | |
| I/O6 | 28 | 27 | I/O14 | |
| I/O7 | 30 | 29 | I/O15 | |
| WE | 32 | 31 | GND | |
| A14 | 34 | 33 | A15 | |
| CS1 | 36 | 35 | CS2 | |
| CS3 | 38 | 37 | CS4 | |
| A16 | 40 | 39 | A17 | |
| GND | 42 | 41 | OE | |
| I/O16 | 44 | 43 | I/O24 | |
| I/O17 | 46 | 45 | I/O25 | |
| I/O18 | 48 | 47 | I/O26 | |
| I/O19 | 50 | 49 | I/O27 | |
| A10 | 52 | 51 | A3 | |
| A11 | 54 | 53 | A4 | |
| A12 | 56 | 55 | A5 | |
| A13 | 58 | 57 | VCC | |
| I/O20 | 60 | 59 | A6 | |
| I/O21 | 62 | 61 | I/O28 | |
| I/O22 | 64 | 63 | I/O29 | |
| I/O23 | 66 | 65 | I/O30 | |
| GND | 68 | 67 | I/O31 | |
| NC | 70 | 69 | NC | |
| NC | 72 | 71 | NC | |

**SIMM
TOP VIEW**

2703 drw 15

NOTE:
1. Pins 3,4,6, and 7 (PD0-3) are read by the user to determine the density of the module. If PD0, PD1 read GND and PD2, PD3 read OPEN, then the module has a 256K depth.

DC ELECTRICAL CHARACTERISTICS

(VCC = 5.0V ±10%, TA = 0°C to +70°C)

| Symbol | Parameter | Test Conditions | Min. | Max. | Unit |
|--------|-------------------------------------|---|------|------|------|
| ILI | Input Leakage (Address and Control) | VCC = Max.; VIN = GND to VCC | — | 80 | μA |
| ILI | Input Leakage (Data) | VCC = Max.; VIN = GND to VCC | — | 10 | μA |
| ILO | Output Leakage | VCC = Max.; CS = VIH, VOUT = GND to VCC | — | 10 | μA |
| VOL | Output LOW | VCC = Min., IOL = 8mA | — | 0.4 | V |
| VOH | Output HIGH | VCC = Min., IOH = -4mA | 2.4 | — | V |

2703 tbl 07

| Symbol | Parameter | Test Conditions | Max. | Unit |
|--------|-----------------------------|--|------|------|
| ICC | Dynamic Operating Current | f = fMAX; CS = VIL VCC = Max.; Output Open | 1360 | mA |
| ISB | Standby Supply Current | CS ≥ VIH, VCC = Max. Outputs Open, f = fMAX | 480 | mA |
| ISB1 | Full Standby Supply Current | CS ≥ VCC - 0.2V; f = 0 VIN > VCC - 0.2V or < 0.2V | 120 | mA |

2703 tbl

AC TEST CONDITIONS

| | |
|-------------------------------|-----------------|
| Input Pulse Levels | GND to 3.0V |
| Input Rise/Fall Times | 5ns |
| Input Timing Reference Levels | 1.5V |
| Output Reference Levels | 1.5V |
| Output Load | See Figures 1-4 |

2703 tbl 09

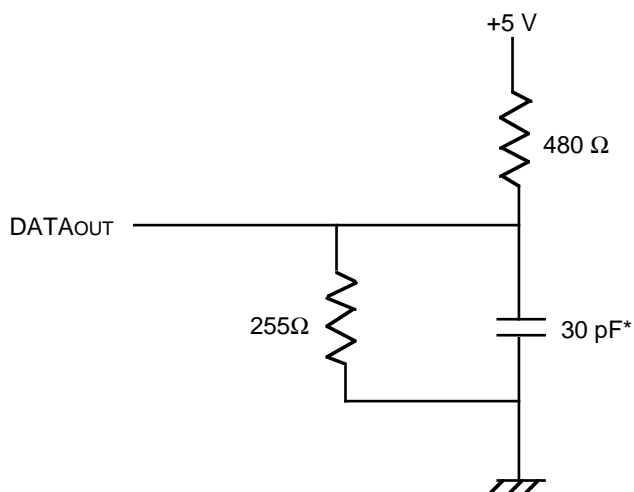

*Includes scope and jig.

Figure 1. Output Load

2703 drw 03

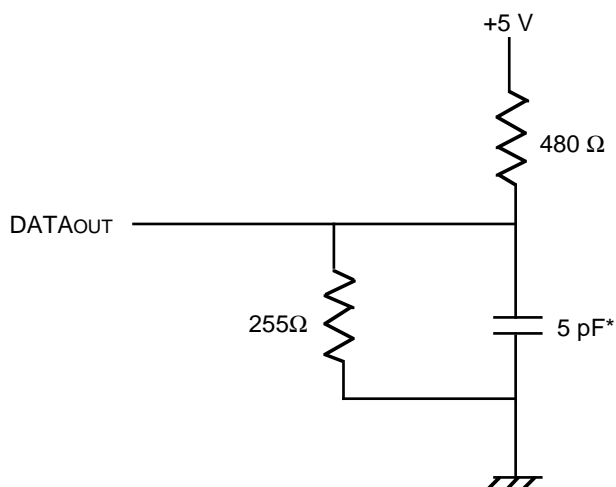

Figure 2. Output Load
(for tOLZ, tOHZ, tCHZ, tCLZ, tWHZ, tOW)

2703 drw 04

AC ELECTRICAL CHARACTERISTICS

(V_{CC} = 5V ±10%, T_A = 0°C to +70°C)

| Symbol | Parameter | '4045SxxZ, '4045/4145SxxM | | | | Unit |
|---------------------------------|------------------------------------|---------------------------|------|------|------|------|
| | | -15 | | -20 | | |
| | | Min. | Max. | Min. | Max. | |
| Read Cycle | | | | | | |
| t _{RC} | Read Cycle Time | 15 | — | 20 | — | ns |
| t _{AA} | Address Access Time | — | 15 | — | 20 | ns |
| t _{ACS} | Chip Select Access Time | — | 15 | — | 20 | ns |
| t _{CLZ} ⁽¹⁾ | Chip Select to Output in Low-Z | 3 | — | 5 | — | ns |
| t _{OE} | Output Enable to Output Valid | — | 8 | — | 10 | ns |
| t _{OLZ} ⁽¹⁾ | Output Enable to Output in Low-Z | 0 | — | 0 | — | ns |
| t _{CHZ} ⁽¹⁾ | Chip Deselect to Output in High-Z | — | 8 | — | 10 | ns |
| t _{OHZ} ⁽¹⁾ | Output Disable to Output in High-Z | — | 8 | — | 10 | ns |
| t _{OH} | Output Hold from Address Change | 3 | — | 3 | — | ns |
| t _{PU} ⁽¹⁾ | Chip Select to Power-Up Time | 0 | — | 0 | — | ns |
| t _{PD} ⁽¹⁾ | Chip Deselect to Power-Down Time | — | 15 | — | 20 | ns |
| Write Cycle | | | | | | |
| t _{WC} | Write Cycle Time | 15 | — | 20 | — | ns |
| t _{CW} | Chip Select to End-of-Write | 12 | — | 15 | — | ns |
| t _{AW} | Address Valid to End-of-Write | 12 | — | 15 | — | ns |
| t _{AS} | Address Set-up Time | 0 | — | 0 | — | ns |
| t _{WP} | Write Pulse Width | 12 | — | 15 | — | ns |
| t _{WR} | Write Recovery Time | 0 | — | 0 | — | ns |
| t _{WHZ} ⁽¹⁾ | Write Enable to Output in High-Z | — | 8 | — | 13 | ns |
| t _{DW} | Data to Write Time Overlap | 10 | — | 12 | — | ns |
| t _{DH} | Data Hold from Write Time | 0 | — | 0 | — | ns |
| t _{OW} ⁽¹⁾ | Output Active from End-of-Write | 0 | — | 0 | — | ns |

NOTE:

1. This parameter is guaranteed by design but not tested.

2703 tbl 11

TIMING WAVEFORM OF READ CYCLE NO. 1⁽¹⁾

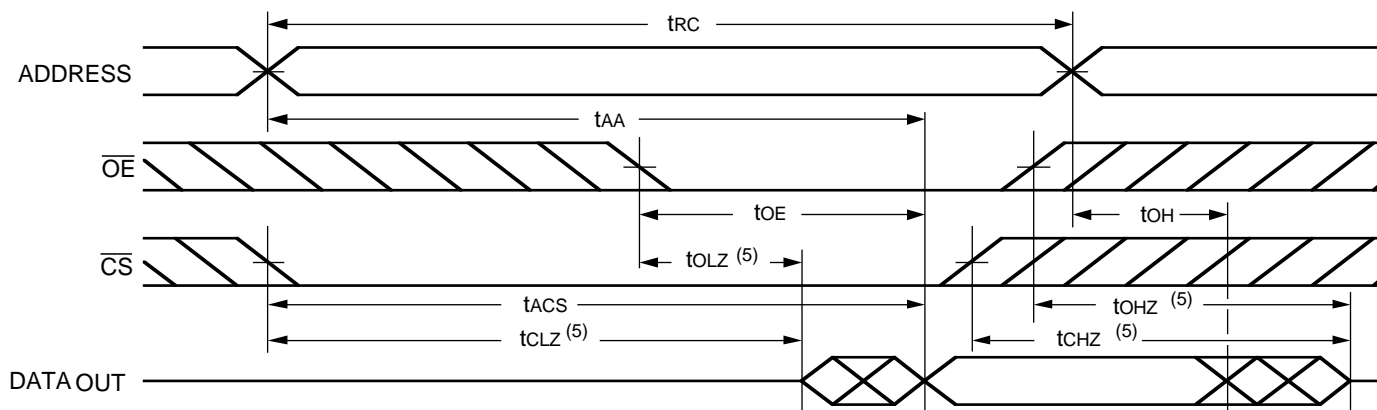

2703 drw 07

TIMING WAVEFORM OF READ CYCLE NO. 2^(1,2,4)

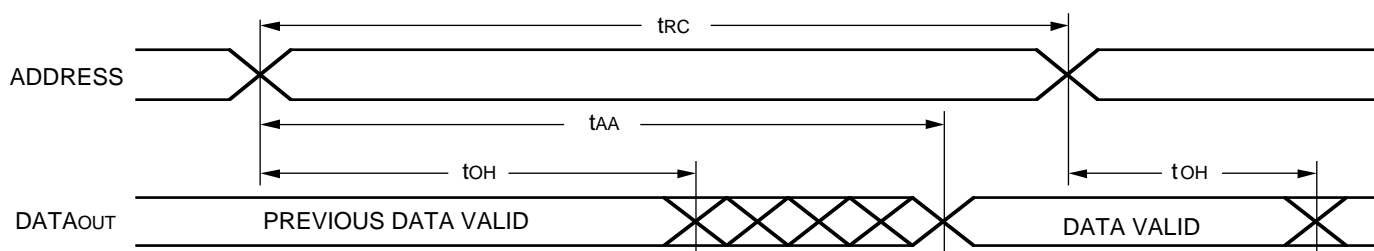

2703 drw 08

TIMING WAVEFORM OF READ CYCLE NO. 3^(1,3,4)

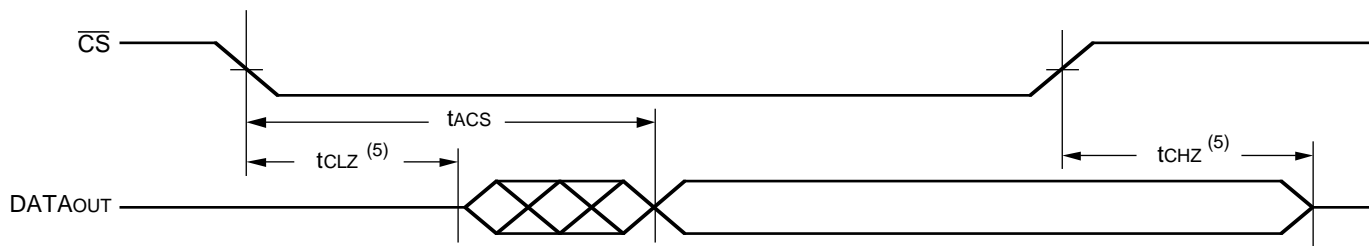

2703 drw 06

NOTES:

1. \overline{WE} is HIGH for Read Cycle.
2. Device is continuously selected. $\overline{CS} = V_{IL}$.
3. Address valid prior to or coincident with \overline{CS} transition LOW.
4. $\overline{OE} = V_{IL}$.
5. Transition is measured $\pm 200\text{mV}$ from steady state. This parameter is guaranteed by design, but not tested.

TIMING WAVEFORM OF WRITE CYCLE NO. 1 (\overline{WE} CONTROLLED) (1, 2, 3, 7)

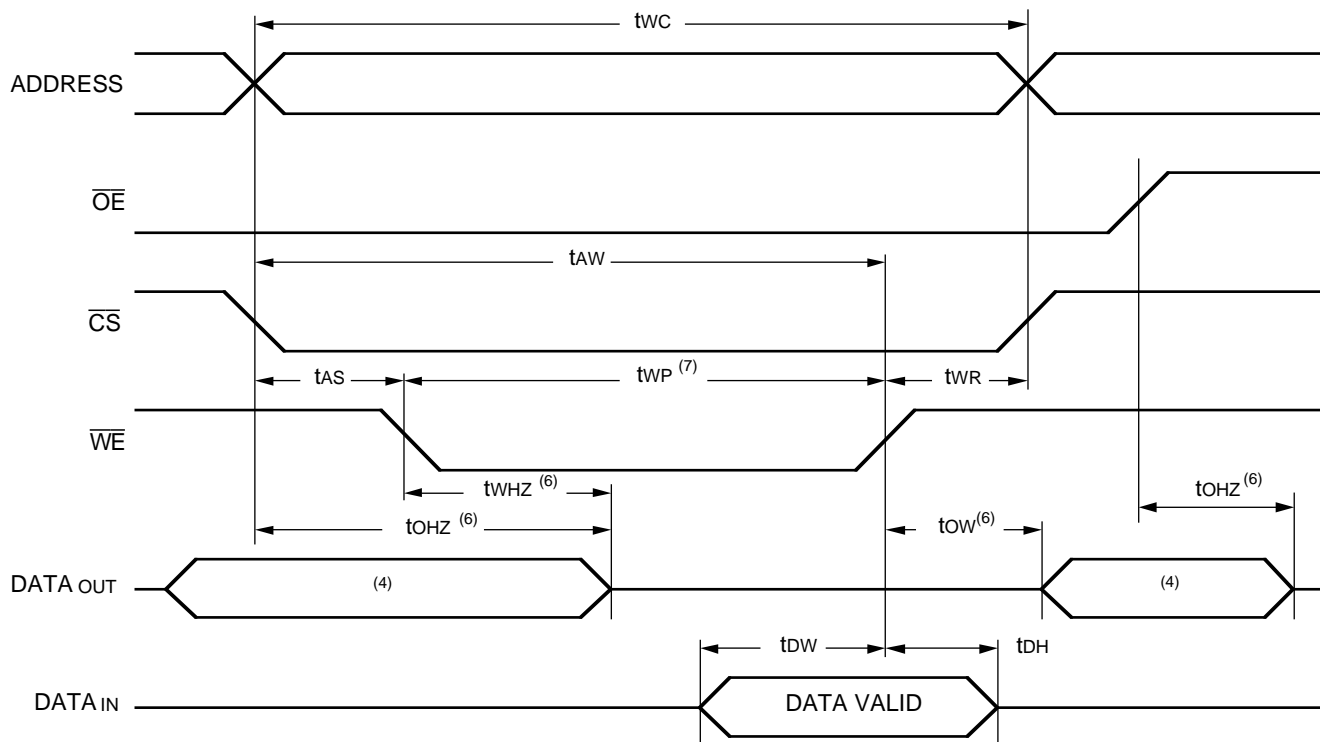

2703 drw 10

TIMING WAVEFORM OF WRITE CYCLE NO. 2 (\overline{CS} CONTROLLED) (1, 2, 3, 5)

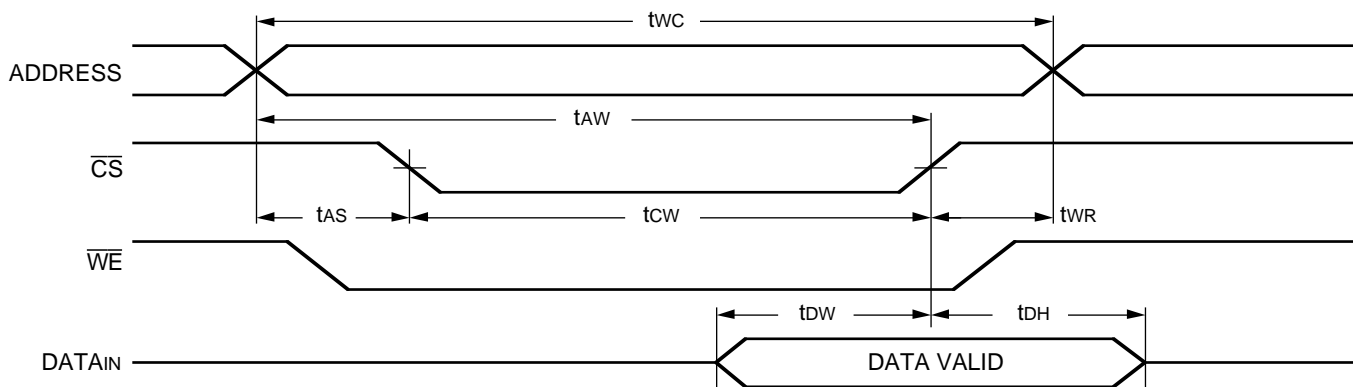

2703 drw 11

NOTES:

1. \overline{WE} or \overline{CS} must be HIGH during all address transitions.
2. A write occurs during the overlap (t_{WP}) of a LOW \overline{CS} and a LOW \overline{WE} .
3. t_{WR} is measured from the earlier of \overline{CS} or \overline{WE} going HIGH to the end of write cycle.
4. During this period, I/O pins are in the output state, and input signals must not be applied.
5. If the \overline{CS} LOW transition occurs simultaneously with or after the \overline{WE} LOW transition, the outputs remain in a high-impedance state.
6. Transition is measured $\pm 200\text{mV}$ from steady state with a 5pF load (including scope and jig). This parameter is guaranteed by design, but not tested.
7. If \overline{OE} is LOW during a \overline{WE} controlled write cycle, the write pulse width must be the larger of t_{WP} or $(t_{WHZ} + t_{DW})$ to allow the I/O drivers to turn off and data to be placed on the bus for the required t_{DW} . If \overline{OE} is HIGH during a \overline{WE} controlled write cycle, this requirement does not apply and the write pulse can be as short as the specified t_{WP} .

PACKAGE DIMENSIONS

7MP4045 ZIP VERSION

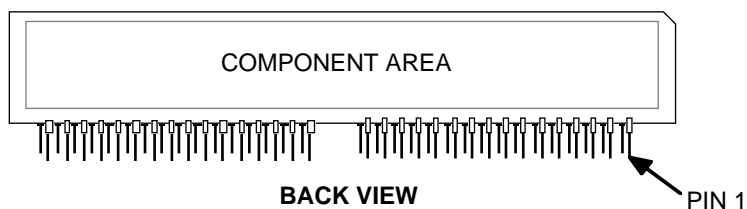
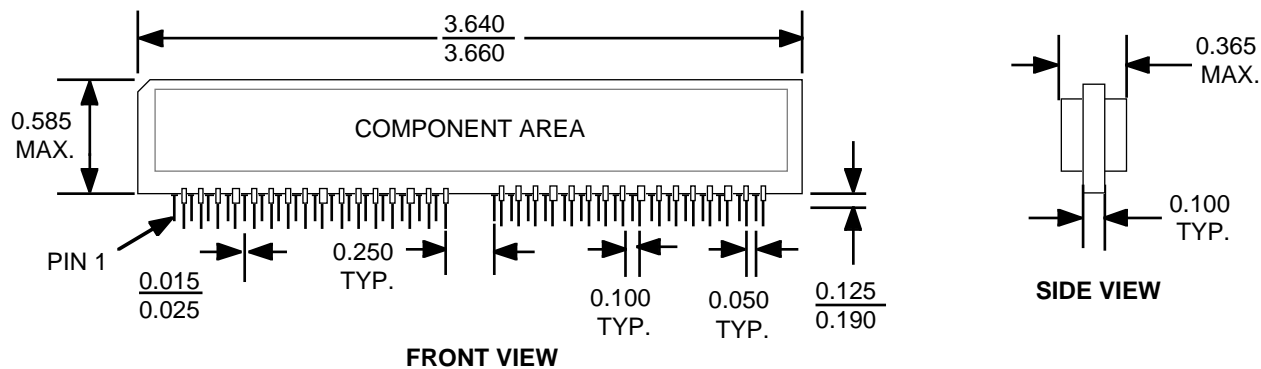

7MP4045 SIMM VERSION

2703 drw 12

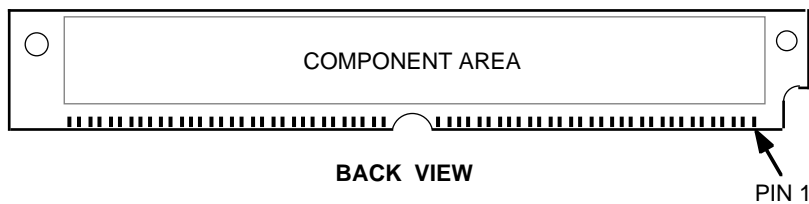
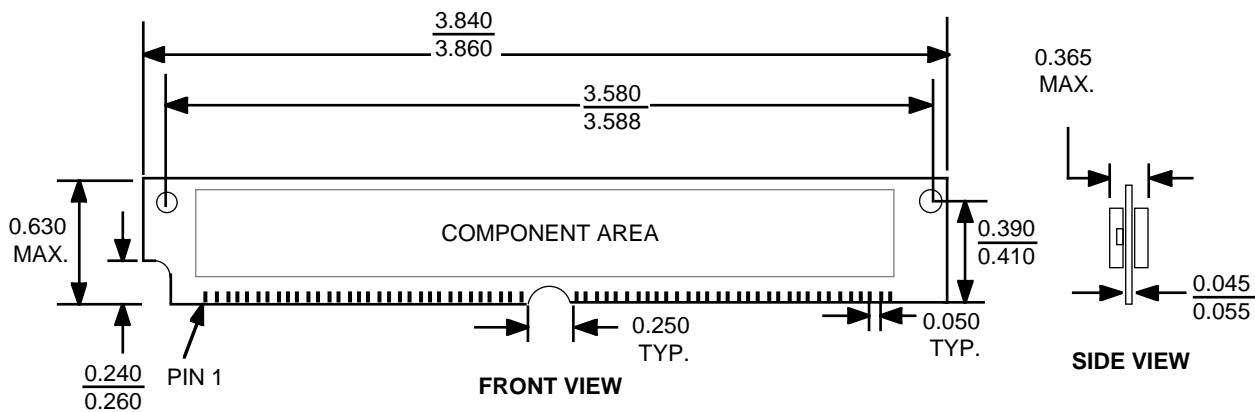

2703 drw 13

7MP4145 SIMM VERSION

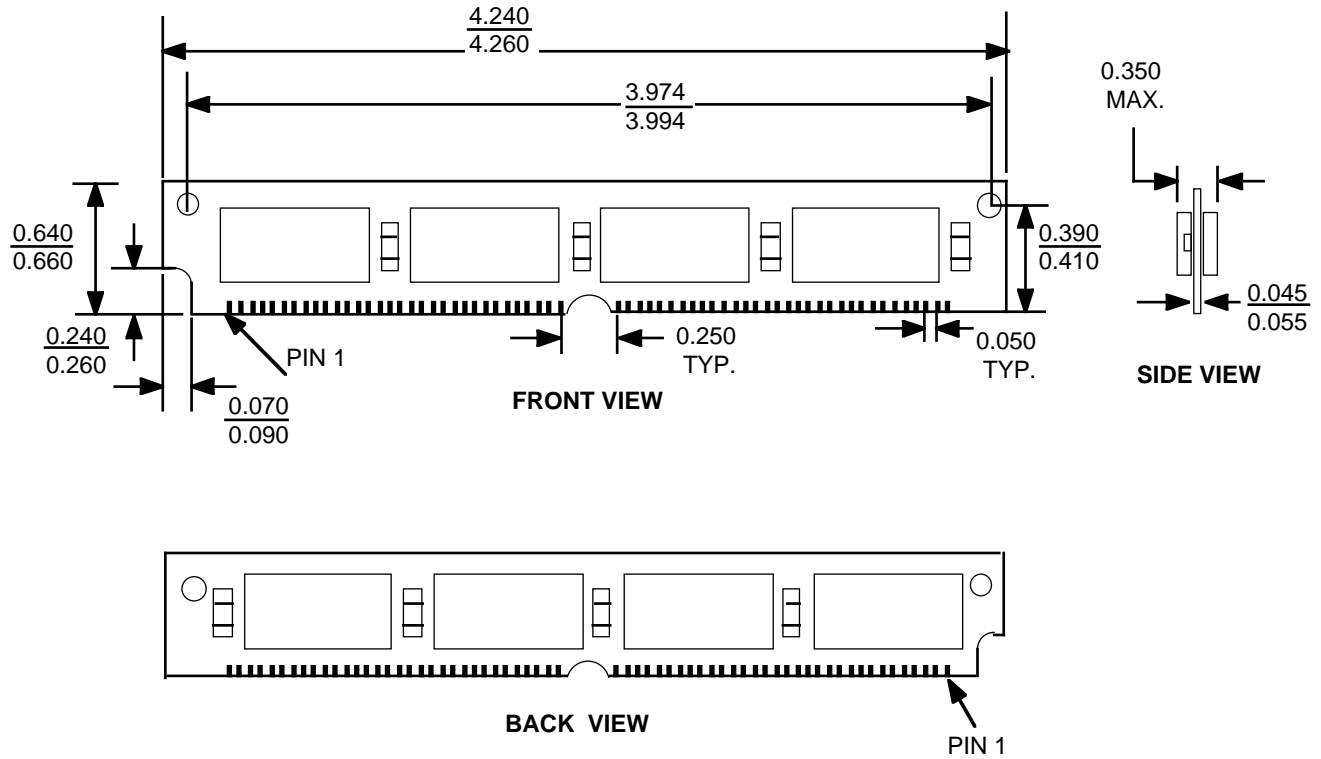

2703 drw 16

ORDERING INFORMATION

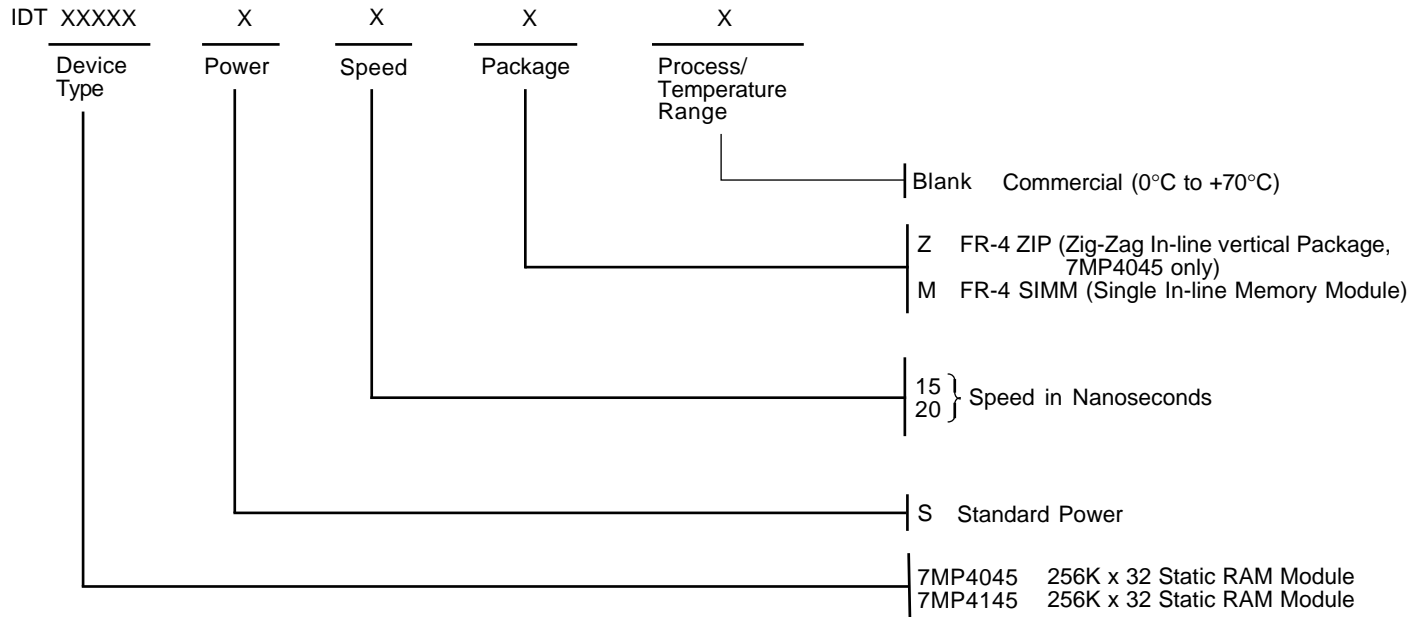

2703 drw 14