

MOTOROLA
SEMICONDUCTOR
TECHNICAL DATA

NONINVERTING
QUAD THREE-STATE BUS TRANSCEIVER

This quad three-state bus transceiver features both excellent MOS or MPU compatibility, due to its high impedance PNP transistor input, and high-speed operation made possible by the use of Schottky diode clamping. Both the -48 mA driver and -20 mA receiver outputs are short circuit protected and employ three-state enabling inputs.

The device is useful as a bus extender in systems employing the M6800 family or other comparable MPU devices. The maximum input current of 200 μ A at any of the device input pins assures proper operation despite the limited drive capability of the MPU chip. The inputs are also protected with Schottky-barrier diode clamps to suppress excessive undershoot voltages.

Propagation delay times for the driver portion are 17 ns maximum while the receiver portion runs 17 ns. The MC8T28 is identical to the NE8T28 and it operates from a single +5 V supply.

- High Impedance Inputs
- Single Power Supply
- High Speed Schottky Technology
- Three-State Drivers and Receivers
- Compatible with M6800 Family Microprocessor
- Non-Inverting

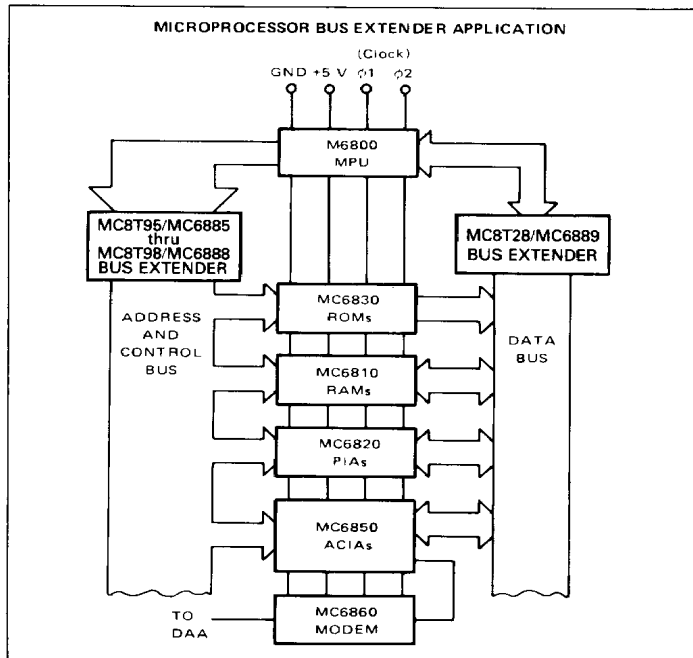

MC8T28
(MC6889)

NONINVERTING
BUS TRANSCEIVER

MONOLITHIC SCHOTTKY
INTEGRATED CIRCUITS



L SUFFIX
CERAMIC PACKAGE
CASE 620

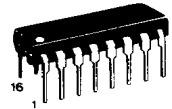

P SUFFIX
PLASTIC PACKAGE
CASE 648

PIN CONNECTIONS — MC8T28
(MC6889)

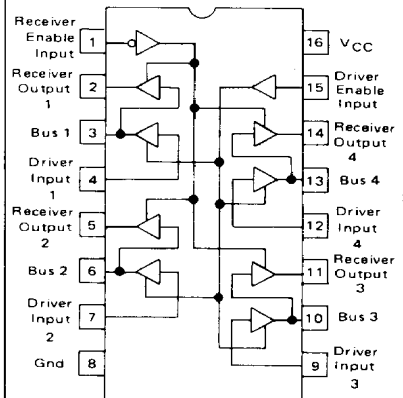

ORDERING INFORMATION

Device	Alternate	Temperature Range	Package
MC8T28L	MC6889L	0 to -75 °C	Ceramic DIP
MC8T28P	MC6889P		Plastic DIP

MC8T28

MAXIMUM RATINGS (T_A = 25°C unless otherwise noted.)

Rating	Symbol	Value	Unit
Power Supply Voltage	V _{CC}	8.0	V _{dc}
Input Voltage	V _I	5.5	V _{dc}
Junction Temperature	T _J		°C
Ceramic Package		175	
Plastic Package		150	
Operating Ambient Temperature Range	T _A	0 to +75	°C
Storage Temperature Range	T _{stg}	-65 to +150	°C

ELECTRICAL CHARACTERISTICS (4.75 V < V_{CC} < 5.25 V and 0°C < T_A < 75°C unless otherwise noted.)

Characteristic	Symbol	Min	Typ	Max	Unit
Input Current – Low Logic State (Receiver Enable Input, V _{IL(RE)} = 0.4 V) (Driver Enable Input, V _{IL(DE)} = 0.4 V) (Driver Input, V _{IL(D)} = 0.4 V) (Bus (Receiver) Input, V _{IL(B)} = 0.4 V)	I _{IL(RE)} I _{IL(DE)} I _{IL(D)} I _{IL(B)}	--	--	-200	μA
Input Disabled Current – Low Logic State (Driver Input, V _{IL(D)} = 0.4 V)	I _{IL(D) DIS}	--	--	-25	μA
Input Current-High Logic State (Receiver Enable Input, V _{IH(RE)} = 5.25 V) (Driver Enable Input, V _{IH(DE)} = 5.25 V) (Driver Input, V _{IH(D)} = 5.25 V)	I _{IH(RE)} I _{IH(DE)} I _{IH(D)}	--	--	25	μA
Input Voltage – Low Logic State (Receiver Enable Input) (Driver Enable Input) (Driver Input) (Receiver Input)	V _{IL(RE)} V _{IL(DE)} V _{IL(D)} V _{IL(B)}	--	--	0.85	V
Input Voltage – High Logic State (Receiver Enable Input) (Driver Enable Input) (Driver Input) (Receiver Input)	V _{IH(RE)} V _{IH(DE)} V _{IH(D)} V _{IH(B)}	2.0	--	--	V
Output Voltage – Low Logic State (Bus Driver) Output, I _{OL(B)} = 48 mA) (Receiver Output, I _{OL(R)} = 20 mA)	V _{OL(B)} V _{OL(R)}	--	--	0.5	V
Output Voltage – High Logic State (Bus (Driver) Output, I _{OH(B)} = -10 mA) (Receiver Output, I _{OH(R)} = -2.0 mA) (Receiver Output, I _{OH(R)} = -100 μA, V _{CC} = 5.0 V)	V _{OH(B)} V _{OH(R)}	2.4	3.1	--	V
Output Disabled Leakage Current – High Logic State (Bus Driver) Output, V _{OH(B)} = 2.4 V) (Receiver Output, V _{OH(R)} = 2.4 V)	I _{OHL(B)} I _{OHL(R)}	--	--	100	μA
Output Disabled Leakage Current – Low Logic State (Bus Output, V _{OL(B)} = 0.5 V) (Receiver Output, V _{OL(R)} = 0.5 V)	I _{OLL(B)} I _{OLL(R)}	--	--	-100	μA
Input Clamp Voltage (Driver Enable Input I _{ID(DE)} = -12 mA) (Receiver Enable Input I _{IC(RE)} = +12 mA) (Driver Input I _{IC(D)} = -12 mA)	V _{IC(DE)} V _{IC(RE)} V _{IC(D)}	--	--	-1.0	V
Output Short Circuit Current, V _{CC} = 5.25 V, Note 1 (Bus (Driver) Output) (Receiver Output)	I _{OS(B)} I _{OS(R)}	-50	--	-150	mA
Power Supply Current (V _{CC} = 5.25 V)	I _{CC}	--	--	110	mA

Note 1. Only one output may be short-circuited at a time.

MC8T28

SWITCHING CHARACTERISTICS (Unless otherwise noted, $V_{CC} = 5.0\text{ V}$ and $T_A = 25^\circ\text{C}$)

Characteristic	Symbol	Min	Max	Unit
Propagation Delay Time--Receiver ($C_L = 30\text{ pF}$)	$t_{PLH(R)}$	—	17	ns
	$t_{PHL(R)}$	—	17	ns
Propagation Delay Time--Driver ($C_L = 300\text{ pF}$)	$t_{PLH(D)}$	—	17	ns
	$t_{PHL(D)}$	—	17	ns
Propagation Delay Time--Enable ($C_L = 30\text{ pF}$)	— Receiver	—	23	ns
	$t_{PZL(R)}$	—	18	ns
	— Driver Enable ($C_L 300\text{ pF}$)	—	28	ns
	$t_{PZL(D)}$	—	23	ns

FIGURE 1 – TEST CIRCUIT AND WAVEFORMS FOR PROPAGATION DELAY FROM BUS (RECEIVER) INPUT TO RECEIVER OUTPUT, $t_{PLH(R)}$ AND $t_{PHL(R)}$

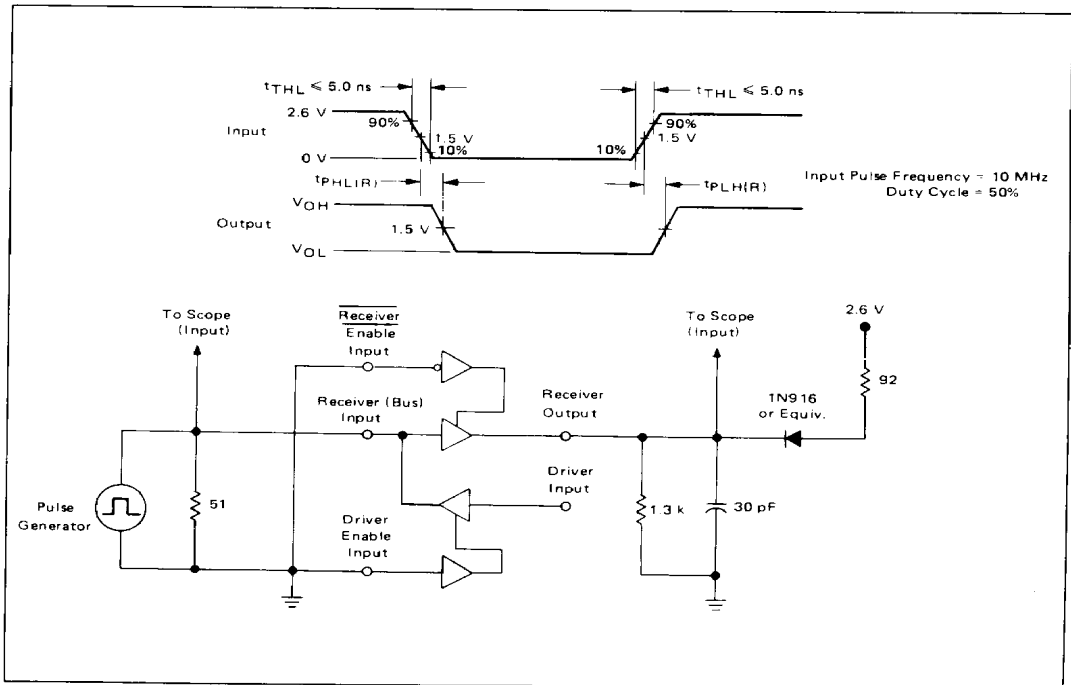

MC8T28

FIGURE 2 – TEST CIRCUIT AND WAVEFORMS FOR PROPAGATION DELAY TIME FROM DRIVER INPUT TO BUS (DRIVER) OUTPUT, $t_{PLH(D)}$ AND $t_{PLH(D)}$

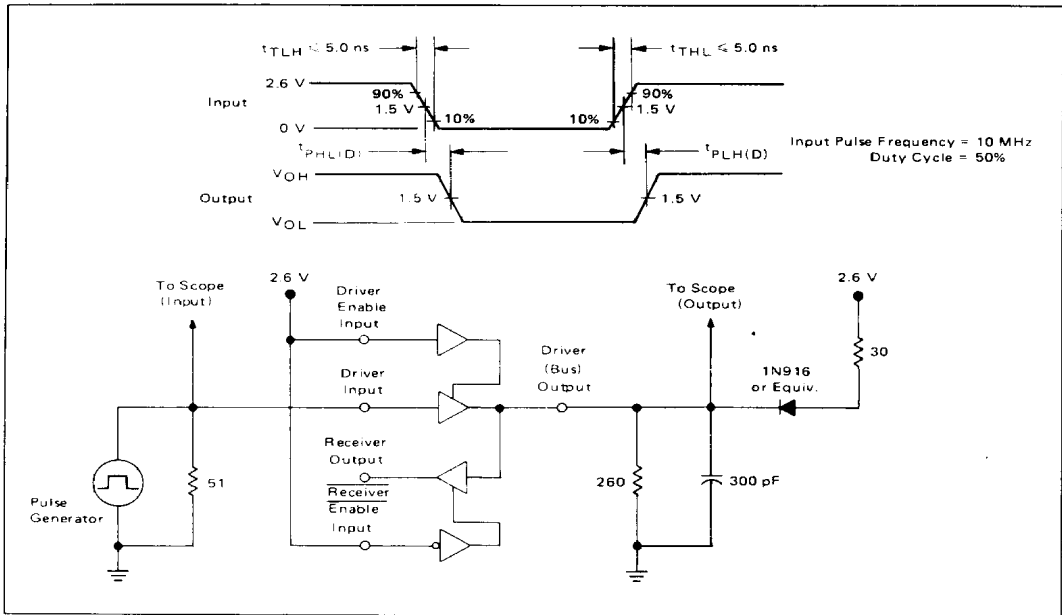
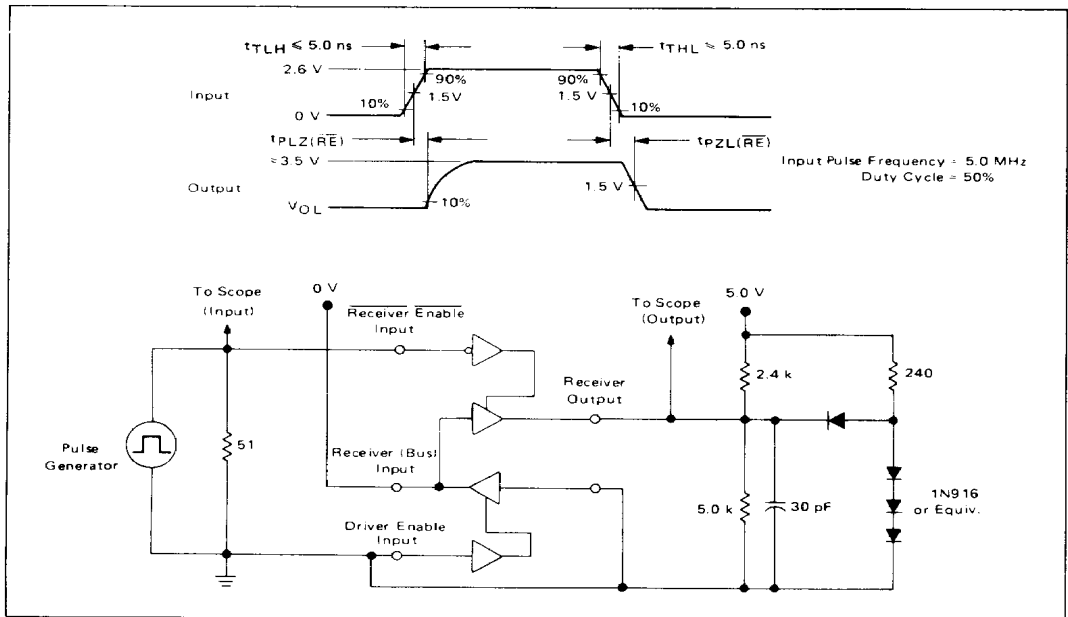

FIGURE 3 – TEST CIRCUIT AND WAVEFORMS FOR PROPAGATION DELAY TIME FROM RECEIVER ENABLE INPUT TO RECEIVER OUTPUT, $t_{PLZ(RE)}$ AND $t_{PZL(RE)}$



MC8T28

FIGURE 4 – TEST CIRCUIT AND WAVEFORMS FOR PROPAGATION DELAY TIMES FROM DRIVER ENABLE INPUT TO DRIVER (BUS) OUTPUT, $t_{PLZ}(DE)$ AND $t_{PZL}(DE)$

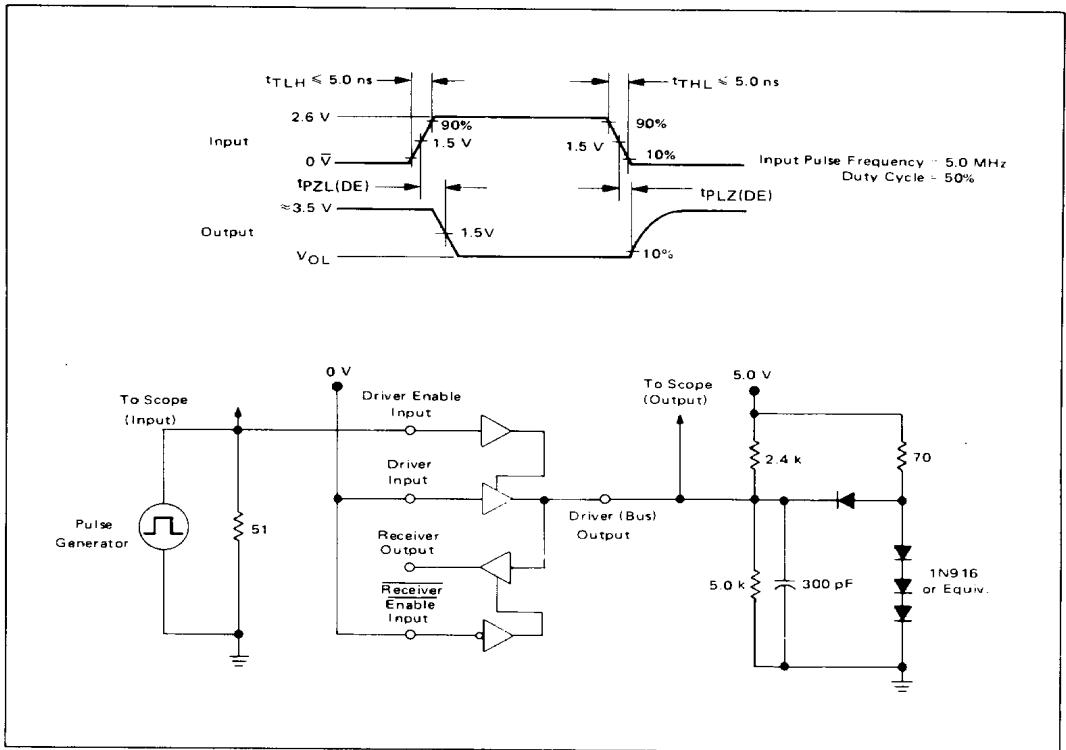

FIGURE 5 – BIDIRECTIONAL BUS APPLICATIONS

